

# Vehicle Health Monitoring Concepts and Safety Techniques

A thesis report submitted to the Department of Mechanical Engineering, Sonargaon University (SU), in partial fulfillment of the requirements for the degree of “**Bachelor of Science in Mechanical Engineering**”.

## **SUPERVISED BY**

**Nusrat Sharmin**  
Lecturer  
Mechanical Engineering  
Sonargaon University (SU)

## **SUBMITTED BY**

**Tonmoy Das**  
ID: BME 1602009066  
**Md. Abul Kalam**  
ID: BME 1602009067  
**Md. Rayhan Siddiqy**  
ID: BME 1602009068  
**Muhammad Abdur Rahim**  
ID: BME 1602009069  
**Md. Harunor Rashid**  
ID: BME 1503007647



**Department of Mechanical Engineering**  
**Sonargaon University (SU)**

---

## Table of Contents

ACKNOWLEDGEMENT.....	5
ABSTRACT.....	6
ALL ABBREVIATION & MEANINGS.....	7
CHAPTER 1	
INTRODUCTION	
1.1 Introduction.....	8-9
1.2 Objective.....	10
CHAPTER 2	
LITERATURE REVIEW	
2.1 Background.....	11
2.2 Literature survey.....	11-12
2.3 Focus on Study.....	12-14
2.4 Load sensor.....	14-15
2.5 Bluetooth module.....	15
2.6 Vibration sensor.....	16
2.7 NodeMCU.....	17
2.8 Power supply.....	17-18
2.9 PCB board.....	18
2.10 Connecting wire.....	19
2.11 About Arduino.....	19-23
2.12 About thinkable.....	23-24
CHAPTER 3	
METHODOLOGY	
3.1 Introduction.....	25
3.2 Experimental setup.....	25-26
3.3 Block Diagram.....	26
3.4 Working Procedure.....	27-30
3.5 Procedure of Arduino board connection with computer.....	30
3.6 Arduino board coding.....	31-32
3.7 Apps development.....	33-34
3.8 Overview of Thinkable.....	35

CHAPTER 4	
RESULT & DISCUSSION	
4.1 Introduction.....	36-38
4.2 Project output photographic view.....	38
CHAPTER 5	
CONCLUSION	
5.1 Conclusion.....	39
REFERENCE	
1 Reference.....	40

## List of Figure Name

Figure 1 (Flow diagram of data monitoring concepts).....	8
Figure 2 (Load sensor visualization) .....	15
Figure 3 (Bluetooth module) .....	15
Figure 4 (Vibration Sensor).....	16
Figure 5 (NodeMcu visualization) .....	17
Figure 6 (Power Supply).....	18
Figure 7 (PCB Board) .....	18
Figure 8 (Connecting wires).....	19
Figure 9 (Arduino community) .....	19
Figure 10 (Arduino Nano).....	20
Figure 11 (Arduino Nano VS Arduino Uno) .....	23
Figure 12 (Block Diagram of this project).....	26
Figure 13 (Fuel Level Indicator system block diagram).....	27
Figure 14 (Load Sensor block diagram).....	28
Figure 15 (Brake pad worn-out indicator system block diagram).....	28
Figure 16 (Accidental identification system block diagram).....	29
Figure 17 (Bluetooth (GPS) tracking block diagram).....	30
Figure 18 (Arduino board connecting procedure).....	30
Figure 19 (Apps Development coding).....	33
Figure 20 (Apps Development dashboard).....	33
Figure 21 (Apps Developing code of all).....	34
Figure 22 (Live test in thinkable pannel).....	34
Figure 23 (Project overall view).....	36
Figure 24 (Apps output panel).....	38
Figure 25 (Project others view).....	38

## **ACKNOWLEDGEMENT**

The author wants to express gratefulness, regard, gratitude and sincere thanks to supervisor Nusrat Sharmin, Lecturer, Department of Mechanical Engineering, Sonargaon University (SU), for his guidance and valuable counsel in execution and completion of the study without which it would be impossible to carry out the work.

Also thanks to Md. Mostofa Hossain, Associate Professor and Head of the Department of Mechanical Engineering, Sonargaon University (SU), for giving this opportunities and permission to do this project.

Author grateful to the teachers who help us directly or indirectly which was very necessary to complete this project work.

Finally, we are also grateful to the vice-chancellor of Sonargaon University (SU), for his overall support to finish the project works.

“Author”

## **ABSTRACT**

This paper deals with the design and development of an IoT based embedded system for detecting the vehicle health condition & safety by monitoring various parameters of a vehicle based on some threshold value. In this project, an integrated system is being developed which is a proper blending of hardware (electronics) and the software to monitor fuel theft, identification of fuel consumption, brake shoe/pad worn out indication as well as load status of a vehicle and transmit it to a webserver to store that information along with a unique identification number, different parameters along with date and time. This helps in increasing the life span of the vehicle as well as the engine. It also helps in abiding sudden multifunctioning of the vehicle when may result in any kind of accident. Ended up, the owner will be notified the all parameter's simulated data through mobile application according to the present condition of his vehicle.

## ➤ All Abbreviation & Meanings

In this project, we have used some shortcut keyword. For that reason, all the abbreviation are given below.

1. **IoT Based** – Internet of Things based
2. **PHP** – Personal Home Page
3. **HTML** – Hypertext Markup Language
4. **MySQL**- My Structured Query Language (It is an Open-source relational data-based system.
5. **WAMP** – Windows, Apache, MySQL and PHP (It is a variation of LAMP for windows)
6. **PC**- Personal Computer.
7. **OBD**- On-Board Diagnosis port
8. **OBD II** – On-Board Diagnosis 2 port
9. **EPA** – Environmental Protection Agency
10. **SAE** – Society of Automotive Engineers
11. **VEDAS** – Valcom Environmental Acquisition System. (It is a mobile data stream mining environment)
12. **Minefleet**- It is also a mobile data stream mining environment.
13. **PCA** – Principal Component Analysis.
14. **SAWUR**–Situation Awareness With Ubiquitous data mining for Road safety.
15. **NodeMCU** – Open source electronics Platform.
16. **LED** – Light Emitting Diode.
17. **PCB** – Printed Circuit Board.
18. **Arduino** – It's an open-source electronic Platform.
19. **USB** – Universal Serial Bus.
20. **iOS**- internetwork Operating System.
21. **Thunkable** – Easiest way to build up apps
22. **APK** – Android Application Package
23. **LCD**- Liquid Crystal Display
24. **GPS** – Global Positioning System
25. **Buzzer** – An electrical device that makes a buzzing noise & used for signalling.
26. **PVC Board** – Polyvinyl Chloride board.

# CHAPTER 1

## INTRODUCTION

### 1.1 Introduction

In this busy world, everyone uses vehicles for transportation but due to busy schedule, people cannot spare time for its proper maintenance. Many people periodically visit the service centre for servicing and maintenance of the vehicle but many people are not concerned about this issue due to many constraints, it may be lack of time or work overload etc. If the manufacturing company (service provider) can monitor the health of the vehicle remotely, it would be a beneficial service for both the owners of the vehicle as well as the concerned company.

Along with the up-gradation of technology we need to develop the service providing process to solve the proper maintenance of vehicle so that owners can save their time and take aim to their regular works. If we can develop the relationship between mechanical and electronics, the owner gets proper information before happening any phenomena of his vehicle around the systems.

According to relation, we have developed a system with IoT based where hardware part consists of microprocessor which is responsible for collecting and processing data based on various parameters from the vehicle using sensors and send to the server over a unique IP address whereas the software part which consists of a web application, is responsible for receiving the data and store it in the database which can be retrieved later to create reports of the vehicle for any kind of requirements. As well as where web application uses PHP, HTML, and MySQL for receiving and storing the data. WAMP server is used to create a dummy server for hosting the application. The health & safety report can be accessed from a centralized location and by multiuser environment using PC, mobile phone, etc.

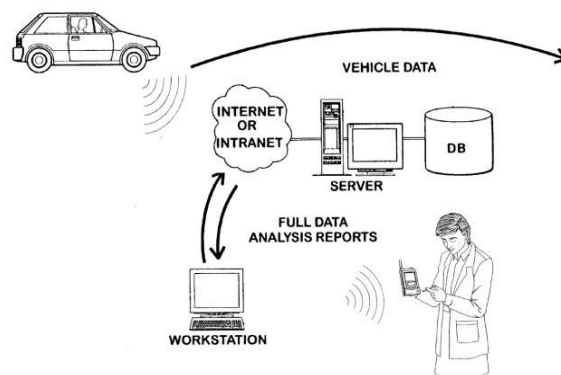

**Figure 1:** Flow diagram of data monitoring concepts



With the increase in a number of cars along with other modes of transport such as public transport system, vehicles for supply chains and two-wheelers on road, the issues like safety, fuel consumption is of utmost importance which depends on vehicle condition, road infrastructure and driver behaviour.

This project aims at developing an embedded system for detecting the vehicle condition by monitoring the internal parameters that are used in evaluating the vehicle's current health condition. These parameters are obtained using the OBD2 protocol through a port provided by the manufacturers to the vehicles.

A real-time evaluation system is being defined that can be used for rapid condition screening and provide reliable information about the vehicle conditions. This real-time evaluation system can be called the Vehicle Health Monitoring System.

This system uses HMI display so that the reports and the alerts can be displayed on it and also feedback from the user can be taken using its touch response.

The system model being developed is a standalone onboard model which will be a black box for the outside world. This model can be extended to identify and report the faults in a car to the authorized service centre through wireless communication, a concept of remote diagnostics.

Since 1996, OBD systems have been incorporated into vehicles to help manufacturers meet emission standards set forth by the Clean Air Act in 1990 and the Environmental Protection Agency (EPA). The Society of Automotive Engineers (SAE) developed a set of standards and practices that regulated the development of these diagnostic systems. The SAE expanded on that set to create the OBD-II standards. The OBD-II system allows for the monitoring of most electrical systems on the vehicle. The OBD- II standard specifies the type of diagnostic connector and its pinout, the electrical signalling protocols available, and the messaging format. It also provides a candidate list of vehicle parameters to monitor along with how to encode the data for each. As a result of this standardization, a single device can query the on-board computer(s) in any vehicle.

## 1.2 Objectives

- To notify the owner about the current situation of the vehicle.
- To notify the owner when the vehicle falls in any kind of major accident.
- To calculate specific fuel consumption & fuel tank volume (in litres) that the owner will know as his needed.
- To Control the vehicle fuel theft.
- To notify the owner how the amount of brake shoe/ pad has been worn out.
- To notify the cargo owner how the amount of weight is loaded by the driver.

# CHAPTER 2

## LITERATURE REVIEW

### 2.1 Background

'Vehicle health monitoring concepts and safety techniques' utilizes the sensor data on the vehicle, mine the data and predicts the health along with the safety condition of the vehicle. It provides an idea when the vehicle would be needed maintenance. The model also can warn when the vehicle becomes overloaded, consumed fuel into a specific level, brake shoe/pad became worn out intense and in case of a major accident occurs. The purpose of this research paper is to provide an overview of the existing 'Vehicle health monitoring concepts and safety techniques'. It discusses the different ways in which Vehicle Health can be monitored. It can be distributed or onboard data mining. Computation or mining in the vehicle are restricted by less memory and processor capacity, onboard mining is more advantageous than a fully distributed data mining system. This paper survey the existing model for computationally efficient Onboard Vehicle Health monitoring system.

A vehicle comes with 60-100 sensors which help in their effective monitoring. Digital electronic systems make it easy to constantly monitor vital engine parameters like oil pressure, coolant temperature and exhaust emissions etc. And report back to the driver when something is amiss. When the sensor data is monitored and mining is performed it would be possible to predict the good health or bad health of a vehicle.

The certain organization has a huge fleet of trucks. Regular maintenance of vehicles in such a fleet is an important part of supply chain management. There are also many fleet management companies which allow companies which rely on transportation in business to remove or minimize the risks associated with vehicle investment, improving efficiency, productivity. For this purpose, these companies collect the performance data, study the data offline and send the vehicles to service if necessary.

### 2.2 Literature survey

Many of the existing fleet management systems use one of the two approaches: One of them is discussed in. The sensor data from the vehicle is retrieved using a control module and the parameters are uploaded to the fleet database. In the fleet database, this data is analyzed and the performance parameters of a vehicle to be diagnosed is analyzed with the normal operation

of the corresponding parameters to determine whether the vehicle to be diagnosed operates outside or whether it is a normal operation. The disadvantage of this approach bandwidth available is limited; it is not possible or efficient to transmit the performance parameters to the fleet database.

Another approach is VEDAS; which works on the concept of Ubiquitous Data Mining. It is a mobile data stream mining environment. VEDAS analyses the data produced by the various sensors on the vehicle. It continuously monitors data stream generated by a moving vehicle using an onboard computing device, identifies emerging pattern and report these patterns to central control server using a low wireless network connection if necessary.

## **2.3 Focus on Study**

The devices that perform analysis on vehicles are PDA. The data mining task is usually to compute intensely. The ways to minimize the computation should be major criteria, because of the limited processor available for our system.

In order to arrive at the best strategy for this problem, it is necessary to understand the techniques used to arrive at the solution. The onboard sensor collects all the data and performs partial data mining. The transfer of entire data to the site would occupy more bandwidth. It is designed to do principal component analysis, incremental Fourier transform and online linear segmentation

### **2.3.1 VEDAS**

The vehicle has the number of sensors. To summarize the technology used in VEDAS. Each sensor in the vehicle produces a data stream that is converted into a covariance matrix. Tridiagonalization is done through householder method and QL method to predict the eigenvectors. After this process, the clustering is performed to analyse the health pattern of vehicle monitoring. Incremental Kmeans algorithm is used for this purpose.

The control base station does the visualization of data, event-based control of the vehicle. VEDAS [1] suggests the use of PCA projected data and incremental cluster, create a cluster using computational geometry.

1) Data Projection: First Principle Component Analysis is done over the covariance matrix to reduce the dimensionality. First covariance matrix converted into a triangular form using Householder transformation and Eigen analysis performed using the QL algorithm with an implicit shift. For initial data, the above procedure is carried out. Later VEDAS uses a sliding

window to select a sample of data from the stream of sensor data. The covariance matrix is calculated for the sample data. The uncertainty or perturbation in the covariance matrix is found using Matrix Perturbation theory [5] using Frobenius norm. The procedure of PCA is done only when there is a change in Eigenvector as a change in Eigenvalue implies a change in spectral distribution. When a matrix is found with the change in spectral distribution, for the matrix Principle Component Analysis is created.

2) Clustering: The paper assumes that initially when the vehicle is certified as good health, then the behaviour of vehicle can be observed and the cluster becomes stable. When the observed data point falls outside the stable cluster, then the vehicle is in bad health. For this purpose, the paper suggests the use of incremental clustering. Further, the on-board memory is small and it would not be possible to store the entire dataset, instead of the cluster can be incremented. The cluster is created using Delaunay Triangulation based polygonization approach. When an outlier is detected in the then Gaussian distribution for the set of data samples are created. VEDAS makes use of various distribution algorithm to identify the behaviour of vehicles.

Memory and processor capacity is very important in this technology. The process which consumes the most of computation is for computing principal component analysis  $O(m^3, n^3)$  and the computation complexity of covariance matrix  $O(mn^2)$ . PCA is performed by using Householder transformation and QL algorithm with an implicit shift [5]. This Fast Principle Component Analysis which again has a complexity of  $O(mn^2)$ . Even though Principal Component Analysis is done only when there is a spectral disturbance, the Covariance matrix is done during a fixed interval [5]. This would be a burden on the processor. When the number sensor parameter increases, the computation complexity increases.

### **2.3.2 MINE FLEET**

Mine fleet also was written by the same author in 2006. On the vehicle, the memory capacity and also the processor capacity available is less. To enable the efficient working of this process it is necessary to implement a less power memory utilization algorithm. Correlation matrix provides the correlation between two features. The correlation matrix is calculated by normalizing the dataset. The result is a normalized matrix  $U$ .  $U^T.U$  provides the correlation matrix. [2]

In real life, not all the features are correlated, at most two or three variable are correlated with one another. So it is not necessary to compute the entire correlation matrix. Instead of this

research paper adopts divide and conquer strategy [8]. The subsets of data are checked to find whether they have a significant coefficient. Only for the subset of the data correlation coefficient is found in the large sparse matrix.

When compared to VEDAS the mine Fleet is more suitable for continuous low overhead monitoring.

### **A. Vehicle Failure Prediction Using Warranty and Telematics Data**

In 2011 Last, Mark analyses Vehicle Failure Prediction. Previous collected crash data from SAWUR (Situation-Awareness With Ubiquitous data mining for Road safety) database is used in this paper to arrive at the prediction model to minimize the risk of an unexpected failure. Further, when car undergoes maintenance it's periodic and based on the mileage of the car. Vehicle condition does not necessarily deteriorate with time and run. This paper also aims at providing conditional maintenance, i.e. maintenance when vehicle health is not good.[3]

### **B. On-board vehicle data mining, social networking, advertisement**

In 2013, the same author Kargupta published a patent, US 8478514 B2. This used the same technology as the mine Fleet but improved it with using Social networking. Same as the mine Fleet the On-board module is equipped with embedded devices, PDA to perform data stream mining. Analytics are generated from the vehicle are sent in predefined intervals to a server over the wireless network. The extensive analysis of data would be done in the control base and further on the webserver. The web server would provide targeted advertising for the performance graph to the vehicles. This paper improves the vehicle health monitoring system & some safety techniques by performing mining a server and advertising the analysis to the vehicles. [4]

## **2.4 Load Sensor**

A **load sensor** is a type of force transducer and another name is 'strain gauge'. It converts a force such as tension, compression, pressure, or torque into an electrical signal that can be measured and standardized. As the force applied to the load cell increases, the electrical signal changes proportionally.[8]

Besides a Strain gauge (sometimes referred to as a Strain gage) is a sensor whose resistance varies with applied force; It converts force, pressure, tension, weight, etc., into a change in electrical resistance which can then be measured. When external forces are applied to a

stationary object, stress and strain are the results. Stress is defined as the objects internal

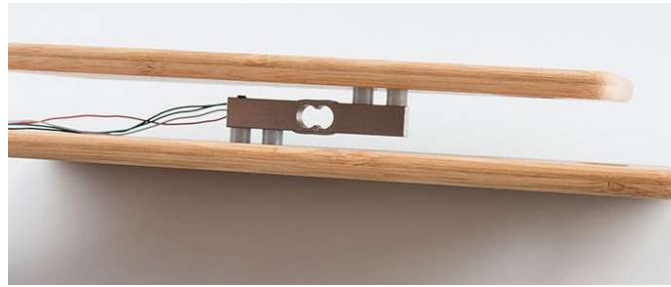

**Figure 2:** Load sensor visualization

Resisting forces and strain are defined as the displacement and deformation that occur. The strain gauge is one of the most important sensors of the electrical measurement technique applied to the measurement of mechanical quantities. As their name indicates, they are used for the measurement of strain. As a technical term "strain" consists of tensile and compressive strain, distinguished by a positive or negative sign. Thus, strain gauges can be used to pick up expansion as well as contraction. [8]

## 2.5 Bluetooth Module

Bluetooth technology is a high speed low powered wireless technology link that is designed to connect phones or other portable equipment together. It is a specification (IEEE 802.15.1) for the use of low power radio communications to link phones, computers and other network devices over a short distance without wires. Wireless signals transmitted with Bluetooth cover short distances, typically up to 30 feet (10 meters). It is achieved by embedded low

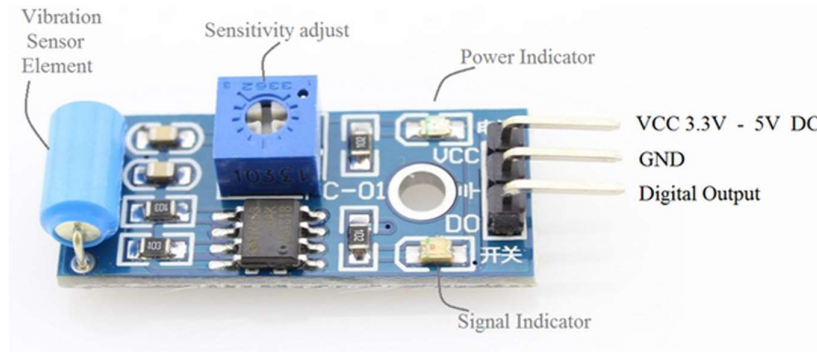

**Figure 3:** Bluetooth module

cost transceivers into the devices. It supports on the frequency band of 2.45GHz and can support up to 721KBps along with three voice channels. This frequency band has been set aside by international agreement for the use of industrial, scientific and medical devices (ISM).rd- compatible with 1.0 devices.[9]

## 2.6 Vibration Sensor

The vibration sensor is also called a piezoelectric sensor. These sensors are flexible devices which are used for measuring various processes. This sensor uses the piezoelectric effects while measuring the changes within acceleration, pressure, temperature and force otherwise strain by changing to an electrical charge. This sensor is also used for deciding fragrances within the air by immediately measuring capacitance as well as quality.



**Figure 4:** Vibration sensor

The working principle of vibration sensor is a sensor which operates based on different optical otherwise mechanical principle for detecting observed system vibrations. Vibration sensor module the sensitivity of these sensors normally range from 10 mV/g to 100 mV/g and there are lower and higher sensitivities are also accessible. The sensitivity of the sensor can be selected based on the application. So it is essential to know the levels of vibration amplitude range to which the sensor will be exposed throughout measurements.[10]

In this project, we have used this sensor for providing an actual accident report. We know, when a vehicle becomes towards any kind of accident, it must create high vibration whatever bash around it. According to the vibration intensity, the microcontroller takes a decision for output. If the vibration is crossed the safety limit, the microcontroller will be notified to the owner by mobile application along with starting danger alarm after an accidental moment.[10]



## 2.7 NodeMCU

NodeMCU refers to an open-source electronics platform or board and the software used to program it. NodeMCU is designed to make electronics more accessible to artists, designers, hobbyists and anyone interested in creating interactive objects or environments. NodeMCU is an open-source hardware and software company, project and user community that designs and



**Figure 5:** NodeMcu visualization

manufactures single-board microcontrollers and microcontroller kits for building digital devices. NodeMCU is an open-source electronics platform based on easy-to-use hardware and software. NodeMCU boards are able to read inputs - light on a sensor, a finger on a button, or a Twitter message - and turn it into an output - activating a motor, turning on an LED, publishing something online.

The NodeMCU board is connected to a computer via USB, where it connects with the Arduino development environment (IDE). The user writes the Arduino code in the IDE, then uploads it to the microcontroller which executes the code, interacting with inputs and outputs such as sensors, motors, and lights.[3]

## 2.8 Power Supply

A power supply is an electrical device that supplies electric power to an electrical load. The primary function of a power supply is to convert electric current from a source to the correct voltage, current, and frequency to power the load. Also called a power supply unit or PSU, the component that supplies power to a computer. Most personal computers can be plugged into standard electrical outlets. The power supply then pulls the required amount of electricity and converts the AC current to DC current. One purpose of a power supply is to convert AC to DC so the computer has proper power to run its components. Another purpose of a power supply is

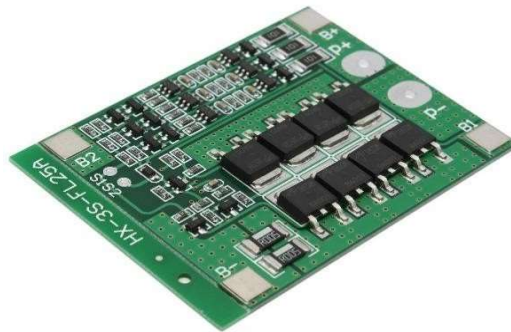

**Figure 6:** Power Supply

to distribute proper DC voltage to each component. Several cables with connectors come out of the power supply.[4]

## 2.9 PCB Board

A printed circuit board mechanically supports and electrically connects electronic components or electrical components using conductive tracks, pads and other features etched from one or more sheet layers of copper laminated onto or between sheet layers of a non-conductive substrate. PCB is an acronym for the printed circuit board. It is a board that has lines and pads that

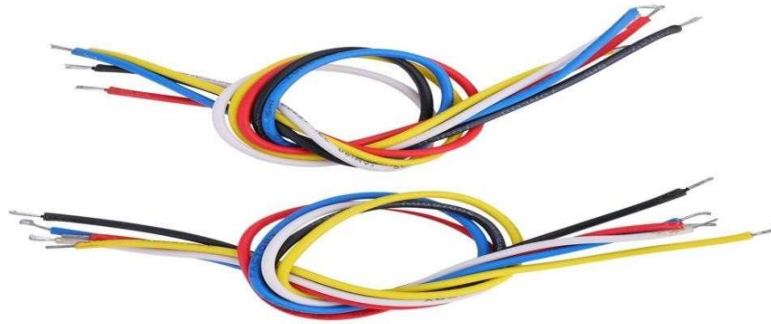

**Figure 7:** PCB Board

connect various points together. A PCB allows signals and power to be routed between physical devices. Solder is the metal that makes the electrical connections between the surface of the PCB and the electronic components. The substrate most commonly used in printed circuit boards is a glass fibre reinforced (fibreglass) epoxy resin with a copper foil bonded on to one or both sides. PCB made from paper reinforced phenolic resin with a bonded copper foil are less expensive and are often used in household electrical devices. [7]

## 2.10 Connecting wire

Connecting wires allows an electrical current to travel from one point on a circuit to another because electricity needs a medium through which it can move. Most of the connecting wires are made up of copper or aluminium. The wires in a circuit carry the electric current to various parts of an electrical or electronic system. Two wires connect to the light. For electrons to do their job in producing light, there must be a complete circuit so they can flow through the light bulb and then back out.[4]



**Figure 8:** Connecting wires

## 2.11 Arduino

Arduino is an open-source electronics platform based on easy-to-use hardware and software. Arduino boards are able to read inputs - light on a sensor, a finger on a button, or a Twitter message - and turn it into an output - activating a motor, turning on an LED, publishing something online. Arduino consists of both a physical programmable circuit board (often referred to as a microcontroller) and



**Figure 9:** Arduino community

a piece of software, or IDE (Integrated Development Environment) that runs on your computer, used to write and upload computer code to the physical board. In fact, you already are; the Arduino language is merely a set of C/C++ functions that can be called from your code. Your sketch undergoes minor changes (e.g. automatic generation of function prototypes) and then is passed directly to a C/C++ compiler.[2]

## 2.12 Arduino Nano

One of the most popular Arduino boards out there is the Arduino Uno. While it was not actually the first board to be released, it remains to be the most actively used and most widely documented on the market. Because of its extreme popularity, the Arduino Uno has a ton of project tutorials and forums around the web that can help you get started or out of a jam. We're big fans of the Uno because of its great features and ease of use.

Here are the components that make up an Arduino board and what each of their functions is.[2]

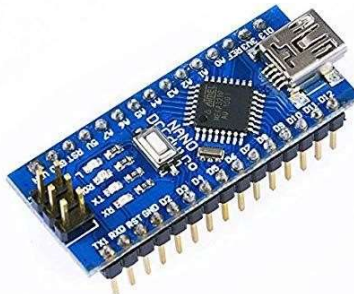

**Figure 10:** Arduino Nano

### 2.12.1 Pinout of Arduino Nano

- Reset Button – This will restart any code that is loaded to the Arduino board.
- AREF – Stands for “Analog Reference” and is used to set an external reference voltage.
- Ground Pin – There are a few ground pins on the Arduino and they all work the same.
- Digital Input/Output – Pins 0-13 can be used for digital input or output.
- PWM – The pins marked with the (~) symbol can simulate analogue output.
- USB Connection – Used for powering up your Arduino and uploading sketches.
- TX/RX – Transmit and receive data indication LEDs.
- ATmega Microcontroller – This is the brains and is where the programs are stored.

- Power LED Indicator – This LED lights up anytime the board is plugged in a power source.
- Voltage Regulator – This controls the amount of voltage going into the Arduino board.
- DC Power Barrel Jack – This is used for powering your Arduino with a power supply.
- 3.3V Pin – This pin supplies 3.3 volts of power to your projects.
- 5V Pin – This pin supplies 5 volts of power to your projects.
- Ground Pins – There are a few ground pins on the Arduino and they all work the same.
- Analog Pins – These pins can read the signal from an analogue sensor and convert it to digital.

## 2.13 Programing on Arduino



Once the circuit has been created on the breadboard, you'll need to upload the program (known as a sketch) to the Arduino. The sketch is a set of instructions that tells the board what functions it needs to perform. An Arduino board can only hold and perform one sketch at a time. The software used to create Arduino sketches is called the IDE which stands for Integrated Development Environment. The software is free to download and can be found at <https://www.arduino.cc/en/Main/Software>

Once the software has been installed on your computer, go ahead and open it up. This is the Arduino IDE and is the place where all the programming will happen.

Take some time to look around and get comfortable with it.

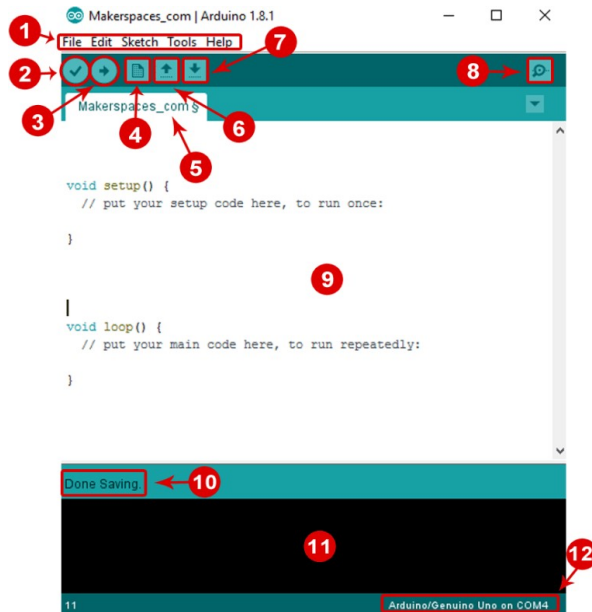

**Figure:** Arduino Programming panel

1. **Menu Bar:** It has been given access to the tools needed for creating and saving Arduino sketches.
2. **Verify Button:** It can be done compiles code and checks for errors in spelling or syntax.
3. **Upload Button:** Sends the code to the board that's connected such as Arduino Uno in this case. Lights on the board will blink rapidly when uploading.
4. **New Sketch:** Opens up a new window containing a blank sketch.
5. **Sketch Name:** When the sketch is saved, the name of the sketch is displayed here.
6. **Open Existing Sketch:** Allows the user to open a saved sketch or one from the stored examples.
7. **Save Sketch:** This saves the sketch it currently has open.
8. **Serial Monitor:** When the board is connected, this will display the serial information of Arduino.
9. **Code Area:** This area is where the code of the sketch has been composed that tells the board what to do.
10. **Message Area:** This area tells the status of saving, code compiling, errors and more.
11. **Text Console:** Shows the details of an error message, size of the program that was compiled and additional info.
12. **Board and Serial Port:** Tells what board is being used and what serial port it's connected.

## 2.14 Arduino Nano is better than Arduino Uno



**Figure 11:** Arduino Uno vs Arduino Nano

Arduino UNO is one of the most famous board in Arduino family after Arduino Duemilanove. It is the latest design of the basic USB board. It comes with 6 analogue inputs, 14 digitals output were 6 of them support PWM and 16Mhz clock speed. Arduino UNO comes with 6 analogue inputs and 14 digital I/O where 6 of them are PWM outputs. It is running on an ATmega328 processor with 32kB flash memory. The clock speed of this Arduino board is 16Mhz with the dimension of 68.6mm x 53.3mm. There are a lot of shields build to expend its functionality. Arduino Nano, As its name, Arduino Nano is a compact and breadboard-friendly version board based on ATmega328 processor. It is the more or less same functionality as the Arduino UNO but in a different package. Instead of using the standard USB to connect to the computer, it uses the mini USB but without the power plug for an external power source built on Arduino UNO. The dimension of Arduino Nano is only 43mm x 18mm, it comes with 6 PWM I/O from the total of 14 digitals I/O, 8 analogue inputs, 16Mhz clock speed and 32kB of flash memory. [4]

## 2.15 What is Thinkable?

Thinkable is the easiest way to build an app.

At Thinkable, our mission is simple -- to enable everyone to build their own beautiful and powerful mobile apps.

Instead of writing code, simply add your favourite components and connect them together. Instead of choosing between iOS or Android, Thinkable app projects work on both iOS and Android devices.[4]



### 2.15.1 Common 5 Steps to get a customized android app

- **Step 1(IDEA):** Start with a problem wanted to solve. Or be inspired by problems that other people have solved with apps.
- **Step 2(Create):** Add favourite technologies and write the story of how it is continued like them to work together with blocks.
- **Step 3(Test Live):** Download the Thunkable Live companion and test your apps while building them in real-time. Even hardcore developers don't have this.
- **Step 4(Publish):** For apps that wanted to reach greater audiences, follow the steps to publish, promote and maintain them on the Play Store. \$29 one-time fee required.
- **Step 5(IShare):** Sharing the app with friends and app source code with the larger Thinker community. The more sharing, the more problems that can be solved.



# CHAPTER 3

## METHODOLOGY

### 3.1 Introduction

The methodology is the general research strategy that outlines the way in which research is to be undertaken and among other things, identifies the methods to be used in it. These methods, described in the methodology. The methodology does not define specific methods, even though much attention is given to the nature and kinds of processes to be followed in a particular procedure or to attain an objective.

When proper to a study of methodology, such processes constitute a constructive generic framework. Therefore, be broken down into sub-processes, combined, or their sequence changed.

A paradigm is similar to a methodology in that it is also a constructive framework. In theoretical work, the development of paradigms satisfies most or all of the criteria for methodology. An algorithm, like a paradigm, is also a type of constructive framework, meaning that the construction is a logical, rather than a physical, array of connected elements.

Any description of a means of calculation of a specific result is always a description of a method and never a description of a methodology. It is thus important to avoid using methodology as a synonym for method or body of methods. Doing this shifts it away from its true epistemological meaning and reduces it to being the procedure itself, or the set of tools, or the instruments that should have been its outcome. A methodology is the design process for carrying out research or the development of a procedure and is not in itself an instrument, or method, or procedure for doing things.

Methodology and method are not interchangeable. In recent years, however, there has been a tendency to use methodology as a “pretentious substitute for the word method. Using methodology as a synonym for method or set of methods leads to confusion and misinterpretation and undermines the proper analysis that should go into designing research.

### 3.2 Experimental Setup

The process of circuit design can cover systems ranging from complex electronic systems all the way down to the individual transistors within an integrated circuit. For simple circuits, the design process can often be done by one person without needing a planned or structured design

process, but for more complex designs, teams of designers following a systematic approach with intelligently guided computer simulation are becoming increasingly common. In integrated circuit design automation, the term "circuit design" often refers to the step of the design cycle which outputs the schematics of the integrated circuit. Typically this is the step between logic design and physical design.

For the purpose of smart monitoring design, a control system circuit has been developed to monitor and secure the vehicle. A circuit diagram of the vehicle health monitoring concepts and safety techniques has been shown in the below figure.

### 3.3 Block Diagram

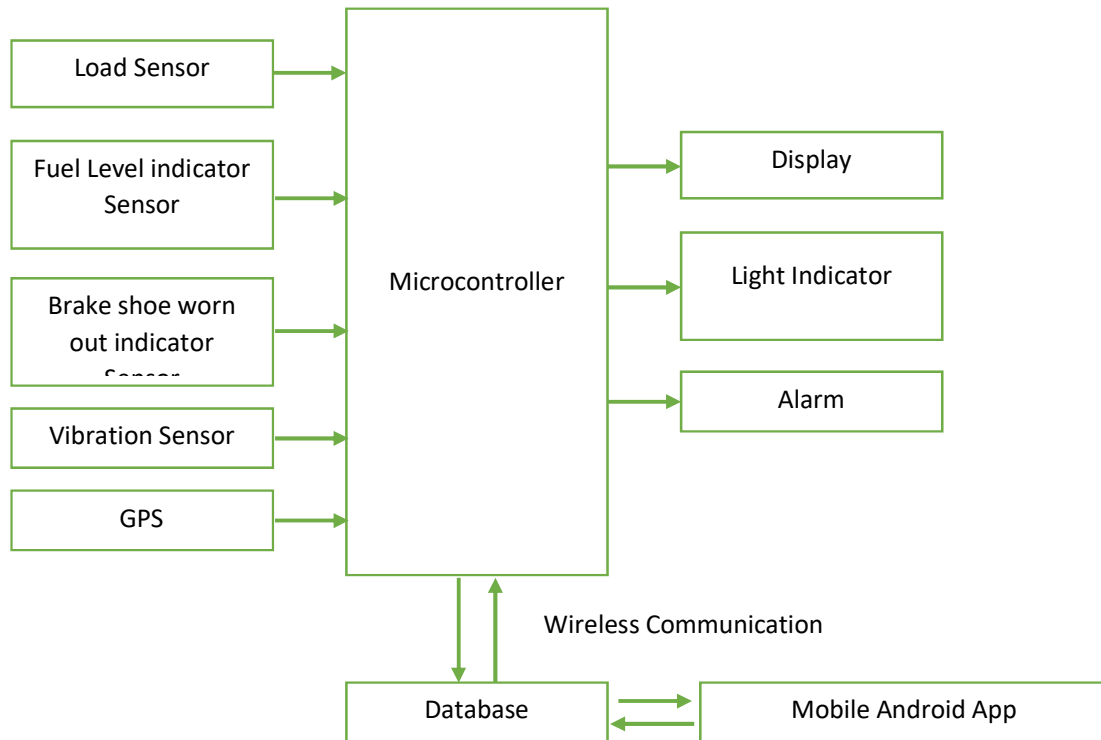

**Figure 12:** Block Diagram of this project

In this circuit, there are several inputs and output devices. Input devices are load sensor, fuel level indicator sensor, brake shoe/pad worn out indicator sensor, vibration sensor and GPS etc. Output devices are buzzer, LCD display and light indicator. A USB type 5V power supply has been used for running this circuit

### 3.4 Working Procedure

The working procedure of this project mainly depends upon the combination of the mechanical and electronic control system. To achieve the design & fabrication of an IoT based vehicle health monitoring concepts and safety techniques a scope with a fabricated load sensor, fuel level indicator sensor, brake shoe/pad worn out indicator sensor, vibration sensor, LCD Display, Buzzer, GPS and connecting wire etc.

#### 3.4.1 Fuel Level Indicator Sensor

Fuel level indicator sensor is detecting the level of fuel by the rule of resistivity. If there high-level fuel in the tank, the resistance change to low from high. According to the voltage dividing rule, here get an analogue voltage which is Arduino Nano measured. According to the analogue voltage, Arduino nano provides required digital signal to display on LCD monitor through as litter unit as well as notify through mobile apps and when the fuel level crosses a specific level (below 20 litter) then the buzzer alarming for filling up the fuel. Along with this application would be prevented from fuel theft. If the owner wants to analysis the previous record of fuel consumption from the stored database, he will also find out easily the fuel theft status. According to this the circuit block diagram are given below as per project.

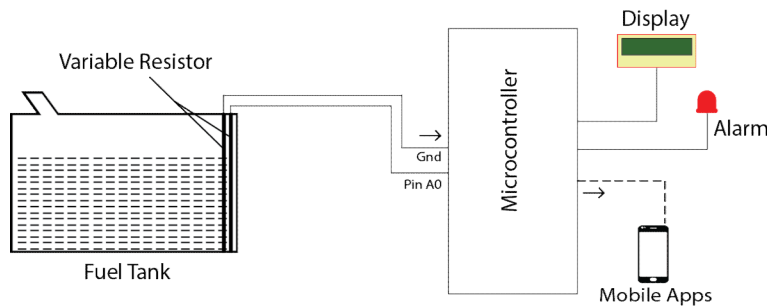

**Figure 13:** Fuel level indication Block diagram

#### 3.4.1.1 Difference between Conventional system and our system.

Fuel indicating system difference		
Content	Conventiional system provides	Our system provides
Fuel displays	Analog meter	Digital display (LCD)
Fuel Status	Watches only Driver	watched Driver as well as owner.
Data Transferring Process	Analog Meter	By iOS and Android Devices
Actula Fuel Level	Just Seems to be through indicator	Shows as litters.
Consuming calculation	Needs to know more time	knows within short time
Stolen	Posibility to Stolen	Not possible
In Low Condition	Emergency alrming not available	Emergency alrming available

### 3.4.2 Load Sensor

The load sensor is using here to detect heavy load in the vehicle. Normally in low weight can't change state. But applying heavy weight, there is change state in load sensor and sent the signal to Arduino nano. According to the input signal, Arduino nano provides required voltage to the buzzer for warn, displayed the data on an LCD monitor as well as notify through mobile apps where buzzer works as an actuator. The Flow diagram of this process is,

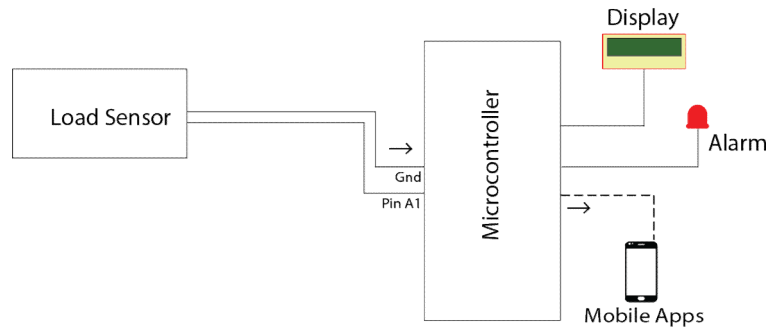

**Figure 14:** Load sensor activity block diagram

### 3.4.3 Brake Shoe/Pad worn out indicator

To design and development of brake shoe/pad, here are used PVC board and thin wire to detect the thickness of brake shoe. Here the thin wire is used into brake shoe/pad as four steps within similar distance from each other. Actually within the thin wire electron flows for closing the circuit. If a thin wire became open from the closed circuit, the Arduino detects the thin wire's circuit is open. According to consider the data, the Arduino makes an output signal to the display as a percentage through LCD monitor as well as notify through mobile apps. If the brake shoe/pad worn-out crossed the indicated level (below 20%), the Arduino provides a signal to the buzzer for beeping so that driver can aware. On the other hand the owner can notify for replacing the brake shoe/pad via mobile apps as if saving extra cost and preventing action before the accident.

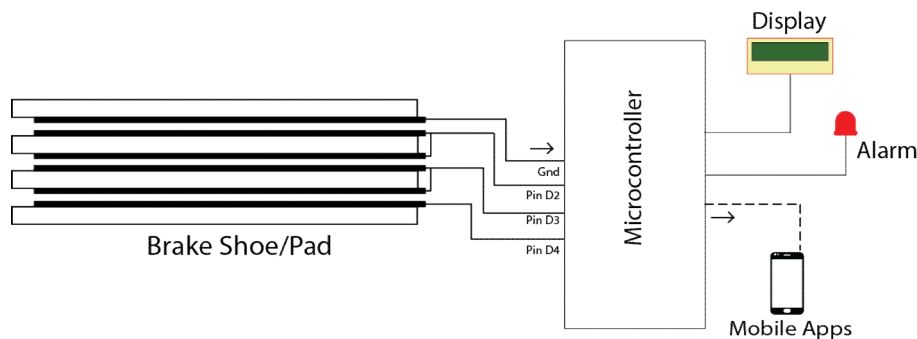

**Figure 15:** Brake pad worn out indication system block diagram

### 3.4.4 Accidental Identification

At present in the automobile industry has the many abilities to measure and monitoring systems established for looking after vehicle. We have seen that sometimes happening for a few faults the vehicles become towards accidents but the owner can't able to know about that failure incident instantly. In this project, we have developed a system that stands for notify about the accident or crashing result of the vehicle to the owner. For the failure incident we have used a piezoelectric based sensor that called vibration sensor. When vehicles could be fallen in any kind of accident, the microcontroller receives the fallen signal immediately according to the vibration of vehicles. And convert this signal into frequency so that the owner can receive the last fallen status of vehicles through mobile apps as well as knowing the surrounded people by danger alarming.

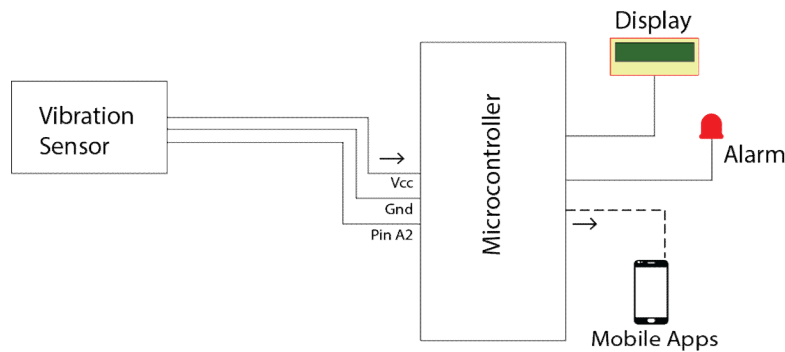

**Figure 16:** Accidental identification system block diagram

### 3.4.5 LCD Display

A liquid crystal display or LCD draws its definition from its name itself. It is a combination of two states of matter, the solid and the liquid. LCD uses a liquid crystal to produce a visible image. In this project LCD Display uses for showing the current records such as fuel in liters, brake shoe/pad worn out indicating, load condition and accidental status of vehicles. It is used for only for the microcontroller output signal.

### 3.4.6 GPS

GPS or Global Positioning System is a satellite navigation system that furnishes location and time information in all climate conditions to the user. GPS is used for navigation in planes, ships, cars and trucks also. In this project the GPS Technology assists to find out the vehicle

actual location as well as transmitting microcontroller's all output data to the owners through mobile apps. Note: In this project we have used Bluetooth technology as GPS

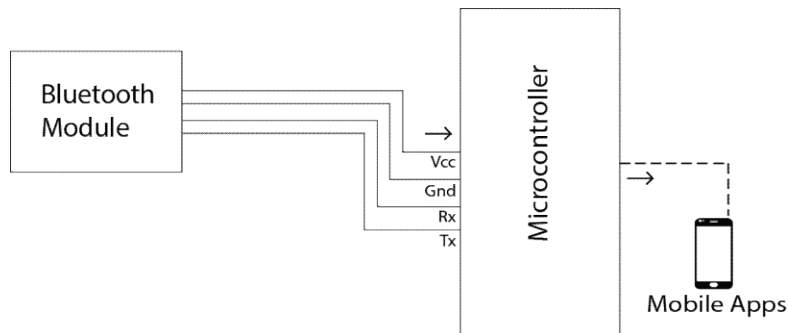

**Figure 17:** Bluetooth (GPS) tracking system block diagram

### 3.5 Procedure of Arduino board connection with Computer

At this point, it is being ready to connect Arduino to the computer. Plugging one end of the USB cable to the Arduino Uno and then the other end of the USB to the computer's USB port. Once the board is connected, it will be needed to go to Tools then Board then finally select Arduino Uno.

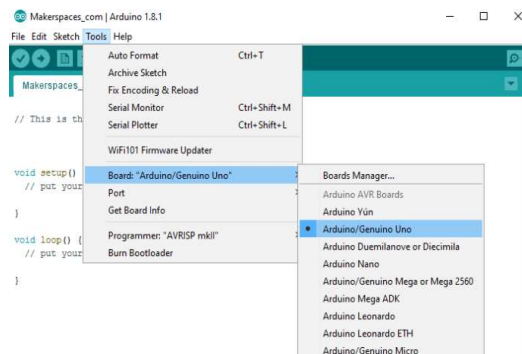

**Figure 18:** Arduino board connecting procedure

Next, we have to tell the Arduino which port are using from the computer. And for selecting the port go to Tools menu as like as the below figure.

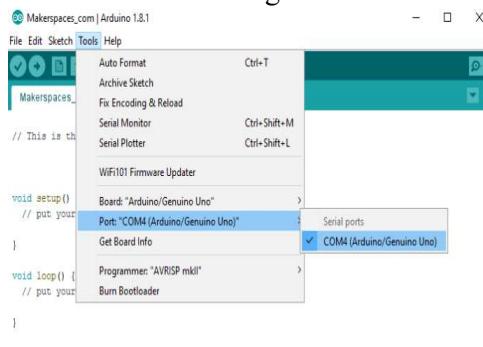

**Figure 18:** Arduino board connecting procedure

### 3.6 Arduino Board Coding

```
#include <LiquidCrystal.h>
LiquidCrystal lcd(12,11,10,9,8,7);

int vib=A5;
int fuel=A7;
int load=A3;
int br1=A0;
int br2=A1;
int br3=A2;
int led=6;
int buzzer=13;

int sig;
String percent;
void setup() {
  pinMode(load,INPUT_PULLUP);
  pinMode(br1,INPUT_PULLUP);
  pinMode(br2,INPUT_PULLUP);
  pinMode(br3,INPUT_PULLUP);
  pinMode(led,OUTPUT);
  pinMode(buzzer,OUTPUT);
  lcd.begin(16, 2);
  Serial.begin(9600);
}

void buz()
{
  digitalWrite(led,1);
  digitalWrite(buzzer,1);
  delay(2000);
  digitalWrite(buzzer,0);
  delay(3000);
  digitalWrite(led,0);
}

void loop() {
  if(digitalRead(br3)==0) percent="100%";
  else if(digitalRead(br2)==0) percent=" 75%";
  else if(digitalRead(br1)==0) percent=" 50%";
  else {percent=" 25%";buz();}

  Serial.print(percent);
  Serial.print(analogRead(fuel));
  Serial.print("%");
  Serial.print(digitalRead(load));
  Serial.print("%");
  Serial.println(digitalRead(vib));
```

```

if(digitalRead(load)==0)
{

  lcd.setCursor(0, 1);
  lcd.print("Overload");
  buz();
}
else
{
  lcd.setCursor(0, 1);
  lcd.print("Normal ");
}

if(digitalRead(vib)==1)
{
  lcd.setCursor(9, 1);
  lcd.print("Danger!");
  buz();
}
else
{

  lcd.setCursor(9, 1);
  lcd.print("Safe ");
}

  lcd.setCursor(0, 0);
  lcd.print("Fuel:");
  if(analogRead(fuel)<=99)
  {
    lcd.setCursor(7, 0);
    lcd.print(" ");
  }
  lcd.setCursor(5, 0);
  lcd.print(analogRead(fuel));
  if(analogRead(A7)<=20) buz();

  lcd.setCursor(9, 0);
  lcd.print("BP:");
  lcd.setCursor(12, 0);
  lcd.print(percent);

  delay(1000);
}

```



### 3.7 Apps Development

We have used the thinkable developer for making our apps. By which the owner will easily monitor his vehicle health condition as well as others parameter's as his demand. The code of this apps thinkable is given below.

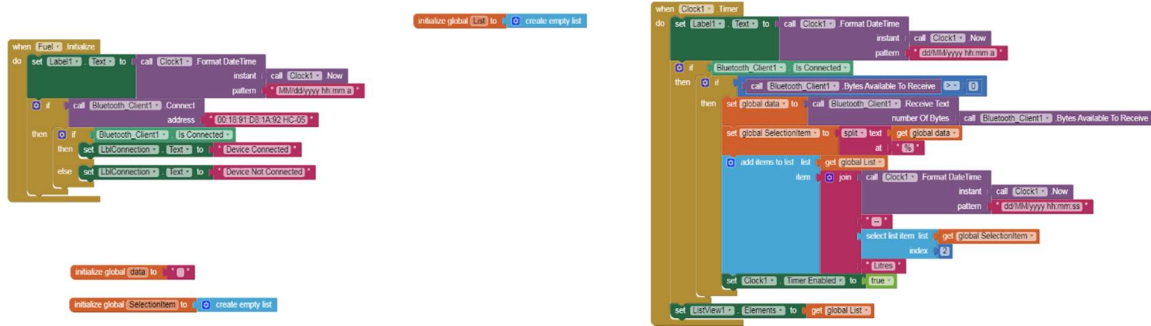

Figure 19: Overall Apps developing coding dashboard

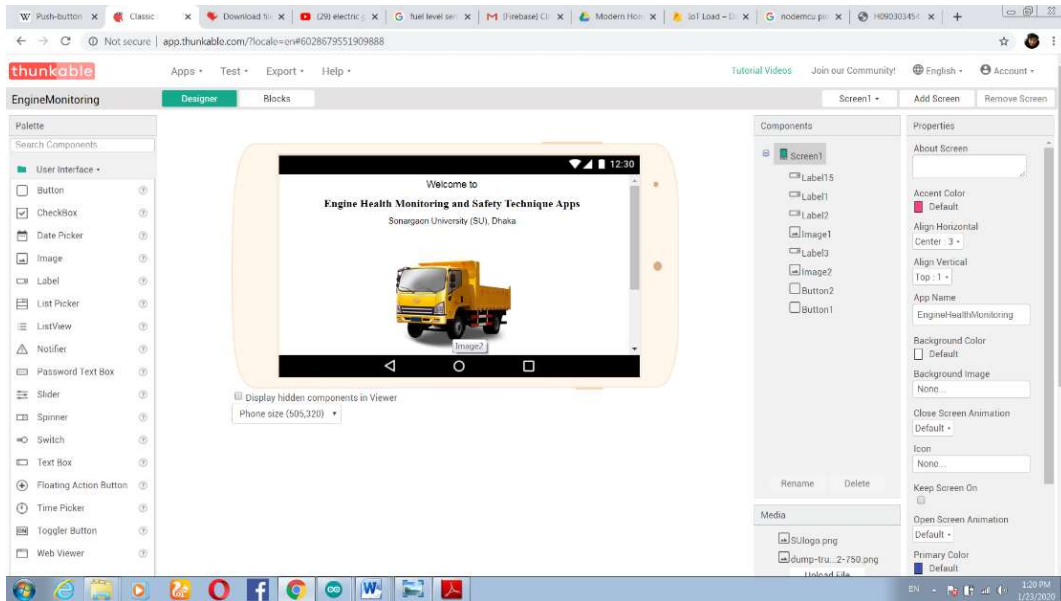
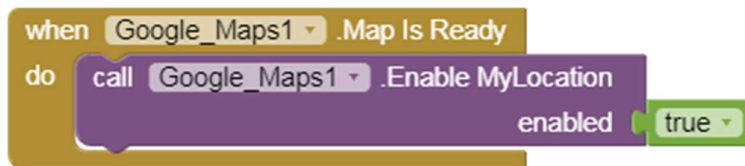

Figure 20: Apps developing a dashboard

#### 3.7.1 Others Parameters code



```

initiate global [data] to ""
initiate global [selectionItems] to [] create empty list

when Screen0.Initialize
do if Bluetooth_Client1.Connect
  address [192.168.1.1:5555]
  then if Bluetooth_Client1.Is Connected
    then set [btConnection] Text to Device Connected
    set [btConnection] Text to Vehicle in Safe mode
    set [btConnection] Text to
  else set [btConnection] Text to Device Not Connected

when [btLocation].Click
do open another screen screenName [Screen3]

when [Click1].Times
do if Bluetooth_Client1.Is Connected
  then call Bluetooth_Client1.Bytes Available To Receive
  number Of Bytes call Bluetooth_Client1.Bytes Available To Receive
  set [global data] to call Bluetooth_Client1.Receive Text
  set [global SelectionItems] to []
  select list item list [global data] at [0]
  set [btBroadcast] Text to [0] join [global SelectionItems]
  index [0]
  set [btBroadcast] Text to [0] join [global SelectionItems]
  index [0]
  if select list item list [global SelectionItems]
  index [0]
  then set [btBroadcast] Text to [0] join [global SelectionItems]
  index [0]
  set [btBroadcast] Text to [0] join [global SelectionItems]
  index [0]
  if select list item list [global SelectionItems]
  index [0]
  then set [btBroadcast] Text to [0] join [global SelectionItems]
  index [0]
  else set [btBroadcast] Text to [0] join [global SelectionItems]
  index [0]

when [btBroadcast].Click
do set [btBroadcast] Text to Vehicle in Safe mode
set [btBroadcast] Text to

when [btBroadcast].Click
do set [btBroadcast] Text to Vehicle in Safe mode
set [btBroadcast] Text to

when [Button1].Click
do open another screen screenName [Screen2]

when [Button2].Click
do open another screen screenName [Screen4]

```

Figure 21: Apps developing code of all

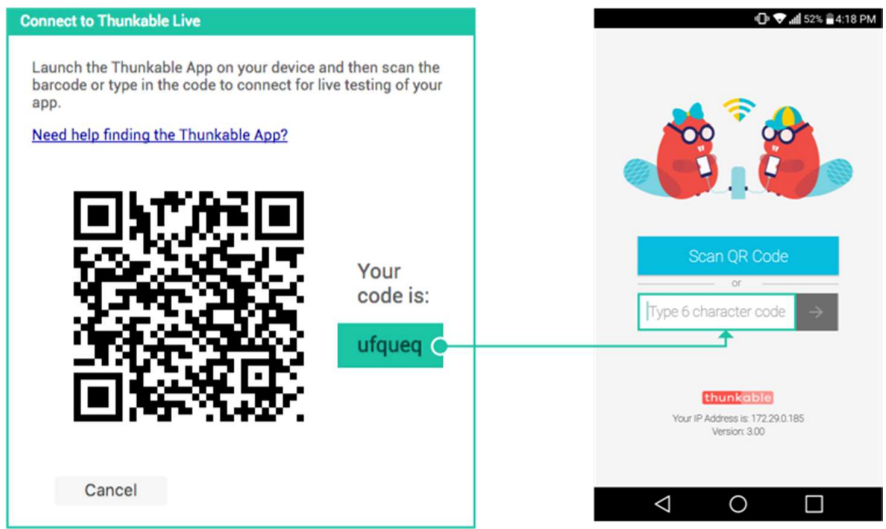

Figure 22: Live test in Thinkable panel

### 3.8 Overview of thinkable

Thunkable X is a cross-platform app builder that enables anyone to build their own native mobile apps. All apps built on Thunkable X work for both Android and iOS devices.

Thunkable enables anyone to create beautiful and powerful mobile apps. On Thunkable, every app project you create works on both Android and iOS devices.

App Inventor is a blocks-based programming tool that uses the source code in the AIA file to create applications. The AIA file is also used to export and import projects to and from a computer to the web program. You can share your project in an executable form, which is the APK file, instead of source code form.

Surprisingly, the .aia file is just a regular .zip file. You can verify by saving a copy to your local disk drive, and then rename the file to have a .zip file extension instead of .aia. Then use Windows Explorer, StuffIt Expander or other utility to open and decompress the .zip file.

# CHAPTER 4

## RESULT & DISCUSSION

### 4.1 Introduction

The project IoT based vehicle health monitoring safety techniques concepts was completed successfully.

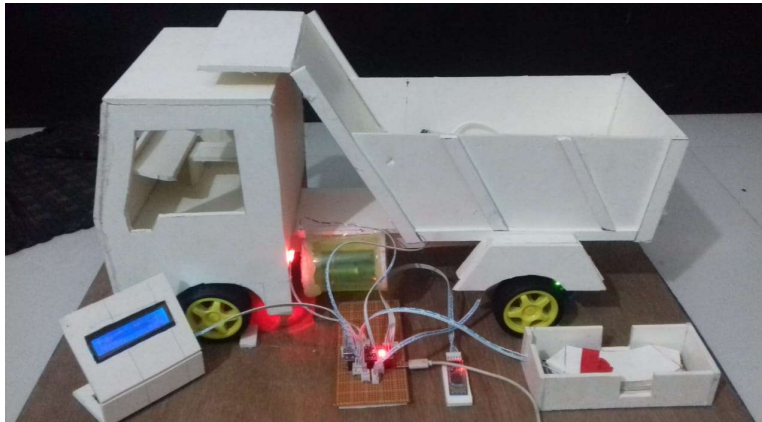

**Figure 23: Project Overall View**

The monitoring of vehicle data is successfully by android application & Bluetooth module. In here, the load sensor can sense heavy load in the vehicle and sent data to mobile apps, fuel level indicator is measured by a variable resistor of the level of fuel and it also sent its data. In this project, the fuel tank is actually 155 ml. According to the variable resistance, output fuel is shown in liters which chart are given below.

Fuel Level	Voltage (V)	Resistance (ohm)
Empty (0 ml)	3.96	419
40 ml	3.65	410
80 ml	3.46	398
120 ml	3.29	385
Full (155 ml)	3.18	379

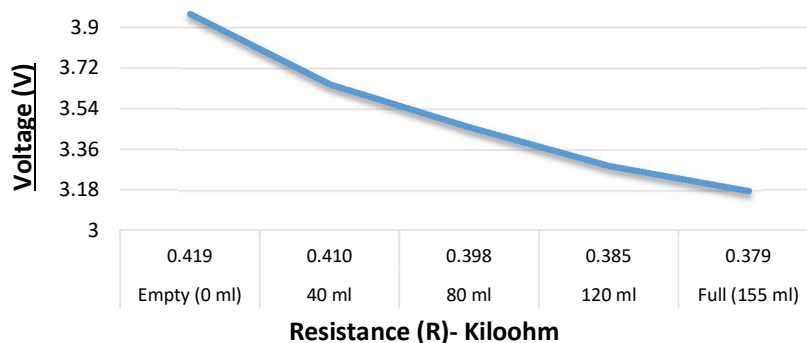

On the other hand, GPS indicates the current location of the vehicle. Buzzer and display help driver to recognize the current stage/condition of the vehicle. As well as in this project we have used a new concept of brake shoe which already discussed. The result of this brake pad is given below that how the amount of brake pad worn out it will display according to layer worn out.

Worn out Layer	Displayed (%)
New Brake Pad	BP 100%
1st Layer	BP 75%
2nd Layer	BP 50%
3rd Layer	BP 25%
<b>When worn out reached the 3rd layer, the LED blinking and buzzing for information</b>	

Brake Pad worn out Output

Finally, all data stored to android mobile which is operated by the owner. In the android app, there have more than 2 slots to add more vehicle. That's why every individual owner can monitor current data of vehicles by a single app.

#### # Others output results:

Load Status	Displayed	Dashboard Signal
Normal load Condition	Normal	
Overload condition	Overload	Aarming
<b>Note: Which signal display on dashboard, the same data shows in mobile apps</b>		

Load Condition Output

Status	Displayed	Dashboard Signal
Noraml	Safe	
Major Accident	Danger!	Aarming
<b>Note: According ot dashboard signal,into mobile apps shows as " Vehicle Fallen in accident"</b>		

Accidental information output



Figure 24: Apps Output Panel 1

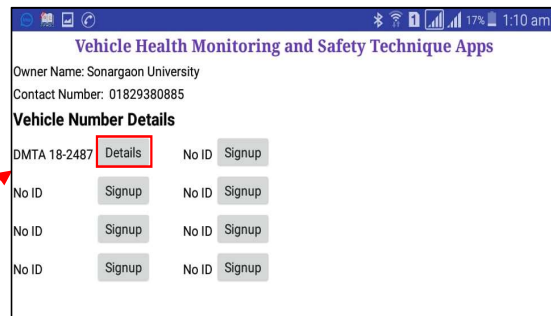

Figure 24: Apps Output Panel 2

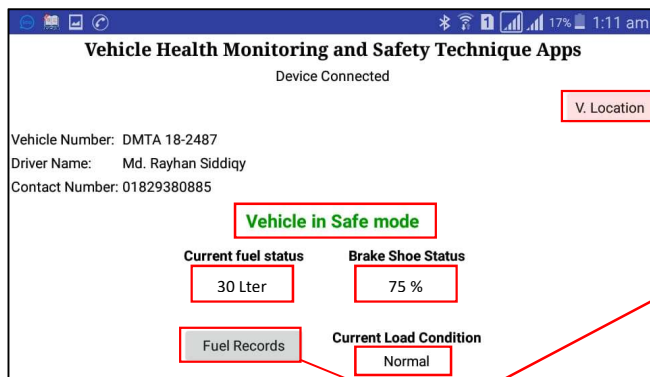

Figure 24: Apps Output Panel 3

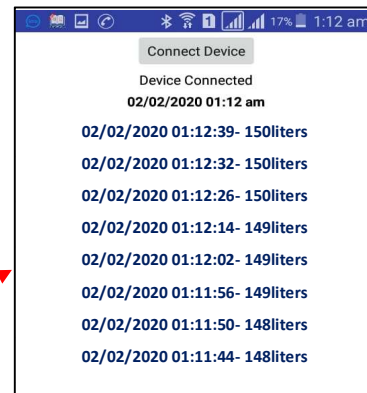

Figure 24: Apps Output Panel 4

## 4.2 Project side overview



Figure 25: Project Display



Figure 25: Brake pad demo

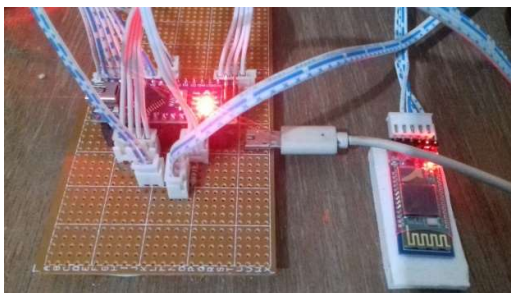

Figure 25: Micro controller board with all collection



Figure 25: Fuel tank with the sensor connected

# CHAPTER 5

## CONCLUSION

### 5.1 Conclusion

With the co-operation of microelectronics technology, we can apply electronics and programmable related device within automobiles several systems where it could increase the efficiency, security and longevity of an automobile as well as providing digitalize service for consumers. Within this project, we have tried to show the actual calculation of fuel (in liters), the actual worn out of brake shoe/pad (percentage) and the indication of fuel theft, excess load detection and accidental location of vehicles. Each output data driver can see onto the dashboard even owner can know all of it through mobile application wherever the owner stays. We optimize, the mobile application and the systems would be more beneficial for owners. As commercially we can get scopes for attaching or installing our project, it will secure the vehicle, reduce maintenance cost and look after from wherever wants. Each system of this project is customer demands from the field study we have abled to understand. So we have inspired to develop this project.

# REFERENCE

## Reference

- [1] Kargupta, Hillol, et al. "VEDAS: A mobile and distributed data stream mining system for real-time vehicle monitoring." Proceedings of the 2004 SIAM International Conference on Data Mining. Society for Industrial and Applied Mathematics, 2004.
- [2] Kargupta, Hillol, et al. "On-board vehicle data stream monitoring using mine fleet and fast resource-constrained monitoring of correlation matrices." New Generation Computing 25.1 (2006): 5-32.
- [3] Last, Mark. "Vehicle failure prediction using warranty and telematics data." Learn. Vol. 29. No. 3. 2011.
- [4] Kargupta, Hillol. "Onboard vehicle data mining, social networking, advertisement." U.S. Patent No. 8,478,514. 2 Jul. 2013.
- [5] Stewart, Gilbert W. "Matrix perturbation theory." (1990).
- [6] VEHICLE HEALTH MONITORING SYSTEM M.Jyothi Kiran, S.Ravi Teja
- [7] IoT Based Vehicle Health Monitoring System Yogesh Kr. Mallick, Anamika Talukdar, Debleena Bhattacharjee, Sandipan Roy
- [8] [en.wikipedia.org/wiki/Load\\_cell](https://en.wikipedia.org/wiki/Load_cell)
- [9] [howtomechatronics.com/tutorials/arduino/arduino-and-hc-05-bluetooth-module-tutorial/](http://howtomechatronics.com/tutorials/arduino/arduino-and-hc-05-bluetooth-module-tutorial/)
- [10] [elprocus.com/vibration-sensor-working-and-applications/](http://elprocus.com/vibration-sensor-working-and-applications/)