



Faculty of Engineering
Department of Textile Engineering

REPORT ON
Industrial Attachment
At
Amazing Fashions Limited

House # 445, Road # 07, DOHS,
Baridhara, Dhaka-1206, Bangladesh

Course Title: Industrial Attachment
Course Code: Tex-442

Submitted By:

Submitted By:	ID Number	Group (E)
Amran hossen	TEX1801013049	(E)
Ashikur Rahman	TEX1801013087	(E)
Md.Shafiqul Islam	TEX1701010032	(E)
Md Maznu Hasan	TEX1801013148	(E)
Md Anwarul Islam Sawon	TEX1801013058	(E)

Academic Supervised
Kamrul Hassan Bhuiyan
Coordinator & Lecturer
Department of Textile engineering
Sonargaon University (SU)
146 Mohakhali, Wireless Gate. Dhaka

This report we have presented in partial fulfillment of the requirement for the Degree of
Bachelor of Science in Textile Engineering.

Advance in Apparel Manufacturing Technology
Duration: From 20 February 2021 to 25 May 2021



Letter of Transmittal

Date_____.

Md Kamrul Hassan Bhuiyan

Co-Ordinator

Sonargaon University (SU)

Subject: Submission of industrial training report.

Dear Sir,

With due respect, we the students of Textile Engineering, Sonargaon University (SU) have successfully completed our industrial training program. In this stage we are submitting our industrial training report as part of our B.Sc. in Textile Engineering Degree requirement that bears three (03) credit hours under your supervision. We are submitting this report for our academic purpose only. Please be kind enough to evaluate this dissertation with your valued suggestions.

Sincerely yours

(1) Amran hossen
ID:Tex.1801013049

(2) Ashikur Rahman
ID:Tex-1801013087

(3) Md.Shafiqul Islam
ID:Tex-1701010032



DECLARATION

We hereby declare that, this Industrial Attachment on **Amazing Fashions Limited** of Bangladeshis done by us under the supervision of **Kamrul Hassan Bhuiyan, Coordinator & Lecturer**, Department of Textile Engineering, **Sonargaon University (SU)**, Dhaka. We also declare that, this Industrial Attachment report has not been submitted anywhere for award, degree or diploma. We ensure that, any part of this attachment has been presented anywhere.

(1) Amran hossen
ID:Tex.1801013049

(2) Ashikur Rahman
ID:Tex-1801013087

(3) Md.Shafiqul Islam
ID:Tex-1701010032

(4) Md Maznu Hasan
ID:Tex-1801013148

(5) Md Anwarul Islam Sawon
ID:Tex-1801013058



LETTER OF APPROVAL

This is to certify that Amran hossen, ID:Tex.1801013049, Ashikur Rahman, ID:Tex-1801013087, Md.Shafiqul Islam, ID:Tex-1701010032, Md Maznu Hasan, ID:Tex-1801013148, Md Anwarul Islam Sawon, ID:Tex-1801013058 BSC Engineering Textile program, 13B Batch have successfully completed their Industrial Internship on Apparel Manufacturing Technology under my supervision. I do hereby approve their report. I also recommend accepting their report for partial fulfillment of Bachelor of Science in Textile Engineering (BSCTE) Degree.

.....

Kamrul Hassan Bhuiyan

Coordinator & Lecturer

Department of Textile Engineering

Sonargaon University (SU), Dhaka



ACKNOWLEDGEMENTS

First of all, we would like to express my gratitude to **Almighty Allah** to enabling me to complete this report on “**Report on Industrial Training**”.

Successfully completion of any type of project requires helps from a number of persons. We have also taken help from different people for the preparation of this report. Now, there is a little effort to show our deep gratitude to that helpful person.

We would like to express our deepest appreciation and sincerest gratitude to our respected Co-ordinator Sir, **Md Kamrul Hassan**, Department of Textile Engineering, Sonargaon University, for his valuable guidance, suggestion, encouragement, and inspiration throughout this industrial training period.

We would also like to express our foremost gratitude to officials of **Amazing Fashions Limited** who helped us and gave their valuable time, providing us with the most relevant information on the basis of which we have prepared this report. We are thankful to all of them for helping and guiding us and for being nice and kind to us.



ABSTRACT

For any technical education, practical experience is almost equal important in association with the theoretical knowledge. By means of practical knowledge it's not possible to apply the theoretical knowledge in the practical field.

Industrial attachment is the first step to professional life of student, especially of technical side. It's an indispensable part of study a practically running processing technology of an industrial unit for a student. University education provides us vast theoretical knowledge as well as more practical attachment, in despite of all these industrial attachment helps us to be familiar with technical support of modern machinery and skills about various processing stages.

This internship provides me sufficient practical knowledge about production management, efficiency, industrial management, pattern, cutting, sampling, washing, Finishing, Costing, purchasing, inventory control, utility and maintenance of machineries and their operation techniques etc. which cannot be achieved successfully by means of theoretical knowledge only.

We were able to study on their different sections and their activities practically. Due to some limitation of the factory, we have found store section, cutting section, sewing section, finishing section and maintenance section, costing section washing section. Here we have also found the sample section but this section isn't fully operational as here only the Development sample, size set and production samples are produced.

All the activities of this factory are performed according to the central orders of the company. This company works for Academy buyer and sometimes works for Pritha which is an own buying house of this group of company.

During my internship we got the opportunity to study on some orders, from order receive to the delivery of the order. With the help of my supervisor we have acquired the knowledge of handling an order, the production procedure and the inspection procedure to maintain the quality of these orders. We have also learnt about the office management of this factory.



Table of Contents

Letter of Transmittal.....	1
Declaration	2
Letter of Approval	3
CHAPTER-1	11
1.1 Executive Summary	12
CHAPTER-2	13
Factory Profile.....	14
Amazing Fashions Ltd.	14
CHAPTER-3	16
Ball Warping.....	17
Slasher Dyeing	18
Rope Dyeing.....	19
LCB : Long Chain Beam	20
SIZING.....	21
WEAVING.....	21
Machine Parts of Singeing.....	22
CHAPTER-4	24
Flow Chart of Amazing Production:	25
Part-1.....	26
Direct Warping.....	26
Types of Creels	26
Magazine Creels	27
Direct Warping.....	28
Direct warping process flow chart.....	28
Yarn Suppliers.....	28
Package Length	28
Time Study.....	28
Direct warping machine parts name	29



Direct warping machine parts name	29
Ball Warping.....	29
Ball warping process flow chart.....	30
Yarn supplier	30
Time Study.....	30
Fault of Ball Warping	31
Long chain beamer (LCB).....	31
Time Study.....	32
Lcb important parts.....	32
LCB Problems	32
Part-2(dyeing & sizing) Dyeing.....	33
Slasher / Sheet Dyeing:	33
The passage of flow of yarns in slasher dyeing is shown below.....	34
Pre Treatment	34
Washing.....	34
Dyeing (Indigo blue dye).....	35
Washing.....	35
Drying.....	35
Accumulator	35
4.4.8 Sizing	35
Drying.....	35
Advantages of Slasher / Sheet Dyeing:.....	35
Advantages	36
Color Dyeing Arrangement.....	36
Indigo dye recipe.....	36
Sulpher Dye Recipe.....	37
Dyeing Fault	37
Rope Dyeing.....	38
The passage of yarn in rope dyeing is as follows	39
Color Dyeing Arrangement	40
Recipe Calculation	40



Dyeing Result.....	40
Machine Problem	41
Sizing	41
Objectives of Sizing.....	42
Types of Sizing.....	43
Disadvantages of Sizing	43
Flow Chart for Sizing of Warp Yarn:	44
Sizing Chemicals.....	44
Sizing Faults Causes.....	45
Part -3 Weaving.....	48
Weaving.....	48
Classification of Weaving Machine	48
Shuttle Weaving	49
Projectile Weaving	49
Rapier Weaving.....	50
4.8.6 Air Jet Weaving.....	52
Basic Weaving Mechanism.....	53
Primary Motion.....	53
Secondary Motion.....	58
Auxiliary Motion.....	59
Amazing Fashions Weaving.....	61
Weft Count.....	63
Wastages 63	
Various Types Reed Used	63
Cam Setting.....	64
Weaving Faults	64
Selvages 65	
Machine Parts Name	65
Finishing.....	69
Benefits of Finishing.....	69
Classification of Finishing	70



Singeing Machine	71
Benefits of Singeing.....	71
Machine Parts of Singeing.....	71
Machine parameter	71
Special Checkpoints	72
Cleaning Area of Singeing.....	72
Osthoff Singeing Parameter According to GSM.....	72
Benefits of Sanforizing	73
Machine Parts Sanforizing	73
Machine Parameters Sanforizing.....	74
Process Parameters of Sanforizing	74
Stenter Machine Machine parts of stenter.....	77
Function of Stenter.....	78
Process Parameter of Stenter Machine	78
De-sizing 79	
Benefits of de sizing.....	79
Machine Parts of Desizing	79
Process Parameter of De-sizing.....	79
Chemical Recipe of De-sizing.....	80
Cleaning Area of De-Sizing	80
Mercerizing.....	80
Benefits of Mercerizing.....	80
Machine parts of Mercerize.....	81
Process Parameter of Mercerize	81
Chemical Recipe of Mercerize	81
Chemical Area of Mercerize Machine.....	82
Special Care of Mercerize.....	82
Over Dyeing	82
Bleaching 83	
Inspection.....	84
Objectives	84



4-Points System.....	85
Procedure of 4-Points System.....	85
Fabric defects point values based on the following	86
4.10.7 List of defects in woven fabric is given bellow.....	86
Testing	88
Test Name	88
Apparatus	88
Conditioning.....	88
Preparation.....	88
Marking	88
Washing	89
Machine Cycle.....	89
Washing Temperature.....	89
Drying	89
Measurement.....	89
Calculation.....	89
Yarn and Chemical quality checking before production	89
Lab Q.A - (Testing) - Activities system	91
The testing Facilities Available in HDL lab.....	91
Amazing Washing.....	92
Process of Amazing Washing.....	92
Different Types of Washing Vault.....	93
CHAPTER-5	94
Mechanical store.....	95
Schedule maintenance.....	95
Dyeing Machines maintenance.....	95
Weaving machine maintenance	96
Finishing maintenance	96
CHAPTER-6	98
Inventory:	99
Type of Inventory in HDL.....	99



CHAPTER-7	101
Definition	102
Flow chart of marketing:	102
Activities of Marketing	103
Duties and Responsibilities:	103
CHAPTER-8	105
8.1 Introduction	106
CHAPTER-9	108
Introduction	109
Work Flow Chart of R & D Section	110
Conclusion	111



CHAPTER-1

EXECUTIVE SUMMARY

1.1 Executive Summary

Textile education cannot be completed without industrial training, because this industrial training minimizes the gap between theoretical and practical knowledge and make accustomed to industrial environment. Without adequate practical experience it is impossible to understand theoretical aspects and its implication. Industrial attachment is the process, which builds understanding, skills and attitude of the performer, which improve one's knowledge in boosting productivity and services. Through this attachment, we can know about theoretical implementation on industrial basis. We can know more about the machineries used at the different departments and their technical specifications, parameters, operating system, etc. and we think without doing this type of industrial attachment it is not possible to acquire industry based knowledge properly about textile engineering.

This report has been arranged on the basis of Industrial Attachment on Amazing Manufacturing Technology (Warping, Dyeing, Sizing, Weaving, Finishing, Inspection, Planning and R&D). Here in this report we present different working procedure for production of Amazing of the industry. we are present here the procedure and process of different types of warping system, dyeing method, weaving, fabric inspection, pretreatment, laboratory processing, quality control, finishing, necessary information about utilities, number of machines, machine specifications, manpower, organogram, maintenance, name of the buyer, production capacity, dyes and chemicals, layout of the different section, work shift.

Our internship period was between from 24th February, 2020 to 23th April 2020 for two months in Amazing Fashions ltd.



CHAPTER-2

INFORMATION ABOUT FACTORY

Factory Profile

Amazing Fashions Limited, a Bangladeshi clothing manufacturer, is leading supplier of readymade garments and Amazing fabric in the world. We are one of the top clothing companies in Bangladesh. The company produces some of the most fashionable Amazing fabrics and garment products and owns one of the most comprehensive and resourceful manufacturing facilities in Bangladesh.

Amazing Fashions Limited has earned name and fame both at home and abroad as one of the top clothing companies in Bangladesh. The continuous growth of this group is moving forward hand on hand with the industrialization of the home country Bangladesh. Moreover we as a Bangladeshi clothing manufacturer have been contributing immensely in the financial growth of the nation.

Amazing Fashions Limited, one of the top clothing companies in Bangladesh exporting to USA and Europe for a long time. Because of our successful history with the world leading customers and buyers, we are the most valued and well reputed Bangladeshi clothing manufacturer.

Company produces 7 million pcs of woven garments per month with the assortment of infant to adult in men and women. Today Amazing Fashions Limited employs around 50,000 workers and the company is equipped with 26 garments factories, a unique Amazing mill, Sweater factory, Embroidery and Printing factory, Carton factory, Poly bag industry, Label factory, Jute mill, Chemical formulation plant, Tea Gardens, Transport company, News Channel and a national daily Newspaper. Its overseas office in Hong and China gives fastest support in procurement of fabric and accessories. Own C & F office in every Bangladeshi port gives privilege of quick clearing and forwarding support.

Amazing Fashions Knit will start within a year. It will have capacity of 10 tons composite knit which will be increased to 50 tons in phases. It will make all types of knit products like tops & bottoms for man, women and children.

Amazing Fashions Ltd.

Amazing Fashions is vertical in Amazing. It has an installed capacity of over 6 million meters per month. It is equipped with Picanol looms, Open-end Spinning, Flat Finishing, Mercerizing, Sucker Muller Slasher-dyers and Wet Finishing processes on Morisson machines. A remarkable

Rope dyeing unit from Morison can produce high depth, pure indigo and other innovative shades adding value to the impressive product portfolio. Amazing Fashions has a high tech finishing and mercerizing set up along with stenter and coated finishing to create premium finishes. Amazing Fashions produces its own yarns from its own spinning mill with capacity 44 tons daily, with all stages of in-house capability; Amazing Fashions becomes vertical in both Amazing and Woven.

Presently we are using our own Amazing fabric for GAP, JC Penney, KOHL'S, PVH, H&M, NEXT in their different products.

Amazing Fashions produces yarns from its own Spinning Mill with a capacity of 44 tons per day.

Amazing Fashions Amazing Mills Ltd.

House # 445, Road # 07, DOHS,
Baridhara, Dhaka-1206, Bangladesh



CHAPTER-3 MACHINE IDENTIFICATION

Ball Warping

Machine No 01

Brand name: ukil Model: GSSM-100

Origin: Korea Creel capacity:480

Dia of dram: 1600 mm Beam capacity: 1250
kg

Machine speed: max 800 rpm (600 rpm
average)



Figure 3.1: ukil Model: GSSM-100

MACHINE NO: 02

Brand name: PANON Model: 067

Origin: Taiwan Creel capacity: 650

Dia of dram: 1800 mm Beam capacity: 1050
kg

Machine speed: max 800 rpm (600 rpm
average)



Figure 3.2: PANON Model: 067

MACHINE NO: 03

Brand name: SUKER MULLER Model:
07552

Origin: GERMANY Creel capacity: 480 Dia
of dram: 1600 mm

Beam capacity: 1250 kg

Machine speed: max 800 rpm (600 rpm
average)



Figure 3.3: SUKER MULLER Model: 07552

Slasher Dyeing

Machine no: 01

Brand name: SUKER MULLER Origin: GERMANY

Model: 07552

Beam capacity: 16*2= 32

Chemical bath: 15

No of dye bath: 09

No of wash bath: 6(3-30)

Beam dia: 458 mm

Mixer tank; 06

Reserve tank: sizing-01

Beam width: 1600 mm



Figure 3.4: SUKER MULLER Origin: GERMANY

Machine no: 02

Brand name: PANON Origin: TAIWAN

Model: 077

Beam capacity: 12*2= 32

Chemical bath: 17

No of dye bath: 10

No of wash bath: 5 (2-3)

Beam dia: 458 mm Mixer tank: 05

Reserve tank: sizing-01

Beam width: 1800 mm



Figure 3.4: PANON Origin: TAIWAN

Rope Dyeing

Machine no :01

Brand name: SMARTEC

Origin: CHINA

Model: LHJ-3689-96

Ball capacity: 80

Chemical bath: 18

No of feed tank: 13

No of wash bath: 6 (3-3)

Machine speed: 25 mpm Creel

Capacity: 40 rope

Dye bath: 10

Wash bath temp: 50 deg C Can

capacity: 40

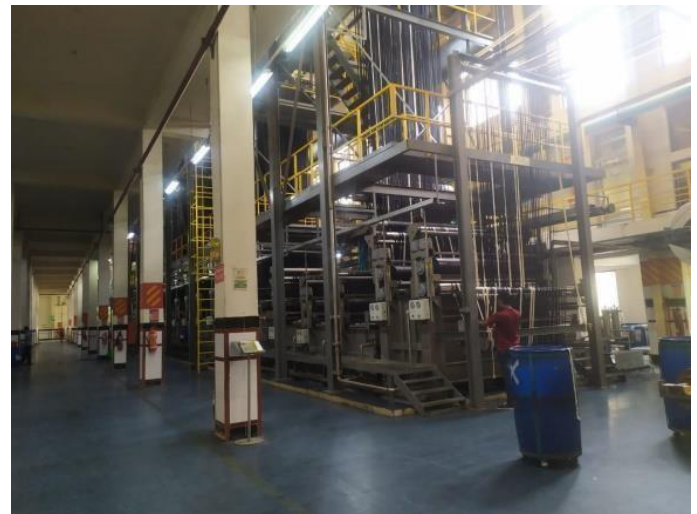

Figure 3.5: SMARTEC



Machine no :02

Brand name: MORRISON

Origin: USA

Ball capacity: 82

Chemical bath: 18

No of feed tank: 13

No of wash bath: 6 (3-3)

Machine speed: 25 mpm

Creel capacity: 40 rope

Dye bath: 10

**Wash bath temp: 50 deg C Can
capacity: 40**



Figure 3.5: MORRISON

LCB : Long Chain Beam

Brand name: KARL MAYER

Origin: GERMANY

Capacity : One Ball

Reed : 420

Speed : 180-240 Count wise



Figure 3.6: KARL MAYER

SIZING

Brand name: KARL MAYER

Origin: GERMANY

Size box: 02

Beam capacity: 28 but used 20



Figure 3.7: KARL MAYER

WEAVING

Rapier loom (Cam)

Brand name: PICANOL optimax Origin: Belgium

Machine speed: 700 rpm Machine effi: 90%

No of heald frame: 6

Shedding mechanism: positive cam shedding

Beam width: 190 cm



Figure 3.8: PICANOL

Rapier loom (Dobby)

Brand name: PICANOL optimax -i Origin: Belgium

Machine speed: 680 rpm Machine effi: 90%

No of heald frame: 12

Shedding mechanism: positive dobby shedding Beam width: 220 cm

Machine weight: 4000kg

Air jet loom:

Brand name: PICANOL OMNIplus SUMMUM Origin: Belgium

Machine speed: 1000 rpm Machine effi: 95%

No of heald frame: 6

Shedding mechanism: positive cam shedding Beam width: 220 cm

Machine weight: 3500kg

Machine Identification

Brand : Osthoff singeing

Origin : Germany

No. burner 02

Speed : (50-150) mpm

Intensity : (6-20)mbar

Singeing : Both side

Type of m/c : Gas singeing



Figure 3.9: Singeing

Machine Parts of Singeing

- J-box unit
- Brushing unit
- Burner unit
- Beating unit
- Batching unit

Machine parameter

- Machine speed,
- Burner intensity,



- Brushing intensity
- Beating intensity
- Dust collector
- Water spray
- Plain sewing,
- Over lock sewing,
- Sewing thread count

Machine Identification

Brand : Morrison

Origin : USA

Speed : (10-80) mpm

Dryer :03



Figure 3.10: Morrison



UGC & Govt. Approved

Sonargaon University (SU)

সোনারগাঁও ইউনিভার্সিটি (এসইউ)

WE WILL
RISE UP
WE WILL
SHINE

CHAPTER-4

PRODUCTION SEQUENCE AND OPERATION



Flow Chart of Amazing Production:

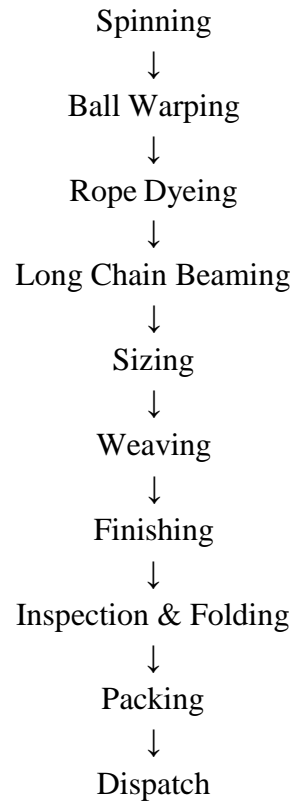

Part-1 (Direct Warping, Ball warping, long chain beamer)

Direct Warping

Warping is the process of transferring multiple yarns from individual yarn packages onto a single package assembly. Normally, yarns are collected in a sheet form where the yarns lie parallel to each other and in the same plane onto a beam, which is a cylindrical barrel with side flanges. This is known as beam warping and is shown in Figure 2. For ball warp Amazing, the yarns are brought together and condensed into a rope before being wound onto a relatively short cylindrical barrel (sometimes called the shell or log) that has no end flanges. This is shown in Figure 3. In both cases, the supply yarn packages are placed on spindles, which are located in a framework called a creel.

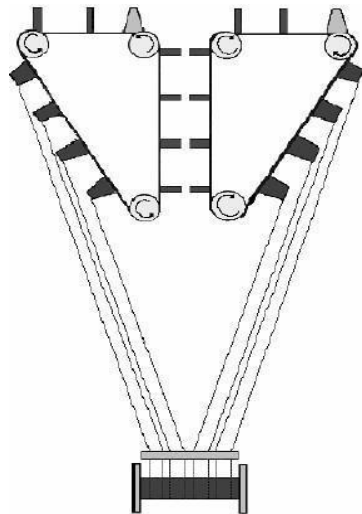

Figure 2. Beam Warping

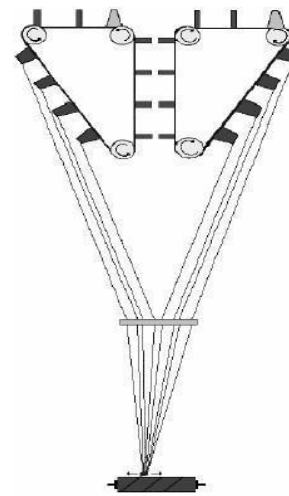

Figure 3. Ball Warping
(Rope)

Types of Creels

Traveling Package Creels

These are V-shaped creels with the actively running yarn packages on the outside of the V and the full yarn packages placed on the inside of the V. When the running packages are depleted, the yarn spindles on the creel are rotated so that the empty packages move to the inside of the creel for replenishment. The full packages move to the outside of the creel. The new yarn ends have to be pulled forward and threaded properly in the machine before

Running the next warp. The empty package positions are then replaced with new full packages while the warper is running. This eliminates lost time in creeling up new yarn packages.

Magazine Creels

These are straight-line creels with enough spindles so that each end-running has a reserve yarn package placed beside of it. The tail end of the running package is tied to the beginning end of the reserve package. Once the running package is depleted, the yarn transfers over to the reserve package and the warper continues to run. This is a random method of creeling yarn packages compared to block creeling normally used on traveling package creels.



Figure 4.1: Magazine Creels



Direct Warping

Direct warping maintains the yarns in an open sheet form and winds the yarns parallel to each other onto a slightly wider flanged beam. These yarns will not go through the rope indigo dye range, but are left “natural” and will end up either slasher dyed or in an un-dyed fabric, which can later be piece dyed, garment dyed, or left natural. Another option would be to beam dye the yarns using a dye other than indigo.

Direct warping process flow chart

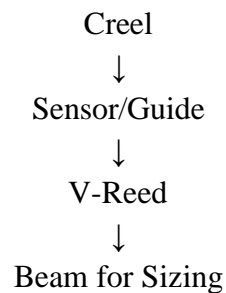

Yarn Suppliers

Amazing Fashions spinning, Salak spinning, Gulsan spinning, Jaber spinning, Noman spinning, Yasmin spinning, Badsha spinning etc.

Package Length

- 6 to 10 Ne required 44800 m & used 44000 m.
- 12 to 16 Ne required 66800 m & used 66000 m.
- 20 to 40 Ne required 88800 m & used 88000 m.

Time Study

- Creel loading time: 80 min (approx.)
- Creel unloading time: 20 min (approx.)



- Getting yarn from store: 5 min
- Machine run time: 24 hours.

Direct warping machine parts name

- Motor
- Monitor
- Bobbin
- Creel
- Guide bar
- Stop motion

Direct warping machine parts name

- If the knot is poor.
- If the yarn is loose.
- If the yarn is broken.
- If the yarn has snarl.

Ball Warping

The main object of ball warping is to prepare log for the rope dyeing machine. Here magazine type of creels is used for the creeling of yarns in the form of cheese. The no. of ends taken one as per requirement of further processes that is for preparing the weavers beam. According to no. of ends in each group, the respective creeling is done to make the required no. of logs to be used at the creeling zone of rope dyeing machine.

Length of rope on log is generally 12830 m, the sheet of yarns passes through the lease reed where lease are inserted, these facilities denting the long the chain beaming. Lease are inserted at regular intervals which can set automatically on the machine. Generally after every 100mts, lease is inserted. Lease also help in yarn separation after sizing.

Ball warping process flow chart

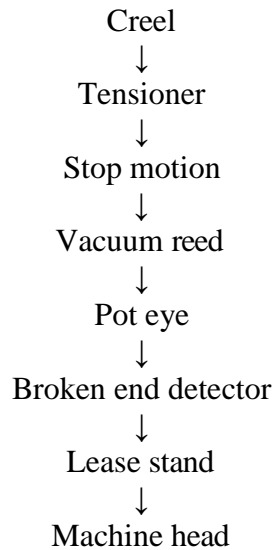

Yarn supplier

- Amazing Fashions spinning, Salak spinning, Gulsan spinning, Jaber spinning, Noman spinning, Yasmin spinning, Badsha spinning.
- Shafyer spinning Pakistan.
- Spintex spinning India.
- Lacra from Thailand.

Time Study

- Ball load: 20min
- Ball unload: 2 min
- Getting yarn from store: 30 min.
- Machine run time: 24 hours

Fault of Ball Warping

Spinning faults

1. Weak places
2. Soft end
3. Slub
4. Weak piecing

Packing fault

1. Bad winding
2. Slough off
3. Extra yarn
4. Cut yarn
5. Entanglement

Long chain beamer (LCB)

Long chain beamer: After the rope dyeing of warp yarn in Amazing production, the next operation is the Long Chain Beamer (LCB). When the rope has been dyed and dried in the rope dyeing range, it is taken in large cans in coiler section. In rope dyeing range, if the machine has a capacity 40 ropes, then there will be 40 separate coilers which delivers 40 ropes in separate cans. These cans are transferred to the Long Chain

Beaming area. The basic purpose of long chain beamer is to open the rope into a sheet form of yarn and wind onto a warper beam which in turn transferred to the sizing machine.

In Long Chain Beamer, the yarn alignment in the dyed rope is change from a rope form to a sheet form. In the Long Chain Beamer the rope pull from the can by moving them upward to a

Process Flowchart For Long Chain Beamer :

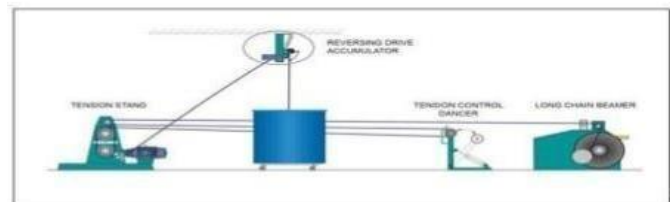
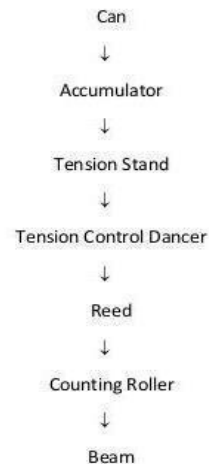



guiding device. The guiding device is mounted above the can, probably in the ceiling. The upward movement of the rope allows the ropes to untangle before nearing the beamer head and allow the rope to shake loose from the rest of the rope in the can.

Time Study

Beam load time: 20 min.

Beam unload time: 5 min.

Getting yarn from store: 10 min. Manpower per machine: 1

Average production/ shift: 30000/35000m.

Lcb important parts

- LCB machine Headstock – monitor, reed, paddle switch, counting roller, neumatic break, dancer, strummer, fan, safety stand etc.
- LCB machine transport-tension roller, open roller, tension break class, I-card, accumulator roller

LCB Problems

- If the yarn knot quality is poor.
- Loose yarn came from ball warping.
- If the yarn is cut or broken.



Part-2(dyeing & sizing)

Dyeing

Slasher / Sheet Dyeing:

In continuous slasher / sheet dyeing and sizing machine, direct warping beams are used, instead of ball warping logs in case of Indigo rope dyeing system. The Slasher Dyeing machine is capable of handling Ne count from 9/s to 30/s (OE and Slub both). At the back end of the slasher / sheet dyeing range, the direct warping beams are creeled. The yarns sheet from each beam is pulled over and combined with the yarns from the other beams so that multiple sheets of yarns can be made.

Creeling of direct warping beam in Sheet dyeing machine

In sheet dyeing range, the total No of required ends for a weavers beam are dyed, dried, sized and dried simultaneously. The back direct warping beam contains 380- 420 ends, similar to rope, but the ends are distributed evenly over the width of the flanges and the end lay parallel to each other.

This continuous slasher dyeing range eliminates a few intermediate processes of the rope dyeing, such as re-beaming, sizing. The yarn sheet from the back beam passes through wash boxes, where it is treated with caustic and subsequently washed with normal water. After squeezing the excess water; the yarn sheet passes through Dye baths and skied for oxidation as in the case of rope dyeing. This develops the indigo coating on the yarn. After dyeing, the dyed yarn is washed by passing through 3-4 wash boxes and finally squeezed before allowing it to pass through drying cylinders. The dyed yarn then enters into the sow box, where it is sized. Subsequently the yarn sheet is dried.

The yarn sheets then passes through a set of stainless steel split rods, which separate them into individual sheets, equivalent to the number of section beams in the creel. After passing through the split rods, the yarn sheets are collected into single sheet and passed through a expansion



comb at the head stock, which separate individual yarns. The expansion comb can be adjusted to the desired loom beam width. Slasher dyeing range typically consists of 1-2 wetting vats, 4- 8 dye baths and 3-4 rinsing troughs. The immersion and oxidation times lie between 10-20s or 45-60s.

The passage of flow of yarns in slasher dyeing is shown below

Pretreatment



Washing



Dyeing



Washing



Drying



Sizing



Drying

Pre Treatment

Pre-treatment process in sheet dyeing consists of treatment of the cotton yarn sheet with caustic and wetting agent. Pre-wetting is carried out in order to get proper dyeing of the sheet. Pre-wetting is carried out with a Wetting agent, at room temperature. In some cases, if well penetration of the dye is required, the yarns are treated with strong caustic soda solution followed by hot wash and cold wash treatment prior to dyeing. The pH of the bath is 11.8-12

Washing

Cold washing is carried out at room temperature.



Dyeing (Indigo blue dye):

The dyeing is carried out in 4 to 8 dye boxes. The dyeing is carried out with; Indigo powder

Sodium hydrosulphite Caustic soda

Dispersing agent

Typical dipping time of sheet in each tank is 15secs and oxidation time is about 90secs.

Washing

The dyed yarn sheet is subsequently in order to remove the unfix dye from the yarn surface.

However the number of washing tank may vary. Typical wash type is: cold wash at room temperature and hot wash at temperature of 70°C.

Drying

The dyed yarn sheet is dried by passing it through drying hot cylinders.

Accumulator

The function of accumulator is to store the extra yarn sheet when the machine is stopped or at the time of size beam doffing, so the dyeing cannot be stop.

4.4.8 Sizing

The yarns are sized in order to achieve the required strength.

Drying

The dyed sheet is dried by passing through drying cylinders.

Advantages of Slasher / Sheet Dyeing:

Slasher dyeing ranges have a number of advantages. Slasher dyeing range produce sized beam directly which is ready to use in weaving. Sheet Dyeing method has the following advantages:

- Slasher dyeing is more comfortable for producing lightweight Amazings.



- These machines require less floor space,
- Enable smaller production runs,
- Have a quicker turn over time,
- The technology is less capital intensive and the machinery cost is less;
- The cost of production is less
- Other type of dye can be used to dye the cotton in this range. Hence the slasher dyeing technique can produce a wide variety of colors other than indigo blue.
- Rope opening is avoided, as in the case of rope dyeing.
- The immersion and oxidation times are much shorter than rope dyeing.

Advantages

- In Sheet dyeing, there is a problem of center to selvedge shade variation.
- The hydrosulphite consumption is much higher owing to the greater surface

Color Dyeing Arrangement

- IBST
- SBIT
- Pure Indigo.
- Grey Black
- Sandwich
- black

Indigo dye recipe:

Indigo 100 gpl



Sodium hydrosulphide	85 gpl
Caustic Soda	70 gpl
Primasol NF	4 gpl
Benquest c-80F	4 gpl

Sulpher Dye Recipe

Sulpher liquid black	50 gpl
R.A Sulpher	28 gpl
Caustic soda	30 gpl
Kiralon EH	7 gpl
Benquest C80F	6 gpl

Dyeing Fault

- Shade variation
- Count mixing
- Color spot
- Stop mark
- Steam high or low
- Lapper
- Size chemical high or low
- Load of shell tension



- Creel tension

Rope Dyeing

Rope Dyeing Machine: Rope Dyeing Machine forms an essential process in the Amazing plant. It works on the principle of the form of rope (from the ball warping m/c). In MIL, 40 ropes are simultaneously fed to the rope dyeing machine through various guides and tensioning arrangement at the creel zone to introduce firstly into the scouring box. The level of this bath is controlled by a leveler which on lowering up to a certain level (manually present) along with liquid level opens a valve for addition of the caustic liquor from the main tank. Then come the two wash boxes, hot wash box followed by the cold one.

The ropes now ready to dye enters the first dye bath. There are eight dye baths and number of them employed depends according to the type of dye to be done. The addition of dye liquor and other aux are carried out through different metering pumps like DYSTAR. The liquors circulated between the employed dyes baths to another circulated pumps, as they are inter connected

.Formula use for estimating the feeding rate:

Feeding (lt/min)=(total no. of ends *machine speed*shade%) (Count *length of yarn)

After coming out of the each dye box yarns are padded, the pressure being highest at the first and last dye box, which is 55psi and the intermediate 40-50psi. The ropes pass after padding around a no. of sky roller to provide adequate time of oxidation. After this the ropes passes through the five wash box, where hot wash, cold wash and neutralization is carried out.

Sometime softener treatment is also given in one of the wash box. The temperature of the entire wash box is controlled through the control panel by means of thermostat.

There are three columns of the vertical drying cylinders range each having twelve cylinder following washing. Each column is providing with the steam trap. The temperature is control from the electronic control panel. The ropes are guided out of the m/c the respective guides, delivery rollers and the guide pipes which coils the ropes in the large can.



Figure 4.2: Rope Dyeing

The passage of yarn in rope dyeing is as follows:

Pre-scouring



Hot wash



Cold wash



Dye baths



Hot wash



Cold wash



Application of softener

Color Dyeing Arrangement

- IBST
- SBIT
- Pure Indigo.
- Grey Black
- Sandwich
- black

Recipe Calculation

Indigo:

Indigo	486 gpl
Sodium hydrosulphide	83.33 gpl
Caustic Soda	400-500 gpl
Primasol NF	15 gpl
Benquest c-80F	15 gpl

Dyeing Result

- Shade variation
- Count mixing



- Color spot
- Stop mark
- Steam high or low
- Lapper
- Cut ends
- Rope crossing
- Rope mixing

Machine Problem

- Dancer problem
- Drive motor problem
- Broken beaming
- PT-100 valve problem
- Dosing pump problem
- Moisture sensor problem
- Uneven sizing pressure

Sizing

Sizing: Size is a gelatinous film forming substance in solution or dispersion form, applied normally to warp yarns. It can sometimes be applied to weft yarns. Sizing is the process of applying the size material on yarn. A generic term for compounds that are applied to warp yarn to bind the fiber together and stiffen the yarn to provide abrasion resistance during weaving. Starch, gelatin, oil, wax, and manufactured polymers such as polyvinyl alcohol, polystyrene,

polyacrylic acid, and polyacetates are employed. The process of applying sizing compounds. The process of weighing sample lengths of yarn to determine the count.

Objectives of Sizing

1. To protect the yarn from abrasion
2. To improve the breaking strength of the yarn
3. To increase smoothness of yarn
4. To increase yarn elasticity
5. To decrease hairiness
6. To decrease the generation of static electricity



Figure 4.3: Yarn Sizing



Types of Sizing

1. **Pure sizing:** when the size pick up % is about 3 – 10 % it is called pure sizing.
2. **Light sizing:** when the size pick up % is about 11 -16% it is called light sizing.
3. **Medium sizing:** when the size pick up % is about 17 – 40 % it is called medium sizing.
4. **Heavy sizing:** when the size pick up % is above 40 % then it is called heavy sizing.

Disadvantages of Sizing

- Cost of land and machine is high
- Requires lot of labors
- Requires utility like gas, electricity etc. and their cost is high
- Cost of ingredients
- The process is long and it takes time
- There is a risk of degradation of yarn
- The yarn diameter is increased
- Requires robust loom
- It increases yarn stiffness
- The fabric needs to be desized before use
- Need knowledge and information about the size ingredients
- There is a risk of pollution
- Sizing changes the shade of colored yarn
- 100% size material cannot be removed



- Size material presence leads to uneven dyeing

Flow Chart for Sizing of Warp Yarn:

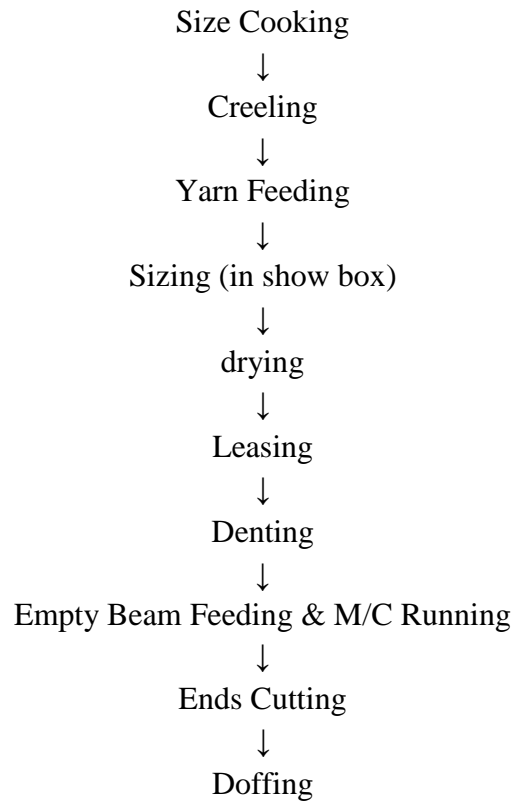

Sizing Chemicals

- Bevaloyed
- Bense B55
- Bense PVA
- Bense P-110
- Bense KU-350
- Bense



- Bevalais_411P
- Bentexo WOX

Sizing Faults Causes

Under slashed Warps:

Causes:

- Due to insufficient size concentration
- Improper size feed to the size box
- Variable size level
- Dilution of size
- Strong squeezing of warp

Over slashed Warps:

Causes:

- Due to insufficient splitting of starch at size preparation
- Weak squeezing
- Too deep immersion of the warp into the size box

Sticky Warps:

Causes:

- High sizing speed
- Low drying temperature



Over Dried Warps:

Causes:

- Low sizing speed
- Long stoppage of machine during sizing
- Very high temperature in the drying section

Gum Spots and Smears:

Causes:

- Splashes of size get on the squeezed warp
- Bad stirring of starch at preparation
- Improper coating of felts on the squeezing rollers

Non Uniform Size Regains:

Causes:

- Irregular heating of the size in the box
- Dilution of the size with live steam
- Non uniform pressure of squeezing rollers

Crossed and Lost Ends:

Causes:

- Lease rods are set too far apart
- Broken ends are improperly pieced up
- Bad warping

Improper Build of Beam:



Causes:

- Incorrect spreading of yarn ends in the reed dents

Incorrect Warp Length:

Causes:

- Disarrangement of the measuring and marking mechanism
- Improper adjustment of measuring and marking mechanism

Dirt Stains in Warp:

Causes:

- The size boxes and machine metal parts are dirty
- The size is cooked in non-galvanized iron kettles.

Shinnery:

Causes:

- Due to the friction between the yarn and drying cylinder

Sandy Warp:

Causes:

- Due to not crushed or grind the size material

Hard Sizing:

Causes:

- Excessive application of size material

Size Dropping:



Causes:

- Due to not optimum viscosity of the size solution

Uneven Sizing:

Causes:

- Due to over and under sizing

Part -3 Weaving

Weaving

The process of producing a fabric by interlacing warp and weft threads is known as weaving. The machine used for weaving is known as weaving machine or loom. Weaving is an art that has been practiced for thousands of years. The earliest application of weaving dates back to the Egyptian civilization. Over the years, both the process as well as the machine has undergone phenomenal changes. As of today, there is a wide range of looms being used, right from the simplest hand loom to the most sophisticated loom. Weaving machines are classified according to their filling insertion mechanism. The classification is as follows:

Classification of Weaving Machine

Weaving machines are classified according to their filling insertion mechanism. The classification is as follows:

1. Shuttle
2. Shuttle-less
 - Projectile
 - Rapier
 - Air-Jet

- Water-Jet

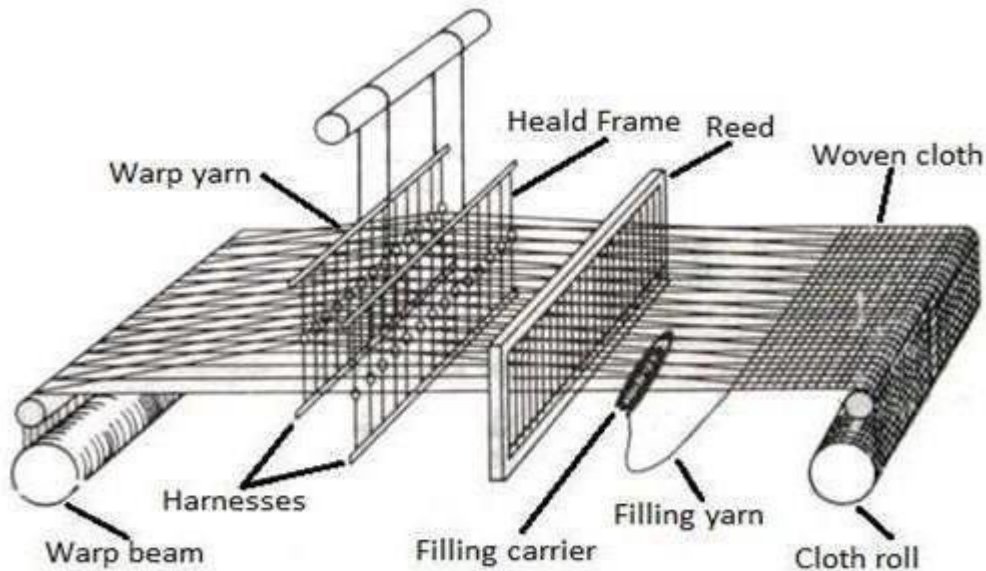

Figure: Basic structure of a loom

Shuttle Weaving

In shuttle weaving, a shuttle that traverses back and forth across the loom width, inserts the filling. Shuttles can be made of wood or plastic. Filling yarn is wound on the quill and the quill is placed in the shuttle. As the shuttle move across the loom, the filling yarn is unwound from the pirn and lay in the shed.

Projectile Weaving

Projectile Weaving use a projectile equipped with a gripper to insert the filling yarn across the machine. The gripper projectile draws the filling yarn into the shed. The Projectile glides through the shed in a rake- shaped guide. Braked in the receiving unit, the Projectile is then conveyed to its original position by a transport device installed under the shed.

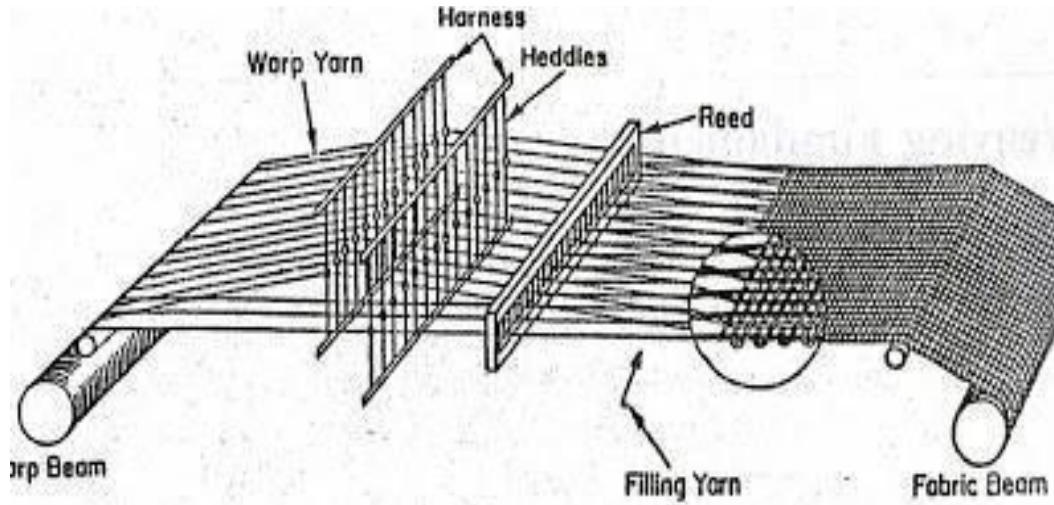

Figure 4.4: Basic Weaving Mechanism

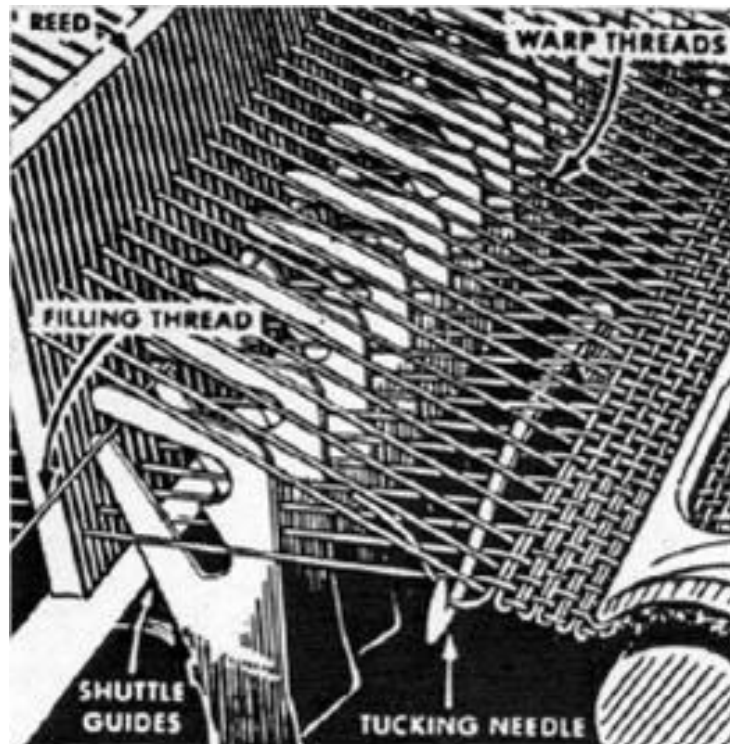

Figure 4.5: Projectile Weaving

Rapier Weaving

In Rapier Weaving, a flexible or rigid solid element, called rapier, is used to insert the filling yarn across the shed. The rapier head picks up the filling yarn and carries it through the shed.

After reaching the destination, the rapier head returns empty to pick up the next filling yarn, which completes the cycle. A rapier performs a reciprocating motion.



Figure 4.6: Weft insertion by rapier

Rapier weaving machines can be of two types:

Single Rapier Machines: A single, rigid rapier is used in these machines. The rigid rapier is a metal or composite bar usually with a circular cross section. The rapier enters the shed from one side, picks up the tip of the filling yarn on the other side and passes it across the loom width while retracting. Therefore, a single rapier carries the yarn in one way only and half of the rapier movement is wasted. Also there is no yarn transfer since there is only one rapier. The single rapier's length is equal to the width of the loom.

Double Rapier Machines: Two rapiers are used in these machines: one rapier, called the giver, takes the filling yarn from the yarn accumulator on one side of the loom, brings it to the center of the machine and transfers it to the second rapier which is called the taker. The taker retards and brings the filling yarn to the other side. Similar to the single rapier machines, only half of the rapier movements are used for filling insertion.

Air Jet Weaving

The Air-Jet Weaving are the weaving machines with the highest weft insertion performance and are considered as the most productive in the manufacturing of light to medium weight fabrics, preferably made of cotton and certain man-made fibers (sheets, shirting fabrics, linings, taffetas and satins in staple yarns of man-made fibers); it has anyway to be pointed out that technically positive results are obtained at present also with heavy weight fabrics (Amazings) and that some manufacturers produce also machine models for terry production. These machines are the ideal solution for those who want to produce bulk quantities of customized fabric styles. The weaving widths range generally from 190 to 400 cm. As regards the multicolor weft carrier, up to 8 different wefts can be fed. It has however to be considered that the air jet weaving machines require a high energy consumption to prepare the compressed air and that this consumption rises definitely with increasing loom width and running speed. The reduction in the energy consumption is in fact one of the main concerns of the manufacturers, and builds for the user an important selection criterion.

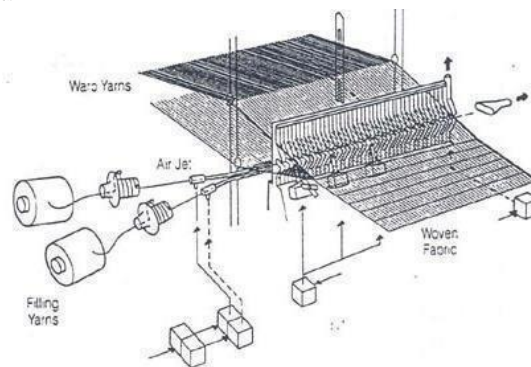
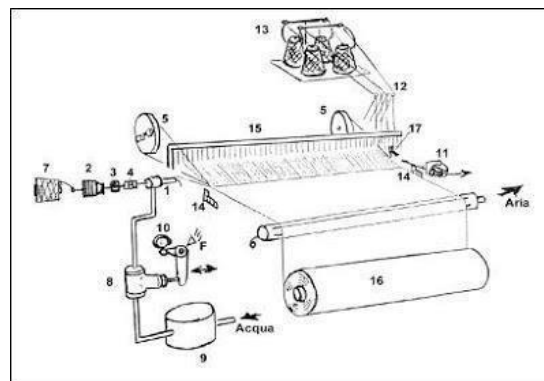

Figure 4.7: Air Jet Weaving

Water Jet Weaving

A Water-Jet Weaving inserts the filling yarn by highly pressurized water. The relative velocity between the filling yarn and the water jet provides the attractive force. If there is no velocity difference, then there would be no tension on the yarn results in curling and snarling of the yarn. Water-jet weaving machine can only be used for hydrophobic fibers.

Basic Weaving Mechanism

As defined earlier, the weaving process requires interlacing of warp and weft yarns at right angle to each other. In order to interlace these yarns, basic mechanism involves primary and secondary motions. The primary motion includes shedding, picking, and beat-up, whereas the secondary motions are warp let-off and cloth take-up.

Primary Motion

The motions that are compulsory for weaving process are called primary motions. Weaving will not happen if any of these motions are not completed. These motions include shedding, picking, and beat-up. The primary weaving motions are shown in Figure-2.

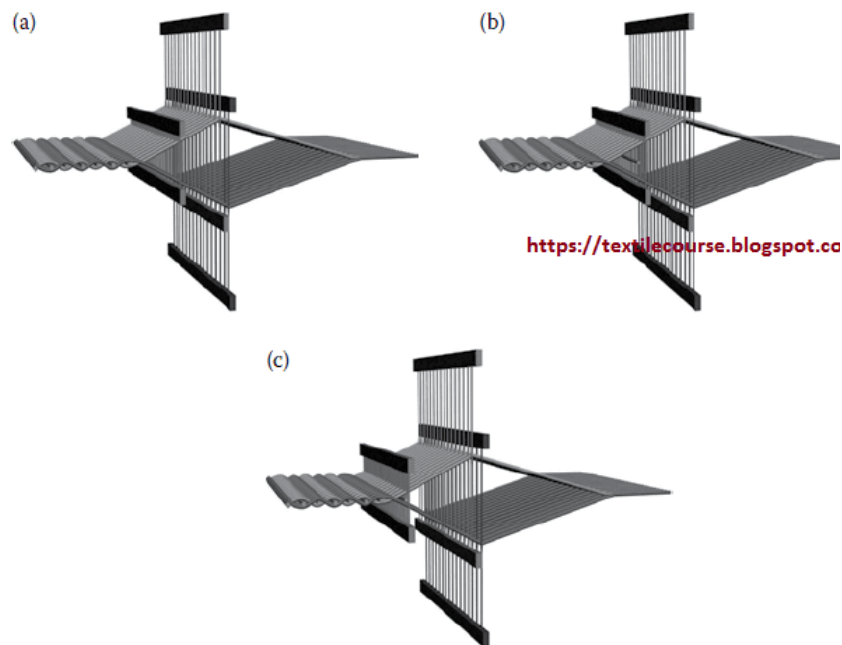

Figure 4.8: Primary weaving motions. (a) Shedding (b) Picking (c) Beat-up.

Shedding:

This is a process of raising and lowering warp yarns by harnesses to make an opening for the filling (weft) yarn to pass through. In shedding motion, warp threads are divided into two layers. The top layer is called top shed line, and the bottom layer is called bottom shed line. The raised and lowered form of warp yarns is called shed, and there are three types of shedding motions available for different types of fabrics, namely tappet shedding, dobby shedding, and jacquard shedding. The shedding is achieved by means of treadles, dobby, or jacquard. The treadles are used in handlooms, operated by the weaver's feet, and in power looms, operated by shedding tappets. The dobby and jacquard are either mechanically controlled or electrically controlled shedding systems. Healds are used in tappet and dobby shedding systems, whereas jacquard controls the warp threads individually for producing sheds by means of hooks, needles, harness cord, and knives. A simple shedding motion controlled by harness is shown in Figure-4.9. On the basis of shed geometry, the shedding is broadly divided into two classes: closed shedding and open shedding.

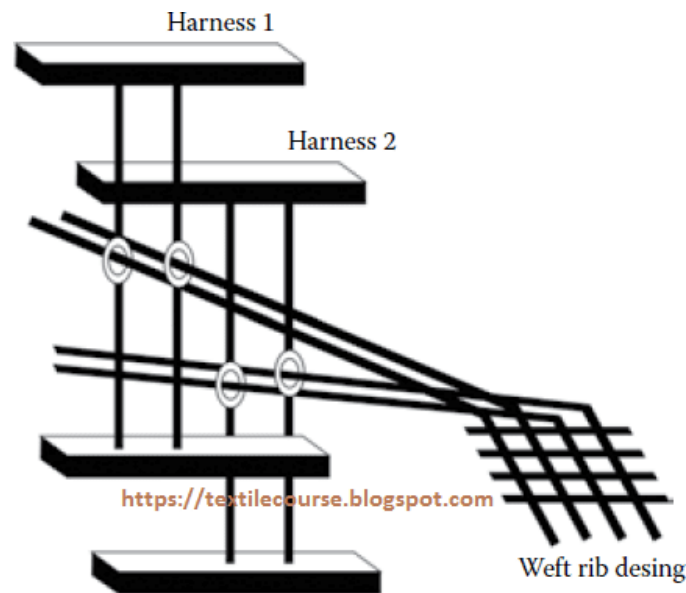

Figure 4.9: Shedding motion

Closed shedding:

The closed shedding system employs all of the warp yarn levels after the insertion of each pick. The level is made either at bottom/top or at the center of shed line. The type of closed shed where the level of warp yarns is made at bottom/top shed line is called bottom closed shed or top closed shed depending on the position of leveling. This kind of shed is produced by giving motion only to threads that are to form the upper shed line. Similarly, the type of shed where warp yarns are made level at the center shed line is called center closed shed. In center closed shed, the warp yarns required to make the top shed line are made to move upward, whereas the warp yarns required to make the bottom shed line are made to move downward. Afterward, all the warp yarns meet at the center shed line. The schematic diagrams of bottom closed shed and center closed shed are shown in Figure-4. The advantage of bottom closed shed is to achieve high cover factor at the cost of high power consumption and wear and tear of weaving parts. The bottom/top closed shed is not suitable for high-speed weaving due to larger time required for changing the shed. The high-speed weaving can be achieved by center closed shed due to less strain in warp yarns as compared to bottom/top closed shed. The power consumption and wear and tear are also less in center closed shed as compared to bottom/top closed shed.

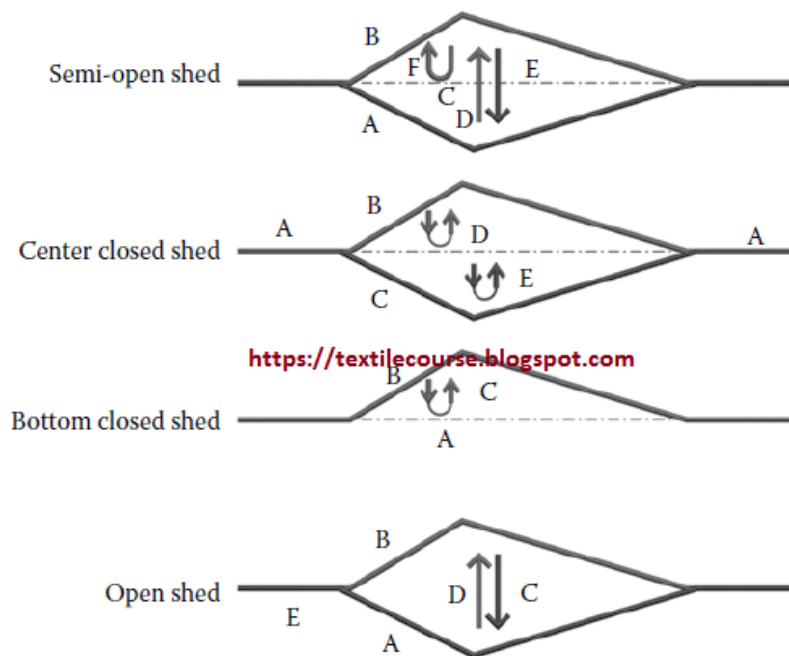

Figure 4.10: Semi-open, center closed, bottom closed, and open shed.

Open shedding:

In open shedding, the warp is only moved when a pattern requires a change of position. There are two methods of producing open shedding, that is, open shedding and semi-open shedding. In semi-open shedding, as shown in Figure-4, the stationary bottom line is retained, but warp yarns of the top shed line is either lowered to the bottom at one movement or raised to the top. The remaining warp yarns move down. This is formed under both open and closed principles and is being used by double-lift dobby and Jacquard shedding system.

In open type of shedding, as shown in Figure-4, the warp threads form two stationary lines, one at the top and the other at the bottom. After inserting a pick, threads are moved from one fixed line to the other. So, one line of thread is lowered from the top to the bottom, and the other line was raised from the bottom to the top simultaneously. Open shedding is performed using ordinary tappets.

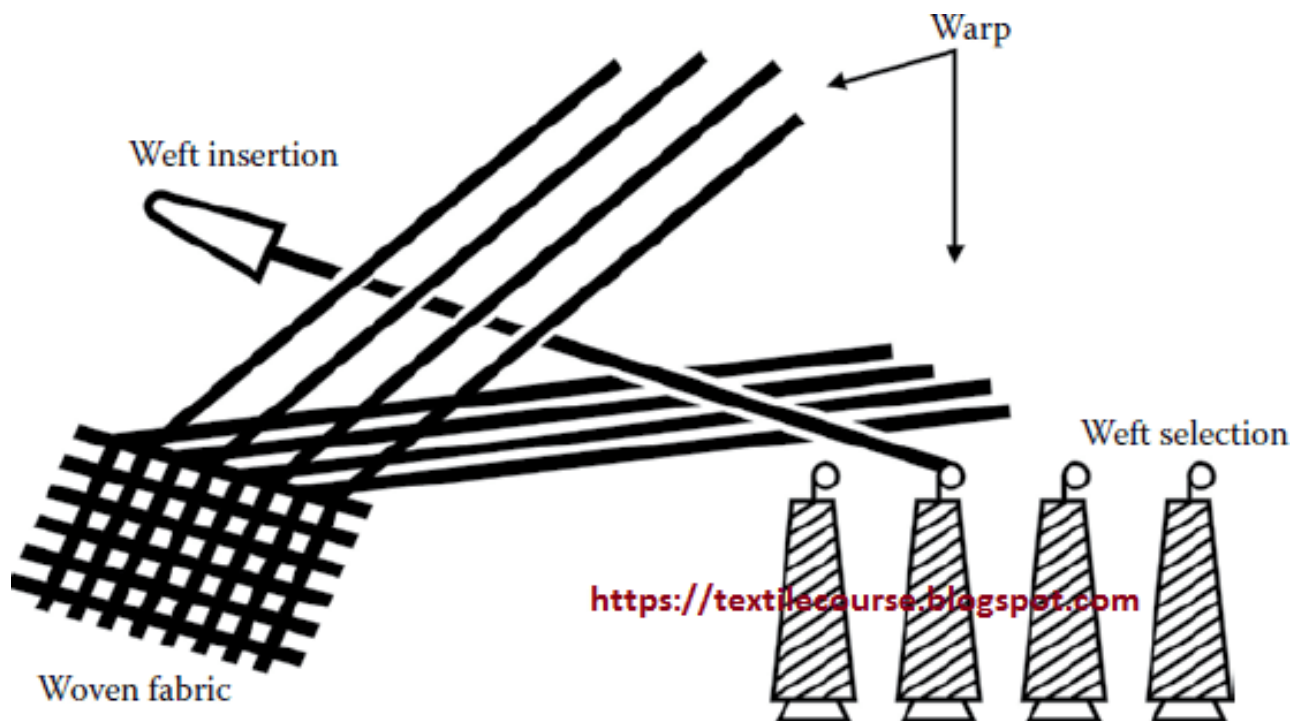

Figure 4.11: Picking

Picking:

The insertion of weft yarn through shed is called picking. Mostly, the weaving machines are categorized based on their picking systems. There are two major types of available picking systems, namely shuttle and shuttle less picking. Shuttle picking is further categorized into two main systems, that is, under picking and over picking. In under picking, the picking stick moves under the shuttle box, whereas in over picking, the picking stick moves over the shuttle box.

In shuttle less picking system, the picking is carried out with the help of various picking media such as projectile, rapier, air, and water. Shuttle less picking system has an advantage of high speed over shuttle picking system. A number of weft (filling) selections are made available on weaving loom to select the desired weft depending on the count and color of weft yarn. A weft, being inserted through a shed, is shown in Figure 4.11.

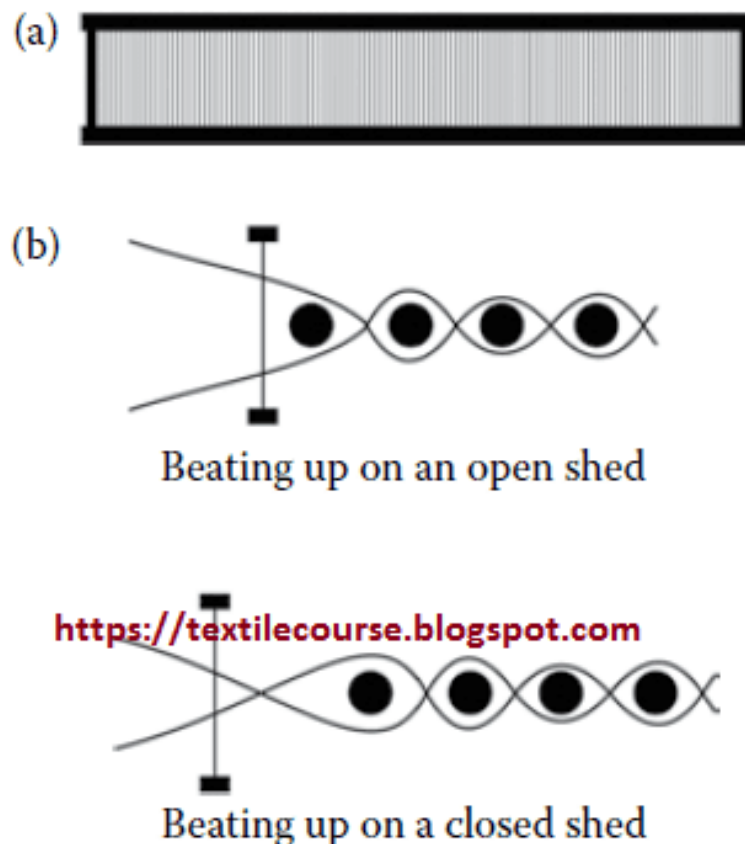

Figure 4.12: (a) A reed used for beat-up, (b) beat-up for an open and closed shed

Beat-Up:

The filling insertion system cannot fit the weft at an acute angle of shed opening, which is done with the help of beat-up motion. The fitting of newly inserted pick to the fell of cloth is called beat-up. The fell of cloth is an imaginary line which shows the point of cloth woven. The beat-up is performed with the help of a device called reed. The reed acts like a comb made of metal stripes. A typical reed is shown in Figure 4.12.

Secondary Motion

The weaving motions required to make the weaving process continuous are called secondary motions. These motions include warp let-off motion and cloth take-up motions.

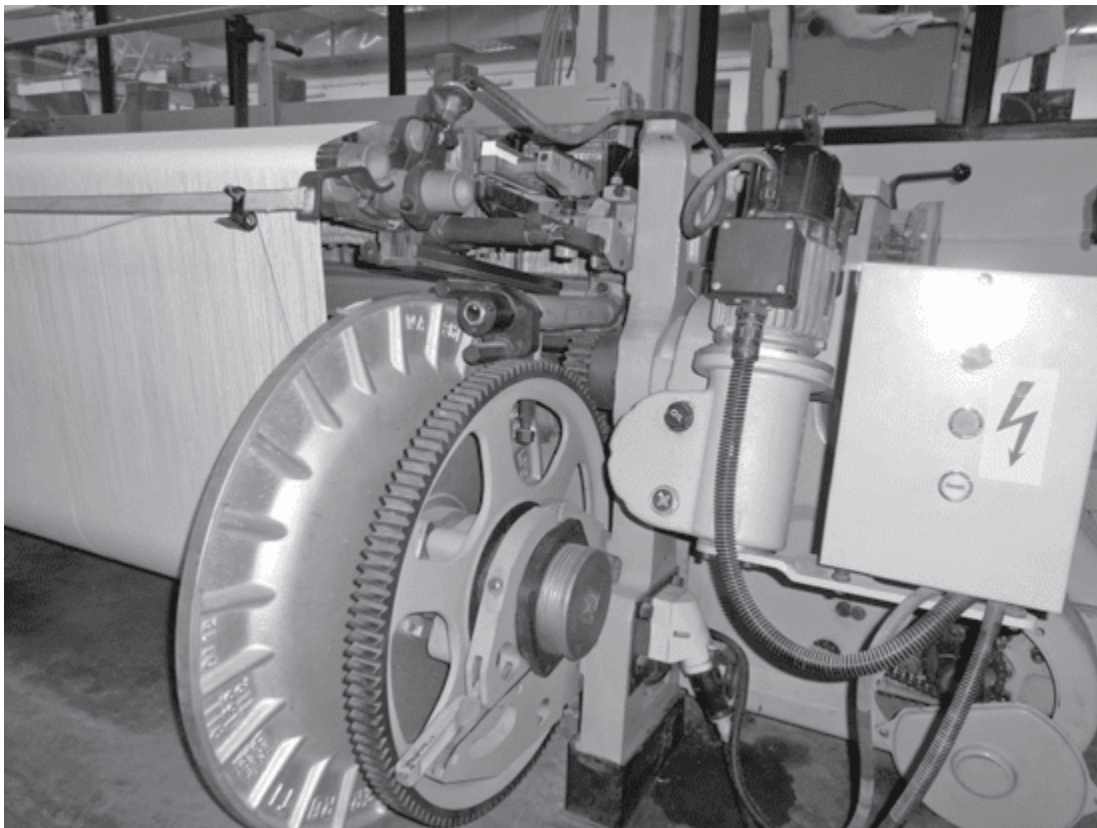

Figure 4.13: Let-off mechanism on loom.



Warp let-off motion:

As the fabric is produced, it is required to let off the warp yarn for continuous weaving. The delivery of warp yarn at required speed is called warp let-off motion. The warp yarns are delivered in the form of sheet from weaver beam installed at the back of loom. The let-off motion has been controlled by dead weight called lingos, but nowadays the speed of this motion is controlled using load cell and servo motor. An electrically controlled warp let-off motion is shown in Figure-7. As the cloth is woven, the warp yarns exert a tension on whip roller. The whip roller moves forward toward the front side of loom and does an amount of work against the force of spring. The work done in terms of displacement is measured by a sensor, which gives signal to control panel. The control panel sends instruction to servo motor to adjust the speed in order to let off the warp sheet.

Cloth take-up:

The woven cloth needs to be wound on a specific package after it has been beaten up. The winding of woven cloth is called take-up. The cloth is wound on a roller, which is placed on the front side of loom, called the take-up roller. The take-up motion defines the pick density of woven cloth. It is important to note here that take-up of cloth is always less than the length of warp sheet due to warp shrinkage. Modern cloth take-up systems are electrically controlled by servomotor as shown in Figure-8. The take-up roller is connected to servo motors via pairs of worm and worm wheel. The take-up system is equipped with electrical sensor to control the surface speed of take-up roller to provide the required number of picks per unit length.

Auxiliary Motion

These mechanisms are useful to produce defect-free woven fabric production. Weaving machine is the complex machine. It is difficult to monitor all the points like yarn breaks, finish of weft yarn, etc. Without these tertiary motions, the process will continue, but it is quite impossible to make a defect-free cloth. Hundreds of yarns are running in a loom, so it is quite impossible to monitor all the yarns separately. It may cause the faulty production.



Figure 4.14: Take-up mechanism on loom.

Warp stop motion:

Warp stop motion stops the loom at the event of warp yarn breakage. The motion helps to remove the faults which are expected to be produced due to warp yarn breakage. All the warp yarns are required to pass through an individual special inclined shape wire, which is called dropper. The length of dropper ranges from 120 to 180 mm, while the width of dropper is usually found as 11 mm. In the event of warp breakage, the dropper wire falls on dropper rod. The dropper rod is composed of positive and negative terminals. After the falling of dropper wire, the electrical circuit of the dropper rod is completed. The completion of electrical circuit sends the instruction to servo motor to stop via control panel.



Weft stop motion:

Weft stop motion has been used to stop the loom at the event of weft breakage. In modern looms, mainly two types of weft stop motions are used, namely piezoelectric electronic weft stop sensor and optical sensors. The optical type of weft stop sensors is shown in Figure-9. The piezoelectric weft stop sensor is designed for rapier and projectile looms, whereas the optical sensors are made especially for air-jet looms. The piezoelectric sensor is made of smart materials, which works on the principle that vibration produces electric charges. The electric charges produced are used to send the signal to stop loom. Under normal running of loom, the electric charges are produced with low amplitude due to less vibration; however, when the weft yarn is broken, a jerk is produced which results in high amplitude of electric charges. These high-amplitude electric charges are used to stop the loom. On the other hand, the optical sensor detects the light emitted by a light source. In air-jet looms, optical weft stop motion sensor serves two purposes, that is, stops the loom if weft yarn is broken and stops the loom if weft yarn has been moved too forward. The sensors are classified as Weft Feeler 1 and Weft Feeler

2. Weft Feeler 1 senses the absence of weft yarn and stops the loom, whereas Weft Feeler 2 senses the presence of yarn and stops the loom.

Other auxiliary motions are warp tension compensation motion, weft tension control motion, auto pick finding motion, weft mixing motion, weft holding, tucking and trimming motion, warp protector motion, weft replenishment motion, and temple motion.

Amazing Fashions Weaving

There are total 4 weaving section in Amazing Fashions

ltd. In slasher Amazing 144 looms. In rope Amazing

223 looms. Section -4

Total loom-69

PICANOL OMNI plus Summum air jet loom-25 looms. PICANOL Optimax-I rapier loom-24 looms.

PICANOL Optimax rapier loom-20 looms.

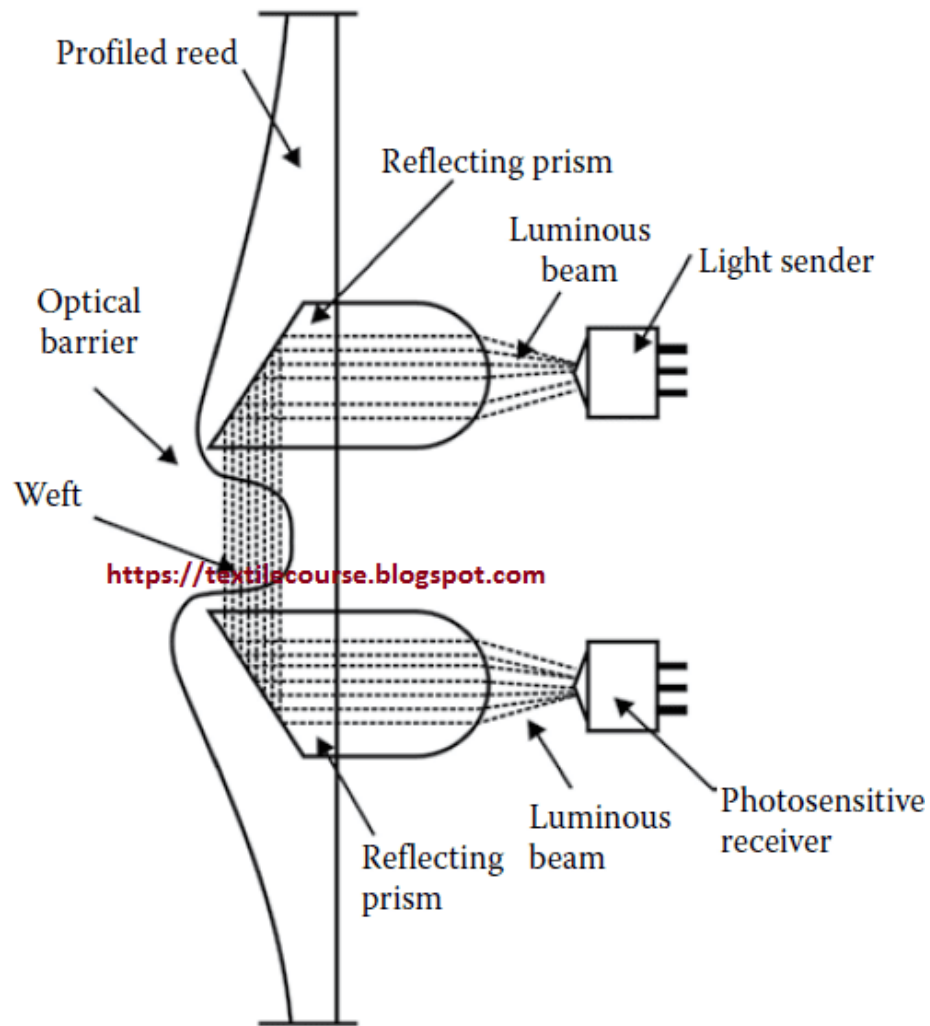

Figure 4.15: Optical weft stop sensor.

Weaving Design

- 3/1 RHT
- 3/2 RHT
- 2/1 LHT
- 3/1 LHT



- 2/2 LHT
- 3/1 BROKEN TWILL
- 2/1 SATIN

Weft Count

- Open end- 8,10,16 Ne
- 16L-70D
- 16L-40D
- Ring – 20, 30 Ne
- 150DPL-70D
- 300DPL-40D
- 300 DP
- 600D

Wastages

- Fabric
- Yarn
- Polyethylene
- Cone
- Selvedge
- Wastage
- Chute

Various Types Reed Used

- 588/590 d/m.



- 652 d/m.
- 698 d/m.
- 780 d/m.
- 827 d/m.
- 869 d/m.
- 931 d/m.
- 1085 d/m.
- 1102 d/m.

Cam Setting

2/1, 1/2, 1/1, 3/1, 1/3, 4/1, 1/4.

Weaving Faults

- Colored flecks
- Knots
- Slub
- Broken ends woven in a bunch
- Broken pattern
- Double end
- Float
- Gout
- Hole, cut, or tear
- Lashing-In
- Local distortion



- Missing ends
- Missing Pick
- Oil and other stain
- Oily ends
- Oily picks
- Reed mark
- Slough of
- Shuttle smash
- Snarls
- Stitches
- Untrimmed loose threads
- Weft bar

Selvages

ELSY- 3/1, 4/1, 2/1, 1/1, 2/2.

Machine Parts Name

Air jet loom

1. Motors –

- Sumo motor.
- ETU
- ELO
- WCM(wastage cutter motor)
- Filling cutter



- Eleno-2
- ELSY-2
- ELCA-8
- Pre-winder
- PFT-2
- EPR-6
- Batcher
- Leveling motor.
- 2. Batcher roller
- 3. Reed
- 4. Slay sword
- 5. FD-1
- 6. FD-2
- 7. Finger
- 8. Wheel
- 9. Gripper receiver belt
- 10. Monitor
- 11. Take up roller
- 12. Pressure roller
- 13. Batcher roller
- 14. Valve
- 15. Air treatment plant.
- 16. Warning lamp
- 17. Catch cord bobbin
- 18. Yarn guide



19. Yarn guide roller

20. Ring frame

21. Panel board

22. Heald frame-6

23. Cam box

24. Cam

25. Overhead cleaner

26. Pre-winder

27. Filling cutter

28. Wastage cutter

29. Creel stand

30. Nozzle-

- Relay nozzle
- Movable nozzle
- Fixed nozzle.

Optimax:

1. Motors –

- Sumo motor.
- ETU
- ELO
- WCM(wastage cutter motor)-2
- Filling cutter
- EDC motor
- ELSY-2
- Pre-winder-2



- Batcher
 - Leveling motor.
 - Oil pump
 - Suction motor
 - Cooling motor
2. Batcher roller
 3. Reed
 4. Slay sword
 5. FD
 6. Finger
 7. Wheel
 8. Gripper receiver belt
 9. Monitor
 10. Take up roller
 11. Pressure roller
 12. Batcher roller
 13. Warning lamp
 14. Catch cord bobbin
 15. Yarn guide
 16. Yarn guide roller
 17. Ring frame
 18. Panel board
 19. Heald frame-12
 20. Overhead cleaner



21. Pre-winder
22. Filling cutter
23. Wastage cutter
24. Creel stand
25. Temple
26. Yarn guide
27. Contact bar
28. Leno bobbin.
29. Opener
30. Creel stand
31. Dobby



Part 4

Finishing

Finishing

Finishing is the last and critical process of Amazing manufacturing where final touch is given to the fabric to ensure the quality parameters (such as PPI, Shrinkage%, Moisture%, Bow & Skew) and to increase attractiveness. Finishing process is done in order to impart the required functional properties to the fabric by different physical and chemical treatments.

Benefits of Finishing

- To improve attractiveness of the fabric.
- To increase the life time or durability of the fabric.
- To meet up specific requirement of the fabric for achieve the final goal.



- To improved smoothness & feel of the fabric
- To increase weight of the fabric.
- To improved wearing qualities of fabric by controlling shrink resistance, creaseresistance, skew, bow etc

Above all

- To cover all the fabric parameters after garments.

Classification of Finishing

Textile finishes are classified in different ways. The most classifications are:

Aesthetic finishes: This type of finishes make change or modify the appearance of the fabric or hand/drape properties of the fabrics.

Functional finishes: This type of finishes changes the internal performance properties of the fabric.

Finishes also classifies as follows:

Mechanical finishes: This type of finishes also called as dry finishes. This type of finishes involves specific physical treatment to a fabric surface to cause a change in fabric appearance.

Chemical finishes/Wet finishes: This type of finishes usually applied to fabric by padding followed by curing or drying.

Finishes also can be classified by their degree of performance as follows:

Permanent finishes: It involves a chemical change in fiber structure and do not change throughout the life of a fabric.

Durable finishes: Usually last throughout the life of a fabric, effectiveness becomes diminished after each cleaning and near the end of normal use life of the fabrics, the finishing is nearly removed.

Semi-durable finishes: Usually last several launderings or dry cleanings and many are removal in home laundering or dry cleaning.

Temporary finishes: Removed or substantially diminished the first time an article is laundered or dry cleaning.

Singeing Machine

Singeing is a process by which projecting or floating fiber out on the surface of the fabric are burned off.

Benefits of Singeing

To remove dust and hairy fiber and increase smoothen & luster of the finished fabric.

Machine Parts of Singeing

- J-box unit
- Brushing unit
- Burner unit
- Beating unit
- Batching unit

Machine parameter

- Machine speed,
- Burner intensity,
- Brushing intensity
- Beating intensity
- Dust collector
- Water spray
- Plain sewing,
- Over lock sewing,



- Sewing thread count

Special Checkpoints

- Naps & Hairiness
- Speed of machine
- Burner intensity
- Cooling line
- Water spray unit
- Input width of fabric
- Construction of fabric

Cleaning Area of Singeing

- Loading box
- Under the j box
- In & out side of brushing unit
- In & out side of burner unit
- All roller of burner unit
- In & out side of beating unit
- Water spray unit

Osthoff Singeing Parameter According to GSM:

GSM	Ounce	M/C Speed	Burner Height/mV	Burner Position	Fabric Temp.
119	3.5	140	14	1	110
136	4	140	14	2	110
153	4.5	150	16	2	110
170	5	130	16	3	110
187	5.5	130	15	3	110
203	6	130	16.5	3	110
220	6.5	110	14.5	3	110
237	7	110/120	14/16	4	110
254	7.5	110	16.5	4	110



271	8	100	15.5	4	110
288	8.5	90	14.5	4	110
305	9	90	15	4	110
322	9.5	90/80	17	4	110
339	10	80	17	4	110
356	10.5	80	15.5	4	110
373	11	80	15.5	4	110
390	11.5	70	15.5	4	110
407	12	70	15.5	4	110
424	12.5	70	15.5	4	110
441	13	70	15	4	110
458	13.5	60	15	4	110
475	14	60	15	4	110
492	14.5	60	15	4	110
509	15	60	18	4	110

Sanforizing Machine

Sanforizing is a mechanical process of treating textile fabrics to prevent the normal dimensional alteration of warp and weft which occur in finishing process specially those carried on in laundering and allied operations

Benefits of Sanforizing

- To prevent shrinkage during washing.
- To increase luster & smoothness of fabric
- To control adequate skew, bow moisture etc.

Machine Parts Sanforizing

- Loading unit
- Chemical box
- Skew unit
- Dryer unit
- Rubber belt unit
- Palmer unit



- Folding unit

Machine Parameters Sanforizing

- Speed
- Guider pressure
- Padder pressure
- Dry cylinder temperature
- Rubber belt temperature
- Moisture
- Palmer temperature
- Cooling Water

Process Parameters of Sanforizing

- Skew
- Bow
- Width
- Warp shrinkage
- PH

Skew: Weft wise angular deformation of the fabric is called skew. The amount of skew depends on the fabric constructions or weave. Such as

3/1 RHT/LHT twill	8.0-10% (Avg)
2/1 RHT/LHT twill	4.0-5.0% (Avg) 3/1
Broken twill	0%
1/1 plain	0%
4/1 Satin	4.0-5.5%

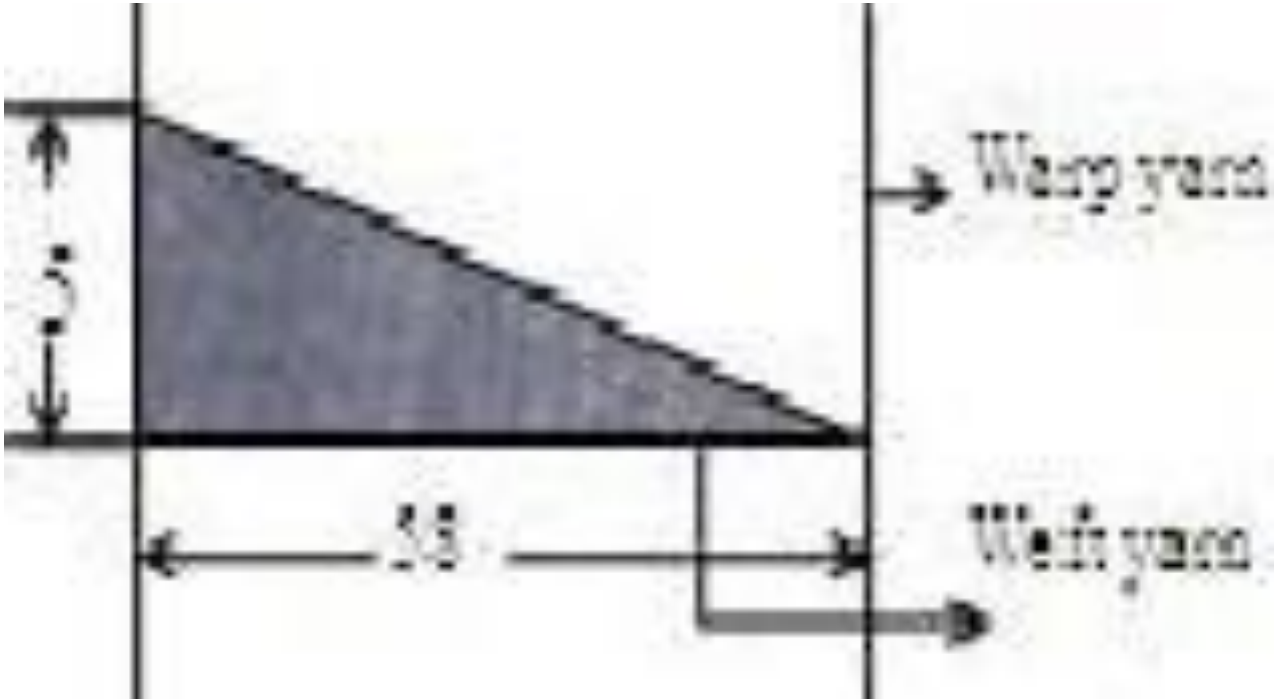

After wash Grey skew:

$$\text{Skew\%} = (\text{Displacement} / \text{width}) * 100$$

$$= (5/58) * 100$$

$$= 8.62\%$$

Calculation:

After wash finish fabric skew% $\text{Skew\%} = \text{A/W skew} - \text{B/W skew}$

$$= 8.62\% - 8.62\%$$

= 0 (It is called movement)

Standard movement = +/- 1.5 %

But now=Standard movement = +/- 0.5%

During finishing we maintain finish fabric skew according to skew of grey fabric. So after finished movement should be zero (0). The quality of fabric falls due to skew problem. So we physically check skew of fabric more & more during finishing.

Bow: The curvy state of weft yarn in the fabric is known as bow. Following fabric show the effect of bow. Fabric bow effect This is standard form of fabric

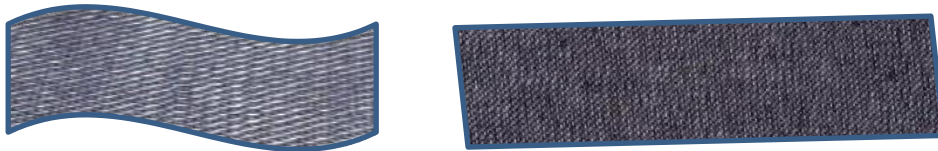

Calculation:

Bow % = (displacement/width)*100 Standard bow (cm) = +/- (2-2.5) cm

So that, bow is the important fabric parameter for quality. For this reason, we check bow more & more during finishing.

Width:

- Width depend variation occur
- Width is another more important fabric parameter. So we physically checked width during finishing.
- Width depends on the pressure of the tension roller or dancer roller.
- When width variation occurs than the requirement width, then we check the dancer pressure.

Warp Shrinkage: Pick means warp shrinkage



Less pick more shrinkage More pick less shrinkage

So pick and warp shrinkage related with each other. As per example, one style 1103x1D have grey pick 50 & warp shrinkage 14.5 % . If after finished pick 57 then warp shrinkage will be

+1 or -1

Warp Shrinkage% = $\{(A/F \text{ Pick} - B/F \text{ Pick}) / \text{Pick B/F}\} * 100$

= $\{(57-50) / 50\} * 100$

= 14 %

So that, warp shrinkage depends on the pick. If pick more or less than the requirements then the fabric come back for refinish. During refinishing width short may be occur. As a result that fabric ahead to non-dispatch or B grade. For this reason we physically checked pick with the help of counting glass frequently.

pH: The pH of a solution is a measure of the molar concentration of hydrogen ions in the solution and as such is a measure of the acidity or basicity of the solution. pH is the negative logarithm of the hydrogen ion activity in a aqueous solution. The letters pH stand for "power of hydrogen" and the numerical value is defined as the negative base 10 logarithm of the molar concentration of hydrogen ions. $\text{pH} = -\log_{10}[\text{H}^+]$

We maintain ph of sanforizing chemical box 2.5 -3.0 and mercerize neutralize box 3.0-4.0.

Chemical recipe of sanforizing:

Softening agent =10 gpl

Wetting agent =4 gpl

Acid = 5 gpl

Stenter Machine

Machine parts of stenter:

- Loading unit
- Chemical box



- Over feed & under feed unit
- Heat chamber unit
- Cooling unit
- Batching unit

Function of Stenter

- Heat setting
- Weft Shrinkage control as per buyer requirements.
- Width control as per buyer requirements.
- Parallel of warp & weft yarn
- Width recover as per necessarily.
- Pigment dyeing(overdyeing)
- Coating Machine specification:
 - Brand : Monforts
 - Origin : China
 - Speed : (10-100) mpm
 - No. of burner 10
 - No. of chamber 10
 - No. of blower 20

Process Parameter of Stenter Machine

- Temperature
- Speed
- Set width
- Padder pressure
- In & out width



De-sizing

Desizing is the first wet processing textile finishing technology employed to remove the sizing material from the fabric.

Benefits of de sizing

- To remove the dyed & sized materials from the fabric.
 - To increase the absorbency & luster of the fabric.
 - To help the perfect action of subsequent process such as mercerization, over dyeing etc.
- Machine specification:

- Brand : Smartech
- Origin : China
- Function : Desize & Over dyeing
- Speed : (5-80) mpm
- Desize box 01
- Over dyeing box 01
- Wash box 08
- Dryer 03

Machine Parts of Desizing

- Loading unit
- Chemical box
- Airing time zone
- Wash box
- Softening box
- Dryer unit
- batching

Process Parameter of De-sizing

- Speed of machine



- Temperature of chemical box
- Temperature of wash box
- Padder pressure
- Dancer pressure
- PH of chemical box
- Dryer temperature
- In & out width

Chemical Recipe of De-sizing

Desizing agent = 7gpl

Wetting agent= 5gpl

Cleaning Area of De-Sizing

- Loading box
- Chemical box
- Wash box
- Sky roller
- All padder & dancer roller
- All drain line
- All water spray
- All dryer cylinder

Mercerizing

Mercerization is a process where fabric is treated with (25-32)° baume caustic soda solution at a temperature of 200-300C. It is necessary to hold the fabric under tension and wash thoroughly.

Benefits of Mercerizing

- To increase the tensile strength, tear strength, luster, & absorbency of the fabric.
- After merceized chemical pick up% comparatively less but shade consistency will be good.



Machine parts of Mercerize

- Loading unit
- Chemical box
- Airing time zone
- Mercerize chain unit
- Wash box
- Softening box
- Dryer unit
- batching

Process Parameter of Mercerize

- Speed of machine
- Temperature of chemical box
- Caustic baume
- Wetting time
- Temperature of wash box
- Temperature of sucking tank
- Padder pressure
- Dancer pressure
- PH of neutralize box
- Dryer temperature
- In & out width

Chemical Recipe of Mercerize

Caustic soda = 25 Baume

Wetting agent = 5gpl



Acid =10gpl

Chemical Area of Mercerize Machine

- Loading box
- Chemical box
- Mercerizing chain unit
- Wash box
- Acid box
- All Sky cylinders
- All padder & dancer roller
- All drain lines
- All water sprays
- All dryer cylinders

Special Care of Mercerize

More Concentration = more Color remove = Shade will be light But, concentration same then

Less m/c Speed= more Color remove = Shade light

Over Dyeing

Main ingredients of over dyeing:

- Dyestuff
- Reducing agent
- Caustic soda
- Wetting agent
- Sequestering agent
- Ladiquest



Bleaching

Bleaching is chemical treatment employed for the removal of natural coloring matter from the substrate. The source of natural color is organic compounds with conjugated double bonds, by doing chemical bleaching the discoloration takes place by the breaking the chromophore, most likely destroying the one or more double bonds within this conjugated system. The material appears whiter after the bleaching.

The aim of bleaching:

- Removal of coloured impurities.
- Removal of the seed coats.
- Minimum tendering of fibre.
- Technically reliable & simple mode of operation.
- Low chemical & energy consumption.
- Increasing the degree of whiteness.

Chemical component for Bleaching:

- NaOH
- H₂O₂
- Stabilizer
- Wetting agent
- Reaction time
- speed

Which factors are responsible for bleaching?

The important parameters for bleaching with hydrogen peroxide are as follows:

- Concentration of hydrogen peroxide.



UGC & Govt. Approved

Sonargaon University (SU)

সোনারগাঁও ইউনিভার্সিটি (এসইউ)

WE WILL
RISE UP
WE WILL
SHINE

- Concentration of alkali.
- pH.
- Temperature.
- Time.
- Nature and quality of the goods.
- Water hardness and other impurities.
- Types and concentration of auxiliaries.
- Desired bleaching effect.
- Available equipment and stabilizer system employed.



UGC & Govt. Approved

Sonargaon University (SU)

সোনারগাঁও ইউনিভার্সিটি (এসইউ)

WE WILL
RISE UP
WE WILL
SHINE

Part 5

Inspection

Inspection

Inspection can be defined as the visual examination or review of raw materials (such as fabric, buttons, zippers, sewing threads, trims etc.), partially finished components of the garments and completely finished garments in relation to some standards, specifications or requirement as well as measuring the garments to check if they meet the required measurements.

Objectives

The main objectives of inspection is the-

1. Detection of Defects
2. Correcting of defect or defective garments as early as possible in the manufacturing process so that time and money are not wasted later.

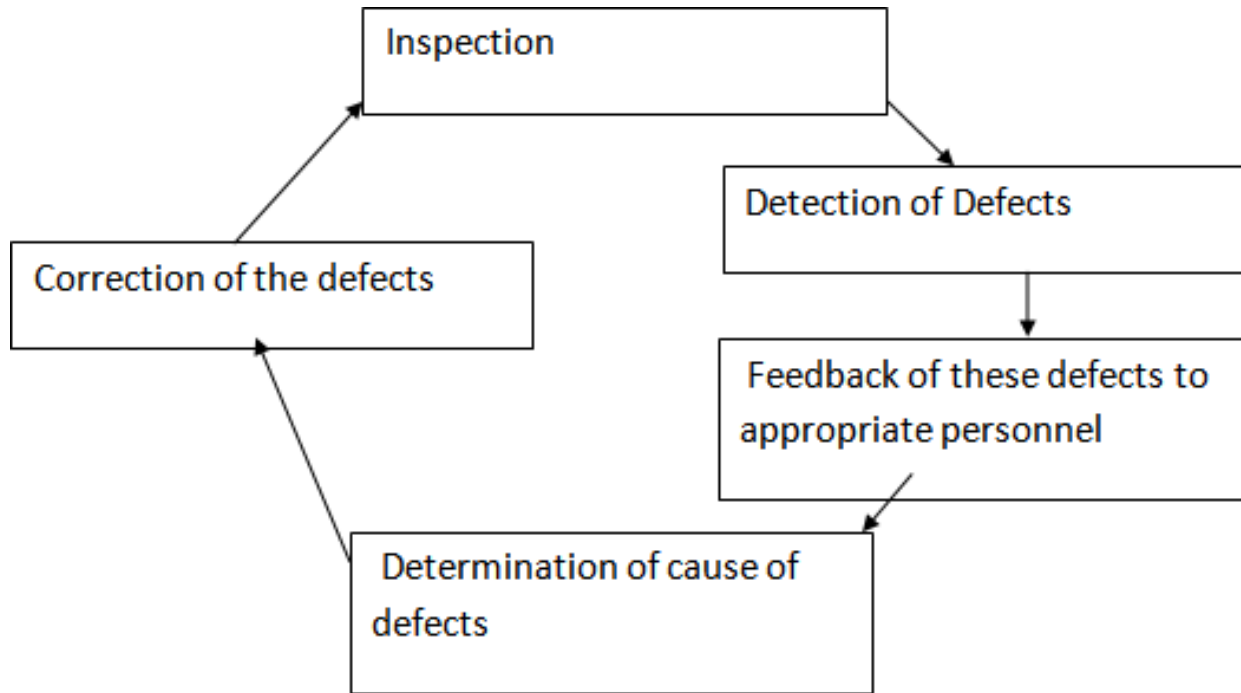

Figure 4.16: Inspection Loop

Fabric Inspection Method

Fabric is inspected to determine its acceptability from a quality view point.

There are various fabric inspection system such as-

- 4- point system
- 10- point system
- 2.5- point system etc.

4-Points System

- The 4- point system is widely used for fabric inspection, in the united states it is known as AAMA point grading system (AAMA- American Apparel manufacturers association).

Procedure of 4-Points System

1. Fabric inspection is usually done on fabric inspection machineries.



2. These machineries are designed so that rolls of fabric can be mounted behind the inspection table under adequate light and re-rolled as they leave the table.
3. Inspection machineries are either power driver or the inspector pulls the fabric over the inspection table.
4. The defects are located, marked and recorded on an inspection form.
5. Some machinery is equipped to measure the length of each roll of fabric (meter/yard).

Fabric defects point values based on the following:

Length of defect in Fabric	Points allotted
Up to 3 inches	1
Over 3 inch up to 6 inches	2
Over 6 inch up to 9 inches	3
Over 9 inches	4
Holes and Opening	
1 or less	2
Over 1 inch	4

Calculations of Result

Total defect points per 100-yard square are calculated.

If fabric rolls contain less than 40 points per 100-yard square are considered “first” quality and as an Acceptance criterion.

If fabric rolls containing more than 40 points per 100 yards square are considered “second”.

List of defects in woven fabric is given bellow:

- Colored flecks
- Knots



- Slub
- Broken ends woven in a bunch
- Broken pattern
- Double end
- Float
- Gout
- Hole, cut, or tear
- Lashing-In
- Local distortion
- Missing ends
- Missing Pick
- Oil and other stain
- Oily ends
- Oily picks
- Reed mark
- Slough of
- Shuttle smash
- Snarls
- Stitches
- Untrimmed loose threads
- Weft bar



Part 6

Testing

Testing

Dimensional Stability Testing Procedure (American Method).

AATCC: 135

Test Name

Dimensional Change of fabrics after Home Laundering.

Apparatus

- 1) Washing machine.
- 2) Drying machine
- 3) Conditioning racks with perforated shelves.
- 4) 1993 AATCC Reference detergent or 2003 AATCC standard Reference detergent.
- 5) Ballast: 920 ×920 mm (type 1 or type 3)
- 6) Indelible ink.
- 7) Template.
- 8) Tape
- 9) Sewing thread

Conditioning

Should be conditioned at least 4 hours as per ASTM D 1776 (Temp: $21 \pm 1^\circ\text{C}$, R.H = $65 \pm 2\%$)

Preparation

Avoid use of the sample area within 10% of the Sample width, Identify the length direction before cutting out of the Sample. Cut three Specimens dimensionally.

Marking

Option-1: Sample size = 380×380 mm Benchmark = 250×250 mm

Distance from the edge = 50 mm



Pairs of benchmarks in the same direction in the direction must be spaced approximately 120 mm apart.

Washing

Weight test Specimens and enough ballast to make a 1.8 ± 0.1 kg (4.00 ± 0.25 lb) load. Fill the washing machine to the 18 ± 0.5 -gal water level. Temperature should be maintained as per care instruction. Add 66 ± 1 g of 1993 AATCC standard reference detergent. Set the washer for the selected washing cycle and time as per buyer requirement. After washing select the drying procedure.

Machine Cycle

1) Normal / Cotton Sturdy

Washing Temperature

1) $60 \pm 3^\circ\text{C}$

Drying

1) Tumble

After the final washing and drying cycle, condition the Specimen again.

Measurement

After Conditioning, measure and record the distance between each pair of benchmarks to the nearest millimeter.

Calculation

Average % DC = $\frac{A - B}{A} \times 100$

Where,

DC = Average Dimensional Change
A = Average Original Dimension

B = Average Dimension after laundering

Yarn and Chemical quality checking before production

Yarn quality checking before production



At first we are taken 06 cones from each yarn lot which received by store & check all yarn parameter. Such as,

- 1) Count
- 2) CSP
- 3) RKM
- 4) Uster test
- 5) TPI
- 6) Composition
- 7) Specification
- 8) Yarn length

Chemical quality checking before production

a) Check following physical properties from both sample and bulk:

- Chemical Color, Form, Odor.
- Solubility, Grain size (for solid chemicals)

b) Test chemical properties as under:

- pH, Redox, gpl.
- Purity, viscosity, refraction.
- Baume.
- Solid% (for solid chemicals).
- Moisture%
- Yarn wetting & dipping time.
- Dyed lea shade comparison.
- Any other test which might be necessary.



Lab Q.A - (Testing) - Activities system

Major test procedure/section:

- a) Shrinkage Test
- b) Roll to Roll
- c) Online Activities
- d) Internal Test
- e) Chemical Test
- f) Yarn Test

The testing Facilities Available in HDL lab

- Yarn Count
- Lea Strength
- RKM
- Weight Measure
- EPIXPPI
- Dimension Stability
- Stretch Ability
- Growth & Recovery
- Tear Strength
- Tensile Strength
- Seam Slippage
- Seam Strength
- CF to Water
- CF to Saliva
- CF to Perspiration
- CF to HL



- CF to Rubbing
- Skew ness
- Abrasion
- Pilling
- Ph
- Moisture % of chemical Substance
- Purity of chemical Substance

Amazing Washing

The technology which is used to modify the appearance, size, color, outlook, comfort ability, design, fashion etc. of the Amazing garments by which we get our desire garments is known as Amazing washing. Actually, now a days washing is the heart of Amazing because it's the main sector on which the basic 3 requirements of a buyer Shade, Quality & costing is depended fully. So if washing is good & perfect in favor of quality & cost then it will be easier to take an order & convince a buyer.

Process of Amazing Washing

Dry Washing

- Whisker
- Scrapping
- Destroy
- PP spray
- Resin spray
- Tag & Tie
- Bagging
- Grinding
- 3d Whisker
- Crinkle effect



Wet Washing

- De-size
- Enzyme
- Bleaching
- Neutralization
- Tint
- Over dye
- Towel wash
- Acid wash
- Gel Wash.
- Softening

Different Types of Washing Vault

- Shade problem.
- Shrinkage.
- Color fastness.
- Tearing.
- Puckering.
- Marble effect.
- Lycra Missing.
- Spot on garments.
- High or low effect.



CHAPTER-5 MAINTENANCE



Mechanical store:

Maintenance of machinery:

Here mainly one maintenance systems are followed:

Schedule maintenance

In here just following monthly maintenance in every department .

Warping machines maintenance are following

- Motor check
- Monitor check
- Creel check
- Guide bar check
- Stop motion check
- Beam dia check

Dyeing Machines maintenance

Roller granding

Carbon Impression

Bath Cleaning

Bearing Change

Squeeze Pressure check

Dryer temperature check

Sizing maintenance :

Size box Squeeze pressure check

Carbon impression of size box roller

Pre & post dryer temperature check

Reed change

Immersion level check

Monitor settings check



Weaving machine maintenance :

1. Reed check
2. Slay sword check
3. FD check
4. Finger check
5. Wheel check
6. Gripper receiver belt check
7. Monitor check
8. Take up roller check
9. Pressure roller check
10. Batcher roller check
11. Warning lamp check
12. Catch cord bobbin check
13. Yarn guide check
14. Yarn guide roller check
15. Ring frame check
16. Panel board check
17. Heald frame-12 check
18. Overhead cleaner check
19. Pre-winder check
20. Filling cutter check
21. Wastage cutter check
22. Creel stand check
23. Temple check
24. Yarn guide check
25. Contact bar

Finishing maintenance :

1. Loading unit check



UGC & Govt. Approved

Sonargaon University (SU)

সোনারগাঁও ইউনিভার্সিটি (এসইউ)

WE WILL
RISE UP
WE WILL
SHINE

2. Chemical box check
3. Skew device check
4. Dryer unit check
5. Rubber belt pressure check
6. Palmer temperature check
7. Folding check



CHAPTER-6 STORE OR INVENTORY SYSTEM

Inventory:

Inventory is the stock of any item or resources used in an Organization.

Type of Inventory in HDL

- Yarn Store
- Fabric Store
- Chemical Store

Yarn or other Raw Materials and Accessories should be safe from the following:

1. Soiling,
2. Mechanical damage,
3. Environmental damage due to temp. & R.H% which may cause dimensional changes,
4. Fungal Attack,
5. Fading due to light exposure,
6. Damage during Handling

Maintain distance between every single package .



Figure 6.1: Yarn Store

Fabric Store

Safety of fabric store following

Smoke detector

Fire safety

Water line Distance between every fabric stike



Figure 6.2: Fabric Store

Chemical Store

Safety of chemical store following

Fire safety

Distance between every single chemical to others.

Cautions poster of every chemical.



Figure 6.3: Chemical Store



UGC & Govt. Approved

Sonargaon University (SU)

সোনারগাঁও ইউনিভার্সিটি (এসইউ)

WE WILL
RISE UP
WE WILL
SHINE

CHAPTER-7 MARKETING ACTIVITIES

Definition

Textile marketing is the combination of some works like buyer development, work order collection, pricing, sample development approval of sample and fabrics and production follow up, documentation, delivery in time etc.

Flow chart of marketing:

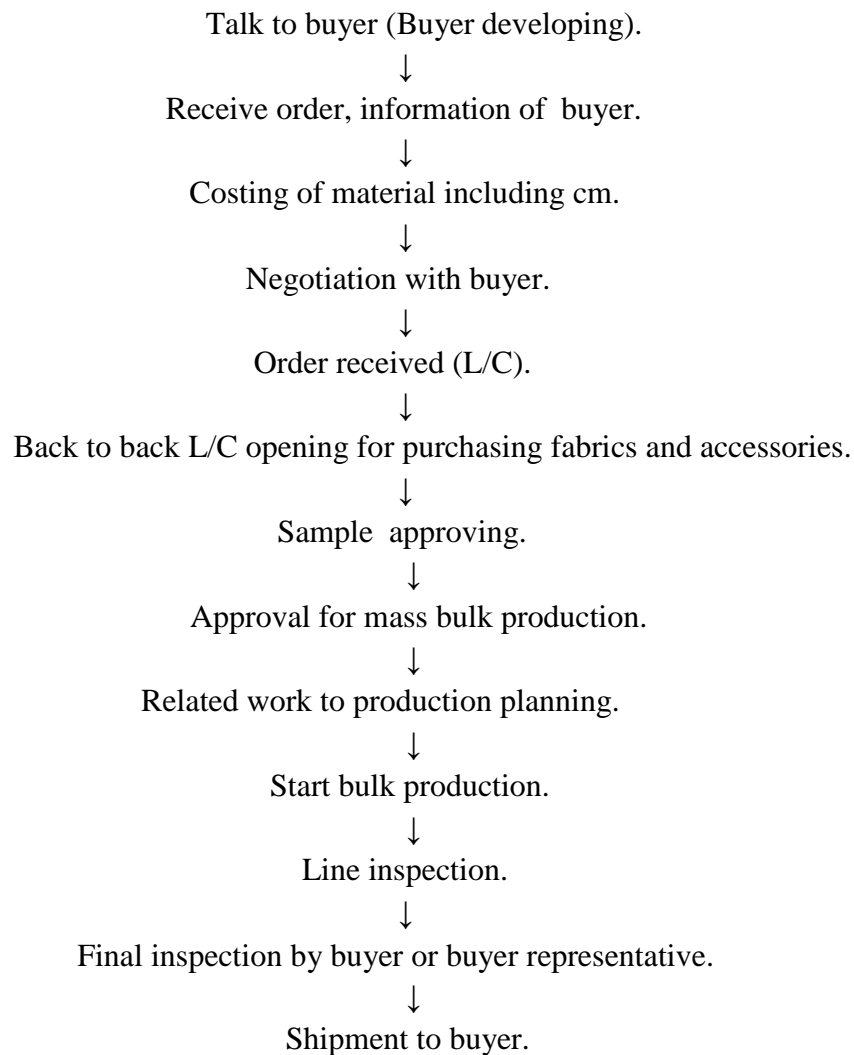

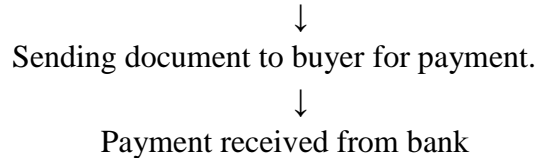

Activities of Marketing:

Activities of Marketing department are as follows:

Communication with Buyers

- Procure Order & Order confirmation
- Costing
- Consumption
- Price Quoting
- Sample Control & Approval
- Potential Sourcing of Materials & Approval Fabric, Trims & Accessories
- Lab dipping & Approval
- Purchasing of Materials
- Testing
- Factory Scheduling / Planning
- Order Follow up: all steps of production & Quality
- Ensure On Time Delivery
- Liaison with the customer during Design, Sourcing, Production & Shipping
- Conduct coordination Meeting with other departments / Pre production meeting
- Attend Buyer's meeting
- Ensure Customer Satisfaction
- Product Development etc.

Duties and Responsibilities:

- Develops and maintains a clearly defined strategy in support of company's mission, vision and objectives.
- Works closely with key individuals and teams to integrate strategic opportunities into the prioritized workflow. Ensure cross-organizational support and extraordinary results for customers and partners.

- Responsible for day-to-day operations including managing employees, vendors, communications, stylistic direction and associated budgets. This position will also provide support to customer service, Sunrise marketing, and product development.
- Carries out supervisory responsibilities in accordance with the organization's policies and applicable laws.
- Manages and directs all pre-launch sampling and distribution of samples to sales customers.
- Work with sales teams and design staff to provide cost estimates.
- Coordinates all aspects of tradeshow.
- Develops business internally by participating in Marketing Tea.



CHAPTER-8 UTILITY SERVICE

8.1 Introduction

Utilities (water, electricity and gas) are essential services that play a vital role in economic and social development. Production and growth of any factory largely depends on regular and uninterrupted service of utilities. In following services fall under utility department-

Gas

Electricity

Water

Compressed air

Steam

Sources of Utility of Integra Apparels (Bangladesh) Ltd:

Gas: Titas T&D company ltd.

Electricity: Generator (Gas & Diesel)

Water: Underground water & Water reservoir

Compressed air: Air compressor

Steam: Boiler

Generator :

Brand- CAT

Origin- U.S.A.

8 MW- 5 units



Figure 8.1: Generator

Boiler:

It is an exhaust gas boiler. It produces steam by using the sensible heat of the exhaust gases of diesel generators, thus saving thermal energy that otherwise would get lost. Then, the steam goes to chiller for cooling purpose.

Brand name : COCHRAN

Origin : Scotland

Serial no: 35/6599

Design Std : BSEN129553

Engine : 2 engine



Figure 8.2: Boiler

Water:

Water comes mainly from underground with the help of centrifugal pumps.

There is a pond in Integra Apparels (Bangladesh) Ltd, which is also used as secondary water source.

A huge underground water reservoir is also present in order to meet the demand in case of fire and any kind of emergency.



UGC & Govt. Approved

Sonargaon University (SU)

সোনারগাঁও ইউনিভার্সিটি (এসইউ)

WE WILL
RISE UP
WE WILL
SHINE

CHAPTER-9

INDUSTRIAL ENGINEERING AND PLANNING

Introduction

R&D (Research and Development) section plays a vital role to the overall production and quality of a fabric. The task of R & D section starts from fabrication and ends at final inspection of finished fabric. That is they used to follow up all the section like fabric planning, knitting, dyeing, printing, finishing, lab, quality control and assurance etc. till the final finished fabric comes out.



Figure 9.1 : R&D Section Textile Industry



Work Flow Chart of R & D Section

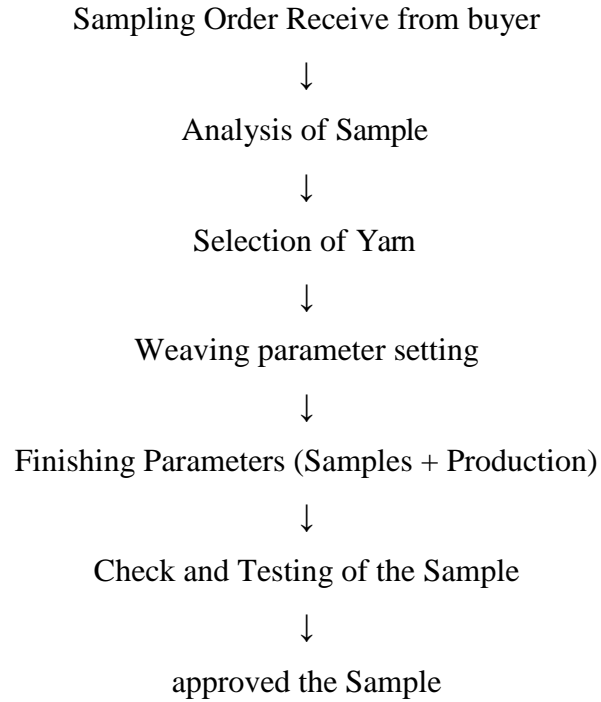



Conclusion

In conclusion we can say that this internship report is really essential for every student. To get idea about Textile industry. By completing this report, we have got overall idea of Amazing fabric manufacturing sector and these may be helpful to know about the technical and management knowledge of Textile industry also these sector related organizations. This is a huge sector and yet to discover the whole.

We want to thank my department Head for giving me great opportunity of learning. This Internship program will help us in the further challenges of life. We try our best to make this project enriched with lots of Amazing fabric related documents. Amazing Fashions Ltd. is really a good experience for me because every person of there so much helpful and give me the proper methods of practical learning. So, at last, there is a hope of eradicating all the obstacles and become the leader of Fabric industries in near future.