

EEE-160009

SONARGOAN UNIVERSITY



POWER GENERATOR & DISTRIBUTION SYSTEM

Submitted by

ID

Mohammad Ullah PK

EEE1501004003

Anamul Haque

EEE1403003156

DEPARTMENT OF ELECTRICAL & ELECTRONICS

SONARGOAN UNIVERSITY

Date of Submission: 5 February, 2016

SONARGOAN UNIVERSITY



Certificate

This is to certify that the internship entitled “Power Generator and Distribution System of Square Textile Ltd” by Mohammad Ullah PK (Id # 1501004003) and Anamul Haque (Id # 1403003156), have been carried out under my supervision.

Supervisor

A handwritten signature in black ink, appearing to read 'Md. Imran Hossain', with the date '16.02.16' written to the right of the signature.

Md. Imran Hossain

Lecturer

Department of Electrical and Electronics Engineering

Sonargoan University

SONARGOAN UNIVERSITY

71, Kawran Bazar, Tejgaon, Dhaka-1215

Phone: (8802) 9123564

Submitted By

<u>Name</u>	<u>Id</u>
Mohammad Ullah PK	EEE1501004003
Anamul Haque	EEE1403003156

Supervisor



19.02.16

Md. Imran Hossain

Lecturer

Department of Electrical and Electronics Engineering

Sonargoan University

Sonargoan University

Candidate's Declaration

It is declared hereby this thesis or any part of it has not been submitted to anywhere else for the award of any degree.

Mohammed ullah PK

.....
Mohammad Ullah PK

Anamul Haque

.....
Anamul Haque

ACKNOWLEDGEMENT

At first we would like to express our heart-felt thanks to almighty ALLAH for his kind blessing for complete of this thesis successfully. We would like to thank to our honorable course teacher & supervisor, Md. Imran Hossain, Lecturer, Department of Electrical and Electronics Engineering. For this guidance, help and encouragement throughout the progress of the thesis. We are very gratefully for his kind advice and instructions.

We would like to thank Idris Ali, General Manager, Square Textile Ltd, Kashimpur, Sardaganj, Gazipur and the Staffs who motivate us thoroughly and the other people, who have made a significant contribution to make this thesis successful. Their guide lines, suggestions and inspiration helped us a lot.

Name	Id
Mohammad Ullah	EEE1501004003
Anamul Haque	EEE1403003156

Chapter 1

Basic Theories

- 1.1 Introduction 01-17
- 1.2 Basic Function of Electric Power Generation
- 1.3 Generator
 - 1.3.1 Type of Generator
 - 1.3.2 Working Principle of AC Generator
- 1.4 Gas Generator
- 1.5 Diesel Generator
- 1.6 Main Components Of A Generator
- 1.7 Description of Main Components of a Generator
- 1.8 Three Phases AC Generator
 - 1.8.1 Advantage of Three Phases AC Generator
- 1.9 Generator Efficiency
- 1.10 Synchronization of Generator
 - 1.10.1 Synchronization Process
- 1.11 Basic Function of Electric Power Distribution 17-34
 - 1.11.1 Electrical Power Distribution
 - 1.11.2 BBT
 - 1.11.2 .1 Bus Bar Trunking System:
 - 1.11.3 Raceways
 - 1.11.4 Feeder Lines and Branch Circuits
 - 1.11.5 Inside Distribution System:
 - 1.12 Switching Equipment
 - 1.13 Distribution Panel Boards

1.14 Low-Voltage Switchgear

1.11.4 Feeder Lines and Branch Circuits

1.11.5 Inside Distribution System:

1.12 Switching Equipment

1.13 Distribution Panel Boards

1.14 Low-Voltage Switchgear

1.15 The Electrical Service Entrance

1.16 Power Distribution System Components

1.17 Single-Phase and Three-Phase Distribution Systems

1.25 Grounding of Distribution Systems

1.29 Cables of Interior Electrical Wiring Systems

1.30 Nonmetallic-Sheathed Cable (NMC)

1.32 Power Factor

Chapter 2

Power generation of Square Textile ltd.

2.1 Introduction

35-53

2.2 Power Source of Square Textile Ltd

2.3 Power Generation System Of Square Textile Ltd

2.3.1 Power House – 1

2.3.1. (A) Gas Generator of Power House -1

2.3.1.(D) Electricity Production

2.3.1(E) Power House -1. Generator Power Grid

2.3.1.(F) Total Power Of Power House -1

2.3.1.(G) Control Panel Of Power House -1

2.3.1.(H) Bus Coupler

2.3.1.(I) BBT

2.3.2 Power House – 2

2.3.2. (A) Gas Generator

2.3.3.(C) Features & Benefits

2.3.3.(D) Total Power Of Power House -3

2.3.4 Power House – 4 (SYL)

2.3.4. (A) Gas Generator Of Power House – SYL

2.4 HFO (Heavy Fuel Oil) Power Plant Specifications

2.5. Cost Calculations

2.6 Synchronization of Generator

Chapter 3

Power Distribution System of Square Textile Ltd.

3.1 Introduction

54-65

3.2 Power Distribution of Square Textile Ltd.

3.3 Distribution Diagram

3.4 Generator Bus Bar

3.4.1 Specification Of Bus Bar:

3.5 UPGD Bus Bar

3.5.1 Specification Of UPGD Bus Bar:

3.6 Distribution Board

- 3.6.1 Small Bus Bar
- 3.6.2 Some Circuit Breakers
- 3.6.3 Current Transformer
- 3.6.4 Grounding System
- 3.6.5 Neutral System
- 3.6.6 Monitor
- 3.7 Change Over
- 3.8. Magnetic Contactor
- 3.9 Plc (Programmable Logic Controller):
- 3.10 Machine Wise Load Distribution Specifications

Chapter 4

Findings, Summary & Recommendations

- 4.1 Findings 66-67
- 4.2 Conclusion
- 4.3 Recommendation

Chapter 5

Supplementary Part

- 5.1 Bibliography 68-71
- 5.2 Appendix
- 5.2.1 Glossary
- 5.2.2 Abbreviation

Chapter 1

Basic Theories

1.1 Introduction:

As our country cannot yield efficient amount of electric energy, our private companies begin to generate electricity with the help of their own generators. Like other companies, Square Textile Ltd also produces sufficient amount of electricity for their factories.

This chapter is basic discussion of total power generation of Square Textile ltd and the process of generation.

1.2 Basic Function of Electric Power Generation:

There are seven fundamental methods of directly transforming other forms of energy into electrical energy:

- Electro-magnetic induction system where a generator dynamo or alternator transforms kinetic energy (energy of motion) into electricity. This is the most used form for generating electricity and is based on Faraday's law. It can be experimented by simply rotating a magnet within closed loops of a conducting material (e.g. copper wire)
- Electrochemistry, the direct transformation of chemical energy into electricity, as in a battery, fuel cell or nerve impulse
- Photovoltaic effect, the transformation of light into electrical energy, as in solar cells

Almost all commercial electrical generation is done using electromagnetic induction, in which mechanical energy forces an electrical generator to rotate. There are many different methods of developing the mechanical energy, including heat engines, hydro, wind and tidal power.

The direct conversion of nuclear potential energy to electricity by beta decay is used only on a small scale. In a full-size nuclear power plant, the heat of a nuclear reaction is used to run a heat engine.

This drives a generator, which converts mechanical energy into electricity by magnetic induction. Most electric generation is driven by heat engines. The combustion of fossil fuels supplies most of the heat to these engines, with a significant fraction from nuclear fission and some from renewable sources.

Now a day's gas generator and diesel generator are used to produce small amount of electric power to run small type of industry.

1.3 Generator

Generator means a machine which converts mechanical source of fuel in electricity. It produces electricity by using different kinds of fuel. It makes mechanical power by using raw materials. Then, It converts it into electricity.

Generator has two basic parts: one is used for getting motion energy and another one is used for producing electricity. To produce electricity we need coiled armature and winding.

Generators are sometimes self-excited, which means the field coils are powered by the current produced by the generator itself. The field coils are connected in series or parallel with the armature winding. When the generator first starts to turn, the small amount of magnetism present in the iron core provides a magnetic field to get it started, generating a small current in the armature. This flows through the field coils, creating a larger magnetic field which generates a larger armature current. This "bootstrap" process continues until the magnetic field in the core levels off due to saturation and the generator reaches a steady state power output.

1.3.1 Type of Generator

According to type of current supply, there is Two Type of Generator

- (i) AC Generator (Alternator)
- (ii) DC Generator (Dynamo)

1.3.2 Working Principle of AC Generator

In case of AC generator, armature is stationary and the field is rotating. When DC voltage is applied to the field then a constant magnetic flux is produced. At the presence of this constant magnetic flux, rotor is rotated through the prime mover. When field (rotor) rotates, armature conductors are cut by the magnetic flux and hence an e.m.f. is induced in it. Since, the magnetic poles are alternately N & S, therefore an alternating e.m.f. is produced in the stator conductor.

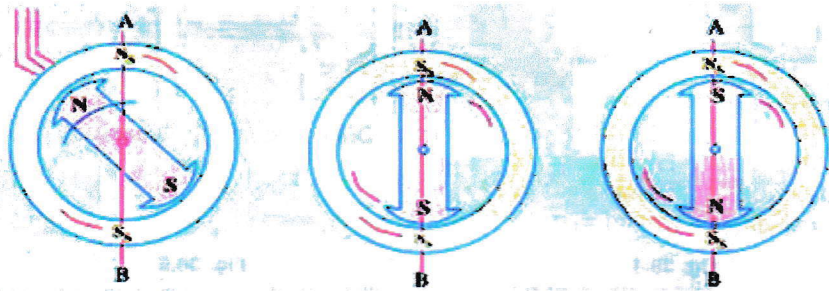

Fig1: Working Principal of AC Generator

A.C Generator works on the principle of electromagnetic induction (motional emf). In generator an induced emf is produced by rotating a coil in a magnetic field. The flux linking the coil changes continuously hence a continuous fluctuating emf is obtained. In order to determine the magnitude and direction of induced e.m.f, let us consider the different positions of the coil which has 'N' turns of wire. In one revolution following positions can be considered.

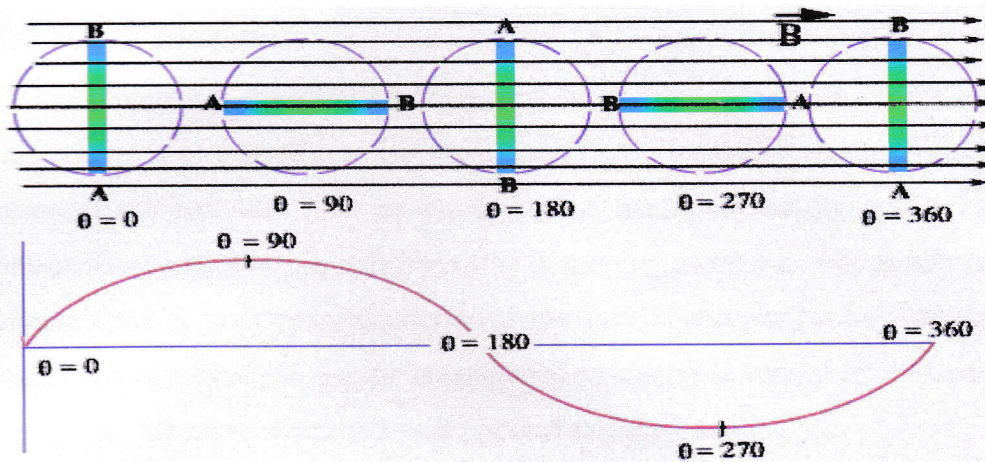

Fig 2: AC generator sine wave

When initially coil is vertical, the length arms AC and BD are moving parallel to the lines of force maximum number of lines link the coil, but rate of change of flux is zero, hence emf is zero.

As the coil moves from this position, sides A.C and BD begin to cut the lines of force and induced emf is setup till it is maximum when the coil is horizontal. It has rotated 90° , 1st quarter is completed.

Further rotation decreases the value of emf, until at the end of 2nd quarter, when coil is vertical, it has rotated 180° , the emf is again zero.

As the coil rotates further from position 3 to position 4, an emf is again induced, but in reverse direction, because A.C and BD are cutting the magnetic lines in opposite direction. The reverse emf reaches to -ve peak value at the end of 3rd quarter. The coil is horizontal and angle of rotation is 270° .

On further rotation, the emf again decreases and becomes zero when the coil returns back to its original position after rotating 360° .

This shows that the coil of generator produces induced emf which reverse its direction $2 \times f$ times in one cycle. Where f = frequency of rotation of coil.

1.4 Gas Generator

Gas generator is a generator where natural gas is used to produce kinetic energy and this energy is converted into electrical energy. As Bangladesh has a large amount of reserved gas naturally it is preferable to use gas generator for producing electric power. Gas generator has two parts one is gas engine another one is alternator. Gas engine convert the chemical energy of gas into kinetic energy by burning it. The kinetic energy from gas engine is converted to electrical energy by alternator. To do this work with more efficient a well planned system is needed.

1.5 Diesel Generator

A diesel generator is the combination of a diesel engine with an electric generator (often an alternator) to generate electrical energy. This is a specific case of engine-generator. A diesel compression-ignition engine often is designed to run on fuel oil, but some types are adapted for other liquid fuels or natural gas. Diesel generating sets are used in places without connection to a power grid, or as emergency power-supply if the grid fails, as well as for more complex applications such as peak-logging, grid support and export to the power grid.

1.6 Main Components Of AC Generator

The main components of an electric generator can be broadly classified as follows:

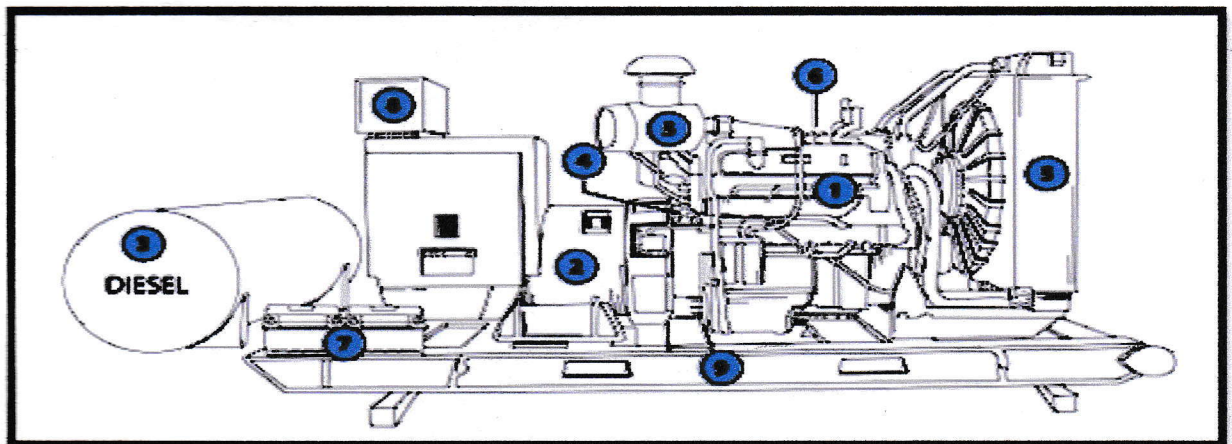

Fig 3 : main components of generator

- | | |
|---------------------------------|---------------------------|
| (1) Engine | (6) Lubrication System |
| (2) Alternator | (7) Battery Charger |
| (3) Fuel System | (8) Control Panel |
| (4) Voltage Regulator | (9) Main Assembly / Frame |
| (5) Cooling and Exhaust Systems | |

1.7 Description of Main Components of a Generator

(1) Engine

The engine is the source of the input mechanical energy to the generator. The size of the engine is directly proportional to the maximum power output the generator can supply. There are several factors that you need to keep in mind while assessing the engine of your generator. The manufacturer of the engine should be consulted to obtain full engine operation specifications and maintenance schedules.

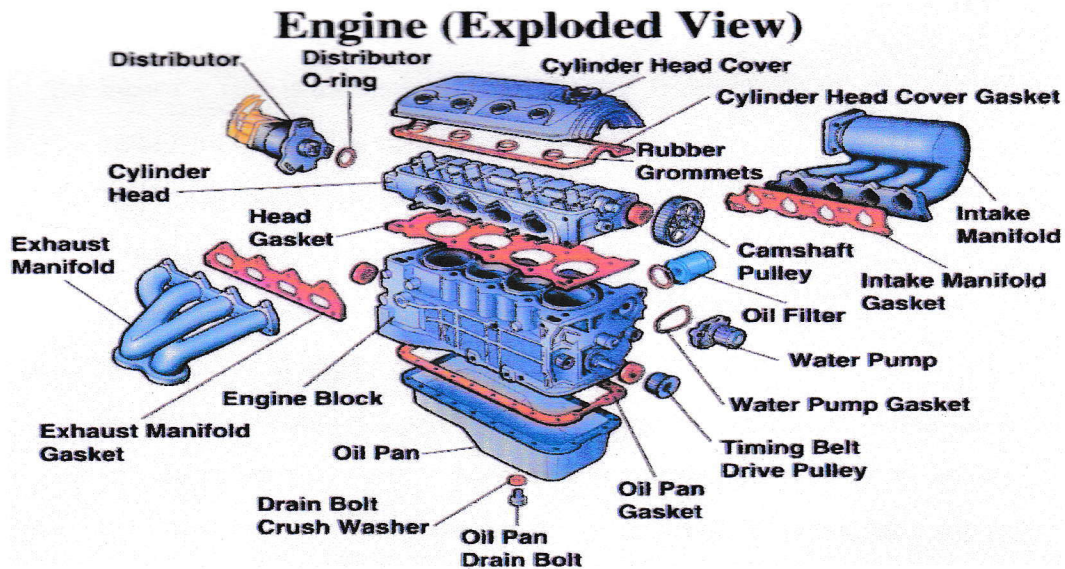

Fig 4 : Engine

2. Alternator

The alternator, also known as the 'genhead', is the part of the generator that produces the electrical output from the mechanical input supplied by the engine.

It contains an assembly of stationary and moving parts encased in housing. The components work together to cause relative movement between the magnetic and electric fields, which in turn generates electricity. Basic parts of alternators are stator and rotor.

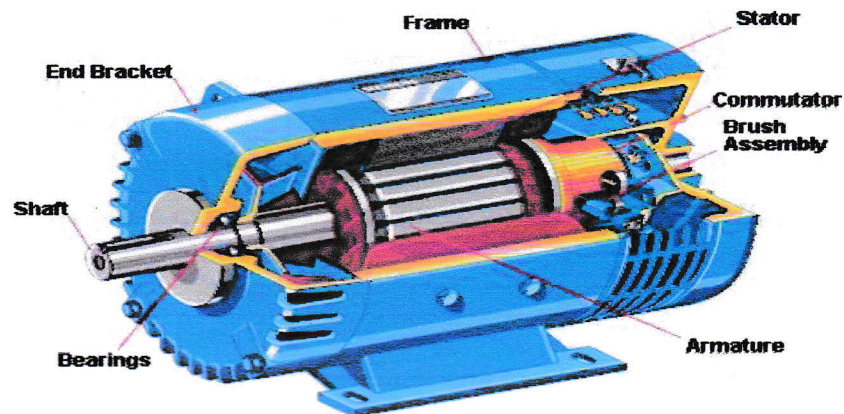

Fig 5: Alternator Components

- (a) **Stator** – This is the stationary component. It contains a set of electrical conductors wound in coils over an iron core.
- (b) **Rotor / Armature** – This is the moving component that produces a rotating magnetic field in any one of the following three ways:
 - (i) **By induction** – These are known as brushless alternators and are usually used in large generators.
 - (ii) **By permanent magnets** – This is common in small alternator units.
 - (iii) **By using an exciter** – An exciter is a small source of direct current (DC) that energizes the rotor through an assembly of conducting slip rings and brushes.

The rotor generates a moving magnetic field around the stator, which induces a voltage difference between the windings of the stator. This produces the alternating current (AC) output of the generator.

It contains an assembly of stationary and moving parts encased in housing. The components work together to cause relative movement between the magnetic and electric fields, which in turn generates electricity. Basic parts of alternators are stator and rotor.

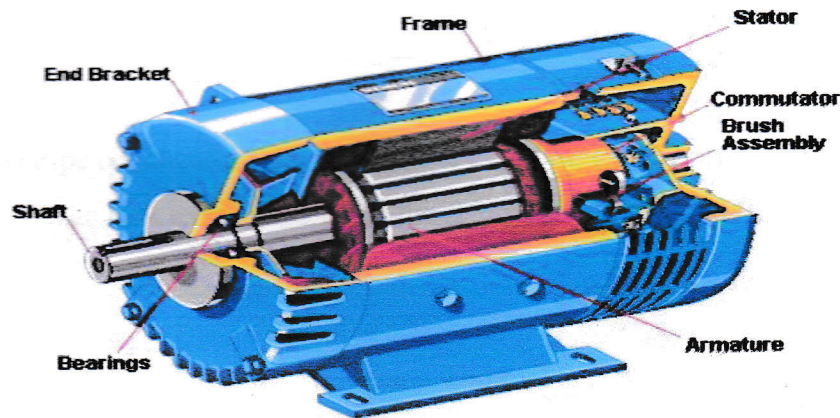

Fig 5: Alternator Components

- (a) **Stator** – This is the stationary component. It contains a set of electrical conductors wound in coils over an iron core.
- (b) **Rotor / Armature** – This is the moving component that produces a rotating magnetic field in any one of the following three ways:
 - (i) **By induction** – These are known as brushless alternators and are usually used in large generators.
 - (ii) **By permanent magnets** – This is common in small alternator units.
 - (iii) **By using an exciter** – An exciter is a small source of direct current (DC) that energizes the rotor through an assembly of conducting slip rings and brushes.

The rotor generates a moving magnetic field around the stator, which induces a voltage difference between the windings of the stator. This produces the alternating current (AC) output of the generator.

(3) Fuel-System

The fuel tank usually has sufficient capacity to keep the generator operational for 6 to 8 hours on an average. In the case of small generator units, the fuel tank is a part of the generator's skid base or is mounted on top of the generator frame. For commercial applications, it may be necessary to erect and install an external fuel tank. All such installations are subject to the approval of the City Planning Division

Common features of the fuel system include the following:

- (a) Pipe connection from fuel tank to engine – The supply line directs fuel from the tank to the engine and the return line directs fuel from the engine to the tank.
- (b) Ventilation pipe for fuel tank – The fuel tank has a ventilation pipe to prevent the build-up of pressure or vacuum during refilling and drainage of the tank. When you refill the fuel tank, ensure metal-to-metal contact between the filler nozzle and the fuel tank to avoid sparks.
- (c) Overflow connection from fuel tank to the drain pipe – This is required so that any overflow during refilling of the tank does not cause spillage of the liquid on the generator set.
- (d) Fuel pump – This transfers fuel from the main storage tank to the day tank. The fuel pump is typically electrically operated.
- (e) Fuel Water Separator / Fuel Filter – This separates water and foreign matter from the liquid fuel to protect other components of the generator from corrosion and contamination.
- (f) Fuel Injector – This atomizes the liquid fuel and sprays the required amount of fuel into the combustion chamber of the engine.

(4) Voltage Regulator

As the name implies, this component regulates the output voltage of the generator. The mechanism is described below against each component that plays a part in the cyclical process of voltage regulation.

- (1) Voltage Regulator: Conversion of AC Voltage to DC Current – The voltage regulator takes up a small portion of the generator's output of AC voltage and converts it into DC current. The voltage regulator then feeds this DC current to a set of secondary windings in the stator, known as exciter windings.
- (2) Exciter Windings: Conversion of DC Current to AC Current – The exciter windings now function similar to the primary stator windings and generate a small AC current. The exciter windings are connected to units known as rotating rectifiers.
- (3) Rotating Rectifiers: Conversion of AC Current to DC Current – These rectify the AC current generated by the exciter windings and convert it to DC current. This DC current is fed to the rotor / armature to create an electromagnetic field in addition to the rotating magnetic field of the rotor / armature.
- (4) Rotor / Armature: Conversion of DC Current to AC Voltage – The rotor / armature now induces a larger AC voltage across the windings of the stator, which the generator now produces as a larger output AC voltage.

This cycle continues till the generator begins to produce output voltage equivalent to its full operating capacity. As the output of the generator increases, the voltage regulator produces less DC current. Once the generator reaches full operating capacity, the voltage regulator attains a state of equilibrium and produces just enough DC current to maintain the generator's output at full operating level.

When you add a load to a generator, its output voltage dips a little. This prompts the voltage regulator into action and the above cycle begins. The cycle continues till the generator output ramps up to its original full operating capacity.

(5)Cooling & Exhaust System

(a) Cooling System

Continuous usage of the generator causes its various components to get heated up. It is essential to have a cooling and ventilation system to withdraw heat produced in the process.

Raw/fresh water is sometimes used as a coolant for generators, but these are mostly limited to specific situations like small generators in city applications or very large units over 2250 kW and above. Hydrogen is sometimes used as a coolant for the stator windings of large generator units since it is more efficient at absorbing heat than other coolants. Hydrogen removes heat from the generator and transfers it through a heat exchanger into a secondary cooling circuit that contains de-mineralized water as a coolant. This is why very large generators and small power plants often have large cooling towers next to them. For all other common applications, both residential and industrial, a standard radiator and fan is mounted on the generator and works as the primary cooling system.

It is essential to check the coolant levels of the generator on a daily basis. The cooling system and raw water pump should be flushed after every 600 hours and the heat exchanger should be cleaned after every 2,400 hours of generator operation. The generator should be placed in an open and ventilated area that has adequate supply of fresh air. The National Electric Code (NEC) mandates that a minimum space of 3 feet should be allowed on all sides of the generator to ensure free flow of cooling air.

1. collant collar
2. Water pump
3. Radiator fan
4. Thermostat
5. Heat Exchanger
6. valve
7. Engine

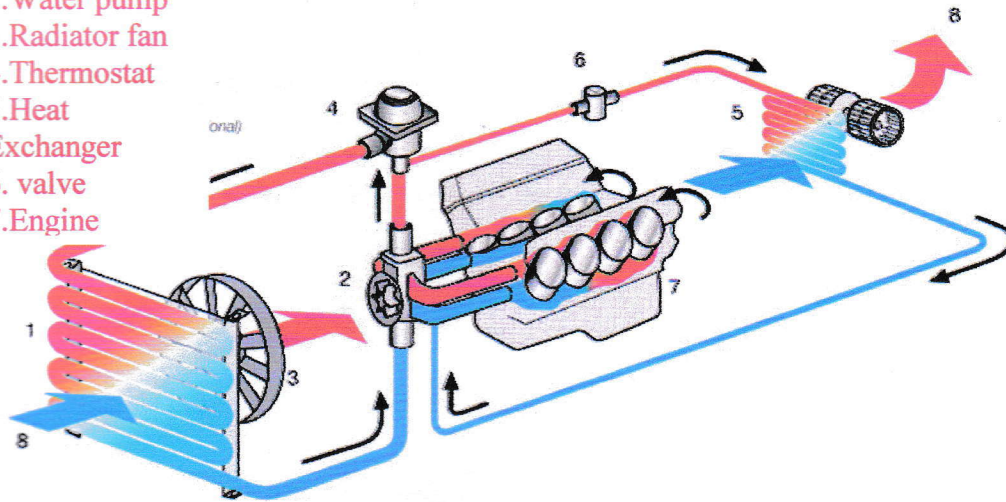

Fig 6: Engine Cooling System

(b) Exhaust System

Exhaust fumes emitted by a generator are just like exhaust from any other diesel or gasoline engine and contain highly toxic chemicals that need to be properly managed. Hence, it is essential to install an adequate exhaust system to dispose of the exhaust gases. This point cannot be emphasized enough as carbon monoxide poisoning remains one of the most common causes for death in post hurricane affected areas because people tend to not even think about it until it's too late.

Exhaust pipes are usually made of cast iron, wrought iron, or steel. These need to be freestanding and should not be supported by the engine of the generator. Exhaust pipes are usually attached to the engine using flexible connectors to minimize vibrations and prevent damage to the generator's exhaust system.

The exhaust pipe terminates outdoors and leads away from doors, windows and other openings to the house or building. You must ensure that the exhaust system of your generator is not connected to that of any other equipment. You should also consult the local city ordinances to determine whether your generator operation will need to obtain an approval from the local authorities to ensure you are conforming to local laws a protect against fines and other penalties.

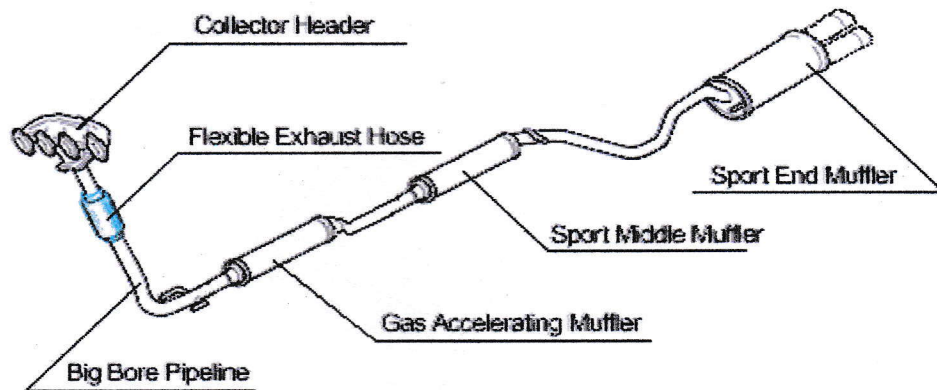

Fig 7: Exhaust System

(6) Lubricating System

Since the generator comprises moving parts in its engine, it requires lubrication to ensure durability and smooth operations for a long period of time. The generator's engine is lubricated by oil stored in a pump. You should check the level of lubricating oil every 8 hours of generator operation. You should also check for any leakages of lubricant and change the lubricating oil every 500 hours of generator operation.

(7) Battery Charger

The start function of a generator is battery-operated. The battery charger keeps the generator battery charged by supplying it with a precise 'float' voltage. If the float voltage is very low, the battery will remain undercharged. If the float voltage is very high, it will shorten the life of the battery. Battery chargers are usually made of stainless steel to prevent corrosion. They are also fully automatic and do not require any adjustments to be made or any settings to be changed.

The DC output voltage of the battery charger is set at 2.33 Volts per cell, which is the precise float voltage for lead acid batteries. The battery charger has an isolated DC voltage output that does not interfere with the normal functioning of the generator.



Fig 8: Battery charger

(8) Control Panel

This is the user interface of the generator and contains provisions for electrical outlets and controls. The following article provides further details regarding the generator control panel. Different manufacturers have varied features to offer in the control panels of their units. Some of these are mentioned below.

- a. Electric start and shut-down – Auto start control panels automatically start your generator during a power outage, monitor the generator while in operation, and automatically shut down the unit when no longer required.
- b. Engine gauges – Different gauges indicate important parameters such as oil pressure, temperature of coolant, battery voltage, engine rotation speed, and duration of operation. Constant measurement and monitoring of these parameters enables built-in shut down of the generator when any of these cross their respective threshold levels.
- c. Generator gauges – The control panel also has meters for the measurement of output current and voltage, and operating frequency.
- d. Other controls – Phase selector switch, frequency switch, and engine control switch (manual mode, auto mode) among others.

(9) Main Assembly / Frame

All generators, portable or stationary, have customized housings that provide a structural base support. The frame also allows for the generated to be earthed for safety.

1.8 Three Phases AC Generator

The three phase AC generator is effectively three single phase AC generators combined into one machine. The poles of the permanent rotating armature magnet swing past each of the non-permanent stator magnets. This induces an oscillating voltage across each of the three coils. Each of the three coils has a pair of lead wires. Three of these leads (one from each coil) join together to form the purple wire that leads to the purple terminal the oscillations of each of these three voltages are out of phase with those of its neighbor by 120 degrees. This is shown in the graph where the voltage across each of the three coils is indicated as a function of time. The horizontal dimension of the graph represents one complete revolution of the rotating armature.

There are two ways of connecting the coils of an AC generator. These two connection types are called star and delta and are shown above. The three phase generator shown in the animation above uses the star connection.

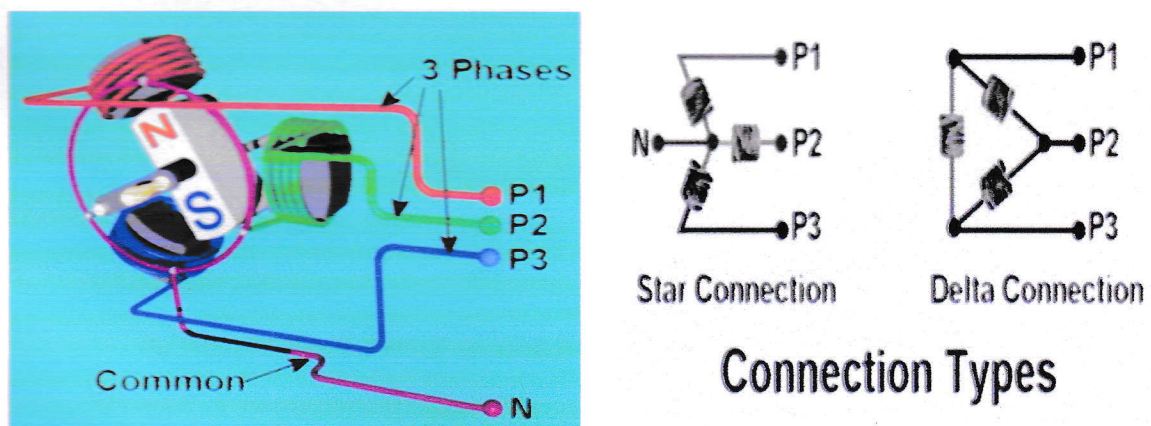

Fig 9: Three Phase AC Generators

1.8.1 Advantage of Three Phases AC Generator

Three phase power is a common form of electrical power and a popular method of electric power transmission. This is due to its inherent benefits for high power transmission and its smooth wave form quality which allow 3 phase electrical equipment to run smoothly and last longer. There are many other benefits to 3 phase power. Three phases has properties that make it very desirable in power distribution. First, all three wires can carry the same current. Secondly, power transfer is constant into a linear and balanced load. Most domestic utility supplied power is single phase only. In most cases three phase power either is not available from a utility company to domestic houses, rural business and farms, at all, or in rare cases where it is, it is split out at the main distribution board. See 3 phase power generating phase converters for solutions to getting 3 phase power where utility companies do not offer it or where it is cost prohibitive. In these situations 1 phase power can be converted to 3 phase power with a phase converter from a company such as ACE Phase Converter or Temuco Phase Converter.

The 3 phase power generated from some of today's high quality Rotary Phase Converters is better balanced with closer voltage tolerances and a smoother wave form than utility supplied power. For this reason the 3 phase power output from these 3 phase generating converters is preferred for sensitive equipment than what is available from utility supplied 3 phase power

1.9 Generator Efficiency

Following are the three generator efficiencies

Mechanical efficiency

$$n_m = B/A = \text{total watts generated in armature} / \text{mechanical power supplied} \\ = E_g I_g / \text{output of driving engine}$$

Electrical efficiency

$$n_e = C/B = \text{watts available in load circuit} / \text{total watts generated} = VI / E_g I_g$$

Overall or commercial efficiency

$$n_c = C/A = \text{watts available in load circuit} / \text{mechanical power supplied}$$

1.10 Synchronization of Generator

In an alternating current electric power system, synchronization is the process of matching the speed and frequency of a generator or other source to a running network. An AC generator cannot deliver power to an electrical grid unless it is running at the same frequency as the network. If two segments of a grid are disconnected, they cannot exchange AC power again until they are brought back into exact synchronization.

There are five conditions that must be met before the synchronization process takes place.

The source (generator or sub-network) must have

- a) Equal line voltage,
- b) Frequency,
- c) Phase sequence,
- d) Phase angle and
- e) Waveform

To that of the system to which it is being synchronized.

1.10.1 Synchronization Process

The sequence of events is similar for manual or automatic synchronization. The generator is brought up to approximate synchronous speed by supplying more energy to its shaft - for example, opening the valves on a steam turbine, opening the gates on a hydraulic turbine, or increasing the fuel rack setting on a diesel engine. The field of the generator is energized and the voltage at the terminals of the generator is observed and compared with the system. The voltage magnitude must be the same as the system voltage.

If one machine is slightly out of phase it will pull into step with the others but, if the phase difference is large, there will be heavy cross-currents which can cause voltage fluctuations and, in extreme cases, damage to the machines.

Synchronizing relays allow unattended synchronization of a machine with a system. Today these are digital microprocessor instruments, but in the past electromechanical relay systems were applied.

A synchronizing relay is useful to remove human reaction time from the process, or when a human is not available such as at a remote controlled generating plant. Synchrosopes or lamps are sometimes installed as a supplement to automatic relays, for possible manual use or for monitoring the generating unit.

Sometimes as a precaution against out-of-step connection of a machine to a system, a "synchro check" relay is installed that prevents closing the generator circuit breaker unless the machine is within a few electrical degrees of being in-phase with the system. Synchro check relays are also applied in places where several sources of supply may be connected and where it is important that out-of-step sources are not accidentally paralleled.

1.11 Basic Function of Electric Power Distribution:

In this part we shall specially know about electrical distribution system inside a building or factory.

1.11.1 Electrical Power Distribution

Electrical power is distributed to the location where it is to be used and then distributed within a building by the power distribution system. Various types of circuit breakers and switchgear are employed for power distribution. Another factor involved in power distribution is the distribution of electrical energy to the many types of loads which are connected to the system. This part of the distribution system is concerned with the conductors, feeder systems, branch circuits, grounding methods and protective and control equipment which is used. The primary emphasis in this chapter will be industrial and commercial power systems.

1.11.2 BBT

BBT or Bus Bar Trunking system is a replacement to traditional cable and panel distribution. MCB, MCCB in BBT is plug in component as bus is extended to consumer area.

Bus bar Trunking System is a not that new technology, in 1930 it was first introduced in USA. Comparing with the conventional wire or cable BBT is far better. In some modern construction, people now prefer BBT other than cable.