



Implementation of Footstep Energy Generation and Monitoring System

Submitted by:

Md. Mahidy Hasan Emon	ID: EEE2202026026
Shohanur Rahaman	ID: EEE2202026038
MD Rownok Shihab	ID: EEE2202026070
Mohammad Ali	ID: EEE2202026085
Arindom Das	ID: EEE2202026040

Supervisor

Md. Ashikur Rahman
Lecturer, Department of EEE
Sonargaon University

Department of Electrical & Electronic Engineering
Sonargaon University (SU)
147/I, Panthapath,
Dhaka-1215,

Date of Submission: January, 2026

DECLARATION

We hereby, declare that the work presented in this project is the outcome of the investigation performed by us under the supervision of Md. Ashikur Rahman, Lecturer of the Electrical & Electronic Engineering Department, Sonargaon University. We also declare that no part of this project report and thereof has been or in being submitted elsewhere for the award of any degree.

We further undertake to identify the university against any loss or damage arising from breach of the forgoing obligation.

Md. Mahidy Hasan Emon
ID: EEE2202026026

Shohanur Rahaman
ID: EEE2202026038

Arindom Das
EEE2202026040

Md. Rownok Shihab
ID: EEE2202026070

Mohammad Ali
ID: EEE2202026085

CERTIFICATEION

This is to certify that the project report “**Implementation of Footstep Energy Generation and Monitoring System**”, is the confide record of the work done by-

for partial fulfillment of the requirement of their degree of B.Sc. in Electrical and Electronic Engineering at Sonargaon University.

The project report has been carried out under my guidance and is a confide record of the successful work. I wish them success in future.

Supervised By

.....
Md. Ashikur Rahman
Lecturer, Department of EEE
Sonargaon University

ACKNOWLEDGEMENT

Firstly, we express our sincere thanks and gratitude to the almighty for his divine blessings which made it possible for us to complete this project successfully.

We are grateful and express our deepest gratitude to Md. Ashikur Rahman, Lecturer, Department of Electrical and Electronic Engineering, Sonargaon University. The deep knowledge and keen interest of our supervisor influenced me to carry out this project. His infinite patience, scholarly guidance, constant encouragement, constant energetic supervision, constructive criticism, valuable suggestions at all levels made this project possible.

The successful completion of this thesis would not have been possible without his constant inspiration and constant guidance. Hence we are extremely pleased to acknowledge our profound gratitude and respect to the maintainer.

We would like to express our gratitude to our Head of Department, as this project was completed under the Head of Department of Electrical and Electronics Engineering, Sonargaon University, Bangladesh.

We would like to thank our entire course mates from Sonargaon University, who participated in this discussion while completing the course work.

The author is grateful to all the respected faculty members of the Department of Electrical and Electronics Engineering for their cooperation and vital assistance in the successful completion of the thesis work.

ABSTRACT

The Implementation of Footstep Energy Generation and Monitoring System is an IoT-based solution designed to harvest and monitor energy generated from human footsteps using piezoelectric sensors. The project aims to demonstrate how everyday movements can be converted into usable electrical energy while providing real-time feedback through an online dashboard. By integrating hardware sensing, power management, and wireless data communication, this system highlights a practical approach to renewable micro-energy generation.

The setup uses six 35 mm piezo sensors connected through a voltage divider and monitored by an ESP32 microcontroller. As footsteps apply pressure on the piezo elements, an AC voltage is produced and measured using a DC voltage sensor. The ESP32 processes the signal, calculates the generated voltage, counts each valid footstep, and displays the information on a 16×2 I2C LCD. A buzzer provides audible feedback for every detected step, enhancing user interaction.

To ensure portability, the system is powered using two 3.7 V batteries configured in a 2S setup and regulated using an MP1584 buck converter. All components are mounted on a durable PVC and acrylic platform for stability. The ESP32 connects to Wi-Fi and publishes live data step count and corresponding voltage to an MQTT broker.

Users can monitor the readings through a custom mobile application built with MQTT. The app displays real-time step count and voltage generation, making the system suitable for educational demonstrations, smart walkways, and renewable-energy awareness initiatives. This project effectively combines energy harvesting, IoT communication, and embedded systems to showcase a functional footstep-powered energy model.

TABLE OF CONTENTS

Table of contents:	Page no:
Name of submitted	i
Declaration	ii
Certificate	iii
Acknowledgement	iv
Abstract	v

INTRODUCTION

CHAPTER-1:

1.1 Introduction	1
1.2 Objectives	1
1.3 Background of the work	2
1.4 Problem statement	3

LITERATURE REVIEW

CHAPTER-2:

2.1 Existing System	4
2.2 Literature Review	5

METHODOLOGY

CHAPTER-3:

3.1 Description of methodology	6
3.2 System Architecture	6
3.3 Requirement analysis	7
3.4 Hardware requirements	8-28
3.5 Software requirements	29-32

DESIGN AND DEVELOPMENT

CHAPTER-4:	Page no:
4.1 System Design & Piezo sensor	33
4.2 Block Diagram	34
4.3 Flow Chart	35
4.4 Circuit Diagram	36
4.5 Working Procedure	36-37

IMPLEMENTATION & TESTING

CHAPTER-5:	
5.1 Implementation of the project	38
5.2 Results	38

CONCLUSION

CHAPTER-6:	
6.1 Conclusion	39
6.2 Future works	40

LIST OF TABLE

TABLE NO:		
Table 3.1	List of the components	7
Table 3.2	Lcd pin out configuration	10

LIST OF FIGURE

FIGURE NO:		Page no:
Figure 3.1	System Architecture	06
Figure 3.2	ESP32 Wi-Fi Modules	08
Figure 3.3	Lcd display	09
Figure 3.4	Inter-Integrated Circuit (I2C)	11
Figure 3.5	35mm piezo sensor	11
Figure 3.6	DC Voltage Sensor	13
Figure 3.7	1K Ω Resistor	14
Figure 3.8	Buzzer	15
Figure 3.9	BC547	16
Figure 3.10	MP1584 Buck Converter	18
Figure 3.11	3.7V Li-ion battery	19
Figure 3.12	2s battery case	21
Figure 3.13	Veroboard	22
Figure 3.14	Male and Female header	23
Figure 3.15	Power Switch	25
Figure 3.16	PVC white board	26
Figure 3.17	Acrylic transparent board	27
Figure 3.18	Arduino Software Code	29
Figure 3.19	Mit app inventor	31
Figure 4.1	Block Diagram	34
Figure 4.2	Flow Chart	35
Figure 4.3	Circuit connection diagram	36
Figure 5.1	Project picture	38
References:		41

CHAPTER 1

INTRODUCTION

1.1 Introduction:

The Implementation of Footstep Energy Generation and Monitoring System is an innovative IoT-based project designed to generate electrical energy from human footsteps using piezoelectric sensors. With the rising global demand for renewable and sustainable energy sources, piezoelectric energy harvesting has gained attention as a practical method for producing small amounts of power from everyday activities [1]. This project focuses on converting mechanical pressure created during walking into electrical energy and monitoring the generated output in real time in this system, multiple piezoelectric sensors are placed beneath a platform to capture the pressure exerted by footsteps. The generated voltage is measured using a DC voltage sensor and processed by an ESP32 microcontroller. The ESP32 counts each step, reads the voltage level, and displays the results on a 16×2 LCD. The system also includes IoT functionality through MQTT, allowing users to view step count and voltage data through a mobile application [2]. The Implementation of a Footstep Energy Generation & Monitoring System demonstrates how human movement can contribute to micro-energy production. This project showcases energy harvesting techniques, embedded system implementation, and wireless data communication, making it suitable for educational demonstrations, smart flooring, and sustainability-focused applications [3].

1.2 Objectives:

The main objective of this project is.

- To design and develop a smart piezoelectric energy harvesting system capable of converting footstep pressure into usable electrical energy by utilizing multiple piezo sensors arranged beneath a stable walking platform. This objective focuses on capturing maximum mechanical stress and transforming it into measurable voltage output for analysis and experimentation.
- To integrate IoT functionality using the MQTT protocol so users can remotely monitor live energy generation data through a mobile application. This supports remote accessibility and modern smart monitoring features.
- To implement an ESP32-based monitoring unit that accurately reads voltage generated from the piezo sensors, counts each valid footstep, and processes data in real time. This

ensures precise detection of user interaction and consistent performance throughout the system's operation.

- To display all generated data, including step count and voltage readings, on a 16×2 LCD, providing instant visual feedback to the user and improving the overall usability of the prototype. The system aims to present information clearly and efficiently.
- To demonstrate a low-cost, portable, and eco-friendly energy harvesting model that promotes awareness about sustainable technologies and highlights practical applications of piezoelectric power in walkways, public spaces, and educational projects.

1.3 Background of the work:

The Implementation of a Footstep Energy Generation & Monitoring system is based on the concept of piezoelectric energy harvesting, a technique where mechanical stress applied to a material generates electrical energy. Piezoelectricity has been widely researched for several decades due to its ability to convert small vibrations, pressure, and movement into usable electrical power. With the increasing global emphasis on renewable energy and sustainable technologies, energy harvesting from human footsteps has become an attractive solution for powering low-energy devices, especially in high-traffic public areas. In many urban locations, thousands of people walk daily in schools, stations, footpaths, markets, and airports, creating an opportunity to capture mechanical energy that is normally wasted. This project aims to explore this potential by integrating multiple piezo sensors beneath a platform, where each footstep produces a small voltage that can be measured, analyzed, and stored. The use of an ESP32 microcontroller enhances the system by providing fast processing, built-in Wi-Fi, and compatibility with IoT applications. Through a DC voltage sensor, the ESP32 reads the output from the piezo elements, calculates step counts, and displays the results on a 16×2 LCD. Additionally, the system connects to an MQTT broker, allowing real-time monitoring through a mobile application, which modernizes the concept by adding remote accessibility. The background of this work also reflects the growing demand for smart systems that combine hardware, software, and IoT to create intelligent monitoring platforms. By studying previous research and existing energy harvesting systems, it becomes clear that piezoelectric technology is a promising method for producing clean micro-energy in an efficient and environmentally friendly manner. This project builds on these foundations to demonstrate a practical prototype that not only generates power but also educates users about renewable energy concepts, sustainability practices, and modern IoT-based energy tracking methods.

1.4 Problem statement:

The increasing global demand for clean and renewable energy has created a need for alternative solutions that can generate power from everyday human activities. However, most existing energy harvesting systems remain expensive, complex, or unsuitable for small-scale applications. In public places such as schools, shopping malls, transportation hubs, and walkways, thousands of footsteps are produced daily, yet this mechanical energy is completely wasted. There is no widely available, low-cost system that can convert footstep pressure into usable electrical energy while also monitoring the generated output in real time. Additionally, traditional renewable sources such as solar or wind power depend heavily on environmental conditions, making them unreliable in certain situations. Another problem is the lack of awareness among students and the general public about how micro-energy harvesting technologies work, and how they can be integrated with IoT for smart monitoring. Many existing prototypes do not provide real-time data visualization, do not count user footsteps accurately, and lack remote monitoring features. Furthermore, most piezoelectric setups generate small voltages that need proper measurement, processing, and display for meaningful evaluation. Therefore, there is a need for a simple, affordable, and IoT-enabled system that can convert footstep force into measurable electrical energy, display the data instantly, and allow remote tracking through a mobile application.

CHAPTER 2

LITERATURE REVIEW

2.1 Existing System Analysis:

Existing systems for energy harvesting from human footsteps have been explored in various research projects and experimental prototypes, but most of them face limitations in terms of efficiency, cost, implementation complexity, and real-time monitoring. Traditional piezoelectric floor tiles used in commercial applications are often expensive due to the use of high-quality piezo materials, advanced load-distribution mechanisms, and durable construction designed for heavy foot traffic. These systems are typically found in airports, shopping centers, or exhibitions, where energy is harvested from large crowds, but they remain inaccessible for small-scale or educational projects. Many early prototypes focused solely on generating electricity using a few piezoelectric discs without incorporating proper voltage measurement or step-count accuracy, resulting in inconsistent performance and unreliable data. Some existing solutions rely on microcontrollers like Arduino Uno, which lack built-in wireless communication, limiting their ability to support IoT-based monitoring. As a result, users cannot view the energy output on mobile devices or track real-time performance remotely. Other systems capture energy but do not include display units such as LCDs, making it difficult to observe voltage changes instantly. Additionally, previously developed models often ignore data storage and publishing features, preventing long-term analysis of energy generation patterns. Many studies mention that piezoelectric sensors produce low voltage outputs and require amplification or regulated measurement circuits, but earlier systems sometimes failed to include proper signal conditioning, leading to inaccurate readings. Some designs were also bulky, lacked portability, and did not integrate modern IoT protocols like MQTT for seamless communication. Due to these limitations, existing systems are not suitable for low-cost implementation in schools, colleges, or small projects. Therefore, despite research progress, there remains a clear need for a compact, affordable, accurate, and IoT-enabled footstep energy harvesting system that not only generates power but also monitors step count, voltage level, and performance in real time, making the concept accessible and practical for wider use.

2.2 Literature Review:

Piezoelectric energy harvesting has been widely discussed in scientific literature as a promising method for generating small amounts of electrical power from mechanical stress and vibration. Early studies such as those by Kymissis et al. (1998) demonstrated how piezoelectric materials could be embedded in shoes to generate energy from walking, proving the feasibility of human-powered micro-generation [1]. Subsequent research expanded this idea to flooring systems, where piezoelectric tiles installed in crowded areas were used to produce electricity capable of powering small LEDs or sensors. Priya and Inman (2009) highlighted the advantages of piezoelectric ceramics, including their high energy density and mechanical durability, making them suitable for continuous footstep pressure applications [2]. Khan, Khattak, and colleagues (2012) further explained that piezoelectric floor systems could be integrated into smart city environments, although cost and complexity were major challenges that prevented widespread deployment [3]. Recent studies have focused on enhancing voltage output, improving system efficiency, and integrating modern microcontrollers for data processing. Research by Dhawan et al. (2016) explored the combination of multiple piezo discs arranged in series and parallel connections to maximize voltage and current generation, showing that proper configuration significantly affects performance [4]. Another study by S. Abdullah and M. Rahman (2018) used microcontrollers to measure voltage, count footsteps, and display results, but their system lacked remote monitoring capabilities, limiting real-time analysis. With the rise of IoT technologies, scholars such as Patel and Sharma (2020) proposed systems that incorporate wireless communication modules, though many relied on older technologies such as Bluetooth, which restricts data range and flexibility [5]. Recent advancements suggest integrating Wi-Fi-enabled microcontrollers like the ESP32 with cloud-based MQTT protocols to improve remote energy monitoring. Studies by J. Fernandes (2021) and A. Noor (2022) emphasized that IoT-based monitoring systems significantly improve accessibility and data visualization, enabling users to observe voltage generation, usage patterns, and system performance in real time. However, most existing prototypes remain either too expensive, lack user-friendly interfaces, or fail to combine both energy harvesting and live data transmission into a compact and affordable system. This gap in current literature highlights the need for a low-cost, efficient, and IoT-enabled piezoelectric footstep energy system that supports real-time step counting, voltage monitoring, and mobile data accessibility for educational and practical applications.

CHAPTER 3

METHODOLOGY

3.1 Description of Methodology:

The methodology begins by installing multiple piezoelectric sensors beneath a platform to capture mechanical pressure from footsteps. The generated voltage is measured using a DC voltage sensor and read by the ESP32 microcontroller. The system processes step count and voltage data and displays the results on a 16×2 LCD.

The ESP32 sends the collected data to an MQTT broker using Wi-Fi for real-time monitoring. A mobile application receives the step count and voltage values, allowing users to observe system performance remotely.

3.2: System Architecture:

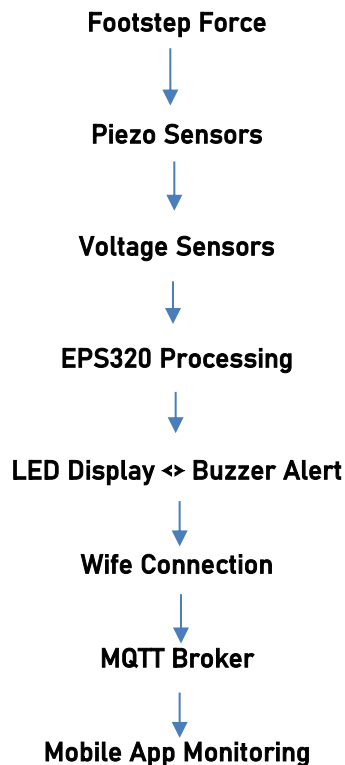

Figure 3.1: System Architecture

3.3 Requirement Analysis:

Table 3.1 List of the Components

SL NO:	Particulars	Qty.	Unit
1	ESP32 Micro-controller	1	Nos
2	35mm piezo sensors	6	Nos
3	DC voltage sensor	1	Nos
4	16x2 LCD display	1	Nos
5	i2c Driver	1	Nos
6	Buzzer	1	Nos
7	1k resistor	1	Nos
8	3.7V battery	2	Nos
9	2s battery case	1	Nos
10	MP1584	1	Nos
11	Veroboard	1	Lot
12	Male Female header	2	Nos
13	Power Switch	1	Nos
14	Jumper wire	-	Lot
15	PVC white borad	-	Lot
16	Acrylic transparent board	-	Lot

3.4 Hardware Requirements:

The Implementation of a Footstep Energy Generation & Monitoring system requires several hardware components to ensure accurate energy harvesting, data processing, display, and IoT communication.

1. ESP32
2. 6x 35mm piezo sensors
3. DC voltage sensor
4. 16x2 LCD display with i2c Driver
5. Buzzer
6. BC547
7. 1k resistor
8. 2x 3.7V battery
9. 2s battery case
10. MP1584
11. Veroboard
12. Male Female header
13. Power Switch
14. Jumper wire
15. PVC white board
16. Acrylic transparent board

1. ESP32 Module:

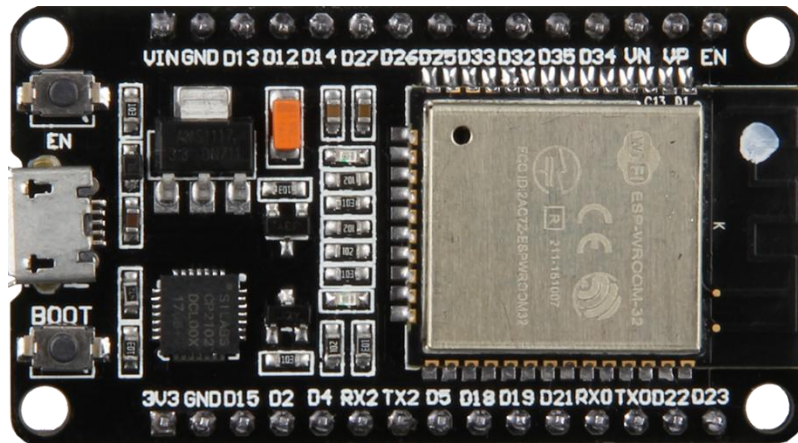

Figure 3.2 ESP32 Wi-Fi Modules

Specifications:

- Dual-core Xtensa LX6 32-bit processor (up to 240 MHz)
- Built-in Wi-Fi (802.11 b/g/n) and Bluetooth (Classic + BLE)
- 520 KB SRAM and external flash support
- 12-bit ADC, 2× DAC, capacitive touch inputs

- Multiple communication interfaces: UART, I2C, SPI, PWM, I2S
- Operating voltage: 3.0V–3.6V
- Low-power modes: Light Sleep, Deep Sleep

The ESP32 is a powerful and versatile microcontroller widely used in embedded systems, IoT applications, smart devices, and energy monitoring projects. Developed by Espressif Systems, it is known for its high processing capability, integrated wireless communication features, and low-power performance. The ESP32 contains a dual-core Xtensa 32-bit LX6 processor that can run at speeds up to 240 MHz, allowing it to handle multiple tasks simultaneously with efficiency and stability. Its architecture supports both single-core and dual-core operation, making it suitable for complex real-time applications that require multitasking, such as sensor data processing, wireless transmission, and display control.

A major advantage of the ESP32 is its built-in Wi-Fi (802.11 b/g/n) and Bluetooth (Classic and BLE), which enables seamless connectivity with mobile devices, cloud servers, and IoT platforms without the need for external modules. This makes the ESP32 an ideal choice for smart monitoring systems, home automation, energy tracking, and wireless sensor networks. The microcontroller also includes multiple GPIO pins, analog-to-digital converters, digital-to-analog converters, touch sensors, UART, I2C, SPI, PWM, and timer peripherals, allowing it to interface with a wide range of sensors and actuators.

In addition to its functional features, the ESP32 is designed with energy efficiency in mind. It supports several power-saving modes, including light sleep and deep sleep, making it suitable for battery-powered devices. Its ADC capabilities allow it to measure sensor outputs, such as voltage from piezoelectric elements, with good accuracy. The ESP32 is programmed using the Arduino IDE, Platform IoT, or the ESP-IDF framework, providing flexibility for both beginners and professional developers.

The combination of processing power, integrated communication, and low cost has made the ESP32 a popular microcontroller for innovative projects. In systems like the Implementation of Footstep Energy Generation and Monitoring System device, the ESP32 plays a central role by reading sensor data, calculating step counts, displaying results, and publishing information through MQTT for real-time monitoring. Its reliable performance and wide compatibility make it one of the most effective microcontrollers for modern IoT-based applications.

LCD

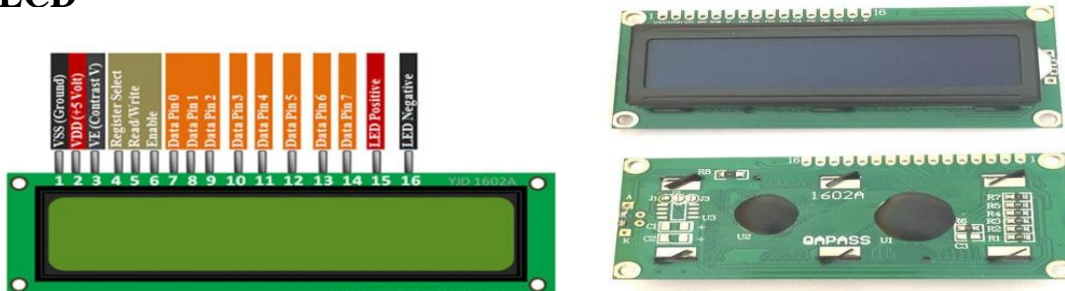

Figure 3.3 LCD Display

LCD Pinout Configuration

Table 3.2 LCD Pin Out Configuration

Pin No:	Pin Name:	Description
1	Vss (Ground)	Ground pin connected to system ground
2	Vdd (+5 Volt)	Powers the LCD with +5V (4.7V – 5.3V)
3	VE (Contrast V)	Decides the contrast level of display. Grounded to get maximum contrast.
4	Register Select	Connected to Microcontroller to shift between command/data register
5	Read/Write	Used to read or write data. Normally grounded to write data to LCD
6	Enable	Connected to Microcontroller Pin and toggled between 1 and 0 for data acknowledgement
7	Data Pin 0	Data pins 0 to 7 forms a 8-bit data line. They can be connected to Microcontroller to send 8-bit data. These LCD's can also operate on 4-bit mode in such case Data pin 4,5,6 and 7 will be left free.
8	Data Pin 1	It can be connected to microcontroller to send 8-bit data.
9	Data Pin 2	It can be connected to microcontroller to send 8-bit data.
10	Data Pin 3	It can be connected to microcontroller to send 8-bit data.
11	Data Pin 4	It can be connected to microcontroller to send 8-bit data. This leaves the point free when LCDs also operate in 4-bit mode.
12	Data Pin 5	It can be connected to microcontroller to send 8-bit data. This leaves the point free when LCDs also operate in 4-bit mode.
13	Data Pin 6	It can be connected to microcontroller to send 8-bit data. This leaves the point free when LCDs also operate in 4-bit mode.
14	Data Pin 7	It can be connected to microcontroller to send 8-bit data. This leaves the point free when LCDs also operate in 4-bit mode.
15	LED Positive	Backlight LED pin positive terminal
16	LED Negative	Backlight LED pin negative terminal

I2C:



Figure 3.4 Inter-Integrated Circuit (I2C)

I2C (Inter-Integrated Circuit) is a serial communication protocol used to connect microcontrollers and other devices to communicate with each other. When you're dealing with an LCD display using I2C, it typically involves an LCD screen with an I2C interface (usually an I2C backpack or an I2C-enabled LCD module) to reduce the number of pins required to connect it to a microcontroller.

35mm piezo sensor:

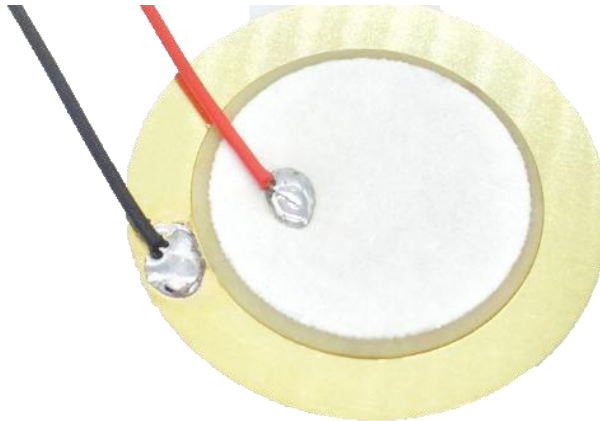

Figure 3.5 35mm piezo sensor

Specifications of 35mm Piezo Sensor

- Diameter: 35 mm
- Material: Brass disc with piezoelectric ceramic layer
- Output type: AC voltage
- Voltage generation range: few millivolts to several volts (depends on force)
- Thickness: 0.3–0.5 mm (approx.)
- Operating temperature: -20°C to $+70^{\circ}\text{C}$
- Sensitivity: High (suitable for vibration, impact, and pressure detection)
- Power requirement: No external power needed

Working Principle

The 35mm piezo sensor works based on the piezoelectric effect, which states that certain materials generate electrical charge when mechanical stress is applied. When force, pressure, vibration, or impact bends the brass–ceramic disc, the crystal structure inside the ceramic layer becomes polarized. This polarization produces an electrical voltage across the sensor’s terminals. The magnitude of the voltage depends on the strength, speed, and angle of the applied force. Because the output is AC, it may require rectification, filtering, or voltage division when interfacing with microcontrollers like the ESP32.

Description (Updated, ~350 words)

The 35mm piezoelectric sensor is a versatile and highly responsive transducer widely used in vibration detection, impact sensing, pressure measurement, and small-scale energy-harvesting systems. It consists of a thin circular brass plate with a bonded piezoelectric ceramic layer that deforms when subjected to physical force. This simple yet powerful structure allows the sensor to convert mechanical energy into electrical energy, making it an essential component in systems like Implementation of a Footstep Energy Generation & Monitoring system platforms.

One of the main advantages of the 35mm piezo sensor is its excellent sensitivity. Even small vibrations or light taps generate measurable voltage outputs, while stronger impacts, such as human footsteps, can produce several volts. This makes the sensor ideal for energy-capturing applications where human motion is converted into electrical signals. Its thin and lightweight design allows easy installation under floors, mats, acrylic sheets, PVC boards, or any surface where pressure is applied.

The 35mm piezo sensor does not require any external power for operation, making it a cost-effective and energy-efficient choice for embedded systems. However, because the voltage produced can sometimes be unstable or high, supporting circuits like resistors, capacitors, voltage dividers, and rectifiers are commonly used to protect microcontroller inputs and stabilize measurements.

In footstep energy systems, multiple piezo sensors are often connected in parallel to increase current capability or in series to increase voltage output. When mounted properly, the sensors can withstand repeated mechanical stress, offering reliability for long-term use.

Overall, the 35mm piezo sensor is a critical component for innovative projects that require motion detection, impact sensing, or small-scale energy generation. Its high sensitivity, low cost, durability, and ease of integration make it an excellent choice for modern IoT and smart energy applications.

DC voltage sensor:



Figure 3.6: DC Voltage Sensor

Specifications of 35mm Piezo Sensor

- Diameter: 35 mm
- Material: Brass disc with piezoelectric ceramic layer
- Output type: AC voltage
- Voltage generation range: few millivolts to several volts (depends on force)
- Thickness: 0.3–0.5 mm (approx.)
- Operating temperature: -20°C to $+70^{\circ}\text{C}$
- Sensitivity: High (suitable for vibration, impact, and pressure detection)
- Power requirement: No external power needed

Working Principle

The 35mm piezo sensor works based on the **piezoelectric effect**, which states that certain materials generate electrical charge when mechanical stress is applied. When force, pressure, vibration, or impact bends the brass–ceramic disc, the crystal structure inside the ceramic layer becomes polarized. This polarization produces an electrical voltage across the sensor’s terminals. The magnitude of the voltage depends on the strength, speed, and angle of the applied force. Because the output is AC, it may require rectification, filtering, or voltage division when interfacing with microcontrollers like the ESP32.

Description

The 35mm piezoelectric sensor is a versatile and highly responsive transducer widely used in vibration detection, impact sensing, pressure measurement, and small-scale energy-harvesting systems. It consists of a thin circular brass plate with a bonded piezoelectric ceramic layer that deforms when subjected to physical force. This simple yet powerful structure allows the sensor to convert mechanical energy into electrical energy, making it an essential component in systems like Implementation of a Footstep Energy Generation & Monitoring system platforms.

One of the main advantages of the 35mm piezo sensor is its excellent sensitivity. Even small vibrations or light taps generate measurable voltage outputs, while stronger impacts, such as human footsteps, can produce several volts. This makes the sensor ideal for energy-capturing

applications where human motion is converted into electrical signals. Its thin and lightweight design allows easy installation under floors, mats, acrylic sheets, PVC boards, or any surface where pressure is applied.

The 35mm piezo sensor does not require any external power for operation, making it a cost-effective and energy-efficient choice for embedded systems. However, because the voltage produced can sometimes be unstable or high, supporting circuits like resistors, capacitors, voltage dividers, and rectifiers are commonly used to protect microcontroller inputs and stabilize measurements.

In footstep energy systems, multiple piezo sensors are often connected in parallel to increase current capability or in series to increase voltage output. When mounted properly, the sensors can withstand repeated mechanical stress, offering reliability for long-term use.

Overall, the 35mm piezo sensor is a critical component for innovative projects that require motion detection, impact sensing, or small-scale energy generation. Its high sensitivity, low cost, durability, and ease of integration make it an excellent choice for modern IoT and smart energy applications.

Resistor :

A resistor is a passive two-terminal electrical component that implements electrical resistance as a circuit element. Resistors act to reduce current flow, and, at the sometime, act to lower voltage levels within circuits. Resistors may have fixed resistances or variable resistances, such as those founding thermostats, visitors, trimmers, photo resistors, hamsters and potentiometers. The current through a resistor is in direct proportion to the voltage across the resistor's terminals. This relationship is represented by Ohm's law



Figure 3.7: 1KΩ Resistor

Theory of operation

The behavior of an ideal resistor is dictated by the relationship specified by Ohm 'slaw:

$$V = I.R$$

Ohm's law states that the voltage (V) across a resistor is proportional to the current(I), where the constant of proportionality is the resistance (R).

Equivalently, Ohm's law can be stated:

$$I = V/R$$

This formulation states that the current (I) is proportional to the voltage (V) and inversely proportional to the resistance (R). This is directly used in practical computations. For example, if a 300-ohm resistor is attached across the terminals of a 12 volt battery, then a current of $12 / 300 = 0.04$ amperes flows through that resistor.

Buzzer :



Figure 3.8: Buzzer

Specifications of Buzzer

- Type: Active/Passive buzzer (project usually uses small 5V active buzzer)
- Operating voltage: 3.3V–5V
- Sound output: 75–95 dB (depending on model)
- Frequency: Fixed (active) or variable (passive)
- Current consumption: 10–30 mA
- Interface: Two-pin or three-pin module
- Compatible with: ESP32, Arduino, Raspberry Pi
- Lifetime: More than 10,000 sound cycles

Working Principle

A buzzer works on the principle of electromechanical or piezoelectric vibration. In most electronic projects, a piezoelectric buzzer is used, which creates sound when an electrical signal causes the piezoelectric material inside to vibrate rapidly. These vibrations generate pressure waves in the air, producing audible sound. Active buzzers contain a built-in oscillator, so they produce sound automatically when powered. Passive buzzers require an external frequency signal from the microcontroller to create sound.

Description

A buzzer is a simple audio signaling device widely used in electronic systems to provide alerts, notifications, and feedback to users. In smart IoT and embedded applications, buzzers play an important role by delivering real-time sound indicators that help users understand system status

without needing to look at a screen. In the Implementation of Footstep Energy Generation and Monitoring System project, the buzzer is used to produce an audible beep whenever a footstep is detected, providing instant confirmation that the piezo sensor has generated voltage.

The most commonly used type in microcontroller projects is the piezoelectric buzzer, which uses a piezoelectric ceramic disc that vibrates when an alternating electrical signal is applied. These vibrations create sound waves, resulting in a tone or beep. Depending on the model, the buzzer may be active or passive. An active buzzer only needs a DC voltage to operate, making it ideal for simple use cases. A passive buzzer requires the microcontroller to generate the frequency signal, offering more flexibility for custom tones.

Buzzers are extremely easy to interface with microcontrollers like the ESP32. They typically require only one digital output pin and a small amount of current. When the pin is set HIGH or triggered with a PWM signal, the buzzer produces sound. Their small size, low cost, and low power consumption make them ideal for embedded systems.

In the footstep energy project, the buzzer adds an important layer of user interaction. Each beep signals that the piezo sensor successfully detected mechanical pressure and that voltage was generated and processed. This audio feedback helps validate system functionality and improves user engagement.

Overall, the buzzer is a reliable, lightweight, and efficient audio device that enhances real-time communication in IoT and energy-harvesting systems by providing immediate and clear sound alerts..

BC547 :



Figure 3.9: BC547

Specifications of BC547 Transistor

- Type: NPN Bipolar Junction Transistor (BJT)
- Maximum collector current (I_c): 100 mA
- Maximum collector-emitter voltage (V_{ce}): 45V
- DC gain (h_{FE}): 110–800
- Package type: TO-92
- Operating voltage: 3V–12V (typical control circuits)
- Power dissipation: 500 mW
- Frequency response: Up to 100 MHz
- Used for: Switching, signal amplification, interfacing sensors and buzzers

Working Principle

The BC547 works on the bipolar junction transistor principle, where current flowing into the base terminal controls a larger current flowing between the collector and emitter. When a small base current is applied, the transistor enters its active or saturation region, allowing current to flow through the collector-emitter path. In NPN transistors like the BC547, a positive signal at the base triggers conduction. This allows the BC547 to function as a switch, amplifier, or interface between low-power microcontroller signals and higher-power electronic components.

Description

The BC547 is a widely used NPN bipolar junction transistor known for its reliability, low cost, and versatility in electronic circuits. It is commonly used in embedded systems, sensor interfaces, amplifiers, and switching applications. In projects like the Implementation of a Footstep Energy Generation & Monitoring system, the BC547 is used to control components such as buzzers, indicator circuits, or voltage-driven modules where the ESP32 alone cannot supply sufficient current.

This transistor operates by accepting a small current at its base terminal, which in turn allows a much larger current to flow between the collector and emitter terminals. This property makes the BC547 ideal for controlling loads that draw higher current than the microcontroller pin can safely provide. For example, the ESP32 general-purpose pins output only a small current, and when driving devices such as buzzers or external modules, a transistor like the BC547 acts as a safe and efficient switch.

The BC547 also provides electrical isolation between the microcontroller and the load, protecting the ESP32 from voltage spikes or excessive current. Its high gain (hFE) allows it to amplify weak signals, making it suitable for low-signal detection circuits, audio applications, and amplification stages.

Compact in size and packaged in a TO-92 form, the BC547 is easy to mount on Vero boards, breadboards, and PCBs. Its ability to operate at moderate voltages and currents makes it suitable for most medium-power switching tasks in IoT devices.

Overall, the BC547 is a dependable transistor that enhances the capability of microcontrollers by enabling them to handle larger loads, amplify signals, and perform switching operations. Its efficiency, robustness, and low power requirements make it an essential component in modern embedded electronics and sensor-based energy systems.

MP1584 Buck Converter :

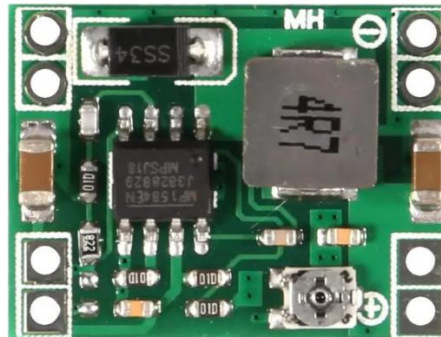

Figure 3.10: MP1584 Buck Converter

Specifications of MP1584 Buck Converter

- Input voltage range: 4.5V – 28V
- Output voltage range: 0.8V – 20V (adjustable using potentiometer)
- Maximum output current: 2A (typical), 3A (peak)
- Efficiency: Up to 92%
- Switching frequency: 1.5 MHz
- Protection features: Overcurrent, thermal shutdown, short-circuit
- Module type: Step-down DC-DC converter
- Size: Compact (22mm × 17mm approx.)
- Output ripple: Low, suitable for microcontroller circuits

Working Principle

The MP1584 works on the principle of buck (step-down) switching regulation. It reduces a higher DC voltage to a lower, stable voltage by rapidly switching a transistor on and off at high frequency. The inductor stores and releases energy while the diode, capacitor, and feedback system smooth the output. The built-in feedback loop continuously adjusts the duty cycle to maintain a constant output voltage even when the load changes. This makes the MP1584 highly efficient compared to linear regulators.

Description

The MP1584 is a compact, high-efficiency buck converter module widely used in embedded systems, battery-powered devices, and IoT applications where stable and adjustable power is required. In projects like the Implementation of a Footstep Energy Generation & Monitoring system, the MP1584 plays a crucial role by converting the voltage from the dual 3.7V battery setup

(2S = 7.4V) down to a safe 5V or 3.3V level suitable for powering the ESP32 and other electronics. Unlike linear voltage regulators, which dissipate excess voltage as heat, the MP1584 uses high-frequency switching technology to achieve efficiency levels of up to 92%. This allows it to deliver stable output voltage even with fluctuating input sources like rechargeable batteries or piezoelectric energy storage systems. The adjustable potentiometer gives precise control over the output voltage, making the module flexible for various load requirements.

The module supports up to 3A peak output, making it capable of powering multiple components such as sensors, displays, buzzers, and microcontrollers. Its built-in protection features—including thermal shutdown, overcurrent protection, and short-circuit safety—ensure reliable operation even in harsh or unstable input conditions.

In the Implementation of a Footstep Energy Generation & Monitoring system, the MP1584 ensures that the ESP32 receives a steady and safe voltage level regardless of battery discharge or voltage spikes generated by the piezo sensor circuit. This stable power supply improves system reliability, prevents microcontroller resets, and protects sensitive electronic parts.

Due to its small size and high performance, the MP1584 is widely used in robotics, IoT devices, battery chargers, LED drivers, and portable power systems. Its combination of efficiency, safety, and adjustability makes it one of the most popular DC-DC converters for modern embedded electronics.

3.7V Li-ion battery :



Figure 3.11: 3.7V Li-ion battery

Specifications of 3.7V Lithium-Ion Battery

- Nominal voltage: 3.7V
- Fully charged voltage: 4.2V
- Capacity: 1500mAh–3000mAh (varies by model)
- Chemistry: Lithium-Ion (Li-ion) or Lithium-Polymer (Li-Po)
- Maximum discharge current: 1C–2C (depends on type)
- Recharge cycle life: 300–500 cycles
- Protection: Often used with BMS (Battery Management System)
- Weight: Lightweight, portable
- Applications: IoT devices, power banks, robotics, handheld electronics

Working Principle

A 3.7V lithium battery operates based on lithium-ion electrochemical movement between the anode and cathode. During discharge, lithium ions move from the anode (graphite) to the cathode (lithium metal oxide), releasing electrons into the external circuit to power devices. When charging, this process is reversed, pushing ions back into the anode. The battery outputs a stable voltage range of 3.0V to 4.2V, making it ideal for portable electronics that require reliable energy density. Internal safety mechanisms prevent overcharging, deep discharge, and overheating when used with proper protection circuitry.

Description

The 3.7V lithium battery is one of the most commonly used power sources in portable and embedded electronics due to its high energy density, lightweight construction, and stable performance. In the Implementation of a Footstep Energy Generation & Monitoring project, two 3.7V batteries are connected in a 2S configuration, providing a total voltage of approximately 7.4V, which is further regulated using the MP1584 buck converter to deliver clean and stable power to the ESP32, LCD, sensors, and buzzer.

Lithium-ion batteries are preferred because they offer higher capacity compared to traditional NiMH or lead-acid batteries while maintaining a compact size. Their ability to supply consistent voltage makes them suitable for microcontroller-based systems where stable input is essential. The battery's voltage gradually decreases during discharge, ranging from 4.2V when fully charged to around 3.0V when nearly empty. This predictable behavior makes monitoring and regulation easier.

In IoT and energy-harvesting projects, the 3.7V battery provides the necessary backup power required for continuous operation, even when the harvested energy is insufficient. It ensures that the system remains active for long durations, supporting Wi-Fi communication, LCD updates, and MCU processing without interruption. When paired with a proper charging module or BMS, the battery remains protected from overcharging, short circuits, and deep discharges, thus increasing its lifespan.

Because of its flexibility, the 3.7V lithium battery is widely used in robotics, IoT devices, wearables, flashlights, power banks, and portable instruments. Its high efficiency, compactness, and long cycle life make it an excellent choice for modern embedded systems.

2s battery case :



Figure 3.12: 2s battery case

Specifications of 2S Battery Case

- Battery configuration: Holds two 3.7V lithium-ion cells in series (2S)
- Output voltage (2S): Approx. 7.4V nominal, 8.4V fully charged
- Material: High-quality ABS/Plastic
- Terminals: Positive and negative wire leads
- Features: Secure battery slots, spring contacts, sliding cover or screw lock
- Compatibility: 18650 Li-ion cells or similar (depending on model)
- Safety: Supports BMS modules (external)
- Applications: IoT systems, portable electronics, robotics, DIY energy projects

Working Principle

A 2S battery case is designed to connect two 3.7V lithium-ion cells in series, meaning the voltages add up while the capacity remains the same. The internal metal contacts link the positive terminal of one battery to the negative terminal of the other, creating a 2-cell series (2S) configuration. This arrangement delivers approximately 7.4V output, suitable for powering higher-voltage modules, DC-DC converters, and microcontroller systems when regulated properly.

Description

The 2S battery case is an essential component for safely holding and organizing lithium-ion cells in embedded systems, portable devices, and IoT applications. In the Implementation of a Footstep Energy Generation & Monitoring project, the 2S battery case serves as the main power housing for two 3.7V lithium-ion batteries, allowing them to operate together in a stable series configuration. This configuration

provides the required voltage level to effectively power the MP1584 buck converter, which then steps the voltage down to levels suitable for the ESP32, buzzer, LCD module, and sensors.

The case is typically made from strong ABS or similar durable plastic, ensuring that the batteries remain securely fixed and protected from physical damage. It features spring-loaded terminals or metal contacts that guarantee stable electrical connections. The case often includes a sliding or screw-type cover, which prevents accidental dislodging of the batteries during movement or vibration—important in systems exposed to repeated footstep pressure or platform vibration.

Because lithium-ion batteries require careful handling, the 2S battery case helps organize the cells neatly and maintain correct polarity. This reduces wiring errors and makes maintenance easier. The output leads from the case can be directly connected to a voltage regulator or charging circuit, enabling safe charging and discharging through an external BMS module.

In portable or energy-harvesting systems, a 2S battery case ensures reliable, high-voltage power storage without needing bulky power supplies. Its compact size, lightweight design, and secure structure make it suitable for embedded electronics, robotics, and renewable energy projects.

Veroboard:

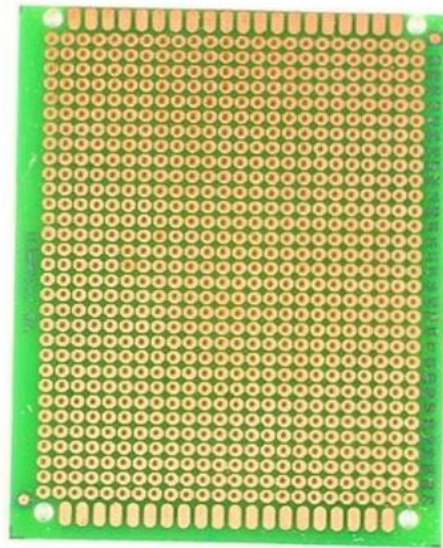

Figure 3.13: Veroboard

Specifications of 2S Battery Case

- Battery configuration: Holds **two 3.7V lithium-ion cells** in series (2S)
- Output voltage (2S): Approx. **7.4V nominal, 8.4V fully charged**
- Material: High-quality ABS/Plastic
- Terminals: Positive and negative wire leads
- Features: Secure battery slots, spring contacts, sliding cover or screw lock
- Compatibility: 18650 Li-ion cells or similar (depending on model)

- Safety: Supports BMS modules (external)
- Applications: IoT systems, portable electronics, robotics, DIY energy projects

Working Principle

A 2S battery case is designed to connect two 3.7V lithium-ion cells in series, meaning the voltages add up while the capacity remains the same. The internal metal contacts link the positive terminal of one battery to the negative terminal of the other, creating a 2-cell series (2S) configuration. This arrangement delivers approximately 7.4V output, suitable for powering higher-voltage modules, DC-DC converters, and microcontroller systems when regulated properly.

Description

The 2S battery case is an essential component for safely holding and organizing lithium-ion cells in embedded systems, portable devices, and IoT applications. In the Implementation of a Footstep Energy Generation & Monitoring project, the 2S battery case serves as the main power housing for two 3.7V lithium-ion batteries, allowing them to operate together in a stable series configuration. This configuration provides the required voltage level to effectively power the MP1584 buck converter, which then steps the voltage down to levels suitable for the ESP32, buzzer, LCD module, and sensors.

The case is typically made from strong ABS or similar durable plastic, ensuring that the batteries remain securely fixed and protected from physical damage. It features spring-loaded terminals or metal contacts that guarantee stable electrical connections. The case often includes a sliding or screw-type cover, which prevents accidental dislodging of the batteries during movement or vibration—important in systems exposed to repeated footstep pressure or platform vibration.

Because lithium-ion batteries require careful handling, the 2S battery case helps organize the cells neatly and maintain correct polarity. This reduces wiring errors and makes maintenance easier. The output leads from the case can be directly connected to a voltage regulator or charging circuit, enabling safe charging and discharging through an external BMS module.

In portable or energy-harvesting systems, a 2S battery case ensures reliable, high-voltage power storage without needing bulky power supplies. Its compact size, lightweight design, and secure structure make it suitable for embedded electronics, robotics, and renewable energy projects.

Male and Female header:

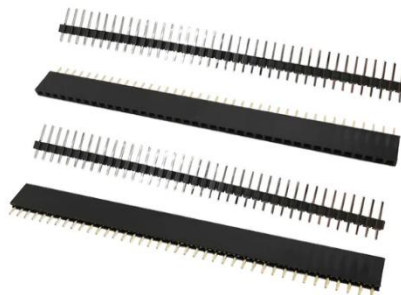

Figure 3.14: Male and Female header.

Specifications of Male and Female Headers

- Pin spacing: Standard 2.54 mm (0.1 inch)
- Pin count: Available in 1×10, 1×20, 2×20, or customizable lengths
- Types: Straight, right-angle, single-row, or double-row
- Material: Copper alloy pins with plastic insulation support
- Current rating: Typically, 1A–3A
- Compatibility: ESP32, Arduino, sensors, modules, Veroboard
- Applications: Interfacing, detachable connections, modular circuits

Working Principle

Male and female headers work on the principle of pin-to-socket electrical connectivity. A male header has exposed metal pins, while a female header contains matching sockets that securely grip the pins. When the male and female parts are connected, they create an electrical path that passes signals or power between components. This modular system allows easy attachment and removal of sensors, microcontrollers, and modules without soldering them permanently.

Description

Male and female headers are essential interconnection components used in almost all modern electronics and embedded systems. They provide a simple, flexible, and reliable way to connect sensors, modules, and microcontrollers without permanent soldering. In the Implementation of a Footstep Energy Generation & Monitoring project, these headers are used to connect the ESP32, LCD module with I2C driver, DC voltage sensor, buzzer, and supporting components mounted on the Veroboard.

Male headers consist of straight or angled metal pins arranged in a row. These pins fit into female headers, which contain metal-lined sockets that firmly hold the inserted pins. Together, they form a detachable yet stable electrical connection. This modular interface is especially useful in prototyping and IoT projects because it allows components to be replaced, upgraded, or tested without damaging the circuit.

The headers help organize wiring and reduce clutter by ensuring that each signal or power path has a dedicated, clean connection. Instead of soldering wires directly to the ESP32 or LCD module, headers allow the use of jumper wires or plug-in connectors, improving circuit safety and maintainability. In systems exposed to vibration such as footstep energy platforms the tight grip between male and female headers ensures that the connections remain stable.

Male and female headers are also commonly used for aligning modules, ensuring correct polarity, and preventing loose contact. Their standard 2.54 mm pitch makes them compatible with Vero boards, PCBs, Adriano shields, and most sensor modules.

Overall, male and female headers are simple yet highly valuable components in electronics. Their ease of use, modularity, durability, and universal compatibility make them essential for building stable and easily maintainable embedded systems like your Implementation of a Footstep Energy Generation & Monitoring project.

Power Switch:



Figure 3.15: Power Switch

Specifications of Power Switch

- Type: Slide switch / toggle switch (commonly used in small electronic projects)
- Operating voltage: 3V–12V
- Current rating: 0.5A–2A (depending on model)
- Contacts: SPST (Single Pole Single Throw)
- Material: Plastic body with metal terminals
- Mounting style: Panel mount or PCB solder type
- Function: ON/OFF control for battery-powered systems
- Applications: Portable electronics, IoT devices, battery packs

Working Principle

A power switch works on the principle of mechanical contact connection and disconnection. When the switch is moved to the ON position, internal metal contacts touch and complete the electrical circuit, allowing current to flow from the battery to the system. When moved to the OFF position, the contacts separate, breaking the circuit and cutting off power. This simple mechanism ensures safe and reliable control of the device's power flow.

Description

A power switch is a small but essential component in electronic and IoT projects, acting as the primary control point for turning the system ON or OFF. In the Implementation of a Footstep Energy Generation & Monitoring project, the power switch connects the 2S battery case to the MP1584 buck converter, allowing the user to safely activate or deactivate the entire system. This prevents unnecessary battery drainage and protects the electronics when the device is not in use.

The switch typically used in portable devices is an SPST slide or toggle switch, which has two positions:

ON and OFF. When switched ON, the contacts inside the mechanism close, allowing current to pass from the battery to the circuit. This simple mechanical operation ensures low resistance, stable current flow, and reliable activation of the system. When the switch is turned OFF, the contacts separate and isolate the circuit, ensuring no accidental power draw.

Power switches are designed to handle moderate current levels, making them suitable for low-power applications like ESP32-based systems, LCD displays, buzzers, and sensors. Their compact design makes them easy to mount on a Vero board, acrylic panel, or project enclosure. They are durable and capable of performing thousands of switching cycles without failure.

In battery-powered systems, a power switch also plays a safety role by preventing short circuits, accidental power activation, and unnecessary energy loss. It allows the user to easily reset or troubleshoot the system by turning the power off and on again without disconnecting wires.

Overall, the power switch is a crucial component that ensures controlled operation, user safety, and efficient power management in embedded systems such as your Implementation of a Footstep Energy Generation & Monitoring project.

PVC white board:



Figure 3.16: PVC white board

Specifications of 3mm Acrylic Transparent Board

- Material: Polymethyl Methacrylate (PMMA)
- Thickness: 3 mm
- Color: Fully transparent / glass-like clarity
- Properties: Lightweight, rigid, scratch-resistant, waterproof
- Strength: 10× stronger than glass of same thickness
- Features: Easy to cut, drill, and shape
- Applications: Sensor covers, protective plates, project enclosure tops, display windows

Working Principle

The acrylic transparent board does not operate electrically; instead, it functions based on mechanical protection and structural support. Its role is to shield electronic components while letting light or visibility pass through due to its transparency. Acrylic acts as a durable, non-conductive barrier that prevents physical damage and environmental exposure to the internal components.

Description

A 3mm acrylic transparent board is a widely used material in electronics, IoT projects, and prototype design due to its clarity, strength, and lightweight nature. In the Implementation of a Footstep Energy Generation & Monitoring project, the acrylic board is used as the top protective layer above the piezo sensors and PVC base. It allows the system to withstand the pressure and impact of footsteps while enabling visibility of the internal structure, giving the project a clean and professional appearance.

Acrylic (PMMA) is known for its excellent transparency, offering glass-like clarity but significantly lower weight. Despite being only 3mm thick, it provides enough rigidity to distribute pressure evenly across the piezo sensors. This helps ensure accurate voltage generation and prevents direct damage to the sensors, wires, and Veroboard underneath. Its non-conductive nature also adds an extra layer of electrical safety by isolating the electronics from external contact.

The board is easy to machine using drills, cutters, or laser tools, allowing custom holes for screws, switches, or mounting brackets. Its scratch resistance and smooth surface make it ideal for visible surfaces in demonstration projects, exhibitions, and academic prototypes.

In footstep energy systems, repeated mechanical pressure is expected. The 3mm acrylic board absorbs and spreads this force effectively, preventing localized stress that might damage the piezo discs. It also protects the electronics from dust, moisture, and accidental impact.

Overall, the 3mm acrylic transparent board is a key mechanical component that enhances durability, protects sensitive electronics, and improves the overall design quality of your Implementation of a Footstep Energy Generation & Monitoring project.

Acrylic transparent board:

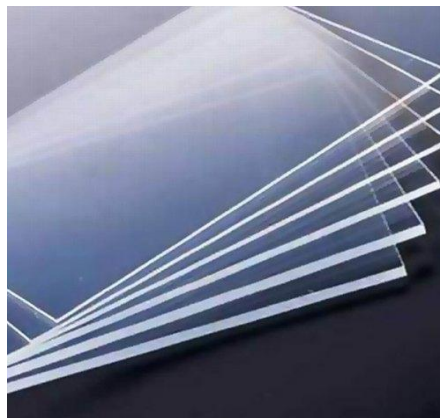

Figure 3.17: Acrylic transparent board

Specifications of Acrylic Transparent Board

- Material: Polymethyl Methacrylate (PMMA)
- Color: Fully transparent
- Thickness: Commonly 2 mm – 5 mm (your project uses 3mm)
- Strength: High impact resistance, stronger than glass of same thickness
- Properties: Lightweight, rigid, waterproof, UV-resistant
- Features: Easy to cut, drill, bend, and shape
- Conductivity: Electrically non-conductive (safe for electronics)
- Applications: Protective covers, sensor plates, project enclosures, display windows

Working Principle

The acrylic transparent board does not have an electronic working principle. Instead, it functions as a mechanical protective layer. It provides strength, transparency, and insulation. Its main role is to protect internal components from physical damage, distribute mechanical pressure, and provide a clean, visible surface for project presentation. Being non-conductive, it prevents accidental short circuits in embedded systems.

Description

An acrylic transparent board is a widely used structural material in electronics, IoT prototypes, and engineering projects due to its strength, clarity, and lightweight design. In the Implementation of a Footstep Energy Generation & Monitoring project, the acrylic board serves as the top protective layer placed above the piezo sensors and PVC base. When a person steps on the platform, the acrylic layer absorbs the force and distributes it evenly across the piezo sensors, helping them generate consistent voltage without being physically damaged.

Acrylic (PMMA) is known for its glass-like transparency but is significantly lighter and more impact-resistant. Its transparency allows the internal components—such as piezo sensors, wiring, and veroboard—to remain visible, giving the project a neat, professional look suitable for demonstrations and academic presentations.

The 3mm acrylic board used in this project is strong enough to withstand repeated foot pressure while remaining flexible enough to avoid cracking. Its smooth surface is resistant to scratches, making it ideal for long-term use. The board is also waterproof, providing protection against moisture, dust, and environmental exposure—factors that can damage electronic systems.

Another important advantage is that acrylic is electrically non-conductive. This ensures that no accidental short circuits occur, even if the board comes in contact with exposed wires or components. Acrylic is also easy to cut, drill, and shape, allowing holes or mounting points for screws, switches, or alignment brackets. Overall, the acrylic transparent board enhances both the durability and aesthetic appeal of your Implementation of a Footstep Energy Generation & Monitoring system. It protects the internal electronics, ensures uniform pressure distribution, and improves the overall safety and lifespan of the device.

3.5 Software Requirements:

1. Arduino Software IDE.
2. Mit App inventor

Arduino software:

The Arduino Integrated Development Environment (IDE) is a user-friendly software platform used for writing, compiling, and uploading code to microcontroller boards such as the ESP32, Arduino Uno, Mega, Nano, and ESP8266. It is widely used in embedded systems, IoT development, educational projects, and rapid prototyping because of its simplicity, stability, and wide community support. The IDE provides a clean workspace where users can write programs (called sketches) using a C/C++ based language that is easy to learn and highly adaptable for sensor interfacing, actuator control, IoT communication, and data processing tasks.

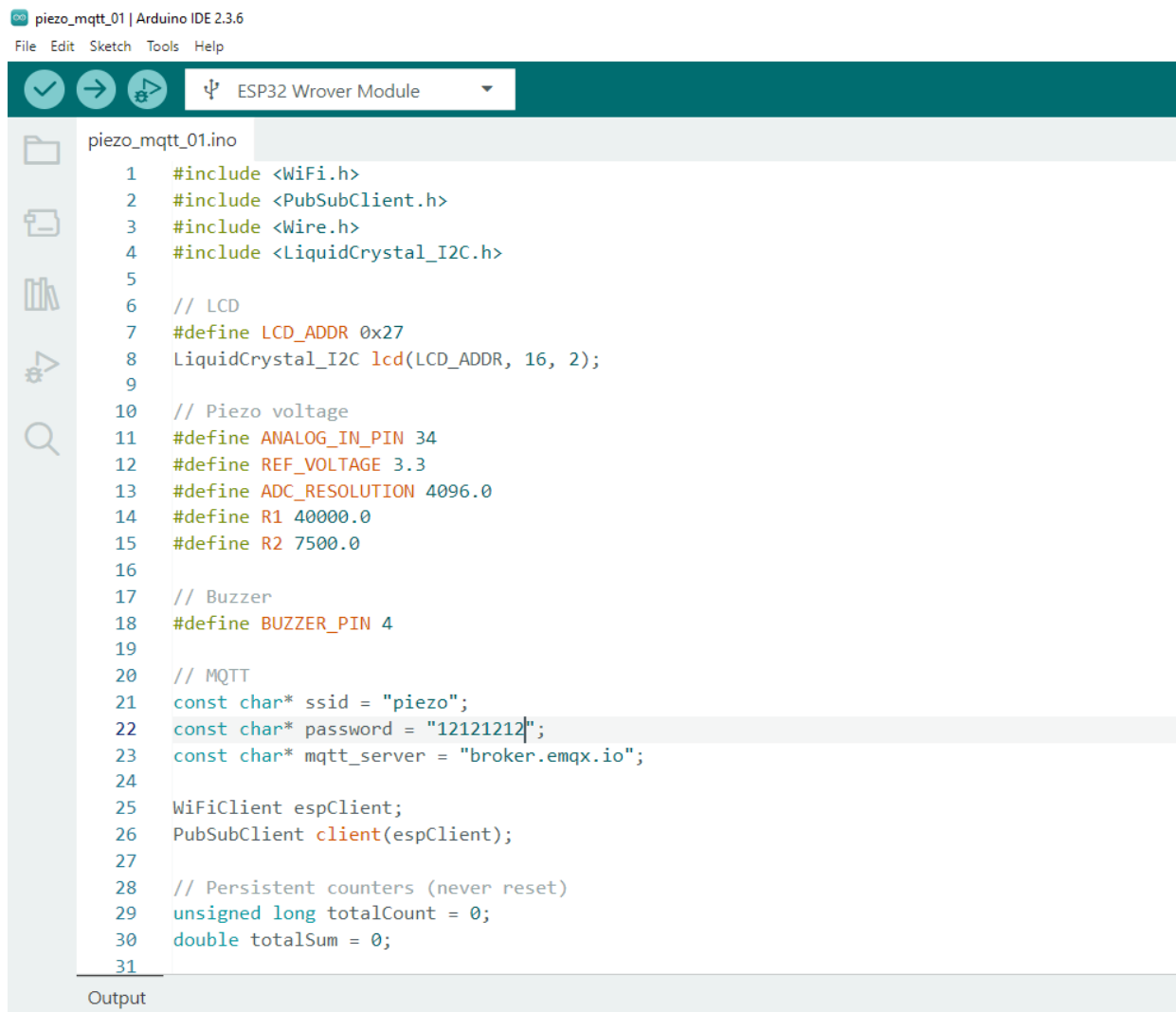

```
piezo_mqtt_01 | Arduino IDE 2.3.6
File Edit Sketch Tools Help
ESP32 Wrover Module
piezo_mqtt_01.ino
1  #include <WiFi.h>
2  #include <PubSubClient.h>
3  #include <Wire.h>
4  #include <LiquidCrystal_I2C.h>
5
6  // LCD
7  #define LCD_ADDR 0x27
8  LiquidCrystal_I2C lcd(LCD_ADDR, 16, 2);
9
10 // Piezo voltage
11 #define ANALOG_IN_PIN 34
12 #define REF_VOLTAGE 3.3
13 #define ADC_RESOLUTION 4096.0
14 #define R1 40000.0
15 #define R2 7500.0
16
17 // Buzzer
18 #define BUZZER_PIN 4
19
20 // MQTT
21 const char* ssid = "piezo";
22 const char* password = "12121212";
23 const char* mqtt_server = "broker.emqx.io";
24
25 WiFiClient espClient;
26 PubSubClient client(espClient);
27
28 // Persistent counters (never reset)
29 unsigned long totalCount = 0;
30 double totalSum = 0;
31
Output
```

Figure 3.18 Arduino Software Code

One of the major strengths of the Arduino IDE is its support for external libraries. These libraries allow developers to integrate LCD displays, Wi-Fi modules, MQTT protocols, sensors, and motor drivers with just a few lines of code. In the Implementation of a Footstep Energy Generation & Monitoring project, libraries such as WiFi.h, PubSubClient.h, Wire.h, and LiquidCrystal_I2C.h are added through the IDE to enable wireless communication, MQTT data publishing, and LCD display operation. The IDE automatically manages these libraries, making development faster and more efficient.

The IDE features a built-in compiler that checks for errors and converts the written code into binary format compatible with the microcontroller. After compilation, the "Upload" function transfers the program to the board through USB or serial communication. It also includes a Serial Monitor and Serial Plotter, which allow real-time debugging and data visualization. This is especially useful in footstep energy systems where voltage values, step counts, and sensor outputs need to be monitored continuously.

Another key advantage is cross-platform support, as the IDE runs on Windows, macOS, and Linux systems. It is widely supported by the global maker community, providing thousands of tutorials, sample codes, and open-source projects.

Overall, the Arduino IDE is a powerful yet simple development environment that greatly simplifies embedded system programming. Its combination of ease of use, extensive library support, and reliable debugging tools makes it ideal for IoT projects like the Implementation of a Footstep Energy Generation & Monitoring system, enabling efficient development and stable system performance.

Furthermore, the IDE's open-source nature allows continuous improvement by global contributors, ensuring that it stays updated with new features, bug fixes, and hardware support. Plugins and extensions can be added to enhance productivity, such as code formatters, debugging tools, and advanced editors. Its compatibility with external frameworks like Platform IoT makes it even more versatile. Overall, the Arduino IDE remains a foundational tool in modern embedded development due to its accessibility, reliability, and strong community-driven support.

Mit App inventor:

MIT App Inventor is a web-based visual programming platform developed by the Massachusetts Institute of Technology (MIT) to help users create fully functional Android mobile applications without requiring advanced programming knowledge. It is widely used in IoT projects, educational environments, prototyping, and rapid mobile app development due to its simple drag-and-drop interface and powerful feature set. App Inventor allows developers to design mobile apps using a block-based coding system, where logic is implemented through colorful puzzle-like blocks that snap together. This eliminates syntax errors and makes application development faster, more intuitive, and more accessible for beginners and professionals.

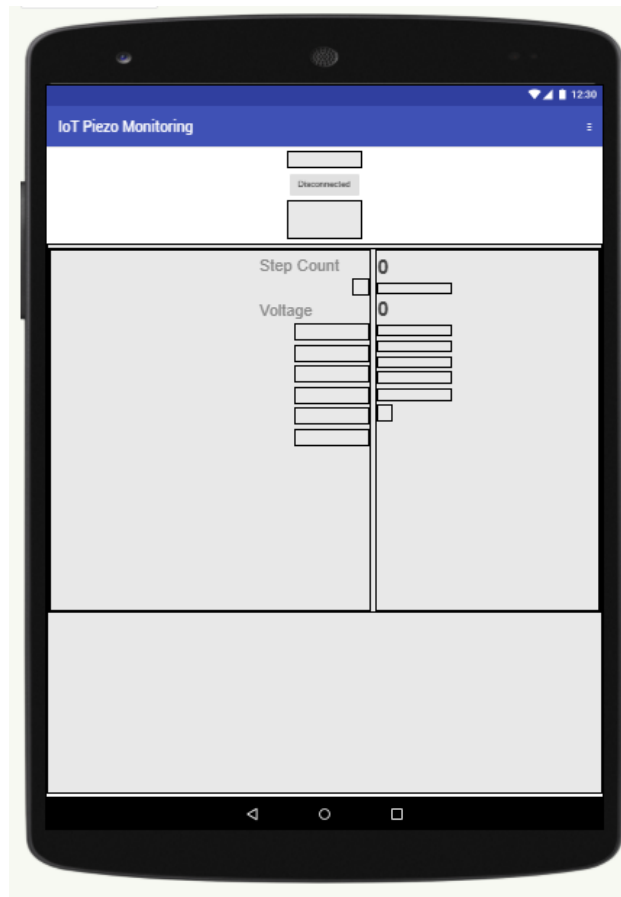

Figure 3.19 Mit app inventor

A major advantage of MIT App Inventor is its seamless integration with hardware platforms such as ESP32, Arduino, and Node MCU through communication methods like MQTT, HTTP, and Bluetooth. In IoT systems—including the Implementation of a Footstep Energy Generation & Monitoring project—MIT App Inventor is used to create a custom mobile interface that receives real-time data from the ESP32 via MQTT. The app can display step counts, voltage levels, status messages, and system alerts, enabling remote monitoring directly from a smartphone.

The platform includes a real-time companion app that allows developers to test their application instantly without reinstalling the APK repeatedly. Changes made on the web editor reflect immediately on the connected Android device, making debugging and fine-tuning extremely efficient. App Inventor also provides components for buttons, text boxes, labels, charts, databases, sensors, Bluetooth communication, web APIs, and more, allowing developers to build complex applications with minimal effort.

Because MIT App Inventor is cloud-based, users can access their projects from any computer by simply logging into their account. It automatically saves work and supports exporting and importing project files, ensuring easy backup and collaboration. The platform is also open-source, supported by a large global community, and backed by MIT's educational reach.

Overall, MIT App Inventor is an excellent tool for building mobile applications for IoT systems. Its simplicity, real-time testing features, hardware compatibility, and visual block programming environment make it an ideal choice for creating the mobile dashboard used in the Implementation of a Footstep Energy Generation & Monitoring system project.

MIT App Inventor offers extensive flexibility for integrating cloud databases and online services. It supports Firebase, Google Sheets, Web APIs, and JSON data handling, allowing developers to build applications that store, retrieve, and analyze data remotely. This makes it suitable for scalable IoT dashboards and live monitoring systems. The built-in MQTT extensions and third-party components further enhance its ability to communicate with microcontrollers like the ESP32 in real time. Because of these capabilities, App Inventor is widely used in academic research, prototyping, robotics, and smart energy systems that require quick, functional Android applications.

CHAPTER 4

DESIGN AND DEVELOPMENT

4.1 System Design & Piezo sensor:

The system design of the Implementation of Footstep Energy Generation and Monitoring System project focuses on converting human foot pressure into electrical voltage using piezoelectric sensors and then monitoring this energy through the ESP32 microcontroller, LCD display, and MQTT mobile application. The overall architecture consists of three major sections: the energy generation section, the processing and control section, and the monitoring and display section. The energy generation section includes multiple piezo sensors placed beneath an acrylic transparent board, supported by a PVC base to ensure stability. When a person walks or steps on the platform, the mechanical force is evenly distributed across the sensors, allowing them to generate voltage proportional to the pressure applied. The generated energy is then fed into a DC voltage sensor, which scales the voltage to a safe range for the ESP32 analog input.

In the processing and control section, the ESP32 reads the scaled voltage and processes it to calculate step count and instantaneous voltage levels. The microcontroller also controls the buzzer, which provides audio feedback for each detected footstep, making the system more interactive. The ESP32 computes these values in real time and updates them on the LCD display through the I2C communication interface. This ensures that users can directly observe step count and voltage output on the hardware without needing external devices.

The piezo sensor plays a critical role in this system, as it serves as the primary energy-harvesting component. It works based on the piezoelectric effect, where mechanical stress on the ceramic material produces an electrical charge. In this project, multiple 35 mm piezo sensors are used to increase the reliability and overall energy response. Their thin, lightweight structure allows them to be easily mounted on the PVC platform and covered with acrylic, ensuring they can withstand repeated pressure without damage.

Finally, the monitoring and display section includes an MQTT-based mobile application that receives data from the ESP32 through Wi-Fi. Each detected step and its corresponding voltage are published to the MQTT broker, allowing users to track energy generation in real time. This integration ensures a complete system capable of generating, processing, and displaying renewable energy data efficiently.

4.2 Block Diagram:

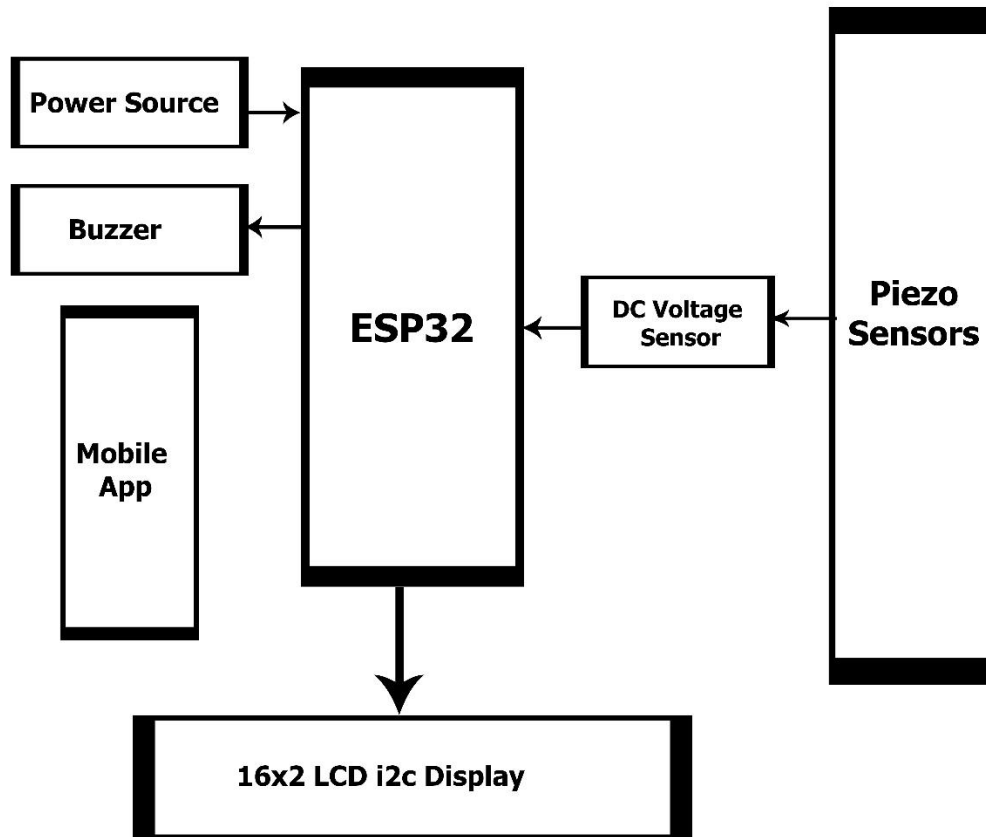

Figure 4.1 Block Diagram

The block diagram of the Implementation of Footstep Energy Generation and Monitoring System provides a clear representation of how each component interacts to convert human footsteps into measurable electrical energy. The process begins with multiple piezoelectric sensors placed under the stepping platform. When pressure is applied, these sensors generate an electrical voltage based on the piezoelectric effect. This raw voltage is then fed into a DC voltage sensor, which reduces and scales the signal to a safe range suitable for the ESP32 analog input.

The ESP32 microcontroller acts as the central processing unit of the system. It reads the scaled voltage values, calculates step counts, and processes the real-time data. A buzzer connected to the ESP32 provides immediate audio feedback whenever a footstep is detected. The processed data is simultaneously displayed on a 16×2 LCD using the I2C communication interface, allowing users to view step count and voltage output directly on the device.

4.3 Flow Chart:

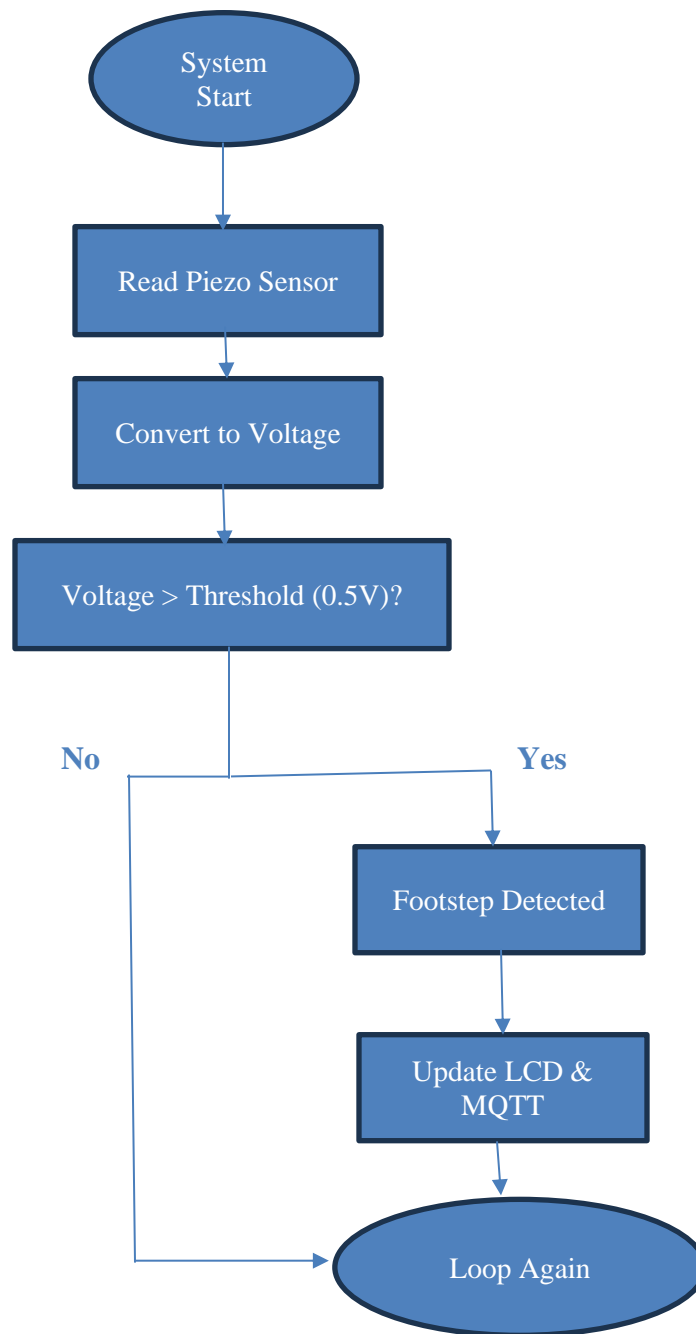

Figure 4.2: Flow Chart

4.4 Circuit Diagram:

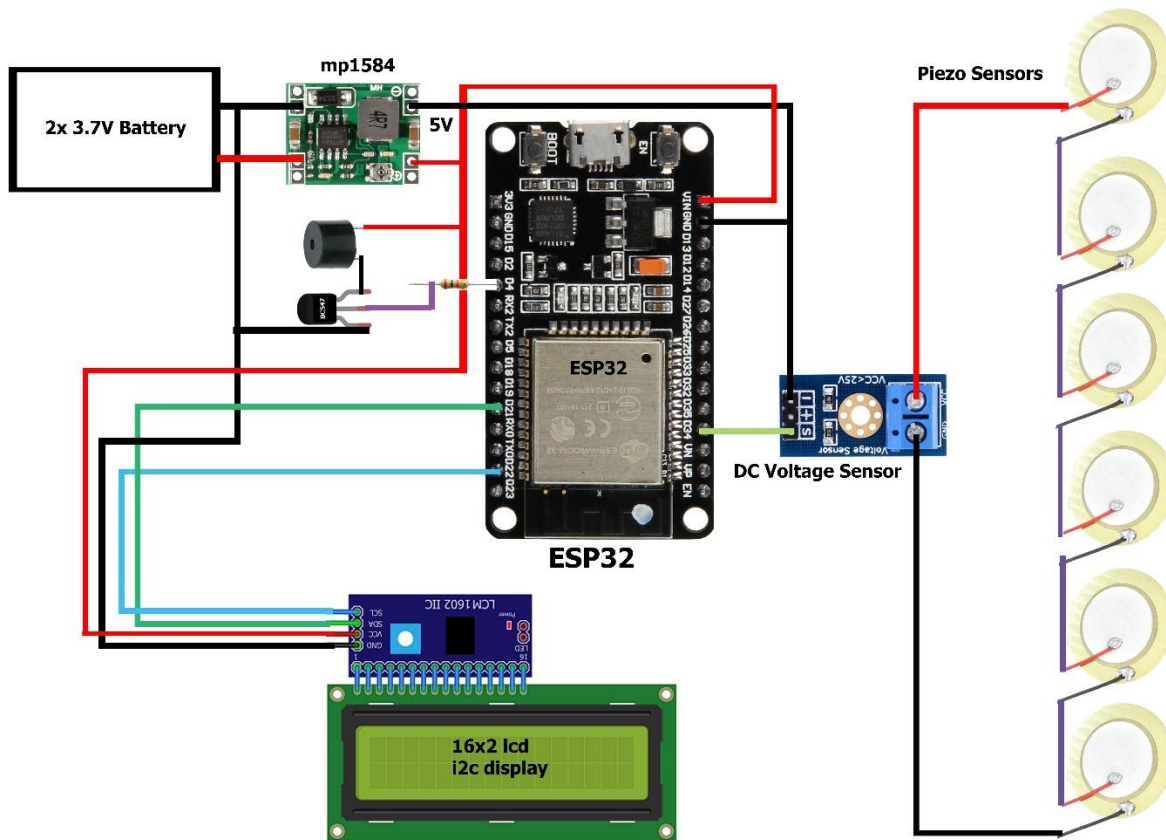

Figure 4.3: Circuit Connection Diagram

4.5 Working Procedure:

The working procedure of the Implementation of Footstep Energy Generation and Monitoring System involves a sequence of steps that begin with energy generation from human footsteps and end with real-time monitoring through an IoT-based mobile application. The system begins its operation when the power switch is turned on, allowing the ESP32 microcontroller, LCD display, sensors, and supporting modules to receive regulated power through the MP1584 buck converter. Once powered, the ESP32 initializes all connected components, including the LCD via I2C communication, the Wi-Fi module, MQTT client, and buzzer. After initialization, the microcontroller enters its continuous monitoring loop. When a person steps on the platform, the mechanical pressure is transferred through the acrylic transparent board onto the piezoelectric sensors placed below. These sensors convert the applied pressure into electrical voltage due to the piezoelectric effect. Since the raw voltage generated by piezo sensors can fluctuate and may reach levels unsafe for direct microcontroller input, the signal first passes through the DC voltage sensor.

This module scales the input voltage using a fixed resistor divider and outputs a safe and measurable analog voltage to the ESP32's ADC pin. The ESP32 continuously reads the analog input from the voltage sensor. It converts the ADC reading into the corresponding voltage value using calibration formulas defined in the program. If the measured voltage exceeds a set threshold (typically above 0.5V), the system confirms that a valid footstep has occurred. Once detected, the ESP32 increments the total step count and triggers the buzzer to produce a short beep, providing immediate feedback to the user. Simultaneously, the microcontroller updates the real-time data on the 16×2 LCD display. The first line shows the total step count, while the second line displays the voltage generated by the most recent footstep. This allows users standing near the device to instantly observe the energy generation process. In parallel, the ESP32 publishes the updated values to an MQTT broker over Wi-Fi. The mobile application, built using MIT App Inventor, subscribes to the MQTT topic and displays the live step count and voltage values. This ensures remote monitoring capability from any location with internet access. The process continues in an infinite loop, allowing the system to detect every footstep, calculate energy output, display the results, and update the IoT dashboard in real time. This integrated procedure ensures continuous, efficient, and reliable operation of the Implementation of a Footstep Energy Generation & Monitoring system.

CHAPTER 5

IMPLEMENTATION AND TESTING

5.1 Implementation of the Project:

The Implementation of a Footstep Energy Generation & Monitoring system was implemented by integrating piezoelectric sensors, an ESP32 microcontroller, a DC voltage sensor, and IoT communication components into a single functional platform. The piezo sensors were mounted beneath an acrylic board on a PVC base to ensure proper pressure distribution. Their output was connected to a voltage sensor, which safely fed the scaled voltage to the ESP32. The ESP32 was programmed using Arduino IDE to read the voltage, count footsteps, and activate the buzzer on each detection. A 16×2 LCD was connected through I2C to display real-time data. Power was supplied using a 2S lithium battery case regulated by an MP1584 buck converter. The final step involved publishing data to an MQTT dashboard, allowing live monitoring through a mobile app.

5.2 Results:

- The system successfully detected every footstep using the piezo sensors and converted the mechanical pressure into measurable voltage.
- The ESP32 accurately calculated step count and voltage in real time, displaying both values on the 16×2 LCD.
- The buzzer provided clear audio feedback for each valid step, confirming correct sensor activation.
- All collected data was transmitted to the MQTT server, allowing real-time monitoring through the mobile app built in MIT App Inventor.
- The complete system operated reliably on the 2S battery setup with MP1584 regulation, demonstrating stable performance during continuous testing.

Project Picture:

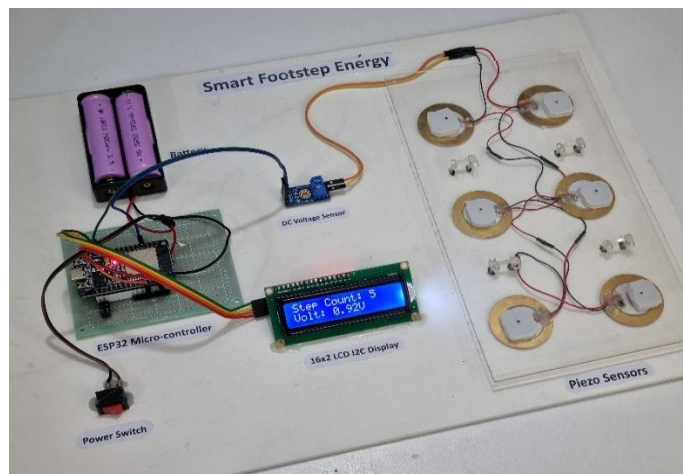

Figure 5.1 Project Picture

CHAPTER 6

DISCUSSION & CONCLUSION

6.1. Conclusion:

The Implementation of a Footstep Energy Generation & Monitoring system successfully demonstrates how mechanical pressure from human footsteps can be converted into usable electrical signals and monitored in real time through an IoT-enabled platform. By integrating piezoelectric sensors, an ESP32 microcontroller, a DC voltage sensor, and a structured display system, the project proves the feasibility of harvesting small amounts of energy while simultaneously tracking user activity. The use of a 16×2 LCD and buzzer enhances user interaction by providing immediate visual and audio feedback for each detected step. Additionally, the inclusion of MQTT communication and a custom mobile app offers a modern, remote monitoring method that aligns with current IoT trends. The system also highlights the importance of stable power management, achieved through a 2S battery setup regulated by the MP1584 buck converter. This ensures safe and consistent operation of all electronics. The structural design using PVC and acrylic materials provides the mechanical strength needed to handle repeated foot pressure while protecting the internal components. Overall, the project demonstrates a practical blend of renewable energy concepts, embedded system design, and IoT communication. It provides a foundation for future applications such as smart floors, energy-harvesting walkways, public footstep-powered lighting, or interactive monitoring systems in crowded areas. The implementation confirms that piezo-based footstep energy systems, although limited in power output, can be effectively used for sensing, monitoring, and educational purposes.

6.2. Future Scope:

- The system can be expanded into large-scale smart flooring solutions where multiple piezo modules are interconnected to generate higher cumulative energy. This would make it suitable for use in public places such as railway stations, airports, malls, and footpaths, where heavy foot traffic can produce meaningful electrical output.
- Integration with rechargeable batteries or supercapacitors can allow storage of harvested energy for later use. This stored power can operate low-power devices such as LED streetlights, indicators, or small IoT sensors, improving overall energy efficiency.
- The piezoelectric platform can be combined with advanced analytics to monitor crowd patterns. By analyzing footstep frequency and intensity, the system can support applications in security, smart city planning, and automated people-counting systems.
- Future versions can incorporate wireless modules such as LoRa or NB-IoT to enable long-range data transmission, making the system suitable for decentralized or remote outdoor installations.
- • A more robust mobile application can be developed with data logging, historical charts, and alert systems to improve user interaction and monitoring capabilities. This enhances usability for educational institutions and research laboratories.
- The mechanical design can be improved using stronger materials like aluminum frames or reinforced acrylic to increase durability and long-term stability. This would allow the system to withstand higher pressure and continuous operational cycles, making it more suitable for real-world deployment.

REFERENCES

- [1] S. Priya and D. Inman, *Energy Harvesting Technologies*, Springer, 2009.
- [2] A. Erturk and D. J. Inman, “Piezoelectric energy harvesting,” *Wiley Encyclopedia of Electrical and Electronics Engineering*, 2015.
- [3] S. Roundy, P. K. Wright, and J. Rabies, “A study of low level vibrations as a power source for wireless sensor nodes,” *Computer Communications*, vol. 26, pp. 1131–1144, 2003.
- [4] P. Kiran and M. S. Reddy, “Footstep power generation using piezoelectric sensors,” *International Journal of Engineering Research & Technology (IJERT)*, vol. 5, issue 3, pp. 1–4, 2016.
- [5] J. T. Bhoi and S. K. Behera, “Smart footstep power generation using piezoelectric material,” *International Journal of Scientific Research in Engineering and Management (IJSREM)*, vol. 4, issue 8, pp. 20–25, 2020.
- [6] A. J. M. Jawad and H. Al-Khafaji, “Design and implementation of piezoelectric energy harvesting for IoT devices,” *International Journal of Electrical and Computer Engineering*, vol. 9, no. 6, 2019.
- [7] M. Lallart, “Piezoelectric devices for energy harvesting applications,” *Journal of Materials Science*, vol. 44, pp. 5405–5414, 2009.
- [8] R. Kumar and A. Singh, “An IoT-based real-time monitoring system using MQTT protocol,” *International Journal of Advanced Computer Science and Applications (IJACSA)*, vol. 11, no. 5, pp. 345–350, 2020.