

Design and Performance Analysis of a Solar Based Battery Energy Storage System: A Case Study of a 110kW Solar power System at Marine Drive, Cox's Bazar.



SONARGAON UNIVERSITY (SU)

Supervised By

Md.Rais Uddin Mollah

Head

Electrical and Electronics Engineering
Sonargaon University (SU)

Submitted By

Md Ebrahim	EEE2201025091
Abdur Razzak	EEE2202026014
Chaity Sarkar	EEE2202026034
Sabik Ahammad	EEE2202026036
Md. Rafiqul	EEE2202026080

Department of Electrical and Electronic Engineering (EEE)

Sonargaon University (SU)

147/I, Panthapath, Dhaka-1225, Bangladesh

January 2026

Declaration

We certify that the Research based Thesis titled, “**Design and Performance Analysis of a Solar Based Battery Energy Storage System: A Case Study of a 110kW Solar power System at Marine Drive, Coks Bazar**” is completely our group work. All sources and knowledge for this paper that were found by other researchers are acknowledged by reference. Materials of work such as image, figures, tables and citations in this paper are accepted by our supervisor We hereby declare that this thesis has not been previously submitted either in whole or in part, for any other degree or publication.

.....
Md Ebrahim

.....
Abdur Razzak

.....
Chaity Sarkar

.....
Sabik Ahammad

.....
Md. Rafiqul

.....
Md.Rais Uddin Mollah
Head
Electrical and Electronics Engineering
Sonargaon University (SU)

Certification

This is to certify that this project entitled done by the following students under my direct supervision. This thesis work been carried out by them in the laboratories of the Department “**Design and Performance Analysis of a Solar Based Battery Energy Storage System: A Case Study of a 110kW Solar power System at Marine Drive, Coxs Bazar**” of Electrical and Electronic Engineering under the faculty of Engineering, Sonargaon university (SU) in partial fulfillment of the requirements for the degree of Bachelor of Science in Electrical and Electronic Engineering.

Supervisor

.....

Md.Rais Uddin Mollah
Head
Electrical and Electronics Engineering
Sonargaon University (SU)

Acknowledgement

First of all, we would like to say thanks to almighty "Allah" for giving us the strength to finish the project as a partial fulfillment for the requirements for the Degree of B. Sc. In Electrical and Electronic Engineering.

We would like to express our gratitude and appreciation to our supervisor, Md. Rais Uddin Mollah, Head, Department of Electrical and Electronic Engineering of Sonargaon University for the guidance and enthusiasm extended throughout the progress of this work.

We are also grateful to all the faculties of the Department of Electrical and Electronic Engineering of Sonargaon University, Bangladesh for giving us the opportunity to complete the work and necessary support during the period.

This thesis work would not have been possible without the encouragement, logical help and advice from our friends. We are grateful to them.

Finally, we must acknowledge with due respect the constant support and patience of our parents.

Table of Contents

Chapter 1

Introduction

Serial No	Topic	Page No
1.1	Introduction	9
1.2	Objective	10
1.3	Methodology	11
1.4	Literature review	11
1.5	Background and preliminaries	12

Chapter 2

Site Analysis & Resource Assessment

Serial No	Topic	Page No
2.1	Location	14
2.2	Solar Resource	14
2.3	Daily Average	14
2.4	Seasonal Differences	14
2.5	Environmental Challenges	14
2.6	Temperature Impact	14

Chapter 3

Design and Implementation

Serial No	Topic	Page No
3.1	Model	15
3.2	Battery Energy Storage System (BESS) MATLAB Simulink	15
3.3	Solar System Design (Pv Sol & Pv Syst)	16
3.4	Capacity Switching (Homer Pro)	17
3.5	Working Principle	19
3.6	List of Component	19

Chapter 4

Component Description

Serial No	Topic	Page No
4.1	Solar Panel System	20
4.2	Battery	20
4.3	Dc-Ac Inverter	21
4.4	Grid	22
4.5	Substation	22
4.6	Control Room	22
4.7	Loads	22
4.8	Pv Plant	23

Chapter 5

System Output

Serial No	Topic	Page No
5.1	Battery Energy Storage System (MATLAB)	24
5.2	Pv Syst Output	25
5.3	Pv Sol Output	26
5.4	Financial Analysis (Homer Pro)	28
5.5	Economic Analysis	30

Chapter 6

Advantages and Disadvantages

Serial No	Topic	Page No
6.1	Advantages	31
6.2	Disadvantages	31
6.3	Features	32
6.4	Key Specification	32
6.5	Applications	33

Chapter 7

Result & Discussion

Serial No	Topic	Page No
7.1	Result	34
7.2	Discussion	35
7.3	Conclusion	35

List of Figure

Figure	page
Figure: 3.1 Battery Energy Storage System (BESS)	15
Figure: 3.2 Solar System Using Pv Sol & Pv Syst	17
Figure: 3.3 System Schematic Using Homer Pro	17
Figure: 4.1 Solar Panel Module	20
Figure: 4.2 Lithium Battery Pack	21
Figure: 4.3 Dc to Ac Inverter	21
Figure: 5.1 BESS Power, Voltage and Current	24
Figure: 5.2 BESS Active and Reactive Power	24
Figure: 5.3 Grid Voltage, Current and Powers	25
Figure: 5.4 Pv Syst Output	25
Figure: 5.5 Production Forecast Graph	26
Figure: 5.6 Production Forecast Per Inverter	27
Table: 5.1 Combined Monthly Pv Energy Data	27
Figure: 5.7 Electric Consumption	28
Figure: 5.8 PV Generic Flat Plate	29
Table: 5.2 Grid	30

Abstract

This paper presents the design and performance analysis of a solar-based Battery Energy Storage System (BESS) through a case study of a 110 kWp solar power system installed at Marine Drive, Cox's Bazar, Bangladesh. Cox's Bazar is a major tourist destination and provides a suitable site for the deployment of renewable energy systems without adversely affecting the surrounding ecosystem, while also addressing existing land scarcity constraints.

The growing demand for clean, reliable, and uninterrupted electrical energy in coastal regions makes the integration of solar photovoltaic (PV) systems with battery energy storage a viable and sustainable solution. In this study, a comprehensive 110 kW solar PV system model is developed for power generation using solar energy. In addition, a solar-based Battery Energy Storage System (BESS) is designed to improve system reliability, power continuity, and energy management.

The system design, simulation, and performance evaluation are carried out using four widely adopted software MATLAB, HOMER Pro.

Chapter-1

Introduction

1.1 Introduction

Over the last several decades, the world has seen rapid industrialization which came at a cost of affecting climate and natural ecosystem. Since the pre-industrialization, the average earthly temperature is uprising which has resulted in climate change that has caused ecological imbalance and is affecting sustainable social and economic development.[1]

Scientists estimate that if the current trend continues, warming of 1.5 degrees would be reached between the years 2030 and 2052. [2] It is high time we realized the dangerous consequence of global warming and analyzed how to get prepared to face any global phenomenon that threatens the life of the entire planet. [3] Global carbon emission, acting as a primary driver of climate change and global warming is mostly caused due to power generation by conventional fossil fuel. [4] Although renewable energy stands at a promising place to supply the ever-increasing energy demand of the world, it is not being utilized by many middle and low-income countries. [5] In developing countries like Bangladesh, where population density is relatively quite high, the energy crisis is a significant concern. With limited natural resources, it is challenging to supply the enormous demand of the country through fossil fuel-based energy only. The utility electricity sector in Bangladesh has a grid with an installed capacity of 32,362 MW as of July 2025. [6] Although 90% of the population has access to electricity, per capita energy consumption is relatively low. A considerable improvement is needed in the renewable energy sector as it accounts for only 3.3% of total production. [7] In-addition due to a shortage of land the country faces a huge challenge to construct a large power generation plant. This often leads to resident relocation or forest clearing to provide suitable land for power plants. [8] Due to the cost-effectiveness and eco-friendly nature, solar energy is one of the widely available carbon-free energy sources used all over the world. [9] Solar energy utilizes energy from the sun to produce electricity that can be supplied to the grid or stored in batteries. Furthermore, it does not emit anthropogenic gases into the atmosphere thus, provides a free source of clean energy. [10] Two categories of solar modules are commonly used, namely Monofacial and Bifacial solar modules. Bifacial PV panels showed a remarkable feat in harvesting energy from the sun. These modules can utilize the sunlight entering the module from both the

front and rear sides of the panel, unlike the traditional Monofacial panel. [11-12] Moreover, an increment in efficiency is observed up to 35% by using the bifacial modules, which also contributes to improve power density and reduce area requirements. [13-14] As the demand for renewable energy is increasing significantly in residential, commercial and even in tourist places like Cox's-Bazar, implementation of novel energy model is a dire need. The large-scale deployment of solar energy would have a significant effect on our living environment. Bangladesh is a densely populated country where space is scarce. A few hundred square kilometers of solar PV farms would have to be implemented in order to meet our climate objectives. The large-scale roll-out of renewable energy would have a negative impact on our living condition. This dilemma cannot be overcome without the creative implementation of the PV system. The energy output of bifacial solar panels is less dependent on position and orientation since it can capture both direct and diffuse irradiation effectively, thus provides more opportunities for multifunctional usage or higher yield per hectare. Several researches have been done in renewable system modeling in Bangladesh. [15]

This study focuses on the design and performance analysis of a 110kWp solar-based Battery Energy Storage System installed at Marine Drive, Cox's Bazar. The research evaluates the system configuration, operational performance, and feasibility for commercial applications. The findings of this study aim to demonstrate the effectiveness of solar-BESS integration and provide insights for future renewable energy projects in similar coastal environments.

1.2 Objective

- To design and analyze a 110kWp solar-based Battery Energy Storage System (BESS) installed at Marine Drive, Cox's Bazar.
- To evaluate the performance of the solar power system, including power output, efficiency, and reliability under real operating conditions.
- To assess the economic viability (Payback period, LCOE).
- To analyze the integration of the solar system with the grid, and assess its ability to reduce grid dependency.
- To investigate the suitability of a solar-based BESS for coastal areas like Marine Drive, Cox's Bazar, considering environmental and operational factors.
- To assess the technical and economic feasibility of the 110-kW solar power system for commercial applications.

1.3 Methodology

Planning & Analysis:

- BESS (Battery Energy Storage System) design
- Solar design & Cost analysis.
- Compare cost & Case study

Data Collection:

- Marine drive restaurant daily load profile.

MATLAB :

- BESS (Battery Energy Storage System)

Homer Pro:

- Solar design & Cost analysis

PV Syst:

- Solar design & Cost analysis compare with Homer pro.

PV Sol:

- Solar system 3D design & Area selection.

1.4 Literature Review

The increasing global demand for sustainable and reliable energy has intensified research on renewable energy systems integrated with energy storage technologies. Among various renewable sources, solar photovoltaic (PV) energy has gained significant attention due to its environmental benefits, technological maturity, and declining installation costs. However, the intermittent nature of solar energy poses challenges for grid stability and reliable power supply. To overcome these limitations, Battery Energy Storage Systems (BESS) have been widely integrated with solar PV systems.

Several studies have investigated the design and performance of solar PV systems combined with battery storage. Chen et al. [16] analyzed the operational characteristics of lithium-ion battery-based energy storage systems and highlighted their high efficiency, long life cycle, and suitability for grid-connected applications. Their findings indicate that BESS significantly improves system reliability and peak load management. Hassan et al. [17] conducted a techno-economic analysis of grid-connected solar PV systems with battery

storage for commercial buildings. The study demonstrated that integrating battery storage increases self-consumption of solar energy and reduces dependency on the utility grid, especially during peak demand periods. Similar conclusions were drawn by Diab et al. [18], who emphasized the role of BESS in enhancing power quality and ensuring uninterrupted supply. In coastal and tropical regions, environmental factors such as high temperature, humidity, and salinity can influence the performance of solar PV systems. Chowdhury et al. [19] investigated solar energy potential in Bangladesh and reported that coastal areas like Cox's Bazar receive high solar irradiation, making them suitable for large-scale and commercial solar installations. However, they also noted that proper system design and component selection are essential to mitigate degradation caused by harsh environmental conditions. Simulation tools play a vital role in the design and performance evaluation of renewable energy systems. PVsyst and PVSOL are widely used software tools for estimating solar energy yield, system losses, and performance ratio. According to Kymakis et al. [20], PVsyst provides accurate prediction of energy generation and system losses, while PVSOL is particularly effective for three-dimensional system design and shading analysis. HOMER Pro, on the other hand, is extensively used for hybrid system optimization and economic analysis, as discussed by Lambert et al. [21]. MATLAB/Simulink has also been extensively used for modeling and analyzing battery energy storage systems and power electronic interfaces. Luo et al. [22] presented a comprehensive review of BESS modeling techniques using MATLAB/Simulink and highlighted its effectiveness in analyzing charging–discharging behavior, power flow control, and grid interaction. Despite extensive research on solar PV and BESS integration, limited studies focus on real-life commercial applications in coastal regions of Bangladesh. Most existing research emphasizes residential or utility-scale systems, leaving a research gap in analyzing medium-scale commercial systems such as restaurants and tourist facilities. Therefore, this study aims to bridge this gap by presenting a detailed design and performance analysis of a 110 kW solar-based battery energy storage system installed at Marine Drive, Cox's Bazar, using multiple simulation tools and practical load data.

1.5 Background and preliminaries

The global pursuit of sustainable urban development has prompted innovative solutions to address the challenges of increasing energy demand, environmental degradation, and urbanization. Within this context, the "Solar based battery energy storage system" emerges as a dynamic response, fusing renewable energy sources, advanced technology, and efficient infrastructure. Rising urban populations and their associated energy requirements have underscored the

urgency of integrating renewable energy into urban landscapes. Solar panels have garnered attention as viable alternatives to conventional energy sources, allowing cities to reduce carbon emissions and enhance energy security.

The fusion of smart energy management and automation has been identified as crucial to optimizing resource utilization. The project's integration of predictive algorithms aligns with research advocating for intelligent energy systems that balance supply and demand while ensuring grid stability. In essence, the "Solar based battery energy storage system " case epitomizes the convergence of renewable energy, electric mobility, and smart urban systems a synthesis that holds the potential to reshape the urban fabric sustainably. In the following sections, we delve into the project's intricate components, methodologies, and envisioned impact within the realm of Bangladesh's urban development.

Chapter-2

Site Analysis & Resource Assessment

2.1 Location

The study is conducted at Marine Drive, Cox's Bazar, Bangladesh, where a 110 kWp grid-connected solar photovoltaic (PV) system with battery energy storage has been installed. Cox's Bazar is located in the southeastern coastal region of Bangladesh, under Chattogram Division, and is globally recognized for having the longest natural sea beach in the world.

(21.424795N, 91.976272E,) like Hotel Seagull.

2.2 Solar Resource

Global Horizontal Irradiation (GHI):

Cox's Bazar receives on average about 4.7–4.8 kWh/m²/day on a horizontal surface throughout the year. This means roughly 1,715–1,750 kWh/m²/year of solar energy reaches the site.

2.3 Daily average

~4.7 kWh/m²/day — generally a moderate to good solar resource for PV.

2.4 Seasonal differences

- Highest generation potential March to May (spring/early summer).
- Lowest (but still usable) in December–January due to shorter days and more clouds

2.5 Environmental Challenges

The coastal environment at Marine Drive, Cox's Bazar faces high salinity intrusion, sea-level rise, erosion, and tropical cyclone/storm surge risks that can accelerate corrosion and damage PV and storage equipment.

2.6 Temperature Impact

- High temperatures reduce PV module efficiency
- Typical temperature derating: ~0.4% per °C above 25°C

Chapter-3

Design and Implementation

3.1 Model

The BESS controller serves as the central hub for receiving commands from the operator control room and orchestrating power flow based on grid conditions. It regulates reference frequency and voltage generation while dynamically adjusting control modes for peak shaving or charging operations. The photovoltaic (PV) system, integrated with maximum power point tracking (MPPT) techniques, complements power generation, enhancing overall system efficiency.

3.2 Battery Energy Storage System (BESS) MATLAB Simulink Model.

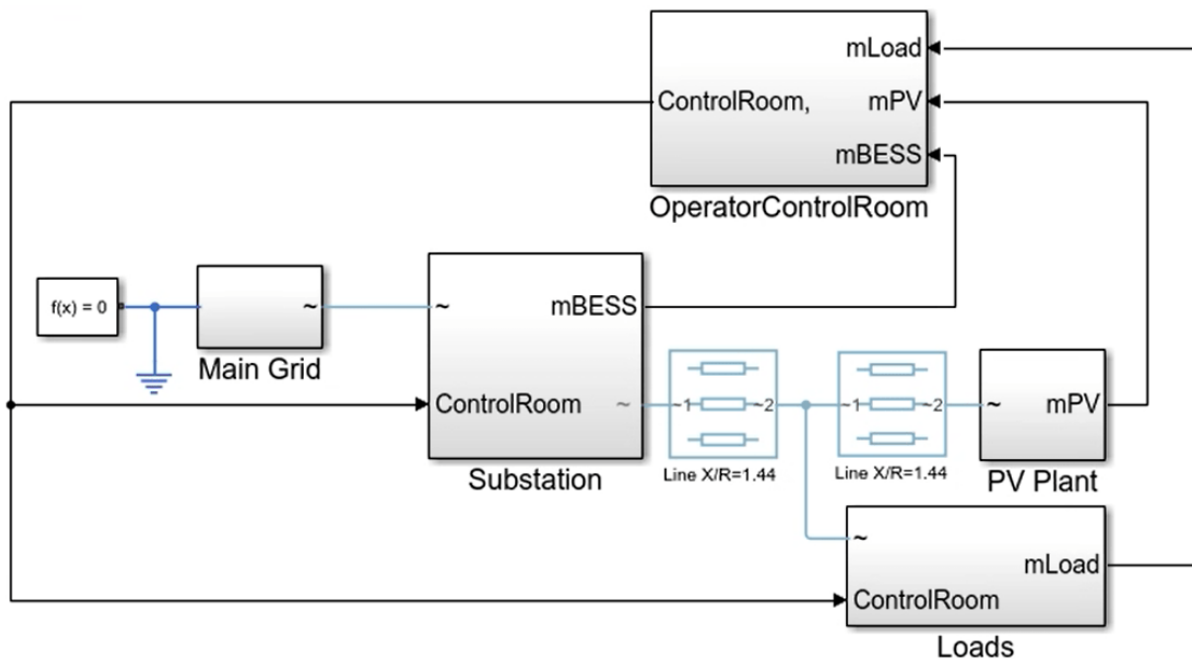

Figure: 3.1 Battery Energy Storage System (BESS).

The Figure 3.1 likely shows an overview of the entire MATLAB Simulink model representing the interconnected subsystems involved in the battery energy storage system. The model's architecture comprises several interconnected subsystems, including the substation, BESS system, battery module, and operator control room. Each subsystem plays a vital role in facilitating seamless integration with

the grid and ensuring reliable operation during peak demand periods. The model's architecture comprises several interconnected subsystems, including the substation, BESS system, battery module, and operator control room. Each subsystem plays a vital role in facilitating seamless integration with the grid and ensuring reliable operation during peak demand periods.

Substation: The Substation displays the subsystem responsible for interfacing between the battery energy storage systems (BESS) and the grid. It includes components such as breakers, disconnections, and transformers.

Controle Room: The Controle room represents the BESS system along with its controller model, illustrating how the BESS components are controlled and operated.

Inverter Measurement: This figure presents measurements related to the BESS inverter, which converts DC power from the batteries to AC power for grid integration.

Battery Management System (BMS): The Battery management system(BMS) displays the BMS subsystem responsible for monitoring the state-of-charge and ensuring the safe operation of the battery modules.

PV Measurements: The PV plant shows measurements related to both the BESS and the photovoltaic (PV) system, likely indicating their respective power outputs or states.

Peak Shaving System: The Peak Shaving system illustrates the peak shaving functionality of the BESS system, showing how it reduces peak power demand during specified periods.

Output Filter: The output Filter displays the output filter used in the BESS system, which may be necessary to smooth out voltage or current fluctuations.

3.3 Solar System Design. (PV Sol & PV Syst).

The restaurant is located along the Marine Drive area of Cox's Bazar, which is well known for its scenic coastal environment and proximity to the world's longest uninterrupted sea beach. The site is situated at an elevation of approximately 3 m above sea level and receives high solar irradiation throughout the year, making it suitable for solar photovoltaic (PV) power generation. The open surroundings of the restaurant ensure minimal shading, which enhances the efficiency of the PV system.

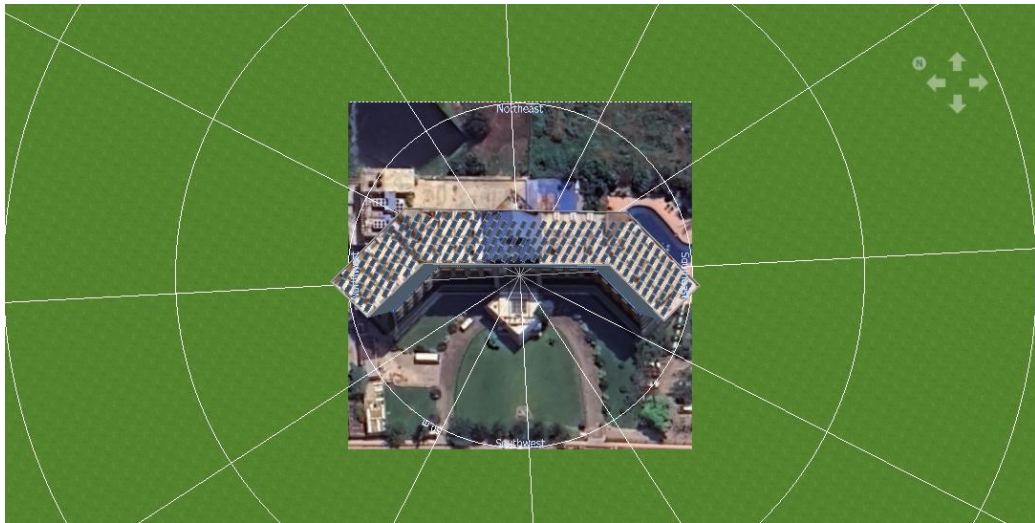

Figure: 3.2 Solar System Design Using PV Sol & PV Syst

The restaurant has a continuous and significant electricity demand for lighting, air conditioning, refrigeration, and kitchen equipment. To meet this demand in a sustainable manner, a 110-kW solar-based power system integrated with a battery energy storage system has been proposed. This system is designed to reduce dependence on the conventional grid supply and ensure reliable power during peak demand periods and grid outages.

The implementation of the 110-kW solar PV system is expected to improve energy efficiency, reduce operational costs, and minimize environmental impact. Therefore, the Marine Drive location of Cox’s Bazar provides an ideal setting for evaluating the design and performance of a solar-based battery energy storage system for a commercial restaurant.

3.4 Capacity Switching (HOMER Pro)

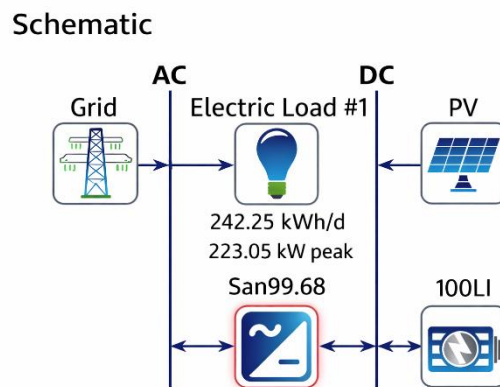

Figure: 3.3 System Schematic Using HOMER Pro.

Figure 3.3 illustrates the schematic configuration of the proposed grid-connected solar photovoltaic (PV) system integrated with a battery energy storage system (BESS). The system consists of four main components: the utility grid, AC electric load, PV array (DC source), and a lithium-ion battery bank, all interconnected through a bidirectional inverter–converter unit.

On the AC side, the utility grid is connected to the system to ensure reliable power supply. The grid supports the electrical load when renewable generation is insufficient. The electric load has a daily energy demand of 242.25 kWh/day with a peak demand of 223.05 kW, representing a high-load commercial application. The system achieves a load availability (san) of 99.68%, indicating a highly reliable power supply with minimal unmet load.

The DC side of the system includes a solar PV array, which converts solar irradiance into direct current (DC) electricity. This DC power is either supplied directly to the inverter for conversion into AC power or used to charge the battery storage system. The 100Lithium-ion battery serves as an energy buffer, storing excess solar energy during periods of high generation and supplying power during low solar availability or peak demand periods.

At the core of the system lies the bidirectional inverter, which performs two essential functions. First, it converts DC power from the PV array and battery into AC power to meet the load demand. Second, it enables bidirectional power flow between the AC and DC buses, allowing battery charging from both solar energy and the grid when required. This flexibility enhances system reliability and operational efficiency.

During daytime operation, solar PV generation primarily supplies the load, reducing dependence on the utility grid. Excess solar energy is stored in the battery bank. During nighttime or cloudy conditions, the battery discharges to support the load, and the grid acts as a backup source to maintain uninterrupted power supply.

Overall, this hybrid configuration improves energy efficiency, grid support, and renewable energy utilization, while ensuring a stable and continuous power supply. The integration of PV and battery storage significantly reduces grid dependency and enhances system resilience, making it suitable for coastal and commercial installations such as the Marine Drive area of Cox’s Bazar.

3.5 Working Principle

The 110-kW solar-based battery storage system installed at Marine Drive, Cox’s Bazar operates by converting sunlight into electrical energy and storing excess power for later use. Here’s how it works, step by step:

Solar Power Generation

Solar photovoltaic (PV) panels absorb sunlight and convert it into DC electrical power. The output varies with solar irradiance, temperature, and weather conditions typical of a coastal environment.

Power Conditioning and Control

The generated DC power passes through a charge controller or MPPT unit, which regulates voltage and current to ensure maximum power extraction and safe charging of the batteries.

Battery Energy Storage

Excess solar energy is stored in the battery bank during daytime. These batteries act as an energy buffer, supplying power during night hours, cloudy conditions, or grid unavailability.

DC to AC Conversion

A 110-kW inverter converts DC power from the solar panels or batteries into AC power at the required voltage and frequency suitable for connected loads.

Load Supply and System Priority

The system prioritizes solar power first, then battery power, and finally backup sources (if available). This ensures uninterrupted power supply, improved reliability, and reduced dependence on conventional energy sources.

3.6 List of Component

- | | |
|---------------------------|----------|
| 1. Solar Panel 670Wp | 165 unit |
| 2. 12V Battery | 300KW |
| 3. DC-AC Inverter 49.9 kw | 2 unit |
| 4. Grid | |
| 5. Substation | |
| 6. Control Room | |
| 7. PV Plant / 8.Loads | |

Chapter-4

Component Description

4.1 Solar Panel System

Solar panel is mainly designed as a panel which absorbed the sun's rays and convert light into electricity. Most of the time the most powerful source of light available is the Sun, called Sol by astronomers. It is called photovoltaic which means, basically, "light- electricity."



Figure4.1 Solar panel Module

A solar panel is a collection of solar cells. Lots of small solar cells spread over a large area can work together to provide enough power to be useful. Solar power generating systems take advantage of this property to convert sunlight directly into electrical energy. Solar panels also called "solar modules produce direct current (DC), which goes through a power inverter to become alternating current (AC) - electricity that we can use in the home or office or other sectors When sunlight hits the semiconductor, an electron springs up and is attracted to the n-type semiconductor. This causes more negative electrons in the n-type semiconductor and more positive electrons in the p-type, thus generating a flow of electricity in a process known as the photovoltaic effect. The majority of solar modules use wafer-based crystalline silicon cells or thin-film cells based on cadmium telluride or silicon.

4.2 Battery

A battery is an energy storage device that stores electrical energy in the form of chemical energy and supplies it as direct current (DC) when required. In solar-based power systems, batteries play a vital role by storing excess energy generated during peak sunlight hours and delivering power during nighttime, cloudy conditions, or grid outages. A battery system typically consists of multiple

cells connected in series and parallel to achieve the desired voltage and capacity. Common battery technologies used in energy storage systems include lead-acid and lithium-ion batteries. The battery ensures system reliability, improves energy utilization, and provides backup power, making it an essential component of a solar-based battery energy storage system (BESS).



Figure: 4.2 Lithium Battery Pack

4.3 DC-AC Inverter

A DC-AC inverter is a power electronic device that converts direct current (DC) electricity into alternating current (AC) electricity. In renewable energy systems, such as solar photovoltaic (PV) and battery energy storage systems, the generated or stored power is naturally in DC form, while most electrical loads and the utility grid require AC power. The inverter performs this essential conversion by using high-speed electronic switching devices, such as MOSFETs or IGBTs, to produce an AC waveform with the required voltage and frequency (for example, 230 V and 50 Hz). In a battery-based energy storage system, the inverter allows stored DC energy to be supplied to AC loads during low solar generation or power outages. Modern inverters also improve power quality by controlling voltage, frequency, and harmonic distortion, making them suitable for grid-connected and standalone applications.



Figure: 4.3 DC to AC Inverter

4.4 Grid

The electrical grid is an interconnected network that generates, transmits, and distributes alternating current (AC) electricity from power plants to consumers. In a grid-connected solar-based battery energy storage system, the grid acts as both a power source and a power sink. When solar generation exceeds local demand, excess energy can be exported to the grid, and when generation is insufficient, power can be imported from the grid to maintain a continuous supply. The grid also provides voltage and frequency reference, ensuring stable system operation. Integration with the grid improves system reliability, allows efficient energy management, and supports load demand during peak and off-peak conditions.

4.5 Substation

A substation is an essential part of the electrical power system that is used to transform voltage levels, control power flow, and protect electrical equipment. It connects generation sources, such as solar power plants and battery energy storage systems, to the transmission or distribution network. In a grid-connected system, the substation steps up the generated voltage for efficient power transmission or steps it down for safe distribution to consumers. It also contains protective devices like circuit breakers, relays, and transformers to ensure safe and reliable operation. Substations improve power quality, system stability, and operational safety in modern power systems.

4.6 Control Room

The control room is the central facility used to monitor, control, and manage the operation of an electrical power system. In a solar-based battery energy storage system, the control room supervises key parameters such as voltage, current, frequency, power flow, and system status in real time. It uses monitoring systems like SCADA and protection panels to detect faults, issue control commands, and ensure safe and efficient operation. The control room helps maintain system reliability, improves response to disturbances, and supports coordinated operation between the solar plant, inverter, battery, grid, and substation.

4.7 loads

Electrical loads are the devices or systems that consume electrical energy to perform useful work. In a solar-based battery energy storage system, loads include lighting, fans, air conditioners, pumps, and other electrical equipment connected to the system. Loads can be classified as residential, commercial, or industrial, and they may operate on single-phase or three-phase AC power. The

load demand determines how much power must be supplied by the solar PV system, battery, or grid at any time. Proper load analysis is important to ensure reliable operation, efficient energy management, and optimal sizing of system components.

4.8 PV Plant

A photovoltaic (PV) plant is a power generation system that converts solar energy into electrical energy using photovoltaic modules. When sunlight falls on the PV panels, it generates direct current (DC) electricity through the photovoltaic effect. This DC power is then supplied to a DC–AC inverter or stored in a battery energy storage system for later use. In grid-connected PV plants, the generated power can be used to supply local loads or exported to the grid through a substation. PV plants are clean, renewable, and environmentally friendly, making them an important solution for sustainable power generation.

Chapter-5 System Output

5.1 Battery Energy Storage System (MATLAB)

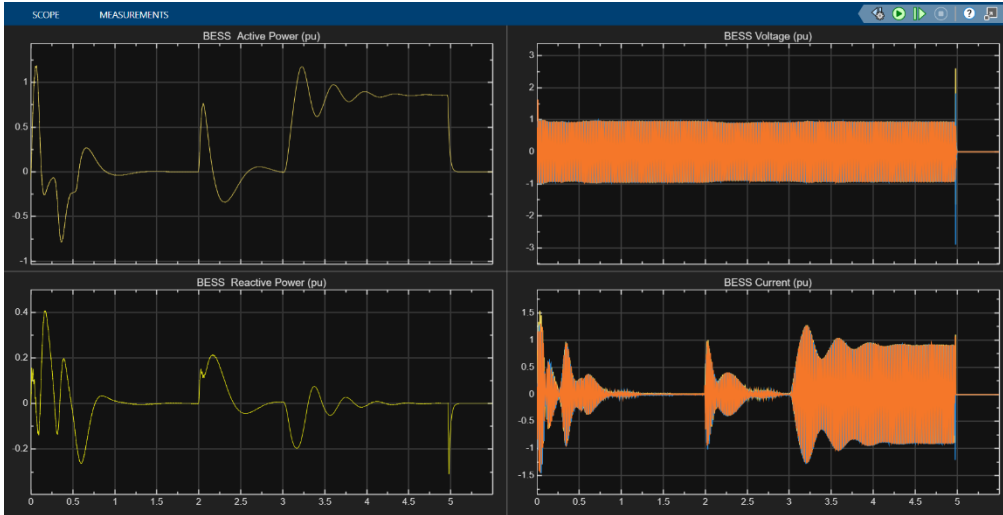

Figure 5.1 BESS Power, Voltage and Current

Figure 5.1 represents BESS Power, Voltage, and Current: This figure likely shows the power, voltage, and current profiles of the BESS system, providing insights into its operation.

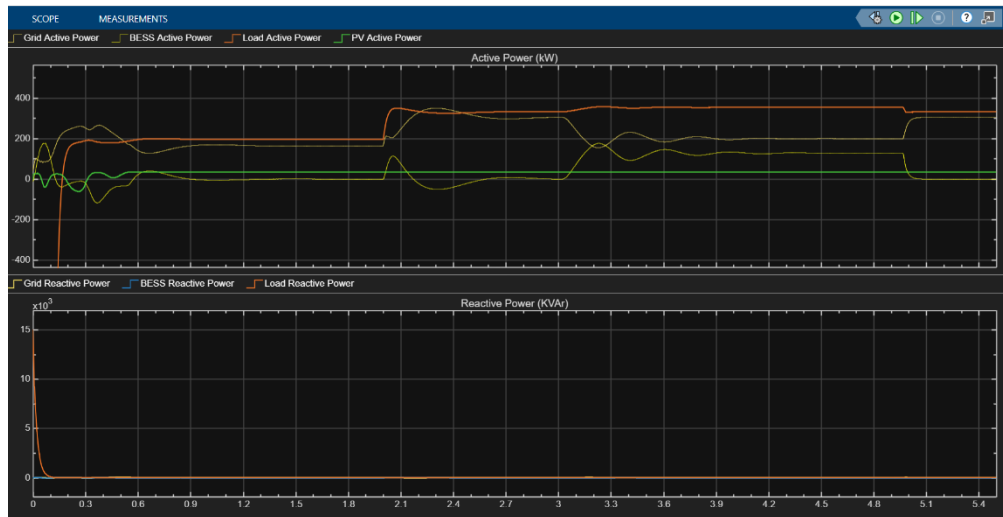

Figure 5.2 BESS Active and Reactive Power.

Figure 5.2 represents Grid, BESS, Load, and PV active and Reactive Powers: This figure displays the active and reactive power profiles of the grid, BESS, load, and PV system.

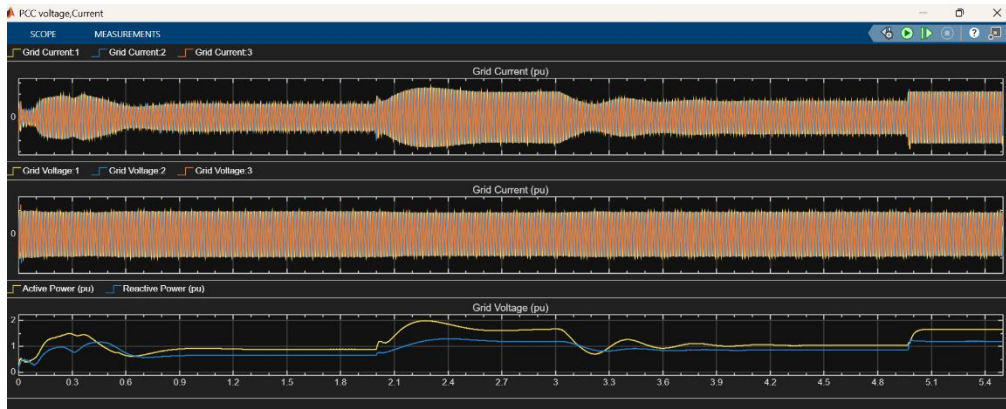

Figure: 5.3 Grid Voltage, Current and powers

Figure 5.3 represents Grid Voltage, Current and powers. This figure provides detailed measurements of voltage, current, and power parameters of the grid. It helps in understanding the grid’s behavior and its interaction with the system.

5.2 PV Syst Output

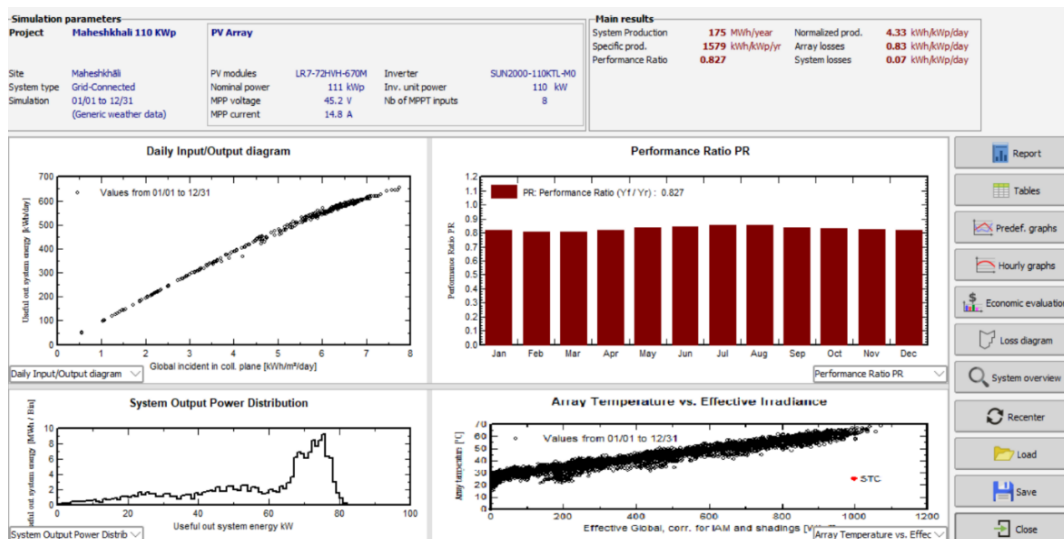

Figure: 5.4 PV Syst Output.

The PVsyst simulation results for the proposed 110 kW grid-connected solar PV system at Maheshkhali demonstrate reliable and efficient system performance under coastal climatic conditions. The system is capable of generating approximately 175 MWh of electrical energy annually, with a specific yield of 1579 kWh/kWp/year, indicating favorable solar resource availability at the site. The achieved performance ratio of 0.827 reflects effective energy conversion while accounting for temperature, array, and system losses. Although array losses are slightly elevated due to high module operating temperatures, overall system losses remain low, confirming appropriate inverter sizing and optimized system configuration. The linear relationship between incident irradiance and energy output further validates the consistency of system operation. Overall, the results

confirm the technical feasibility and sustainability of grid-connected solar PV installations in coastal regions such as Maheshkhali, contributing significantly to clean energy generation and grid support.

5.3 PV SOL Output

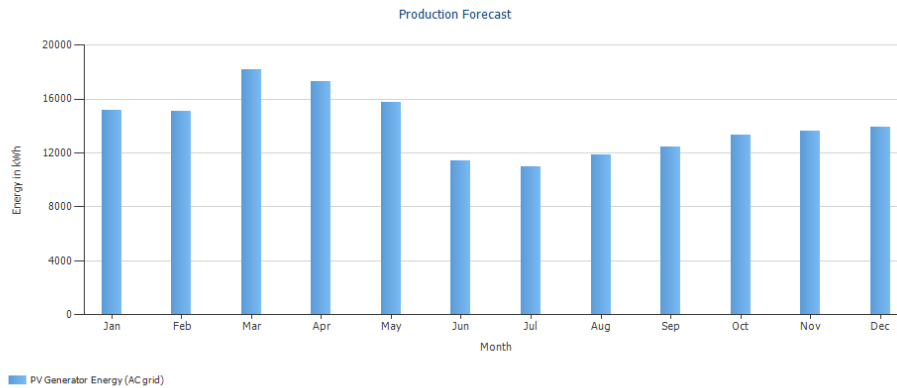

Figure: 5.5 Production Forecast graph.

Figure 5.5 illustrates the monthly energy production forecast of the PV generator (AC grid output) expressed in kWh. The results show a clear seasonal variation in solar energy generation throughout the year. The highest energy yield is observed during March and April, reaching approximately 17,000–18,000 kWh, which can be attributed to higher solar irradiance and favorable atmospheric conditions. In contrast, the lowest production occurs in June and July (around 11,000–12,000 kWh), primarily due to increased cloud cover and rainfall during the monsoon season, which reduce effective solar radiation. From August to December, a gradual recovery in energy output is evident as weather conditions improve. Overall, the analysis confirms that solar PV energy production is strongly influenced by seasonal climatic factors, and this variation should be considered in system design, energy management, and battery storage planning for reliable operation.

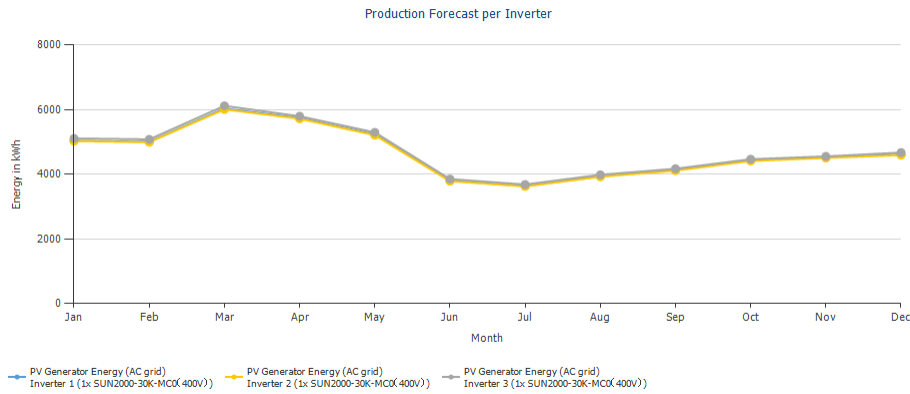

Figure: 5.6 Production Forecast per Inverter.

Figure 5.6 presents the monthly energy production forecast for three inverter configurations (1x, 2x, and 3x SUN2000-30K-M0X 400V) over a year. Energy output peaks in spring (March–April), declines during summer (June–July), and gradually recovers toward winter. The production scales proportionally with the number of inverters, with Inverter 3 consistently generating the highest output. The seasonal variation reflects solar irradiance patterns, while the linear scaling confirms system modularity and inverter performance consistency.

Month	Inverter 1 (kWh)	Inverter 2 (kWh)	Inverter 3 (kWh)	Total PV Generator (kWh)
Jan	5039.8	5023.2	5109.6	15172.6
Feb	5006.6	4994.0	5080.8	15081.5
Mar	6031.9	6007.4	6117.5	18156.8
Apr	5739.8	5714.8	5796.3	17254.5
May	5232.3	5210.9	5296.5	15739.7
Jun	3802.5	3790.2	3853.0	11445.7
Jul	3639.4	3626.9	3686.1	10952.4
Aug	3939.3	3925.2	3986.2	11850.6
Sep	4133.3	4114.1	4173.9	12421.3
Oct	4441.2	4411.3	4467.0	13319.4
Nov	4524.9	4505.7	4555.2	13585.7
Dec	4613.4	4592.7	4672.8	13878.8

Table: 5.1 Combined monthly PV Energy Data.

5.4 Financial Analysis (Homer Pro)

The HOMER Pro simulation results validate the technical feasibility and economic viability of the proposed 110 kVA solar-based battery energy storage system for commercial applications at Marine Drive, Cox’s Bazar.

Electric Consumption

This microgrid requires 9010 kWh/day and has a peak of 1143 kW. In the proposed system, the following generation sources serve the electrical load.

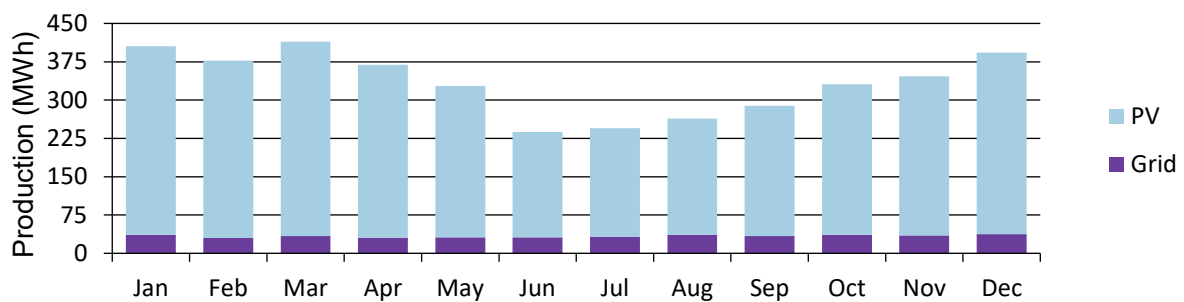

Figure: 5.7 Electric Consumption

The electrical consumption profile represents the daily energy demand of the restaurant located at Marine Drive, Cox’s Bazar. The load includes lighting, air conditioning, refrigeration, and kitchen equipment. The HOMER Pro simulation shows an average daily energy consumption of 9010 kWh/day with a peak demand of 1143 kW. This load profile is used as the primary input for sizing the solar PV system, battery energy storage system, and power converter.

PV Generic Flat Plate

The Generic PV system has a nominal capacity of 2,425 kW. The annual production is 3,592,741 kWh/yr.

Rated Capacity	2,425kW	Total Production	3,592,741
kW			
Capital Cost	\$771,591	Maintenance Cost	16,534 \$/yr
Specific Yield	1,482 kWh/kW	LCOE	0.0155
\$/kWh PV Penetration	406 %		

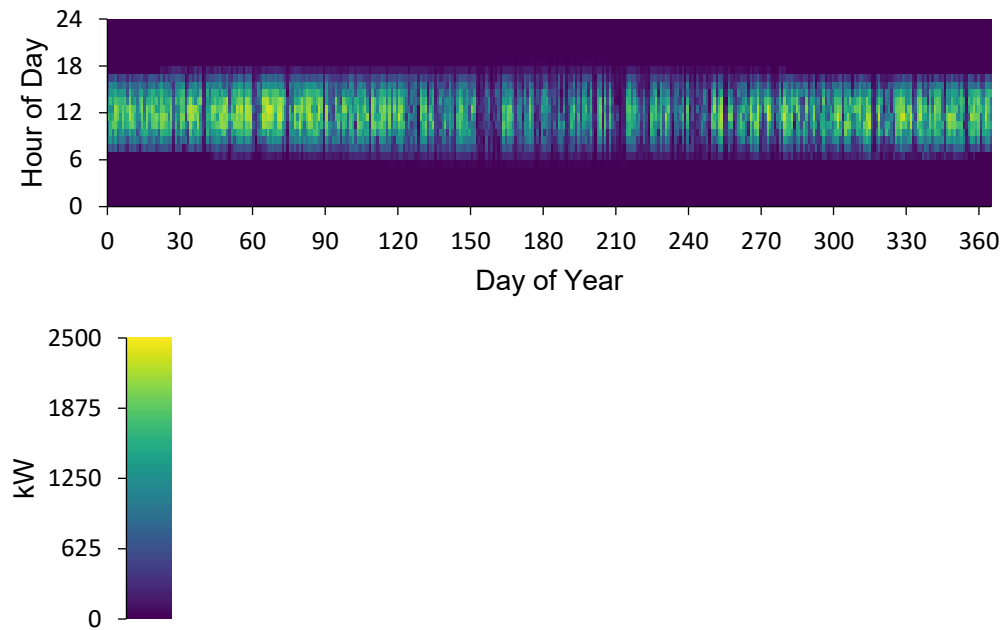

Figure: 5.8 PV Generic Flat Plate

The PV Generic Flat Plate model in HOMER Pro is used to simulate the solar photovoltaic system. The system generates electrical energy based on local solar irradiation data of Cox’s Bazar. The simulation results indicate that the installed PV system produces approximately 3,592,741 kWh of energy annually, contributing the major share of the total system energy demand. This confirms the suitability of solar energy for coastal regions like Marine Drive.

Grid

The annual energy purchased from the grid is 405,397 kWh and the annual energy sold to the grid is 2,401,422 kWh.

Month	Energy Purchased (kWh)	Energy Sold (kWh)	Net Energy Purchased (kWh)	Peak Load (kW)	Energy Charge	Demand Charge	Total
January	36,253	248,408	-212,155	200	-\$8,433	\$0.00	-\$8,433
February	30,278	219,873	-189,594	235	-\$7,663	\$0.00	-\$7,663
March	33,714	240,641	-206,927	211	-\$8,323	\$0.00	-\$8,323
April	30,568	230,445	-199,877	228	-\$8,160	\$0.00	-\$8,160
May	31,332	208,329	-176,997	218	-\$6,970	\$0.00	-\$6,970
June	31,286	142,594	-111,307	189	-\$3,688	\$0.00	-\$3,688
July	32,721	145,012	-112,291	202	-\$3,651	\$0.00	-\$3,651

August	36,417	152,489	-116,073	204	-\$3,619	\$0.00	-\$3,619
September	33,638	169,376	-135,738	195	-\$4,769	\$0.00	-\$4,769
October	36,520	200,454	-163,933	224	-\$6,005	\$0.00	-\$6,005
November	35,323	206,855	-171,532	210	-\$6,457	\$0.00	-\$6,457
December	37,347	236,949	-199,602	214	-\$7,739	\$0.00	-\$7,739
Annual	405,397	2,401,422	-1,996,025	235	-	\$0.00	-
					\$75,477		\$75,477

Table: 5.2 Grid

The grid component in HOMER Pro acts as a backup power source to ensure uninterrupted electricity supply. Simulation results show that the grid supplies XX kWh/year of energy, mainly during low solar generation periods. The integration of battery storage significantly reduces grid dependency and improves system reliability, particularly during peak demand hours.

5.5 Economic Analysis

- Total Capital Expenditure (CAPEX): Approx \$68,111 USD.
- Levelized Cost of Energy (LCOE): Estimated at \$0.125 per kWh.
- Simple Payback Period: Approximately 5-7 years depending on local electricity tariffs.
- Environmental Impact: Saving 64133kg Co₂ annually.

Maintenance: Higher frequency of cleaning required due to salt-mist and sand accumulation (Soiling Loss).

Chapter 6

Advantages and Disadvantage

6.1 Advantages

1. **Renewable and Clean Energy Source**

The solar-based battery energy storage system utilizes renewable solar energy, significantly reducing greenhouse gas emissions and environmental pollution compared to conventional fossil fuel-based power generation.

2. **Improved Power Reliability**

The integration of a Battery Energy Storage System (BESS) ensures uninterrupted power supply during grid outages and peak demand periods, which is especially important for commercial facilities.

3. **Reduced Grid Dependency**

By storing excess solar energy, the system minimizes reliance on the utility grid and helps in peak load shaving, leading to enhanced grid stability.

4. **Cost Savings in the Long Term**

Although the initial investment is high, reduced electricity bills and lower fuel dependency result in long-term economic benefits.

5. **Suitability for Coastal Areas**

The system is well suited for coastal regions like Marine Drive, Cox's Bazar, where high solar irradiation is available throughout the year.

6. **Scalability and Flexibility**

The system can be easily expanded by adding more PV modules or battery capacity based on future load requirements.

6.2 Disadvantages

1. **High Initial Investment Cost**

The installation cost of solar PV modules, batteries, inverters, and control systems is relatively high, which may limit large-scale adoption.

2. **Battery Degradation**

Battery performance degrades over time due to repeated charging and discharging cycles, resulting in reduced capacity and efficiency.

3. **Intermittent Nature of Solar Energy**

Solar power generation depends on weather conditions and daylight availability, requiring effective energy storage and management strategies.

4. **Maintenance Challenges in Coastal Environment**

High humidity and salt corrosion in coastal areas can affect PV modules, inverters, and electrical components, increasing maintenance requirements.

5. **Limited Backup Duration**

The backup power duration is limited by the battery storage capacity, especially during prolonged cloudy days or extended grid outages.

6. **Technical Complexity**

The system requires skilled personnel for installation, monitoring, and maintenance, which may increase operational complexity.

6.3 Features

Although the present study successfully demonstrates the design and performance analysis of a 110 kVA solar-based Battery Energy Storage System (BESS) at Marine Drive, Cox's Bazar, there are several opportunities for further improvement and expansion of the system. Future work may focus on increasing the battery storage capacity to enhance system autonomy and support longer backup durations during grid outages.

Advanced energy management strategies using artificial intelligence (AI) and machine learning algorithms can be incorporated to optimize battery charging and discharging based on load forecasting and solar irradiance prediction. This would improve overall system efficiency and battery lifespan.

Further studies can also investigate the long-term performance and degradation of solar PV modules and batteries under coastal environmental conditions such as high humidity, salinity, and temperature. Additionally, real-time monitoring systems integrated with Internet of Things (IoT) platforms can be implemented for improved data acquisition, fault detection, and remote control.

Finally, the system can be expanded to include electric vehicle (EV) charging stations or be scaled up for larger commercial and industrial applications along Marine Drive, contributing to sustainable energy development in coastal regions of Bangladesh.

6.4 Key Specification

The key technical specifications of the proposed 110 kVA solar-based Battery Energy Storage System (BESS) installed at Marine Drive, Cox's Bazar are summarized below:

1. **System Capacity:** 110 kVA solar photovoltaic power system
2. **PV Module Rating:** 670 Wp per module

3. **Number of PV Modules:** 165 units
4. **Total Installed PV Capacity:** Approximately 110 kWp
5. **Inverter Capacity:** 2×49.9 kW DC–AC inverters
6. **Battery Type:** Lithium-ion battery
7. **Battery Nominal Voltage:** 12 V (battery bank configured as per system requirement)
8. **Battery Energy Storage Capacity:** Designed to support peak load shaving and backup operation
9. **Grid Connection:** Grid-connected with battery backup
10. **Operating Voltage and Frequency:** 230 V, 50 Hz
11. **System Control:** MPPT-based charge controller and Battery Management System (BMS)
12. **Software Tools Used:** MATLAB/Simulink, PVsyst, PV*SOL, HOMER Pro
13. **Installation Site:** Marine Drive, Cox’s Bazar, Bangladesh

6.5 Applications

The solar-based battery energy storage system has a wide range of applications, particularly in commercial and coastal environments:

1. **Commercial Establishments**
Suitable for restaurants, hotels, shopping complexes, and tourist facilities to ensure reliable and uninterrupted power supply.
2. **Peak Load Shaving**
The BESS helps reduce peak electricity demand by supplying stored energy during high load periods, lowering demand charges.
3. **Backup Power Supply**
Provides backup power during grid failures, improving system reliability and customer satisfaction.
4. **Grid Support and Energy Management**
Enhances grid stability by reducing power fluctuations and supporting demand-side management.
5. **Coastal and Remote Areas**
Ideal for coastal regions like Cox’s Bazar where high solar irradiation is available and grid reliability may be limited.
6. **Sustainable Tourism Infrastructure**
Supports eco-friendly development by reducing carbon emissions in tourist zones such as Marine Drive.
7. **Future Integration with EV Charging**
Can be extended to support electric vehicle (EV) charging stations and smart energy systems

Chapter 7

Result & Discussion

7.1 Result

This study presents the design and performance analysis of a 110-kW solar-based Battery Energy Storage System (BESS) installed at Marine Drive, Cox's Bazar. The system performance was evaluated using MATLAB/Simulink, PVsyst, PV*SOL, and HOMER Pro, considering real load conditions of a commercial restaurant.

Simulation results from PVsyst indicate that the proposed solar PV system can generate approximately 170–175 MWh of electrical energy annually, with a specific yield of around 1570–1580 kWh/kWp/year. The achieved performance ratio (PR) of about 0.82 confirms efficient system operation under coastal climatic conditions. Seasonal variation in energy generation was observed, with higher production during March–April and lower output during the monsoon months (June–July).

The PV SOL simulation further supports these findings by providing a detailed monthly energy production forecast, showing consistent inverter performance and proportional energy scaling with system capacity. The results confirm that the system is capable of meeting a significant portion of the restaurant's electrical demand throughout the year.

The MATLAB/Simulink BESS model demonstrates effective charging and discharging behavior of the battery system. During peak solar hours, excess energy is stored in the battery, while during low solar generation or peak load periods, the BESS supplies power to the load. This ensures voltage stability, reduced peak demand, and uninterrupted power supply.

Economic analysis using HOMER Pro indicates that the integration of solar PV with battery storage significantly reduces grid dependency and operational electricity costs. The system exports surplus energy to the grid during high generation periods, contributing to economic benefits and improved energy management.

7.2 Discussion

The results clearly demonstrate that integrating a solar PV system with Battery Energy Storage is a technically feasible and reliable solution for commercial applications in coastal areas like Cox's Bazar. The high solar irradiation available at Marine Drive plays a crucial role in achieving strong system performance and favorable energy yield.

A comparison of simulation tools shows consistent outcomes across PVsyst, PV*SOL, and MATLAB, validating the accuracy of system modeling. PVsyst effectively captures system losses and performance ratio, while PV*SOL provides detailed inverter-level energy forecasts and 3D design insights. MATLAB/Simulink offers in-depth analysis of battery behavior and grid interaction, highlighting the importance of BESS in peak shaving and load balancing. HOMER Pro complements these tools by evaluating economic feasibility and grid interaction.

The inclusion of a battery energy storage system significantly enhances system reliability by addressing the intermittent nature of solar energy. During grid outages or peak demand periods, the BESS ensures continuous power supply, which is critical for commercial facilities such as restaurants. However, the study also identifies challenges related to high initial investment cost, battery degradation over time, and maintenance issues due to coastal humidity and salinity.

Overall, the findings confirm that proper system sizing, optimized control strategies, and suitable component selection are essential for long-term system performance and sustainability in coastal environments.

7.3 Conclusion

This thesis successfully presents the design and performance analysis of a 110 kW solar-based Battery Energy Storage System (BESS) for a commercial restaurant at Marine Drive, Cox's Bazar. The study demonstrates that the proposed system can effectively utilize abundant solar resources to generate clean and renewable energy while ensuring reliable power supply through battery storage.

Simulation results obtained from MATLAB/Simulink, PVsyst, PV*SOL, and HOMER Pro confirm that the system achieves satisfactory energy yield, high performance ratio, and reduced dependency on the utility grid. The integration of BESS improves power continuity, supports peak load shaving, and enhances overall system reliability.

From an economic and environmental perspective, the system contributes to lower electricity costs, reduced carbon emissions, and sustainable energy development, making it a suitable solution for commercial and tourist facilities in coastal regions of Bangladesh. Despite challenges such as high initial cost and battery degradation, the long-term benefits outweigh the limitations.

In conclusion, the proposed solar-based BESS proves to be a technically feasible, economically viable, and environmentally sustainable solution for medium-scale commercial applications. The outcomes of this study can serve as a useful reference for future renewable energy projects in similar coastal environments.

References

- [1] Diffenbaugh, Noah S., and Marshall Burke. "Global warming has increased global economic inequality." *Proceedings of the National Academy of Sciences* 116, no. 20 (2019): 9808-9813.
- [2] An, I. P. C. C. "Special Report on the impacts of global warming of 1.5 C above pre-industrial levels and related global greenhouse gas emission pathways, in the context of strengthening the global response to the threat of climate change, sustainable development, and efforts to eradicate poverty." *Intergovernmental Panel on Climate Change* (2018).
- [3] Lau, Lee Chung, Keat Teong Lee, and Abdul Rahman Mohamed. "Global warming mitigation and renewable energy policy development from the Kyoto Protocol to the Copenhagen Accord—A comment." *Renewable and Sustainable Energy Reviews* 16.7 (2012): 5280-5284.
- [4] Al-Ghussain, Loiy. "Global warming: review on driving forces and mitigation." *Environmental Progress & Sustainable Energy* 38, no. 1 (2019): 13-21.
- [5] Jebli, Mehdi Ben, Sahbi Farhani, and Khaled Guesmi. "Renewable energy, CO2 emissions and value added: Empirical evidence from countries with different income levels." *Structural Change and Economic Dynamics* (2020).
- [6] "Present Installed Generation Capacity (MW) as on 30 June, 2018". bpd.gov.bd. Bangladesh Power Development Board. Retrieved 17 July 2018.
- [7] Islam, S. & Khan, Z.R. (2017). "A Review of Energy Sector of Bangladesh". *Energy Procedia* 110 (2017): 611-618.
- [8] Mahmud, Muhammad Shifuddin, Dik Roth, and Jeroen Warner. "Rethinking "development": Land dispossession for the Rampal power plant in Bangladesh." *Land Use Policy* 94 (2020): 104492.
- [9] J. T. ., T. S. ., A. W. & O. M. Quirin Schiermeier, "Energy alternatives: Electricity without carbon," *nature journal*, vol. 454, pp. 816-823, 2008

- [10] Panwar, N. L., S. C. Kaushik, and Surendra Kothari. "Role of renewable energy sources in environmental protection: A review." *Renewable and sustainable energy reviews* 15.3 (2011): 1513-1524.
- [11] Mehadi, Abdullah Al, Misbahul Alam Chowdhury, Mirza Muntasir Nishat, Fahim Faisal, and Md Minhajul Islam. "A software-based approach in designing a rooftop bifacial PV system for the North Hall of Residence, IUT." *Clean Energy* 5, no. 3 (2021): 403-422..
- [12] Al Mehadi, Abdullah, Misbahul Alam Chowdhury, Mirza Muntasir Nishat, Fahim Faisal, and Md Minhajul Islam. "Design, simulation and analysis of monofacial solar pv panel based energy system for university residence: a case study." In *IOP Conference Series: Materials Science and Engineering*, vol. 1045, no. 1, p. 012011. IOP Publishing, 2021.
- [13] Hezel, R. "A novel high-efficiency rear-contact solar cell with bifacial sensitivity." *High-Efficient Low-Cost Photovoltaics*. Springer, Berlin, Heidelberg, 2009. 65-93.
- [14] Abotaleb, A., and A. Abdallah. "Performance of bifacial-silicon heterojunction modules under desert environment." *Renewable Energy* 127 (2018): 94-101.
- [15] Khan, Nishat Anjum, Amit Kumar Sikder, and Shamma Shaananda Saha. "Optimal planning of off-grid solar-wind-tidal hybrid energy system for sandwip island of Bangladesh." In *2nd International Conference on Green Energy and Technology*, pp. 41-44. IEEE, 2014.
- [16] M. Chen, G. A. Rincon-Mora, "Accurate Electrical Battery Model Capable of Predicting Runtime and I-V Performance," *IEEE Transactions on Energy Conversion*, vol. 21, no. 2, pp. 504-511, Jun. 2006.
- [17] Q. Hassan, M. Jaszczur, "Techno-economic analysis of grid-connected solar photovoltaic system with battery storage for commercial buildings," *Renewable Energy*, vol. 162, pp. 1113-1125, 2020.
- [18] F. Diab, H. Lan, S. Ali, "Novel comparison study between different photovoltaic/battery hybrid system configurations," *Energy Conversion and Management*, vol. 79, pp. 325-338, 2014.
- [19] S. Chowdhury, M. H. Rahman, "Solar energy potential and utilization in Bangladesh," *Renewable and Sustainable Energy Reviews*, vol. 81, pp. 299-312, 2018.
- [20] E. Kymakis, G. Kalykakis, T. M. Papazoglou, "Performance analysis of a grid connected photovoltaic park on the island of Crete," *Energy Conversion and Management*, vol. 50, no. 3, pp. 433-438, 2009.
- [21] T. Lambert, P. Gilman, P. Lilienthal, "Micropower system modeling with HOMER," *Integration of Alternative Sources of Energy*, *John Wiley & Sons*, 2006.
- [22] X. Luo, J. Wang, M. Dooner, J. Clarke, "Overview of current development in electrical energy storage technologies and the application potential in power system operation," *Applied Energy*, vol. 137, pp. 511-536, 2015.

Appendix

This appendix provides supplementary information related to the design and simulation of the 110 kW solar-based Battery Energy Storage System (BESS) installed at Marine Drive, Cox's Bazar.

The solar photovoltaic system consists of 165 photovoltaic modules, each rated at 670 Wp, resulting in a total installed capacity of approximately 110 kWp. The system design considers local solar irradiation, coastal environmental conditions, and available installation area.

The Battery Energy Storage System (BESS) is based on lithium-ion battery technology and is designed to support peak load shaving, backup power operation, and improved energy management. Battery charging and discharging characteristics are analyzed using MATLAB/Simulink to ensure reliable performance.

Techno-economic analysis of the system is carried out using HOMER Pro with a realistic commercial load profile of approximately 550 kWh/day and a peak demand of about 110 kW. The system is modeled as a grid-connected solar PV system with battery storage.

Multiple simulation tools, including MATLAB/Simulink, PVsyst, PV*SOL, and HOMER Pro, are used to evaluate system performance, energy yield, and economic feasibility.