

# **DESIGN AND CONTRUCTION OF A SOLAR BASED BELT TYPE OIL SKIMMER**

A Thesis Submitted to the Department of Mechanical Engineering Sonargaon University (Su) in partial fulfillment of the requirements for the award of the degree of Bachelor of Science in Mechanical Engineering



## **Submitted by**

Md.Sohel Rana	ID : ME2103025176
Md.Mozammel Haque	ID : ME2202027288
Md Tohidul Islam	ID : ME2202027184
Md Lokman hossain Chowdhury	ID : ME2202027181
MD. Mahdi Hasan	ID : ME2202027238

## **Supervised by**

Md. Toriqul Islam  
Lecturer

**January 2026**

# **DESIGN AND CONTRUCTION OF A SOLAR BASED BELT TYPE OIL SKIMMER**

A Thesis

By

**Md. Sohel Rana**

Student No : ME2103025176

In Cooperation With

**Md.Mozammel Haque**

Student No : ME2202027288

**Md Tohidul Islam**

Student No : ME2202027184

**Md Lokman hossain Chowdhury**

Student No : ME2202027181

**MD. Mahdi Hasan**

Student No : ME2202027238

Supervisor : Md. Toriqul Islam

Lecturer

Submitted to the

DEPARTMENT OF MECHANICAL ENGINEERING

SONARGAON UNIVERSITY (SU)

In partial fulfillment of the requirements for the award of the degree  
of

BACHELOR OF SCIENCE IN MECHANICAL ENGINEERING

January 2026

# ACKNOWLEDGEMENT

First and foremost, we express our heartfelt gratitude to the Almighty for giving us the strength, patience, and perseverance to complete this project successfully. We would like to sincerely thank our supervisor, Md. Toriqul Islam, Lecturer, Department of Mechanical Engineering, for his invaluable guidance, support, and continuous encouragement throughout the course of this project. His expertise, constructive feedback, and motivation played a crucial role in shaping the direction and outcome of this work. We are also grateful to the entire faculty and staff of the Department of Mechanical Engineering at our university for providing us with access to laboratory facilities, tools, and technical advice during the construction and assembly phases. Special thanks to our fellow students and friends for their moral support, idea sharing, and encouragement during challenging moments of this project. Lastly, we thank our families for their patience, understanding, and unwavering support during this demanding yet rewarding journey. This project was not only a technical endeavor but a learning experience that helped us understand the true spirit of innovation, teamwork, and sustainability.

## **ABSTARCT**

The Solar Based Belt Type Oil Skimmer with IoT System is designed to efficiently remove floating oil from polluted water bodies using renewable energy and smart monitoring. It employs an oleophilic belt mechanism that selectively attracts oil, lifts it from the water surface, and scrapes it into a collection container for safe disposal or recycling. The system is powered by solar energy, making it suitable for remote and off-grid locations. An integrated IoT module monitors motor status, oil level, and power availability in real time, sending data to the cloud for remote supervision. This project offers an eco-friendly, automated, and cost-effective solution for water pollution control.

# **CERTIFICATION**

This thesis entitled as "Design and Construction a Solar powered Belt Type Oil Skimmer" submitted by the group as mentioned below has been accepted as satisfactory as a part of the requirements in order to complete the B.Sc. degree at the Department of Mechanical Engineering, Sonargaon University, Dhaka, Bangladesh. This paper embodies the original work done under my super vision.

## **Group Members**

---

**Md. Sohel Rana**

Student No : ME2103025176

---

**Md.Mozammel Haque**

Student No : ME2202027288

---

**Md Tohidul Islam**

Student No : ME2202027184

---

**Md Lokman hossain Chowdhury**

Student No : ME2202027181

---

**MD. Mahdi Hasan**

Student No : ME2202027238

Supervisor

---

**Md. Toriqul Islam**

Lecturer

Department of Mechanical Engineering  
Sonargaon University, Dhaka, Bangladesh

# TABLE OF CONTENTS

Acknowledgement		iii
Abstract		iv
Certification		v
List of Figure		viii
List of Table		ix
<b>CHAPTER-1</b>	<b>INTRODUCTION</b>	
1.1	Introduction	01
1.2	Problem Statement	01
1.3	Scope of Use	02
1.4	Objectives	02
1.5	Work Flow Diagram	02
<b>CHAPTER 2</b>	<b>LITERATURE REVIEW</b>	
2.1	Introduction	04
2.2	Releted Research / Work	04
2.3	Summary	05
<b>CHAPTER-3</b>	<b>HARDWARE AND SOFTWARE ANALYSIS</b>	
3.1	Introduction	06
3.2	Hardware and Software	06
3.3	DC Gear Motor	06
3.4	Conveyor Belt	07
3.5	Pulley	08
3.6	Bearing	09
3.7	Solar panel	10
3.8	Battery	11
3.9	Buck Converter	12
3.10	Node MCU	14
3.11	Relay Module	15
3.12	Arduino IDE	17

<b>CHAPTER-4</b>	<b>SYSTEM ARCHTECTURE</b>	
4.1	Introduction	19
4.2	Methodology	19
4.3	System Design	19
4.4	Block Diagram	20
4.5	Working Principle	21
4.6	Cost Analysis	21
<b>CHAPTER-5</b>	<b>RESULT ANALYSIS</b>	
5.1	Project outcome	23
5.2	Complete Project prototype	24
5.3	Advantage	25
5.4	Application	25
5.5	Limitation	26
<b>CHAPTER-6</b>	<b>CONCLUSION</b>	
6.1	Conclusion	27
6.2	Future Scope	27
<b>References</b>		<b>28</b>

# LIST OF FIGURES

<b>FIGURE NO</b>	<b>FIGURE NAME</b>	<b>PAGE NO</b>
1.1	Work Flow Digram	02
3.1	DC Gear Motor	07
3.2	Conveyor Belt	08
3.3	Pulley	09
3.4	Bearing	10
3.5	Solar Panel	11
3.6	3.7V Battery	11
3.7	DC-DC buck Convetrer	13
3.8	Node MCU	14
3.9	Relay	15
3.10	Pin diagram of Relay Module	15
3.11	Main Voltage Connection	16
3.12	Arduino Software Interface IDE	17
4.1	Basic Drawing of this System	20
4.2	Block Diagram of Oil Skimer	20
5.1	Project Progress Image	24
5.2	Final Project Image	25

# LIST OF TABLE

<b>TABLE NO</b>	<b>TABLE NAME</b>	<b>PAGE NO</b>
01	Pulley Specification	09
02	Specification of Bearing	10
03	Battery Specification	12
04	Buck Converter Specification	13
05	Pin Wiring of Relay Module	16
06	Components name and Price	33
07	Components name and Market Price	22

# CHAPTER 1

## INTRODUCTION

### 1.1 Introduction

In an era of increasing environmental concern, oil pollution arising either from marine accidents or from routine ship operations (tanker loading and unloading, etc.) is a major threat for the marine environment. Although sea traffic produces minimal disruption to the environment when compared to other modes of transport, maritime transport of oil and other hazardous goods has a higher risk since the consequences of pollution are often catastrophic. The average quantity of ship-generated oil that ends up in the sea exceeds 350,000 tonnes per year. When an oil spill occurs, either in open or confined seas, the ecological damage on the local ecosystem could be huge and irreversible. Birds, sea mammals, fish and several marine invertebrate species are among the groups most impacted, and in some cases the whole food chain is affected. Oil spills can negatively influence the physiology, immunology, and development of some organisms, but their most evident effect is usually an important decrease or disappearance of populations of marine fauna and flora within the affected area. Linked to the damage caused to the environment are the high costs to fisheries, related industries, and tourism in the affected areas.

### 1.2 Problem Statement

Oil pollution in water bodies caused by industrial discharge, marine transportation, and accidental oil spills poses a serious threat to aquatic ecosystems, human health, and economic activities such as fisheries and tourism. Existing oil spill recovery methods are often expensive, energy-intensive, labour-dependent, and inefficient, with limited recovery rates and delayed response time. Many conventional systems rely on grid power and lack real-time monitoring, making them unsuitable for remote or continuous operation. Therefore, there is a critical need for a sustainable, cost-effective, and automated solution that can efficiently remove floating oil from water surfaces using renewable energy and smart IoT-based monitoring to minimize environmental damage.

### **1.3 Scopes of use**

This project helps in significantly reducing oil wastage by efficiently separating and recovering floating oil from water surfaces. The recovered oil can be safely collected and reused or disposed of properly, minimizing resource loss and environmental contamination.

Once the system is installed, it operates automatically without continuous human intervention. The belt-type oil skimmer accurately separates oil from water due to its oleophilic belt mechanism, ensuring reliable performance. With solar power and IoT integration, the system enables continuous, precise, and eco-friendly oil separation, making it suitable for industrial effluent treatment, marine applications, and wastewater management systems.

### **1.4 Objectives**

We have some specific objectives for this project and they are pointed below:

- To Study, Design and Construction a Solar powered Belt Type Oil Skimmer.
- To reduce oil pollution and oil wastage by recovering floating oil efficiently.

### **1.5 Work Flow Diagram**

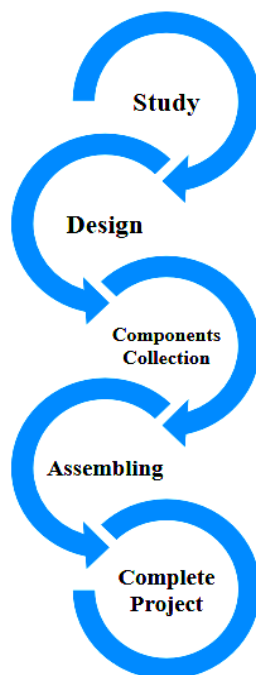

Figure 1.1 : Work Flow Diagram

The given image represents the project development flow. It begins with the study phase, where environmental issues and existing solutions are analyzed. This is followed by design, focusing on system structure and operation. Next is components collection, where required hardware is gathered. Assembling integrates all parts into a functional unit, leading to the complete project, which delivers a sustainable solution for oil pollution control.

# **CHAPTER 2**

## **LITERATURE REVIEW**

### **2.1 Introduction**

This chapter is arranged on Literature Review. Here's a look at some of last year's literature, like our project. By reading them, we can overcome the mistakes of the previous project and make a more effective project.

### **2.2 Related Research/ Works**

M.F. Khalil [1] discussed about Oil spill recovery using a rotating drum skimmer covered with a sponge layer was tested experimentally under a variety of operating conditions. The tests were carried out on two different diameter drums. The results show that the sponge-covered surface outperforms the standard steel surface in terms of oil recovery, regardless of the viscosity of the oil collected. When both drums were operated under the same conditions, the sponge covered drum collected 24% more oil than the plain steel drum.

M.Pavan Kumar [2] according to him An oil skimmer is a device used to remove floating oil from a liquid Medium. Water molecules are more attached to each other than oil molecules because they do not mix. Belt is used as the skimming medium in this case. The skimming medium runs over the surface of the water, bringing out oil with a small amount of water.

M.A.Khodary[3] discussed The effect of disc material and surface roughness on the rate and efficiency of oil recovery. Steel, plastic, and woven fabric were used as materials, and two types of oil were used, SAE50 and Used car engine oil. The rate of oil recovery was discovered to increase with increasing disc rotational speed. Depending on disc rotational speed and disc type, the rate of oil recovery ranged from 88 for SAE50 oil and from 89 for used oil.

Md.Ansar Khan [4] he discussed about To recover floating oil from the water's surface, a system with a high recovery rate in a dynamic water body is required. We proposed a smart oil skimmer with two circular disc Mechanisms and a user-controlled smartphone IoT (Internet of Things) data monitoring and controlling system in this paper.

Raj Maisuriya [5] discussed about the project's goal is to design a belt-type oil skimmer that removes oil effluent from water. Pollution has caused numerous environmental issues. By removing the oil from the water, it becomes oil-free. There are two types of oil skimmer: oleophilic and non-oleophilic. The oleophilic skimmer is distinguished not by its operations, but by the component used to collect oil, which is a belt. It is capable of removing even a thin floating layer of oil from water. This is primarily due to the belt's synthetic fiber material. The belt in a belt type oil skimmer absorbs the oil from the water and collects it in a storage tank.

R.Manivel[6] according to him the basic principle is that separating oil from water using an oil skimmer and coated materials such as Teflon or carbon is more sticky to the oil than water is. Teflon is used as a sticky material in the process of recovering oil from the surface of water, and the main component of the system is the Roller. Sheet metal is used for the roller part. The surface of the roller object is coated with a material similar to Activated carbon, Teflon. The surface of the roller object is coated with a material similar to Activated carbon, Teflon. If the oil becomes stuck on the rolling drum, it will rotate along with the drum. The scrapper attached to the collecting tank scrapes the oil stick on the drum.

S.Supriyono [7] discussed about The oil skimmer system consists of a rotary disc that collects oil on the water's surface and two propellers that move the oil skimmer. The rotary disc and propeller are powered by a DC motor linked to a motor driver and an Arduino Mega as a controller. The oil skimmer also has a joystick for adjusting the rotation speed of the rotary disc and controlling the movement of the oil skimmer. According to the testing results, the oil skimmer can take and separate oil on the water's surface at a separation speed.

### **2.3 Summary**

The above has been discussed in detail in the past few literature's which has given us a lot of motivation to do this project.

# **CHAPTER 3**

## **HARDWARE AND SOFTWARE ANALYSIS**

### **3.1 Introduction**

In this section, we will discuss elaborately about “ Solar powered Belt Type Oil Skimmer” and the component description, features, working procedure of our all equipment. The system hardware fabricates composed of micro-controller unit, power unit, source unit, power store unite and many more related components.

### **3.2 Hardware and Software**

#### **Hardware**

- Gear Motor
- Pully
- Bearing
- Conveyor Belt
- Solar Panel
- Battery
- Buck Conveter
- Node MCU
- Relay Module

#### **Software**

- Ardiono IDE
- Easy EDA

### **3.3 DC Gear Motor**

A DC gear motor combines a DC motor with a gearbox to deliver controlled speed and torque, making it ideal for applications requiring precise movement and power. The motor converts electrical energy into mechanical motion, while the gearbox reduces speed and increases torque. This configuration enhances performance in robotics, automation, and industrial machinery. DC gear motors are available in a variety of sizes, voltages, and torque ratings to suit diverse needs. Their efficient and reliable operation, compact design,

and ability to handle varying load conditions make them a popular choice for tasks demanding accuracy and durability in motion control systems.



Figure 3.1: DC Gear Motor

#### **Specification**

- Voltage: 12V DC
- Gear ratio: 1/31
- No-load speed: 200RPM
- Rated Speed: 140RPM
- Rated torque: 10kg.cm
- Rated current: 2.5Amp

### **3.4 Conveyor Belt**

Conveyors are durable and reliable components used in automated distribution and warehousing, as well as manufacturing and production facilities. In combination with computer-controlled pallet handling equipment this allows for more efficient retail, wholesale, and manufacturing distribution. It is considered a labor-saving system that allows large volumes to move rapidly through a process, allowing companies to ship or receive higher volumes with smaller storage space and with less labor expense.



Figure 3.2: Conveyor Belt

Belt conveyors are the most commonly used powered conveyors because they are the most versatile and the least expensive.<sup>[1]</sup> Products are conveyed directly on the belt so both regular and irregular shaped objects, large or small, light and heavy, can be transported successfully. Belt conveyors are also manufactured with curved sections that use tapered rollers and curved belting to convey products around a corner. These conveyor systems are commonly used in postal sorting offices and airport baggage handling systems.

### **3.5 Pulley**

A pulley is a wheel on an axle or shaft that is designed to support movement and change of direction of a taut cable or belt, or transfer of power between the shaft and cable or belt. In the case of a pulley supported by a frame or shell that does not transfer power to a shaft, but is used to guide the cable or exert a force, the supporting shell is called a block, and the pulley may be called a sheave.

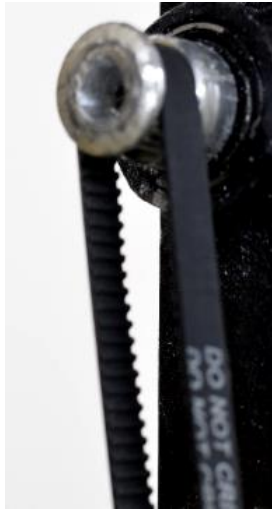

Figure 3.3: Pulley

Table 1: Pulley Specification

<b>Product Type</b>	<b>Motor Pulley</b>
Size	5mm,
Height	25mm
Outer diameter	12.2mm/0.48
Pitch Diameter	12.7mm/0.5

### **3.6 Bearing**

A bearing is a mechanical component designed to reduce friction and support the smooth movement of rotating or sliding parts in machinery. By minimizing resistance between surfaces, bearings enhance efficiency and extend the lifespan of equipment. They come in various types, including ball bearings, roller bearings, and plain bearings, each tailored to specific load and motion requirements. Bearings are essential in applications ranging from automotive and industrial machinery to household appliances and aerospace systems. Made from durable materials like steel or ceramics, they ensure reliability, precision, and stability in dynamic environments, enabling machines to operate efficiently under various conditions.



Figure 3.4: Bearing

### Specification

Table 2: Specification of Bearing

Type	Ball, Roller, Needle, or Plain Bearing.
Material	Steel (Chrome/Stainless), Ceramic, or Composite.
Load Capacity	Dynamic (C) and Static (C <sub>0</sub> ) ratings.
Dimensions	Bore Diameter (ID), Outer Diameter (OD), and Width.
Speed	Maximum RPM limit.
Lubrication	Greased, oil-lubricated, or sealed.
Sealing	Open, shielded, or sealed design.
Temperature Range	Typically -40°C to 150°C

### 3.7 Solar Panel

A 6V 6W solar panel is a compact, versatile power source using mono/polycrystalline cells for efficient charging of small devices like toys, lights, or batteries, featuring durable, often waterproof builds (ETFE/epoxy), and suitable for DIY projects, offering around 6V output with about 1A current, perfect for low-power, off-grid needs.

Solar cell modules produce electricity only when the sun is shining. They do not store energy, therefore to ensure flow of electricity when the sun is not shining, it is necessary to store some of the energy produced. The most obvious solution is to use batteries, which chemically store electric energy. Batteries are groups of electro chemical cells (devices that convert chemical energy to electrical energy) connected in series.



Figure 3.5: Solar Panel

Battery cells are composed of two electrodes immersed in electrolyte solution which produce an electric current when a circuit is formed between them. The current is caused by reversible chemical reactions between the electrodes and the electrolyte within the cell. Batteries that are re-chargeable are called secondary or accumulator batteries. As the battery is being charged, electric energy is stored as chemical energy in the cells. When being discharged, the stored chemical energy is being removed from the battery and converted to electrical energy. In East-Africa, the most common type of secondary battery is the Lead-acid battery .

### 3.8 Battery

Lithium batteries are primary batteries that have metallic lithium as an anode. These types of batteries are also referred to as lithium-metal batteries. They stand apart from other batteries in their high charge density and high cost per unit. Depending on the design and chemical compounds used, lithium cells can produce voltages from 1.5 V (comparable to a zinc-carbon or alkaline battery) to about 3.7 V .



Figure 3.6: 3.7V Battery

Disposable primary lithium batteries must be distinguished from secondary lithium-ion or a lithium-polymer, which are rechargeable batteries. Lithium is especially useful, because its ions can be arranged to move between the anode and the cathode, using an intercalated lithium compound as the cathode material but without using lithium metal as the anode material. Pure lithium will instantly react with water, or even moisture in the air; the lithium in lithium ion batteries is in a less reactive compound .

Lithium batteries are widely used in portable consumer electronic devices. The term "lithium battery" refers to a family of different lithium-metal chemistry, comprising many types of cathodes and electrolytes but all with metallic lithium as the anode. The battery requires from 0.15 to 0.3 kg of lithium per kWh. As designed these primary systems use a charged cathode, that being an electro-active material with crystallographic vacancies that are filled gradually during discharge.

### Product Specification

Table 3 : Battery Specification

Voltage	3.7 V
Product Type	Lithium-Ion
Battery Capacity	2200mAh
Weight	45 g
Model Number	ICR 18650

### 3.9 Buck Converter

A buck converter is a DC–DC step-down power converter that reduces input voltage to a lower output voltage efficiently. It works as a switched-mode power supply using a transistor, diode (or synchronous switch), inductor, and capacitor. The inductor opposes the input voltage, while filters reduce ripple and provide a smooth DC output.



Figure 3.7: DC -DC Buck Converter

DC-DC Buck Converter Step Down Module LM2596 Power Supply is a step-down(buck) switching regulator, capable of driving a 3-A load with excellent line and load regulation. These devices are available in fixed output voltages of 3.3 V, 5 V, 12 V, and an adjustable output version. The LM2596 series operates at a switching frequency of 150kHz, thus allowing smaller sized filter components than what would be required with lower frequency switching regulators.

### Specifications of DC-DC Buck Converter Step Down Module LM2596 Power Supply

Table 4: Buck Converter Specification

Conversion efficiency	92% (highest)
Switching frequency	150KHz
Output ripple	30mA9maximum)
Load Regulation	$\pm 0.5\%$
Voltage Regulation	$\pm 0.5\%$
Dynamic Response speed	5% 200uS
Input voltage	4.75-35V
Output voltage	1.25-26V(Adjustable)
Switching Frequency	150KHz
Module Properties	Non-isolated step-down module (buck)

### 3.10 Node MCU

Node MCU is an open source firmware for which open source prototyping board designs are available. The name "Node MCU" combines "node" and "MCU" (micro-controller unit). and built on the Espressif Non-OS SDK for ESP8266. It uses many open source projects, such as lua-cjson and SPIFFS. Due to resource constraints, users need to select the modules relevant for their project and build a firmware tailored to their needs. Support for the 32-bit ESP32 has also been implemented.

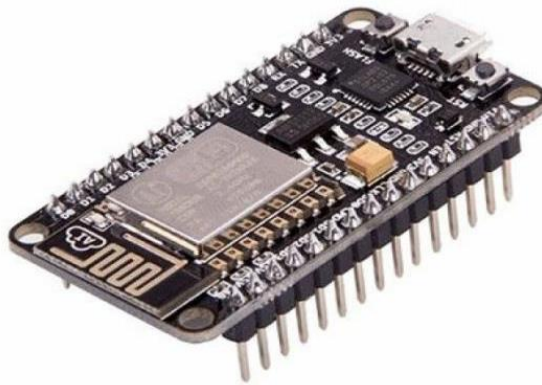

Figure 3.8: Node MCU

The prototyping hardware typically used is a circuit board functioning as a dual in-line package (DIP) which integrates a USB controller with a smaller surface-mounted board containing the MCU and antenna. The choice of the DIP format allows for easy prototyping on breadboards. The design was initially based on the ESP-12 module of the ESP8266, which is a Wi-Fi SoC integrated with a Tensilica Xtensa LX106 core, widely used in IoT applications. This is an open source IoT platform. It includes firmware which runs on the ESP8266 Wi-Fi SoC from Espressif Systems, and hardware which is based on the ESP-12 module. The term "Node MCU" by default refers to the firmware rather than the development kits. The firmware uses the Lua scripting language. It is based on the eLua project, and built on the Espressif Non-OS SDK for ESP8266. Node MCU was created shortly after the ESP8266 came out.

### 3.11 Relay Module

A relay is an electrically operated switch. Many relays use an electromagnet to mechanically operate a switch, but other operating principles are also used, such as solid-state relays. Relays are used where it is necessary to control a circuit by a separate low-power signal, or where several circuits must be controlled by one signal. The first relays were used in long distance telegraph circuits as amplifiers: they repeated the signal coming in from one circuit and re-transmitted it on another circuit. Relays were used extensively in telephone exchanges and early computers to perform logical operations.

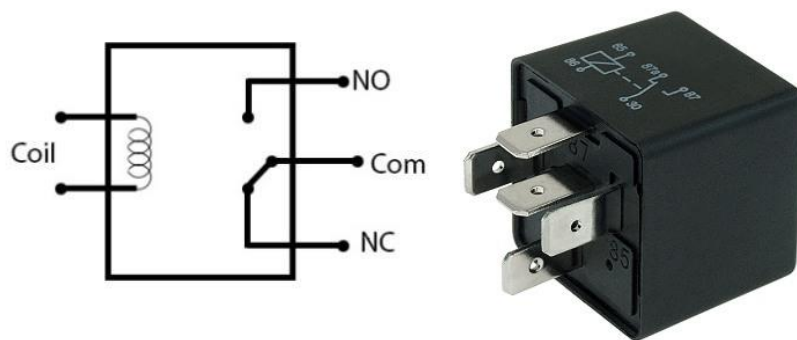

Figure 3.9: Relay

#### Mains voltage connections:

In relation to mains voltage, relays have 3 possible connections:

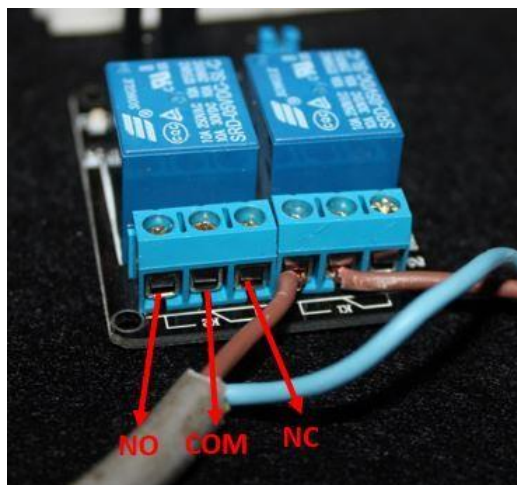

Figure 3.10: Pin diagram of Relay Module

**COM:** Common pin

**NO (Normally Open):** There is no contact between the common pin and the normally open pin. So, when you trigger the relay, it connects to the COM pin and supply is provided to a load

**NC (Normally Closed):** There is contact between the common pin and the normally closed pin. There is always connection between the COM and NC pins, even when the relay is turned off. When you trigger the relay, the circuit is opened and there is no supply provided to a load.

### Pin wiring

The connections between the relay module and the Arduino are really simple:



Figure 3.11: Main Voltage Connection

Table 5: Pin Wiring of Relay Module

<b>GND</b>	Goes to ground
<b>IN1</b>	Controls the first relay (it will be connected to an Arduino digital pin)
<b>IN2</b>	Controls the second relay (it should be connected to an Arduino digital pin if you are using this second relay. Otherwise, you don't need to connect it)

# SOFTWARE

## 3.12 Arduino IDE

The digital microcontroller unit named as Arduino Nano can be programmed with the Arduino software IDE. There is no any requirement for installing other software rather than Arduino. Firstly, Select "Arduino Nano from the Tools, Board menu (according to the microcontroller on our board). The IC used named as ATmega328 on the Arduino Nano comes pre burned with a boot loader that allows us to upload new code to it without the use of an external hardware programmer.

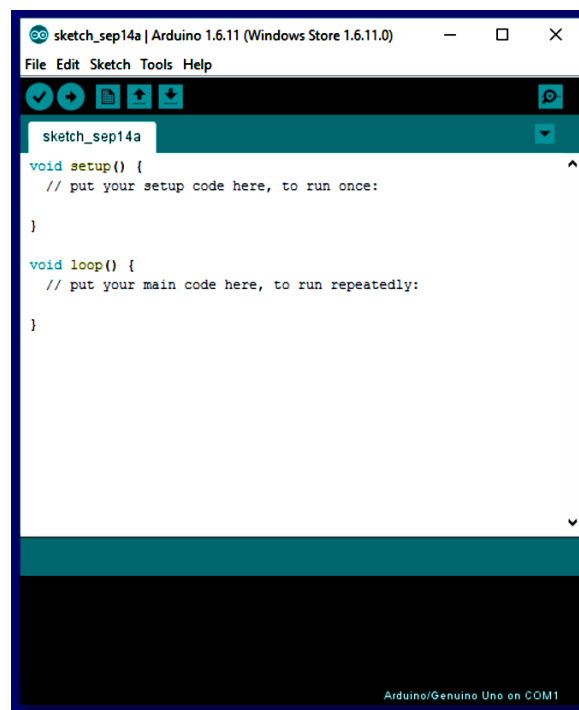

Figure 3.12: Arduino Software Interface IDE

On Rev1 boards: connecting the solder jumper on the back of the board (near the map of Italy) and then resetting the 8U2. On Rev2 or later boards: there is a resistor that pulling the 8U2/16U2 HWB line to ground, making it easier to put into DFU mode. The Arduino Nano is one of the latest digital microcontroller units and has a number of facilities for communicating with a computer, another Arduino, or other microcontrollers. The ATmega328 provides UART TTL at (5V) with serial communication, which is available on digital pins 0 -(RX) for receive the data and pin no.1 (TX) for transmit the data. An ATmega16U2 on the board channels this serial communication over USB and appears as

a virtual com port to software on the computer. The '16U2 firmware uses the standard USB COM drivers, and no external driver is needed. However, on Windows, an .in file is required. The Arduino software includes a serial monitor which allows simple textual data to be sent to and from the Arduino board.

The RX and TX LEDs on the board will flash when data is being transmitted via the USB-to-serial chip and USB connection to the computer (but not for serial Communication on pins 0 and 1). A Software Serial library allows for serial communication on any of the Nano's digital pins. The ATmega328 also supports I2C (TWI) and SPI communication. The Arduino software includes a Wire library to simplify use of the I2C bus. Arduino programs are written in C or C++ and the program code written for Arduino is called sketch. The Arduino IDE uses the GNU tool chain and AVR Lab to compile programs, and for uploading the programs it uses avrdude. As the Arduino platform uses Atmel microcontrollers, Atmel's development environment, AVR Studio or the newer Atmel Studio, may also be used to develop software for the Arduino.

# CHAPTER 4

## SYSTEM ARCHITECTURE

### 4.1 Introduction

The project objectives, methods, literature evaluation, and other details were all clarified in the preceding chapter. The methodology, System Design, block diagram, circuit diagram, Working principle, and final project instrument cost analysis will all be covered in this chapter.

### 4.2 Methodology

Our methodologies for the project:

- Creating an idea for design and construction of an Solar powered Belt Type Oil Skimmer. And designing a System basic drawing, block diagram & circuit diagram to know which components we need to construct it.
- Setting up all the components in a PCB board & then soldering. Lastly, assembling all the blocks in a board and to run the system & for checking purposes.

### 4.3 System Design

The basic design of the Solar Based Belt Type Oil Skimmer with IoT System consists of a compact, floating structure that supports a belt-type oil skimming mechanism. An oleophilic conveyor belt continuously rotates over the water surface, selectively absorbing floating oil while repelling water. The absorbed oil is scraped off using a wiper mechanism and collected in a storage container. The system is powered by a solar panel connected to a battery through a charge controller, ensuring uninterrupted operation in off-grid conditions. A DC motor drives the belt mechanism. An IoT module monitors key parameters such as motor operation, oil collection level, and battery status, transmitting data wirelessly for real-time monitoring and control.

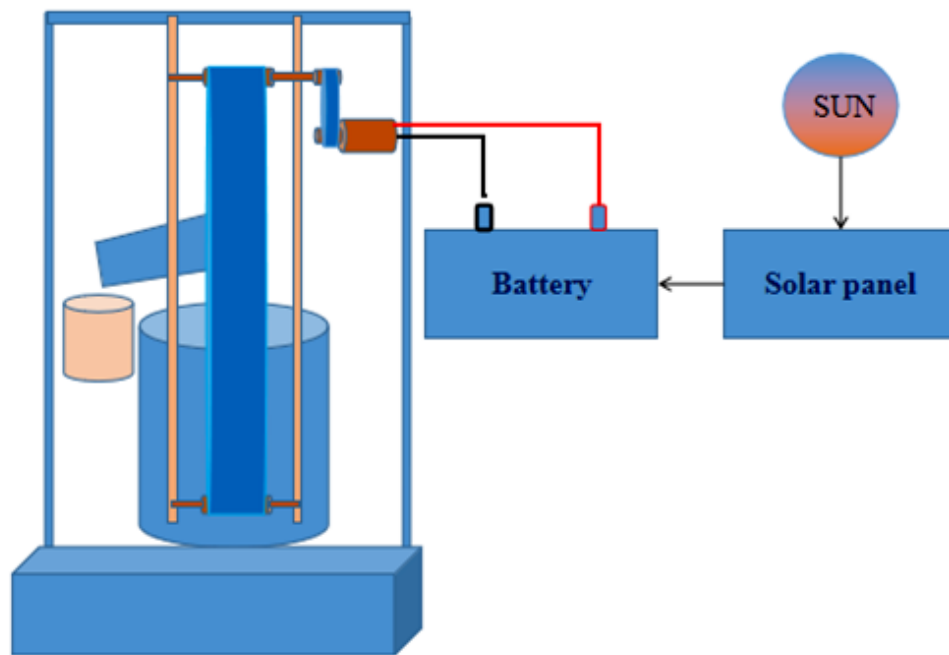

Figure 4.1: Basic Drawing of this System

#### 4.4 Block Diagram

Here is the block diagram of the Solar powered Belt Type Oil Skimmer with all the essential components. All of the components are shown in below as a block in this diagram. Here we use Arduino Nano for main brain of our project. Other equipment's are attached with this micro-controller and work together for perform as our desire outcome.

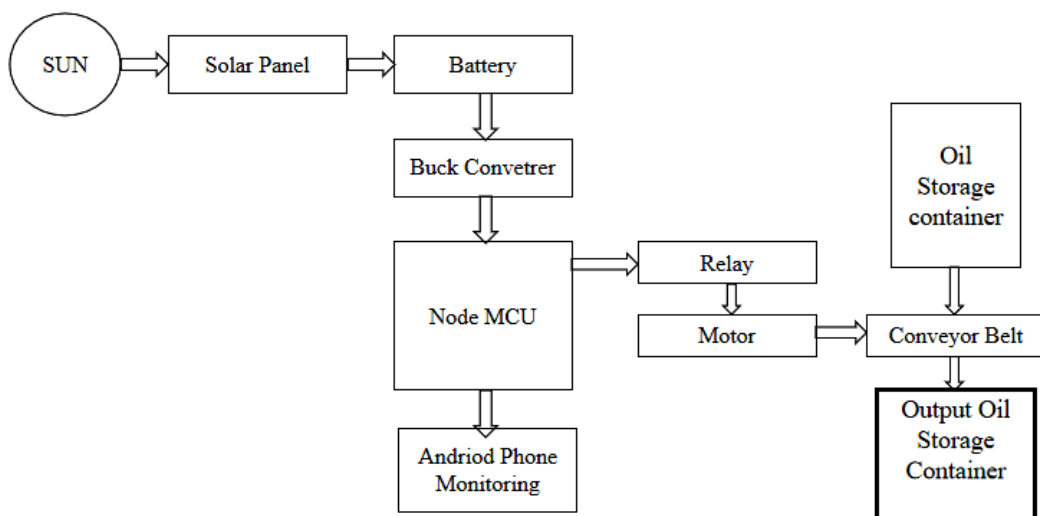

Figure 4.2: Block Diagram of Oil Skimmer .

## 4.5 Working Principle

The Solar Based Belt Type Oil Skimmer with IoT System operates using renewable energy and an automated mechanical separation process. A solar panel converts sunlight into electrical energy, which is stored in a battery for continuous operation. To ensure a constant and safe power supply to electronic components, a buck converter is used to provide stable voltage. The NodeMCU acts as the central controller of the system, managing motor operation and enabling IoT-based monitoring.

When the system is activated, the relay module, controlled by the NodeMCU, switches the DC motor ON or OFF. The motor drives the conveyor belt, which is made of an oleophilic material that selectively attracts and absorbs floating oil from the water surface while rejecting water. As the belt rotates, the collected oil is scraped off and directed into a storage container. The NodeMCU can transmit system status and operational data to a cloud platform, allowing remote monitoring and efficient oil recovery with minimal human intervention.

## 4.6 Cost Analysis

Table 6: Component's Name and Price

Sl. No	Components Name	Specification	Quantity	Unit Price	Total Price
1	Battery	3.7V	3	100	300
2	Gear Motor	12V, 100 RPM	1	880	880
3	Pulley		1	300	300
4	Bearing		2	150	300
5	Frame			3000	3000
6	Solar panel	6V, 6Watt	1	1100	1100
7	Buck Converter	LM2596	1	300	300
8	Node MCU	ESP-32	1	800	800
9	Relay Module		1	300	300
10	Others				2500
Total					9780/=

Table 7: Component's Name and Market Price

Sl. No	Components Name	Specification	Quantity	Unit Price	Total Price
1	Battery	12V	1	1400	1400
2	Gear Motor	12V, 100 RPM	1	1200	1200
3	Pulley		1	300	300
4	Bearing		2	300	600
5	Frame			5500	5500
6	Solar panel	6V, 6Watt	1	1500	1500
7	Buck Converter	LM2596	1	500	500
8	Node MCU	ESP-32	1	1300	1300
9	Relay Module		1	450	450
10	Others				3500
Total					16,250/=

If We had purchased this project as a ready-made system from an external third party or vendor, an additional cost of approximately **BDT 15,000–17,000** would have been incurred, resulting in a **total project cost of around BDT 35,000**.

# CHAPTER 5

## RESULT ANALYSIS

### 5.1 Project Outcome

After finally completing this project, we ran it & we observed the output of this project. We can see that it is working well as expected. After making our project we observe it very careful. It works as we desire. Our project give output perfectly and all equipment are work perfectly. We check how much it works and we get perfect output from this project.

- Finally, we have completed our project successfully & check our project its run accurately according to our objective.
- At first, we start our system.
- The system successfully separated floating oil from water using the belt-type conveyor mechanism.
- Solar power operation reduced dependency on external electrical sources and enabled continuous functioning.
- The buck converter provided stable voltage, ensuring safe and reliable performance of NodeMCU and sensors.
- The conveyor belt and motor operated smoothly, allowing consistent oil collection with minimal water intake.
- Oil wastage was significantly reduced by effective recovery and storage of collected oil.
- The IoT-based monitoring using NodeMCU allowed real-time system status observation and improved control.

Overall, the project demonstrated a cost-effective, eco-friendly, and automated solution for oil pollution control.

## Data Analysis Table

Time (min)	Materials	Oil Storage
5	Oil & Water	56 ml
10	Oil & Water	112 ml
15	Oil & Water	168 ml
5	Clean Water	56 ml
10	Medium Garbage Water	42 ml
15	Garbage Water	26.5 ml

### Calculation:

Reserve tank capacity : 5 liter

Water : 3.5 liter

Oil : 1.5 liter

Total liquid : 5 liter

Total oil = 1.5 liter

Oil skimmed in 5 min

$$= 1.5 \times 0.80$$

$$= 1.2 \text{ liter}$$

Remaining oil

$$= 1.5 - 1.2$$

$$= 0.3 \text{ liter}$$

### Efficiency calculation:

$$\text{Efficiency} = \frac{\text{Oil Skimmed}}{\text{Total Oil}} \times 100$$

$$= \frac{1.2}{1.5} \times 100$$

$$= 80\%$$

## 5.2 Complete Project Prototype



Figure 4.1: Project Progress Image

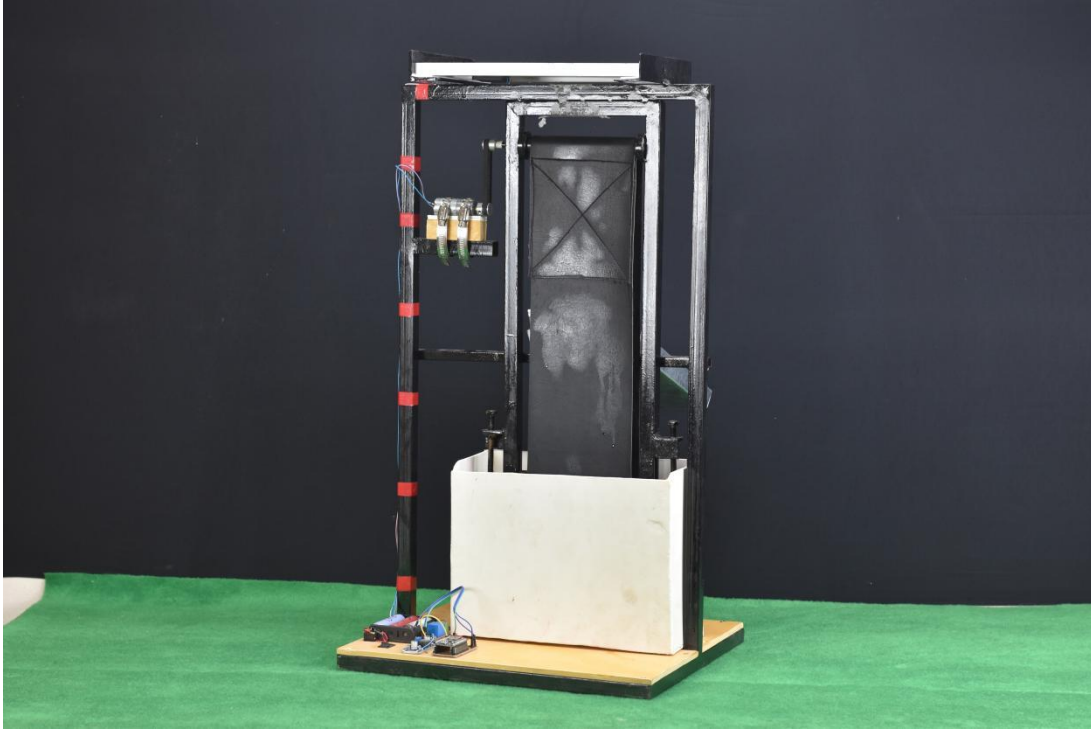

Figure 4.2: Final Project image

The project operates using solar energy to power a belt-type oil skimming mechanism. A solar panel charges the battery, and a buck converter provides stable voltage to the nodemcu and motor. The nodemcu controls the relay to drive the motor, rotating the conveyor belt. The oleophilic belt absorbs floating oil from water, which is then scraped off and collected, while system status is monitored through iot.

# CHAPTER 6

## CONCLUSION

### 6.1 Conclusion

The Solar Based Belt Type Oil Skimmer with IoT System successfully demonstrates an eco-friendly, cost-effective, and automated method for removing floating oil from water surfaces. The integration of a belt-type skimmer with solar power ensures continuous operation in remote or off-grid locations, reducing reliance on conventional electricity. The oleophilic conveyor belt efficiently attracts and separates oil, while the collected oil is safely stored for reuse or disposal, minimizing environmental contamination and oil wastage.

### 6.2 Future Work

We are thinking about adding many features to our project in the future to get more desirable outcomes. Some of the steps that we are thinking about taking are given below:

- In future development this project can be developed by sensor system.
- In future we will add some sensor to measure oil quantity in container.

### 6.3 Advantages

There are many advantages of our project because of its accuracy. Some of the advantages are pointed out below:

- An oil skimmer helps reduce that threat by removing the oil.
- Less skill technicians is sufficient to operate.
- Less time and more profit.
- Suitable for remote and off-grid locations
- Eco-friendly and pollution-free operation
- IoT monitoring enables remote supervision
- Ease of operation

## **6.4 Application**

The application areas for this project in this modern and practical world are huge and some of these are given below:

- Cleaning industrial wastewater containing oil
- Oil recovery in marine environments and harbors
- Effluent treatment plants for factories and workshops
- Oil spill management in rivers, lakes, and ponds

## **6.5 Limitation**

Through the project has many advantages it has also some limitation, they are given below:

- Solar performance drops in cloudy or rainy conditions.
- This project can now be only used for small scale purposes
- To get all notification mobile and project must be connected with the internet.

## REFERENCES

- [1] M.F. Khalil a, Ibrahim El-Boghdady , E.R. Lotfya “Oil-recovery performance of a sponge-covered drum Skimmer” Alexandria Engineering Journal, Elsevier, doi 1110-0168,page no:12653-12660,December 2021
- [2] M. Pavan Kumar, K. Prithvi Raj<sup>2</sup>, B.Sridhar, Ch. Mohan Sumanth<sup>4</sup>, Dr. K. Srividya , “Oil Separator Skimmer” International Journal of Research in Engineering and Science, Volume:9 Issue 7 ISSN:2320-9364, Page No : 568,July2021.
- [3] D. A. El-Gayar & M. A. Khodary & M. H.Abdel-Aziz & M. F. Khalil , “ Effect of disk skimmer material and oil viscosity on oil spill recovery” Alexandria Engineering Journal ,Water Air Soil Pollute ,doi 232:193, page no:193,April 2021.
- [4] Md.Ansar khan ,Md. Golam Mostafa , Md. Mizanul hoque “Implementing and Improving The IoT Based Weather Monitoring and Controlling Double Discs type Oil Skimmer” International Conference on Robotics, Electrical and Signal Processing Techniques, ICREST,Doi10.1109 Page no:499-503, May2021.
- [5] Raj Maisuriya, Vatsal Maisuriya, “Design and development of belt type oil skimmer” Journal of Ecology , ISSN: 2278-2230 Volume 9, Issue 2 page no:4-10, March 2020.
- [6] Manivel , R. Sivakumar , “Boat type oil recovery skimmer.” Science direct Elsevier, doi 10.1016, ISSN638- 265, Pageno:2214-7853, May 2019.
- [7] S.Supriyono, D.T Nurrohman “ Floating Oil Skimmer Design Using Rotary disc method”, IOP publishing, doi 10.1088 , ISSN : 1742-6596 ,page no:1450 ,June 2019.