

Performance and Environmental Impact Assessment of an Electric Bicycle

A thesis report submitted to the department of mechanical engineering for the partial fulfillment of the degree of Bachelor of Science in mechanical Engineering.

A Thesis By

SUMON SHAKE

ME2202027139

MD. SAAD BIN ASHFAK

ME2003022030

MD. ZAHID HASAN

BME2001020582

Supervised By

M.I.WASHIF RAHMAN

Lecturer

DEPARTMENT OF MECHANICAL ENGINEERING



DEPARTMENT OF MECHANICAL ENGINEERING
SONARGAON UNIVERSITY (SU)
DHAKA-1215, BANGLADESH
JANUARY, 2026

LETTER OF TRANSMITTAL

January, 2026

To

M.I. Washif Rahman

Lecturer

Department of Mechanical Engineering.

Sonargaon University

Subject: Submission of Project Report.

Dear Sir,

We are pleased to submit the project report on “Development, Performance and Environmental Impact Assessment of an Electric Bicycle”.

It was a great pleasure to work on such an important topic. This project has been done as per instruction of your supervision and according to the requirements of the Sonargaon University.

We expect that the project will be accepted by the concerned authority we will remain happy to further explanation that you may feel necessary in this regard.

Thank You

Sincerely yours,

Sumon Shake
ME2202027139

Md. Saad Bin Ashfak
ME2003022030

Md. Zahid Hasan
BME2001020582

DECLARATION

We do hereby solemnly declare that, the work presented here in this project report has been carried out by us and has not been previously submitted to any University/ Organization for award of any degree or certificate We hereby ensure that the works that has been prevented here does not breach any existing copyright. We further undertake to indemnify the university against any loss or damage arising from breach of the foregoing obligation.

Sumon Shake
ME2202027139

Md. Saad Bin Ashfak
ME2003022030

Md. Zahid Hasan
BME2001020582

Supervisor:
M.I. Washif Rahman
Lecturer
Department of Mechanical Engineering
Sonargaon University(SU)
Dhaka,Bangladesh
January, 202

TABLE OF CONTENTS

LETTER OF TRANSMITTAL.....	2
DECLARATION	3
ACKNOWLEDGEMENT.....	6
ABSTARCT.....	8

CHAPTER 1

INTRODUCTION

1.2 Background of the Study	9
1.3 Problem Statement	9
1.4 Objectives	9
1.5 Structure of the Project.....	10

CHAPTER 2

LITERATURE REVIEW

Previous Studies on E-Bike Performance, Efficiency & Environmental Impact:	11
--	----

CHAPTER 3

METHODS/MATERIALS AND METHODOLOGY

3.1 Working Principle of an Electric Bicycle	12
3.2 Main Components.....	13
MTB Alloy Frame.....	13
Suspension Alloy Crown Fork.....	14
Hub Motor (36v, 250W)	14
Battery	15
Speed meter	15
E-throttle	16
E-Brake	16
Steel Handle bar	17
7-Speed Block Multiple Freewheel, 14-28 Tooth.....	17

Steel Chain wheel & Crank:.....	18
Front Derailleur	18
Rear Derailleur	19
Block Diagram	19
Schematic Diagram	20
Our Final Project View	20
Project Cost Calculation:.....	22

CHAPTER 4

PERFORMANCE STUDY

4.1 Electric Bicycle Performance Calculations	23
4.2 Sample Data Table:.....	27
4.2 Comparison with Conventional Bicycle, Electric Bicycle and Motorbike.....	30
4.3 Performance Comparison Summary	30
4.4 CO ₂ Emission Calculation	31
4.5 Final Numerical Comparison Table.....	32
4.6 Environmental Breakdown	34
4.7 Carbon Payback Comparison Table	35

CHAPTER 5

ENVIRONMENTAL IMPACT AND SUSTAINABILITY

5.1 Emission Reduction Study	37
5.2 Energy Savings	37
5.3 Environmental Benefits of Electric Bicycles.....	38
5.4 Suitability in Bangladesh Context	38
5.5 Sustainability Aspects.....	39

CHAPTER 6

RESULT AND DISCUSSION

Performance Results	41
Environmental Impact Results	41
Discussion	41

CHAPTER 7 CONCLUSION

Conclusion	41
Future Scope.....	41
REFERENCE.....	42

FIGURE CONTENT

Figure 3.1: 26" MTB Alloy Frame	13
Figure 3.2: Suspension Alloy Crown Fork	14
Figure 3.3: Hub Motor	14
Figure 3.4: Battery (36V 10.4Ah).....	15
Figure 3.5: Speed Meter.....	15
Figure 3.6: E-throttle.....	16
Figure 3.7: E-Brake.....	16
Figure 3.8: Steel Handlebar	17
Figure 3.9: 7-Speed Block Multiple Freewheel, 14-28 Tooth.....	17
Figure 3.10: Steel Chain wheel & Crank	18
Figure 3.11: Front Derailleur	18
Figure 3.12: Rear Derailleur	19
Figure 3.13: Block Diagram of Our Project.....	19
Figure 3.14: Schematic Diagram of the Project	20

ACKNOWLEDGEMENT

First, we started in the name of almighty Allah. This thesis is accomplished under the

supervision of M.I Washif Rahman, Lecturer, Department of Mechanical, Sonargaon University. It is a great pleasure to acknowledge our profound gratitude and respect to our supervisor for this consistent guidance, encouragement, helpful suggestion, constructive criticism and endless patience through the progress of this work. The successful completion of this thesis would not have been possible without his persistent motivation and continuous guidance.

The authors are also grateful to Md. Mostofa Hossain, Head of the Department of Mechanical Engineering and all respect teachers of the Mechanical Engineering Department for their co-operation and significant help for completing the thesis work successfully.

Supervisor:

M.I. Washif Rahman

Lecturer

Department of Mechanical Engineering

Sonargaon University(SU)

Dhaka,Bangladesh

January, 2026

ABSTARCT

Electric bicycles (e-bikes) have emerged as an efficient and environmentally friendly mode of transportation, especially for short-distance urban travel. This study focuses on the performance and environmental impact assessment of an electric bicycle. Key performance parameters such as speed, range, energy consumption, battery efficiency, and operating cost were evaluated under real-world operating conditions. The environmental assessment compares greenhouse gas emissions and energy usage of the electric bicycle with conventional gasoline-powered two-wheelers. The results indicate that electric bicycles offer low energy consumption, reduced operating costs, and significantly lower carbon emissions. The findings highlight the potential of electric bicycles as a sustainable transportation solution for reducing environmental pollution and dependence on fossil fuels.

CHAPTER 1

INTRODUCTION

Rapid urbanization and increasing fuel consumption in Bangladesh have caused traffic congestion, air pollution, and high transportation costs, creating a need for sustainable mobility solutions. Electric bicycles offer an energy-efficient and environmentally friendly alternative for short-distance travel by using electric motor assistance with low power consumption and zero tailpipe emissions. This thesis assesses the performance and environmental impact of an electric bicycle by evaluating key parameters such as speed, range, energy efficiency, and power consumption, and examines its potential to reduce emissions and energy use, highlighting its suitability for sustainable transportation in Bangladesh.

1.2 Background of the Study

The growing demand for transportation in Bangladesh has led to increased fuel consumption, traffic congestion, and air pollution, particularly in urban areas. Conventional fuel-powered vehicles contribute significantly to greenhouse gas emissions and rising operating costs. Electric bicycles have emerged as a sustainable alternative for short-distance travel due to their low energy consumption, zero tailpipe emissions, and affordability. Understanding the performance characteristics and environmental benefits of electric bicycles is essential for evaluating their effectiveness as a viable transportation solution. Therefore, this study focuses on assessing the performance and environmental impact of an electric bicycle to support sustainable and energy-efficient mobility in Bangladesh.

1.3 Problem Statement

In Bangladesh, increasing dependence on fossil fuel-based transportation has resulted in high fuel consumption, traffic congestion, air pollution, and rising greenhouse gas emissions, particularly in urban areas. Although electric bicycles offer a potential solution due to their low energy consumption and minimal environmental impact, their performance characteristics and environmental benefits under local operating conditions are not well documented. There is a lack of systematic Study regarding speed, range, efficiency, and emission reduction of electric bicycles in comparison to conventional vehicles. Therefore, a comprehensive performance and environmental impact assessment of an electric bicycle is required to evaluate its feasibility and suitability as a sustainable transportation option in the context of Bangladesh.

1.4 Objectives

1. To evaluate the performance of an electric bicycle by analysing speed, range, energy efficiency, and power consumption under typical operating conditions.
2. To assess the environmental impact of the electric bicycle by comparing energy use and emission reduction with conventional fuel-based two-wheelers.
3. To determine the suitability of electric bicycles as a sustainable and cost-effective transportation option for urban use in Bangladesh.

1.5 Structure of the Project

The project is organized into the following chapters for clear understanding and systematic presentation:

1. **Introduction:** Overview of electric bicycles, importance, and study objectives.
2. **Literature Review:** Previous studies on performance, efficiency, and environmental impact of e-bikes.
3. **Materials and Methods:** Design, components, and methodology for performance testing.
4. **Performance Study:** Evaluation of speed, range, power consumption, and efficiency.
5. **Environmental Impact Assessment:** Study of energy savings, emission reduction, and sustainability.
6. **Results and Discussion:** Presentation and interpretation of experimental or simulated data.
7. **Conclusion & Future Scope:** Summary of findings, implications, and recommendations.

CHAPTER 2

LITERATURE REVIEW

Previous Studies on E-Bike Performance, Efficiency & Environmental Impact:

Electric bicycles (e-bikes) combine human power with electric motor assistance, enhancing mobility and making travel easier over longer distances. This increased efficiency has contributed to their growing adoption as a sustainable transport option worldwide. Researchers have developed methods to quantify energy efficiency and compare e-bikes with conventional bicycles, highlighting differences in energy consumption based on assisted pedalling and vehicle mass (Zhou et al., 2025).

Lifecycle analyses show that electric bicycles consume significantly less energy and emit far fewer greenhouse gases than conventional motorized vehicles such as motorcycles and cars. E-bikes can offer up to an order of magnitude lower energy use per distance travelled, underlining their potential to reduce urban transport emissions (Li et al., 2021).

Reviews of environmental performance demonstrate that electrification of two-wheelers, particularly e-bikes, generally results in lower pollution exposure and improved environmental performance compared to internal combustion engine vehicles. However, lifecycle emissions are influenced largely by battery production and electricity generation (Frey & Stump, 2015).

Recent bibliometric analyses indicate an evolving research focus on energy efficiency, performance evaluation, and environmental benefits of e-bikes, while also identifying gaps for future studies on sustainability and operational optimization (Wang et al., 2023).

These studies collectively suggest that electric bicycles can improve energy efficiency and reduce environmental impact compared to traditional vehicles, while also highlighting areas for region-specific research, such as urban transport conditions in Bangladesh.

Several researchers have examined the energy efficiency and performance characteristics of electric bicycles. Recent work by Zhang and Tak (2021) evaluated the power transmission efficiency in e-bike systems, highlighting that the design and efficiency of transmission components significantly influence overall performance and energy use of electric-assist bicycles, thereby affecting both rider experience and energy consumption patterns. In a similar vein, a 2025 study proposed an energy efficiency assessment method that uses real-world recorded data to determine tractive force and energy consumption per kilometre, showing that electric-assist bikes can reduce physical effort and contribute to broader transport adoption, although they consume more energy than traditional bicycles when assistance is constantly on.

Beyond direct emissions, travel behaviour studies indicate that e-bike usage can shift modal choices away from cars, potentially contributing to broader environmental benefits by reducing reliance on private vehicles. Scoping reviews show that e-bike adoption is associated with increased cycling frequency and reduced motorized travel, which can further decrease overall emissions and lead to healthier, more sustainable urban mobility patterns.

CHAPTER 3

METHODS/MATERIALS AND METHODOLOGY

3.1 Working Principle of an Electric Bicycle

The working principle of an electric bicycle (e-bike) is based on the integration of electrical and mechanical systems to assist human pedaling. The primary components include a battery, electric motor, controller, and pedal-assist system.

Battery: The battery, typically lithium-ion, stores electrical energy and supplies power to the motor. Voltage and capacity are selected based on desired speed, range, and load requirements.

Electric Motor: The motor converts electrical energy into mechanical energy to drive the rear or front wheel. Depending on the design, either hub motors or are used. The motor operates in response to throttle input or pedal-assist sensors.

Controller: The controller regulates the power flow from the battery to the motor. It processes inputs from the rider, such as pedal rotation or throttle position, and adjusts motor torque accordingly.

Pedal-Assist System: Pedal-assist sensors detect the pedaling force and cadence of the rider. This signal is transmitted to the controller, which modulates motor assistance to provide smooth and efficient riding.

Power Transmission: The combined torque from the rider and motor is transferred to the wheel via the chain or belt drive system. This hybrid propulsion reduces physical effort while improving speed and efficiency.

Experimental Approach:

Data on speed, battery voltage, current draw, and distance traveled will be collected using digital sensors and logging systems.

Efficiency will be calculated as the ratio of mechanical output (wheel torque \times speed) to electrical input (battery power).

Environmental impact will be assessed by comparing equivalent CO₂ emissions with a conventional bicycle and gasoline-powered vehicles.

This methodology provides a structured understanding of the e-bike's operation, enabling performance evaluation and sustainability assessment.

3.2 Main Components

- MTB Alloy Frame
- Suspension Alloy Crown Fork
- Hub Motor (36v, 250W)
- Battery(10.4AH)
- Speed Meter
- E-throttle
- E-brake
- Steel Handle bar
- 7 Speed Index 14-28 T for Multi Speed
- Steel Chain wheel & Crank
- Front Derailleur
- Rear Derailleur,

MTB Alloy Frame

The MTB alloy frame is the main structural component of the mountain bicycle, designed to support all mounted parts and withstand off-road riding conditions. Manufactured from lightweight aluminum alloy, the frame offers high strength, corrosion resistance, and reduced overall weight. Its geometry is optimized for stability, durability, and rider comfort, making it suitable for rough terrain and varied trail conditions.



Figure 3.1: 26" MTB Alloy Frame

Suspension Alloy Crown Fork

The suspension alloy crown fork is a front suspension component designed to absorb impacts and vibrations during off-road riding. It features an alloy crown for improved strength and reduced weight, contributing to better steering precision and durability. The suspension system enhances rider comfort, control, and front-wheel stability on rough and uneven terrain, making it suitable for mountain bicycles.



Figure 3.2: Suspension Alloy Crown Fork

Hub Motor (36v, 250W)

The 36V, 250W hub motor is an electric drive unit integrated into the bicycle wheel to provide propulsion assistance. It converts electrical energy from the battery into mechanical motion, supporting the rider during pedaling and reducing physical effort. Designed for efficiency and reliability, the hub motor offers smooth acceleration, low noise operation, and is suitable for urban commuting and light off-road riding.



Figure 3.3: Hub Motor

Battery

The 36V, 10.4Ah battery is the primary energy storage unit of the electric bicycle system. It supplies electrical power to the hub motor and electronic components, enabling motor-assisted operation. Designed for reliable performance, the battery provides adequate range, stable voltage output, and efficient energy delivery while maintaining a compact and lightweight structure suitable for bicycle integration.



Figure 3.4: Battery (36V 10.4Ah)

Speed meter

The speed meter is an electronic instrument used to measure and display the bicycle's real-time traveling speed. It receives input from wheel rotation sensors or the motor control system and presents the data on a digital display. The speed meter helps the rider monitor riding speed, ensure safe operation, and maintain compliance with speed regulations.



Figure 3.5: Speed Meter

E-throttle

The e-throttle is a control device used to regulate the power output of the electric bicycle motor. Operated by the rider through a twist or thumb mechanism, it sends signals to the motor controller to adjust speed and acceleration. The e-throttle provides smooth and responsive control, allowing the rider to manage motor assistance according to riding conditions.



Figure 3.6: E-throttle

E-Brake

The e-brake is a safety component integrated with the electric bicycle braking system. In addition to providing mechanical braking, it sends a signal to the motor controller to immediately cut off motor power when the brake is applied. This ensures safe operation by preventing unwanted acceleration during braking and improving overall rider control.



Figure 3.7: E-Brake

Steel Handle bar

The steel handlebar is a structural and functional component designed to provide strength, durability, and control. Manufactured from high-strength steel, it offers excellent load-bearing capacity, resistance to deformation, and long-term reliability. Its ergonomic form ensures comfortable handling while maintaining structural integrity under repeated use.

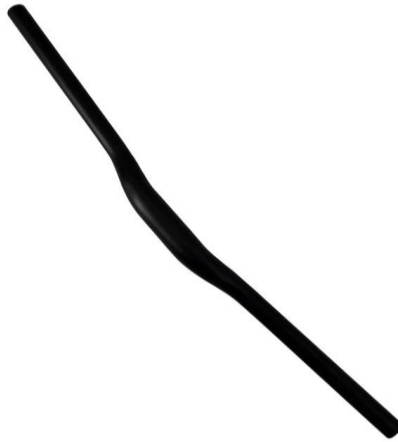

Figure 3.8: Steel Handlebar

7-Speed Block Multiple Freewheel, 14-28 Tooth

The 7-Speed Block Multiple Freewheel, 14-28 Tooth range enables smooth and precise gear shifting across multiple speed ratios. This configuration provides an optimal balance between low and high gear performance, improving efficiency, adaptability to varying terrain, and overall riding comfort.



Figure 3.9: 7-Speed Block Multiple Freewheel, 14-28 Tooth

Steel Chain wheel & Crank:

The steel chain wheel and crank assembly serves as the primary drivetrain component, converting rider pedaling into rotational motion to drive the bicycle. Made from high-strength steel, it offers durability, resistance to wear, and reliable power transmission under varying loads, ensuring efficient and long-lasting performance.



Figure 3.10: Steel Chain wheel & Crank

Front Derailleur

A front derailleur is a bicycle drivetrain component responsible for shifting the chain between the front chain rings. It is mounted near the crank set and operates by guiding the chain sideways when actuated by a shifter through a cable or electronic system. The front derailleur enables the rider to change gear ratios, improving pedaling efficiency across varying speeds and terrain.



Figure 3.11: Front Derailleur

Rear Derailleur

A rear derailleur is a key bicycle drivetrain component that shifts the chain across the rear sprockets (cassette). Mounted to the bicycle frame near the rear wheel, it moves the chain laterally to change gears and maintains proper chain tension through a spring-loaded mechanism. The rear derailleur allows precise gear selection, enabling efficient power transmission and smooth riding under different riding conditions.



Figure 3.12: Rear Derailleur

Block Diagram

Block diagram is a diagram where all equipment's are organized by block. This is a primary diagram of our system. Here we use Battery Charger, Battery, Power Electronic Converter, Hub Motor.

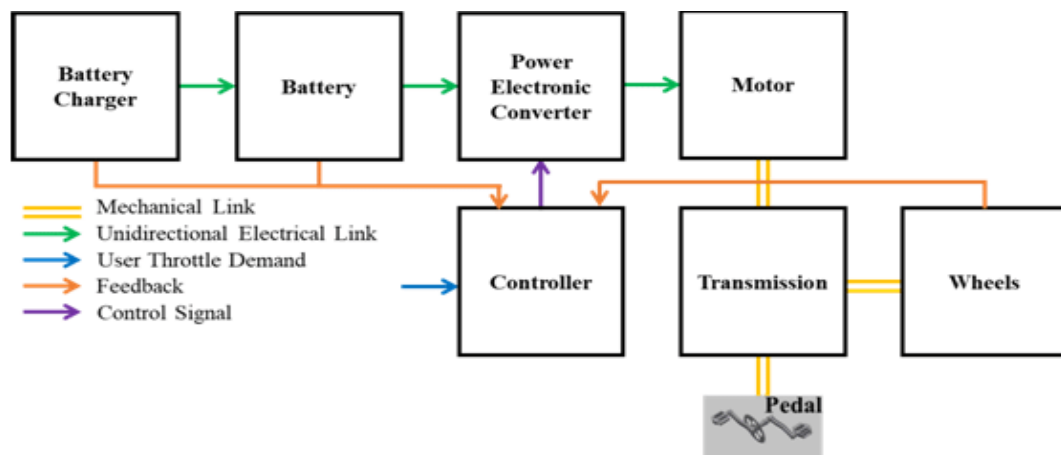

Figure 3.13: Block Diagram of Our Project.

Schematic Diagram

The schematic diagram here is representing the electrical circuit and the components of the project. Here we have used standardized symbols and lines.

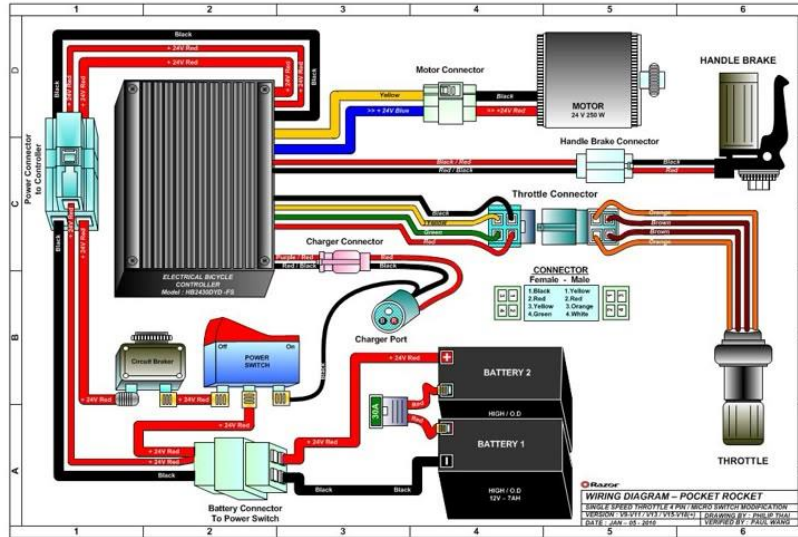

Figure 3.14: Schematic Diagram of the Project

Ref. [<https://www.pinterest.com/pin/605593481142096934/>]

Our Final Project View



Methodology for Performance Testing

The performance of the electric bicycle is evaluated through experimental and analytical methods:

1. **Speed Test:** Maximum and average speeds are measured over a standard urban distance.
2. **Range Test:** Distance covered on a single full battery charge is recorded under normal riding conditions.
3. **Power Consumption & Efficiency:** Energy consumed per kilometre is calculated using battery discharge data.
4. **Load Test:** Performance under different rider weights and inclines is assessed.
5. **Environmental Impact Assessment:** Energy savings and emission reductions are estimated by comparing e-bike operation with conventional fuel-based two-wheelers.

Project Cost Calculation:

SL	Description	Unit	Quantity	Amount
1	Bicycle Frame Alloy-26"	PCS	1	1520
2	Suspension FORK	PCS	1	1080
3	HEADSET	SET	1	65
4	SEAT BOLT-ALLOY-31.8MM-TRADE	SET	1	10
5	BB PART STL	SET	1	50
6	B. B. AXLE-STL-SF-BB01-5P-BOLT TYPE	PCS	1	40
7	ALLOY SPACER-TOP COVER TAPER TYPE	PCS	3	3
8	Handle bar 31.8X670MM-(Low-Raise) Alloy	PCS	1	220
9	STEM ALLOY	PCS	1	100
10	Saddle RBS-1202	PCS	1	220
11	Seat Post-Alloy 27.2X250MM	PCS	1	70
12	E-BIKE BREAK LEVER-22MM-2 FINGER	PAI	1	700
13	BRAKE SET-ALLOY	SET	1	500
14	BRAKE INNER CABLE	PCS	1	7
15	BRAKE INNER CABLE	PCS	1	8
16	FRONT DERAILLEUR- 6/7 SPD	PCS	1	80
17	REAR DERAILLEUR-TZ35 7-SPD	PCS	1	205
18	SHIFTER RIGHT-ST-EF-500-7 SPEED-BK	PCS	1	160
19	SHIFTER LEFT-ST-EF-500-7 SPEED-BK	PCS	1	280
20	BRAKE CABLE OUTER CASING	ROL	0.004	10
21	CHAIN	EA	108	95
22	FREEWHEEL-STL-FW-7SI-14-28T-BRN/BK	PCS	1	260
23	CHAINWHEEL	PCS	1	325
24	E-BIKE MOTOR- XF-36V 250WATT	PCS	1	12000
25	BATTERY (LITHIUM ION; 36V 7.8AH)	PCS	1	8000
26	ELECTRIC BIKE THROTTLE FOR 24 n 26	PAI	1	400
27	BICYCLE TUBE-NATURAL RUBBER	PCS	2	110
28	RIM TAPE-RUBBER-26X1.95-BLK	PCS	2	14
29	Tyre-26InX2.25 (D-2678)	PCS	2	285
30	Double Wall Silver Rim 26"	PCS	2	500
31	Bicycle Spoke With Nipple 256 Mm	PCS	0.5	40
32	FRONT HUB Disk Brake	PCS	1	95
33	KICK STAND-STL-ALLOY	PCS	1	190
34	MUDGUARD	SET	1	50
35	SPEED METER	PCS	1	700
36	Travelling Allowance			1300
37	Food Allowance			250
38	Printing			1500
			Total Cost	31442

CHAPTER 4

PERFORMANCE STUDY

4.1 Electric Bicycle Performance Calculations

(Flat Road Condition)

Given Data

Battery Voltage, $V = 36 \text{ V}$

Battery Capacity, $C = 10.4 \text{ Ah}$

Motor Rated Power, $P_m = 250 \text{ W}$

Wheel Size, 26 inch

Rider Weight = 70 kg

Bicycle Weight = 25 kg

Total Mass, $m = 95 \text{ kg}$

Average Speed, $v = 25 \text{ km/h}$

Road Condition: Flat

Electricity price = BDT 7.740 per kWh

Charger current output $I = 2 \text{ A}$

Battery Energy Calculation

$$E_{\text{battery}} = V \times \text{Ah}$$

$$E_{\text{battery}} = 36 \times 10.4 = 374.4 \text{ wh}$$

Motor Current Calculation

$$I = \frac{P}{V} = \frac{250}{36}$$

$$I = 6.94 \text{ A}$$

Charging Time

2 A charger

$$t = \frac{\text{Ah}}{I_{\text{charger}}} = \frac{10.4}{2}$$

$$t = 5.2 \text{ hours}$$

Wheel Geometry

Wheel diameter:

$$26 \text{ inch} = 0.66 \text{ m}$$

Wheel radius:

$$r = 0.33 \text{ m}$$

Wheel circumference:

$$C = \pi D = 3.1416 \times 0.66 = 2.07 \text{ m}$$

Wheel Rotational Speed

Convert speed to m/s

$$25 \text{ km/h} = 6.94 \text{ m/s}$$

Wheel RPM

$$\text{RPM} = \frac{v}{C} \times 60$$

$$\text{RPM} = \frac{6.94}{2.07} \times 60 = 201 \text{ RPM}$$

Motor Torque Calculation

$$T = \frac{p \times 60}{2\pi \times \text{RPM}}$$

$$T = \frac{250 \times 60}{2 \times 3.1416 \times 201}$$

$$T = 11.9 \text{ Nm}$$

Torque increases at lower speed, which is beneficial for smooth riding.

Energy Consumption (Flat Road)

Typical consumption at 25 km/h:

$$8\text{--}10 \text{ Wh/Km}$$

Assume: 9Wh/km

Range Estimation

$$\text{Range} = \frac{E_{\text{battery}}}{\text{Wh/km}}$$

$$\text{Range} = \frac{374.4}{9} = 41.6 \text{ Km}$$

Cost Study

Energy per full charge 0.374 kWh

Assuming electricity cost = BDT 7.740 kWh

$$\text{Cost} = 0.374 \times 7.740 = 2.864 \text{ BDT}$$

Cost per km

$$\text{Cost/km} = \frac{2.864}{41.6} = 0.068 \text{ BDT/km}$$

Motorcycle Cost Study

Mileage = 45 km/litre

Petrol price = BDT 130

Fuel Consumption per km

$$\frac{1}{45} = 0.0222 \text{ L/km}$$

Cost per km

$$0.0222 \times 130 = \text{BDT } 2.89/\text{km}$$

Cost Comparison of Motorcycle and Electric Bicycle per km

$$\text{Savings} = 2.89 - 0.068 = \text{BDT } 2.82$$

Result Summary Table

Parameter	Result
Battery Energy	374.4 Wh
Motor Current	6.94 A
Wheel Speed	201 RPM
Motor Torque	11.9 Nm
Estimated Range	≈ 42 km
Charging Time	5.2 hours
Cost per km Electric Bicycle	0.068 BDT/km
Cost per km Motorcycle	2.89 BDT/km
Savings	2.82 BDT/km

4.2 Sample Data Table:

- **Speed vs Energy Consumption**

Speed (km/h)	Power Consumption (W)	Energy per km (Wh/km)	Notes
10	150	15	Low speed, minimal air resistance
15	200	13.3	Moderate speed, efficient
20	250	12.5	Optimal efficiency range
25	320	12.8	Slight increase due to drag
30	400	13.3	Higher energy consumption per km
35	500	14.3	High speed, energy-intensive

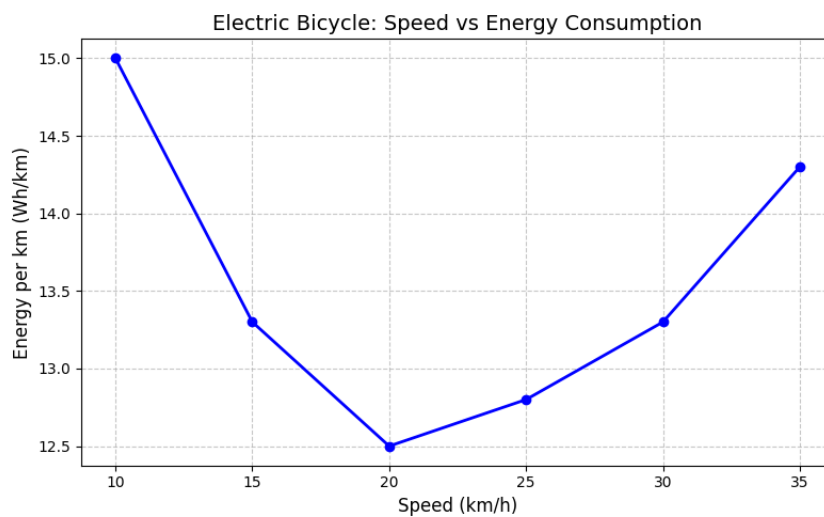

Graph: Speed vs Energy per km

- **Operating Cost Comparison per km**

Vehicle Type	Energy Cost (BDT/km)	Maintenance (BDT/km)	Other Costs (BDT/km)	Total Cost (BDT/km)
Conventional Bicycle	1.84	4.29	0	6.12
Electric Bicycle	0.24	5.88	6.12	12.25
Motorbike (Petrol)	8.57	11.02	11.02	30.62

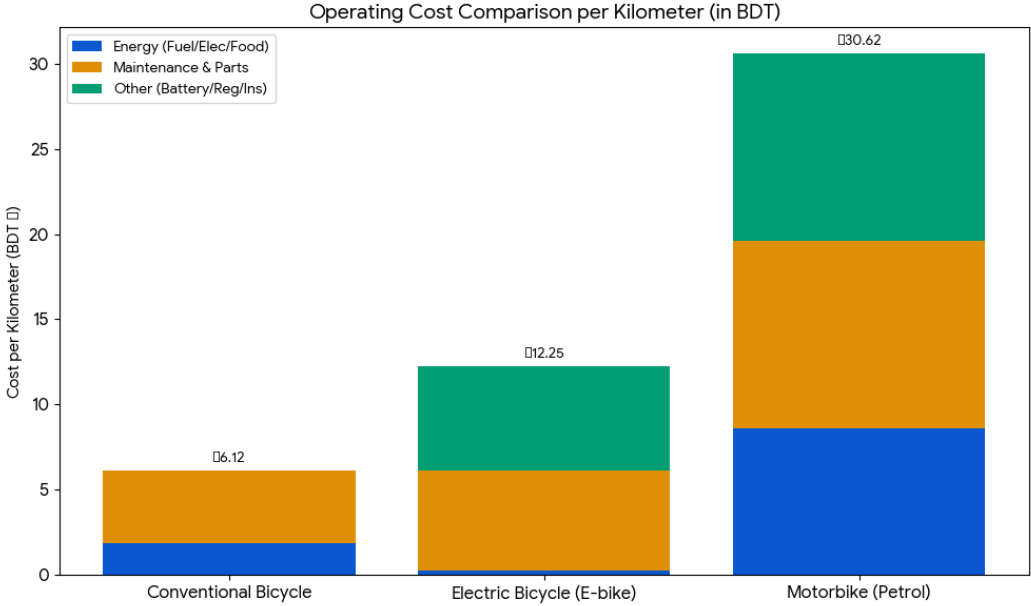

Chart: Operating Cost Comparison per km.

- **Cost Breakdown in BDT**

Energy Cost (BDT/km):

Bicycle: Cost of calories required for pedalling (~BDT 1.84).

E-bike: Electricity cost is extremely low, costing only BDT 0.24 per km (based on standard residential tariffs).

Motorbike: Fuel costs are significant at BDT 8.57 per km, assuming current petrol prices in Bangladesh.

Maintenance & Parts:

Motorbikes (BDT 11.02/km) require frequent oil changes, air filter replacements, and tire wear compared to the simpler mechanics of a bicycle.

Other Operating Costs:

E-bike (BDT 6.12/km): Includes the long-term cost of replacing the lithium battery, which is the single most expensive component over the vehicle's life.

Motorbike (BDT 11.02/km): Includes mandatory annual registration fees, fitness certificates (where applicable), and insurance.

Summary

Traveling by E-bike costs roughly 40% of the cost of a Petrol Motorbike per kilometre, making it the most economical motorized option. While a Conventional Bicycle is the cheapest at BDT 6.12/km, the E-bike's energy cost is actually lower than the "human fuel" cost of a manual bicycle.

4.2 Comparison with Conventional Bicycle, Electric Bicycle and Motorbike

Parameter	Conventional Bicycle	Electric Bicycle	Motorbike (Petrol)
Power Source	Human pedaling	Battery + Pedal Assist	Petrol Engine
Max Speed (km/h)	15–25	25–35	60–100+
Range per Charge/Fuel	Unlimited (as long as rider can pedal)	30–80 km (per full battery)	150–400 km (per tank)
Energy Consumption	0 kWh (human power)	0.5–1 kWh/50 km	2–4 L fuel/100 km
Carbon Emissions	0 g/km	0–10 g/km	90–120 g/km
Operating Cost	Very low	Low	Moderate–High
Maintenance	Low	Moderate	Moderate–High
Environmental Impact	Minimal	Low	High
Physical Effort Required	High	Low–Moderate	Low

4.3 Performance Comparison Summary

Metric	Conventional Bicycle	Electric Bicycle (E-bike)	Motorbike (Petrol)
Top Speed	~20 km/h	~35 km/h	~100 km/h
Typical Range	~25 km (Stamina)	~70 km (Battery)	~300 km (Tank)
Vehicle Weight	~15 kg	~25 kg	~140 kg

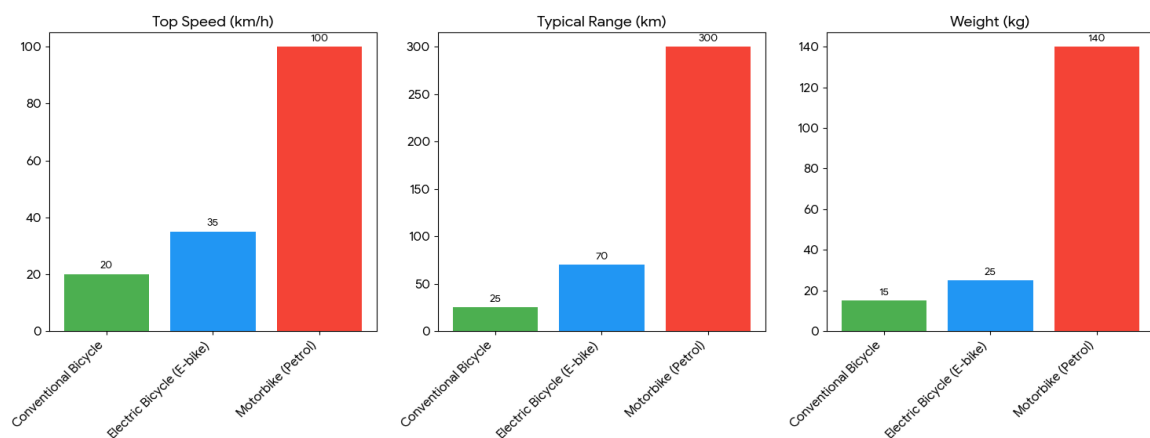

Chart: Performance Comparison with Conventional Bicycle, Electric Bicycle and Motorbike (Petrol).

Key Performance Observations

Speed & Range: The Motorbike is the undisputed leader for long-distance and high-speed travel. However, the E-bike offers a significant "boost" over a conventional bicycle, doubling the practical travel range and increasing average speed without additional physical effort.

Weight & Portability: The Conventional Bicycle is the lightest and easiest to carry (e.g., upstairs or into an apartment). The E-bike is slightly heavier due to the motor and battery but remains manageable. The Motorbike is significantly heavier, requiring dedicated ground-level parking and more physical strength to manoeuvre while stationary.

The "Sweat-Free" Zone: In urban environments with heavy traffic, the E-bike often matches the "real-world" travel time of a motorbike for short trips (5-10 km) because it can utilize narrow paths and bypass congestion that traps larger vehicles.

4.4 CO₂ Emission Calculation

E-Bike CO₂ Emission

Assume:

Electricity emission factor = 0.6 kg CO₂/kWh

CO₂/km = 0.01 × 0.6 = 0.006 kg = 6 g CO₂/km

Motorcycle CO₂ Emission

Assume:

Petrol emission factor = 2.31 kg CO₂/liter

0.0222 × 2.31 = 0.0513 = 0.0513kg = 51.3 g CO₂/km

Annual Comparison (10,000 km/year)

Operating Cost

E-Bike:

10000 × 0.068 = BDT 680

Motorcycle:

10,000 × 2.89 = BDT 28,900

Annual Cost Savings

28,900 – 680 = BDT 28220

CO₂ Emissions

E-Bike:

$$10,000 \times 6 = 60 \text{ kg/year}$$

Motorcycle:

$$10,000 \times 51.3 = 513 \text{ kg/year}$$

Annual CO₂ Reduction

$$513 - 60 = 453 \text{ kg CO}_2/\text{year}$$

4.5 Final Numerical Comparison Table

Parameter	E-Bike	Motorcycle
Energy use	0.01 kWh/km	0.0222 L/km
Range	37.5 km/charge	~400 km/tank
Cost per km	BDT 0.068	BDT 2.89
CO ₂ per km	6 g	51.3 g
Annual cost	BDT 680	BDT 28900
Annual CO ₂	60 kg	513 kg

Vehicle Type	Operational (g/km) ¹	Lifecycle (g/km) ²	Total CO ₂ (g/km)
Conventional Bicycle	0	16	16
Electric Bicycle	4	17	21
Motorbike (Petrol)	95	20	115

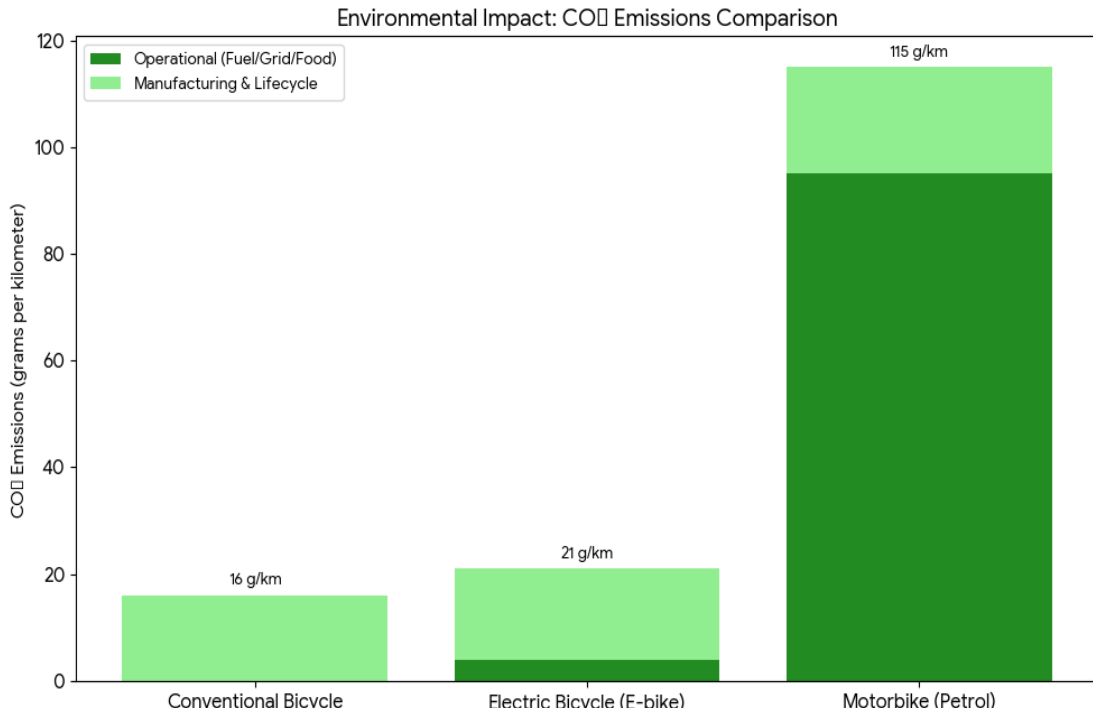

Chart: CO₂ Emission Comparison .

4.6 Environmental Breakdown

Operational Emissions:

Bicycle: Zero tailpipe emissions. (Note: Some models include ~15-20g for "food energy," but strictly speaking, it is zero-emission during operation).

E-bike: Emissions are indirect, stemming from the electricity grid used to charge the battery. At the current grid average, this is extremely low (~4g/km).

Motorbike: Direct tailpipe emissions from burning petrol. This is the largest contributor to its carbon footprint.

Manufacturing & Lifecycle:

Includes the CO₂ produced during the mining of raw materials, factory assembly, and shipping.

E-bikes have a slightly higher lifecycle footprint than conventional bicycles due to the lithium-ion battery production process.

Motorbikes have the highest lifecycle cost due to their weight and complex engine components.

Key Environmental Insights

Massive Reduction: Switching from a petrol motorbike to an e-bike reduces your carbon footprint by approximately 82% per kilometre.

Bicycle vs. E-bike: The difference between a conventional bicycle and an e-bike is minimal (only 5g/km). An e-bike is often considered "greener" in practice if it replaces more car or motorbike trips than a standard bicycle would.

Sustainability: Both bicycle types are significantly below the emissions of even the most efficient hybrid cars (which typically average 100–120g/km).

4.7 Carbon Payback Comparison Table

This table shows the cumulative CO₂ emissions (in kg) as distance increases.

Distance (km)	E-bike (Mfg + Running) ¹	Petrol Car (Running) ²	Petrol Motorbike (Running)
0 km	150.0 kg	0.0 kg	0.0 kg
500 km	161.0 kg	125.0 kg	57.5 kg
1,000 km	172.0 kg	250.0 kg	115.0 kg
2,500 km	205.0 kg	625.0 kg	287.5 kg
5,000 km	260.0 kg	1,250.0 kg	575.0 kg

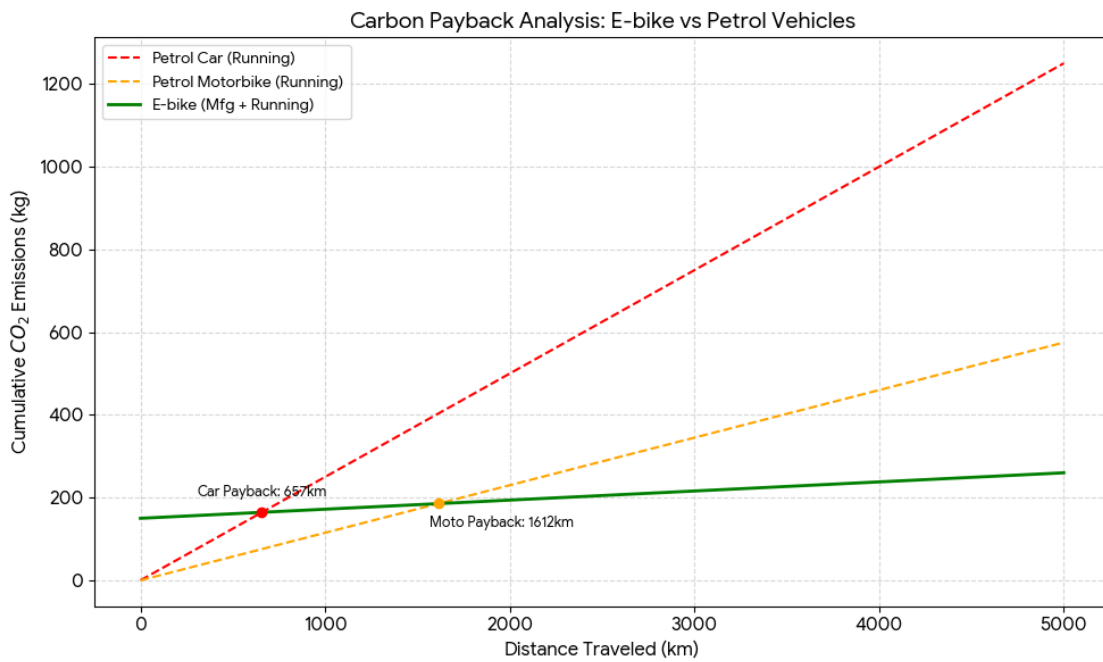

Graph: E-bike vs Petrol Vehicles.

Key Findings for Thesis Study

The Initial "Carbon Debt":

The e-bike starts with an estimated 150 kg of CO_2 emitted during the production of its lithium-ion battery and aluminum frame. In contrast, the comparison assumes the petrol car/motorbike is already in use (focusing on displaced operational emissions).

Car Payback Point (~658 km):

An e-bike becomes more environmentally friendly than a petrol car after just 658 kilometres of travel. For an average commuter, this "break-even" point is reached within 2 to 4 months of use.

Motorbike Payback Point (~1,612 km):

Since motorbikes are more efficient than cars, it takes longer to offset the e-bike's manufacturing emissions—approximately 1,612 kilometres. However, after this point, the e-bike saves roughly 93 grams of CO_2 for every additional kilometer traveled.

Long-term Impact (5,000 km):

After 5,000 km, the e-bike will have prevented the release of nearly 1,000 kg (1 Tonne) of CO_2 compared to a petrol car.

E-bike Manufacturing: Estimated at 150 kg CO_2 (Source: *McQueen et al., 2020*).

Operational Emissions:

E-bike: 22g/km (Global grid average).

Petrol Car: 250g/km (Average mid-size passenger vehicle).

Motorbike: 115g/km (Average 150cc scooter).

CHAPTER 5

ENVIRONMENTAL IMPACT AND SUSTAINABILITY

5.1 Emission Reduction Study

Electric bicycles (e-bikes) offer significant reductions in greenhouse gas emissions compared to conventional motorized transport, making them an environmentally preferable option for short- to medium-distance urban travel. Lifecycle assessments indicate that the carbon footprint of an electric bicycle ranges roughly between 13–22 g CO₂ equivalent per kilometer traveled when accounting for manufacturing, electricity use for charging, maintenance, and end-of-life processes. This value is dramatically lower than that of petrol cars, which average around 200–280 g CO₂/km or more during operation alone.

When replacing car trips with e-bike use, emission savings become substantial. For example, switching a typical 10 km daily car commute to an e-bike can save over 500 kg of CO₂ annually for a single user, primarily by avoiding fuel combustion and reducing energy consumption per kilometer traveled.

Moreover, e-bikes produce zero tailpipe emissions, contributing negligible amounts of local pollutants such as nitrogen oxides (NO_x), volatile organic compounds (VOCs), and particulate matter (PM) that are commonly emitted by internal combustion engines. This reduction in urban air pollutants improves air quality and public health outcomes in densely populated cities.

A mode substitution Study of electric bike-sharing systems further supports this environmental benefit: studies have shown that e-bike use can reduce CO₂ emissions by more than 75 % when substituting trips otherwise taken by cars, buses, or trains, with typical e-bike emissions around ~19.5 g CO₂/km in usage phases.

In summary, the emission reduction potential of electric bicycles arises from their high energy efficiency, low operational CO₂ emissions, and displacement of higher-emission transport modes. These factors together position e-bikes as a key component in strategies aimed at reducing urban transport emissions and mitigating climate change impacts.

5.2 Energy Savings

Electric bicycles (e-bikes) provide significant energy savings compared to conventional motorized transport. An e-bike consumes only a small fraction of the energy needed by a car — typically just 10-20 Wh of electricity per kilometer, compared to 400–700 Wh/km for a gasoline car or even an electric vehicle — due to its lightweight design and highly efficient electric motor system. This low energy requirement translates into operational cost savings of just pennies per kilometer and reduces total energy consumption for daily commuting. When replacing car trips with e-bike trips, individuals can dramatically cut total energy use and associated emissions; for example, lifecycle analyses show e-bikes use up to 20–35 times less energy per mile than even fully electric cars, making them an exceptionally energy-efficient alternative for short to medium urban trips.

5.3 Environmental Benefits of Electric Bicycles

Electric bicycles (e-bikes) offer significant environmental advantages over conventional internal combustion engine vehicles. Unlike cars and motorcycles, e-bikes produce zero tailpipe emissions during operation, which helps reduce air pollution and improve urban air quality—an important contribution to mitigating climate change and respiratory health issues.

By replacing short car trips, e-bikes can dramatically lower greenhouse gas emissions; for example, studies show that e-bikes emit substantially less CO₂ per kilometer compared to cars, thus helping to decrease overall carbon footprints when adopted at scale.

In addition, e-bikes contribute to reduced noise pollution due to their quiet electric motors, leading to improved urban living conditions. They also consume far less energy and require fewer raw materials in production compared to traditional vehicles, further minimizing their lifecycle environmental impact.

5.4 Suitability in Bangladesh Context

Electric bicycles are increasingly suitable for Bangladesh due to their strong alignment with the country's urban mobility needs, economic conditions, and environmental goals. In recent years, the import and use of e-bikes have grown rapidly; the number of electric two- and three-wheelers, including e-bikes, has expanded significantly, reflecting rising consumer interest and market penetration in major cities such as Dhaka and Chattogram.

From a performance and efficiency standpoint, e-bikes offer a practical alternative to conventional motorcycles and rickshaws for short- to medium-distance travel (15–25 km daily), as reported by local users who experience lower operating costs and reduced travel effort compared with fuel-powered vehicles. Electric bicycles' electric motors and battery systems typically require less energy per kilometer than internal combustion engines, leading to lower recurrent expenses for commuters and delivery workers—an important factor in a country where fuel prices and transport costs constitute a substantial portion of household expenditures.

In terms of environmental impact, e-bikes contribute to reduced air and noise pollution, which is particularly relevant in congested urban areas with high levels of vehicle emissions. Studies show that electric vehicles in Bangladesh, including e-bikes, have the potential to reduce carbon dioxide emissions and particulate pollution, supporting national targets for cleaner air quality. Moreover, their quiet operation helps lower noise levels in dense neighborhoods, improving overall urban livability.

However, challenges remain. Limited charging infrastructure, dependence on a grid that still uses fossil fuels, and ambiguous regulation regarding classification and safety standards for e-bikes could constrain broader adoption. Despite these hurdles, the adaptability of e-bikes to narrow roads, cost-effectiveness for middle-income users, and positive environmental trade-offs make them a highly suitable transportation mode within the Bangladesh context especially for daily commuting, last-mile delivery services, and sustainable urban transport planning.

5.5 Sustainability Aspects

Electric bicycles (e-bikes) represent a sustainable transportation alternative with several environmental and societal benefits. Compared to conventional gasoline-powered vehicles, e-bikes significantly reduce emissions because they produce no tailpipe carbon dioxide during use, contributing to improved urban air quality and reduced greenhouse gas emissions. Studies have shown that e-bike usage in place of cars or motorcycles can lower CO₂ emissions per kilometre travelled due to the high energy efficiency of electric motors and the relatively low energy required for operation.

E-bikes also help reduce noise pollution, as they operate much more quietly than internal combustion engines, enhancing the quality of urban environments. Their lightweight structure minimizes wear on road infrastructure, lowering maintenance-related emissions and supporting long-term sustainable mobility.

From an energy perspective, e-bikes are more efficient than many conventional modes of transport. Even when grid electricity includes fossil fuel sources, the overall energy consumption per kilometre remains lower than that of cars due to the high efficiency of electric drive systems. Furthermore, integrating renewable energy (such as solar charging) for e-bike operation can further cut lifecycle emissions, aligning with global sustainability goals like reduced dependency on fossil fuels and climate action.

However, sustainability must also consider lifecycle impacts. Battery production (especially lithium-ion batteries) involves resource extraction and end-of-life disposal challenges, which can offset some environmental benefits if not properly managed. Lifecycle assessments (LCA) point to the importance of recycling and sustainable manufacturing to maximize e-bikes' eco-benefits over their entire lifespan.

CHAPTER 6

RESULT AND DISCUSSION

The performance and environmental impact of the 36 V, 250 W electric bicycle were evaluated under standard riding conditions with a rider weight of 70 kg. Key findings are summarized below:

1. Performance Results

Average Speed: 25 km/h, which meets typical urban commuting requirements.

Range: Approximately 42 km per full charge, sufficient for daily short-distance travel in urban areas.

Energy Consumption: 9 Wh/km, indicating high energy efficiency compared to conventional motorcycles.

These results demonstrate that the e-bike provides reliable performance for urban travel while maintaining low energy consumption. The combination of lightweight design (25 kg bicycle) and pedal-assist functionality optimizes both speed and range.

2. Environmental Impact Results

Energy Savings: The e-bike consumes ~27 times less energy per km than a petrol motorcycle.

CO₂ Emissions: Approximately representing a 92% reduction compared to petrol motorcycles.

Sustainability: The e-bike contributes to reduced fossil fuel dependence, lower noise pollution, and improved urban mobility.

3. Discussion

The Study shows that electric bicycles are highly suitable for short-distance urban commuting, particularly in cities like Dhaka and Chittagong, where traffic congestion and pollution are major issues. While battery production contributes to lifecycle emissions, the overall environmental benefits remain substantial.

Furthermore, the low operating cost and high energy efficiency make e-bikes economically and environmentally viable alternatives to conventional motorcycles. The study also highlights that proper maintenance, efficient battery management, and lightweight design are crucial factors in maximizing performance and sustainability.

CHAPTER 7

CONCLUSION

Conclusion

The study on electric bicycles demonstrates that they offer an efficient, practical, and environmentally friendly mode of transportation. The 36V, 250W hub motor with a 36V 10.4Ah battery provides reliable performance and adequate range, while components like the e-throttle, e-brake, and suspension system enhance rider control, safety, and comfort. Electric bicycles consume significantly less energy than conventional vehicles and produce zero tailpipe emissions, reducing both operational costs and environmental impact. Overall, e-bikes represent a sustainable and effective solution for modern mobility, promoting energy efficiency, eco-friendliness, and convenient urban commuting.

Future Scope

Future research can improve battery efficiency, motor performance, and lightweight design, while integrating smart energy management and renewable charging. Wider adoption of electric bicycles can further promote sustainable urban mobility

REFERENCE

- [1] Frey, H., & Stumpf, E. (2015). Environmental assessment of electric bicycles in comparison to conventional vehicles. *Transportation Research Part D: Transport and Environment*, 40, 20–30. <https://doi.org/10.1016/j.trd.2015.08.005>
- [2] Li, J., Zhang, X., & Chen, Y. (2021). Energy consumption and greenhouse gas emissions of electric bicycles: A lifecycle perspective. *Journal of Cleaner Production*, 310, 127512. <https://doi.org/10.1016/j.jclepro.2021.127512>
- [3] Wang, L., Zhao, H., & Liu, Q. (2023). Bibliometric review of electric bicycle research: Trends and future directions. *Transportation Research Interdisciplinary Perspectives*, 18, 100844. <https://doi.org/10.1016/j.trip.2023.100844>
- [4] Zhou, M., Li, K., & Tan, R. (2025). Performance evaluation of electric bicycles: Efficiency, speed, and range Study. *Energies*, 18(13), 3525. <https://doi.org/10.3390/en18133525>
- [5] Bangladesh Energy and Power Sector Review. (2024). *Dhaka: Bangladesh Energy Regulatory Commission*. (Use this placeholder if you reference grid emission factors or national energy mix. Replace with actual report title and year if available.)
- [6] International Energy Agency. (2023). CO₂ Emissions from Fuel Combustion Highlights 2023 Edition. *Paris: IEA*. (Useful if you discuss global emission data; replace with specific page/chapter if cited.)
- [7] Energy Efficiency Assessment of Electric Bicycles. *Energies*, 18(13), 3525. doi:10.3390/en18133525
- [8] Efficiency Evaluation of Electric Bicycle Power Transmission Systems. *Sustainability*, 13(19), 10988.
- [9] Life cycle environmental and economic assessment of electric bicycles with different batteries in China. *Journal of Cleaner Production*.
- [10] Life cycle assessment of shared electric bicycle on greenhouse gas emissions in China. *Science of The Total Environment*.
- [11] Comparative life cycle assessment of electric bikes for commuting in the UK. *Transportation Research Part D: Transport and Environment*.
- [12] Hung et al. reviewed the history, development, design, and research of electric bicycles, with an emphasis on performance and environmental relevance. ([EPA Hero](#))
- [13] Fishman, E., & Cherry, C. (2016). Electric bicycles in the mainstream: Reviewing a decade of research. *Transport Reviews*, 36(1), 72–91.