



SOLAR - DRIVEN SEAWATER DESALINATION SYSTEM

A Thesis by

Md Asaduzzaman	ME2201026297
Shakil	ME2202027210
Sajedul Islam	ME2202027035
Naeem Sikder	ME2202027216
Mohammad Mohtasim Billah	ME2202027086

Supervisor

Nuruzzaman Rakib
Assistant Professor
Department of Mechanical Engineering
Sonargaon University (SU)
Dhaka-1215, Bangladesh

JANUARY 2026

DECLARATION

It is declared hereby that this thesis paper or any part of it has not been submitted to anywhere else for the award of any degree.

Name : Md Asaduzzaman
ID: ME2201026297

Name: Shakil
ID: ME2202027210

Name: Sajedul Islam
ID: ME2202027035

Name: Naeem Sikder
ID: ME2202027216

Name: Mohammad Mohtasim Billah
ID: ME2202027086

Under Supervision of

Nuruzzaman Rakib
Assistant Professor
Department of ME
Sonargaon University (SU)

CERTIFICATION

This is to certify that this project entitled “**Solar - Driven Seawater Desalination System**” is done by the following students under my direct supervision. This project work has been carried out by them in the laboratories of the Department of Mechanical Engineering under the Faculty of Engineering, Sonargaon University (SU) in partial fulfillment of the requirements for the degree of Bachelor of Science in Mechanical Engineering.

Supervisor

Nuruzzaman Rakib
Assistant Professor
Department of ME
Sonargaon University (SU)

ACKNOWLEDGEMENT

The report titled as “**Solar - Driven Seawater Desalination System**” has been prepared to fulfill the requirement of our practicum program. In the process of doing and preparing our practicum report, we would like to pay our gratitude to some persons for their enormous help and vast cooperation.

At first, we would like to show our gratitude to the University authority to permit us to do our practicum. Specially, we would like to thank to our honorable Nuruzzaman Rakib, Assistant Professor, Department of Mechanical Engineering, SU – Sonargaon University Dhaka, for his valuable and patient advice, sympathetic assistance, cooperation, contribution of new ideas. Deep theoretical and hardware knowledge & keen interest of our supervisor in this field influenced us to carry out this project. His endless patience, scholarly guidance, continual encouragement, constant and energetic supervision, constructive criticism, valuable advice, reading many inferior drafts and correcting them at all stages have made it possible to complete this project.

The author are also grateful to Md. Mostofa Hossain. Associate Professor, Head of the Department of Mechanical Engineering and all respect teachers of the Mechanical Engineering Department for their co-operation and significant help for completing the thesis work successfully.

We are, indeed, grateful to all those from whom we got sincere cooperation and help for the preparation of this report.

ABSTRACT

This project presents the design and development of a Seawater Desalination Machine aimed at producing safe and usable fresh water from saline seawater. Due to the increasing scarcity of potable water, especially in coastal and remote regions, desalination has become a practical and necessary solution. The proposed system mainly operates on Reverse Osmosis (RO) technology, where seawater is forced through a semi-permeable membrane under controlled pressure. This process effectively removes dissolved salts, suspended particles, microorganisms, and other harmful contaminants from the water.

The machine consists of a pre-filtration unit, high-pressure pump, RO membrane, storage tank, and necessary piping and control components. Pre-filters help protect the membrane by removing larger impurities, while the RO membrane ensures high-quality desalinated water. The compact and modular structure of the system makes it easy to install, transport, and maintain.

This desalination machine is suitable for small-scale applications such as households, coastal communities, boats, laboratories, and emergency water supply systems. The project highlights a cost-effective and reliable approach to addressing water shortages. In the future, the system can be integrated with renewable energy sources like solar power to improve sustainability and reduce operational costs, making it an environmentally friendly solution to global water challenges.

TABLE OF CONTENTS

Declaration	ii
Certificate	iii
Acknowledgement.....	iv
Abstract	v
List of Figures	viii
List of Table	ix

CHAPTER

1. Introduction	1
1.1 Introduction.....	1
1.2 Problem Statement	3
1.3 Objectives	3
1.4 Work Flow Diagram	4
1.5 Methodology	5
1.6 Research Outline.....	5
2. Literature Review	6
2.1 Introduction.....	6
2.2 Literature Review	6
2.3 Summary	9
3. System Architecture	10
3.1 Introduction.....	10
3.2 Principle of Desalination	10
3.3 Proposed System Design	11
3.4 Block Diagram	14
3.5 Circuit Diagram	15
3.6 Working Principle.....	15
3.7 Cost Analysis	16

4. Hardware and Software Analysis	17
4.1 Introduction.....	17
4.2 Hardware & Software	17
4.3 Water Purifier Filter.....	17
4.4 UV Light.....	19
4.5 Inverter.....	20
4.6 Solar panel	21
4.7 MPPT	23
4.8 Battery.....	25
4.9 Pump Motor	25
4.10 Easy EDA	26
5. Result Analysis.....	27
5.1 Project outcome	27
5.2 Complete Project Prototype	28
5.3 Project Result Analysis and Data Table	28
5.4 Solar panel and battery performance Table	31
5.5 Advantages.....	32
5.6 Application.....	32
5.7 Limitation.....	32
5.8 Discussion.....	33
6. Future Work and Conclusion.....	34
6.1 Conclusion	34
6.2 Future Scope of Work.....	34
References	35

LIST OF FIGURES

Figure

1.1 Work Flow Diagram	4
3.1 Working Process of Sea Water Desalination	10
3.2 Top View of our Project.....	11
3.3 Right Side View of our Project	12
3.4 Front Side View of our Project	12
3.5 Full View of our Project.....	13
3.6 Block Diagram of Water Purifier Process.....	14
3.7 Block Diagram of Power Distribution	14
3.8 Circuit Diagram of our project.....	15
4.1 Water Purifier Filter	18
4.2 Ultraviolet Light for Drinking Water	19
4.3 Inverter	20
4.4 Solar Panel.....	21
4.5 Solar Panel Schematic Diagram.....	22
4.6 Solar Cell System Curve	22
4.7 Solar Charge Controller Circuit	23
4.8 MPPT Solar charge Controller.....	24
4.9 12V Battery	24
4.10 Pump Motor	25
4.11 Easy EDA Software Interface	26
5.1 Final View of Project	28
5.2 Litmus paper	30
5.3 TDS Meter	30

LIST OF TABLES

Table

01 List of Component with Price	16
02 Wasa Water Before Analysis Table	28
03 Wasa Water After Analysis Table	28
04 Sea Water Before Analysis Table	29
05 Sea Water After Analysis Table	29
06 Solar panel and battery performance Table	31

CHAPTER 1

INTRODUCTION

1.1 Introduction

In the modern world, water is essential for preserving a healthy environment, with the sea providing about 97% of the Earth's water. Surface and subsurface water are the two types of natural water sources. Most of the world's fresh water supply is found in surface water, such as lakes and rivers. However, recent below-average rainfall has severely reduced this water supply. The scarcity of or progressive decline in the annual worldwide rainfall has also caused subsurface water sources, which are meant to be more dependable, to fail. Globally there are an estimated one billion people who lack access to potable water, which has led to more than five million water-borne disease fatalities annually—four million of these being children.

Population growth and rising water demands have made the availability of water a major issue. Although freshwater is thought to be widely available, it is difficult to access in its unlimited cradle. There is a severe shortage of potable water in several nations across the world. However, seawater must undergo extensive processing before it can be consumed by humans. Khawaji, et al. estimated that desalinating brackish water and seawater could provide access to drinkable water for over 75 million people worldwide. According to Inventory, at the end of 2002, there were 17,348 seawater and brackish water desalination plants worldwide, generating 37.8 million cubic meters of drinking water daily. According to Assad, et al. the World Health Organization (WHO) reported that 25% of people on Earth reside in areas without access to potable water because these areas lack the basic infrastructure required to extract and purify water from subterranean natural reservoirs and watercourses.

Today, the world is plagued by widespread water scarcity, with Africa and the Arab world being the most afflicted. Although 6.3% of the world's population lives in these places, only 1.4% of the globe's freshwater resources are renewable. Desalination techniques for seawater and brackish water need to deal with the persistent issue of the growing need for potable water and limited availability. Karagiannis and Soldatos predict that by 2025, if water demand is not reduced or substitute/additional water sources are not significantly established, over 67% of

the world's population—including those in both developed and developing nations—may be at risk of a water shortage.

This paper identifies available technologies to address the global water scarcity problems with specific focus on optimizing a renewable energy-powered seawater reverse osmosis system for zero waste. The operational conditions and variable parameters of an effective full-sized seawater reverse osmosis (RO) desalination system can be challenging to model because they vary constantly due to seasonal variations and progressive membrane fouling over long-term filtration. Similarly, investors and consulting engineers must carefully assess the design of the RO plant, as well as the estimated capital and operational costs for large projects. These factors play a significant role in the pre-construction planning and evaluation processes and by thoroughly analyzing these factors, stakeholders can be able to make informed decisions and ensure the success of such projects. Brine waste or concentrate from the desalination process, which mainly contains organic matter, metals, surfactants and toxic substances, is another key problem that impacts the RO system's rate of recovery, thereby causing an increase in cost per unit of potable water production. The concentrate is typically rich in colour, chemical oxygen demand (COD), total dissolved solids (TDS), and salinity. Brine concentrate management requires a well-operated, low-cost technology to moderate the environmental impact of the brine discharge on the community.

Significant economic advantages can be achieved from the brine concentrate through innovative processing technology to recover the constituent salts for commercial purposes. Seawater's desalination treatment process is usually characterised by the generation of highly contaminated rejected brine streams. This rejected brine concentrate requires well-operated, low-cost technology to reduce the environmental impact for safe disposal. Significant economic improvements can be realized by recovering high purity industrial grade salt, bromine, boron, potassium, lithium, rubidium, calcium sulphate and magnesium from brine concentrate.

1.2 Problem Statement

The increasing scarcity of fresh drinking water has become a serious global challenge, particularly in coastal and arid regions where seawater is abundant but potable water is limited. Rapid population growth, climate change, irregular rainfall patterns, and overexploitation of surface and groundwater resources have significantly reduced the availability of safe drinking water. Existing freshwater sources are often insufficient to meet daily domestic, industrial, and agricultural demands. Although desalination technologies are available, many existing systems are expensive, energy-intensive, and difficult to maintain, especially in developing and remote areas. In addition, improper handling of brine waste from desalination plants causes environmental pollution and increases operational costs. Small-scale and affordable desalination solutions with efficient water recovery and minimal environmental impact are still limited. Therefore, there is a critical need to develop a compact, cost-effective, and efficient seawater desalination machine that can reliably produce potable water while minimizing energy consumption and environmental effects, making clean water accessible to communities facing severe water shortages.

1.3 Objectives

The objectives of this project:

- To design and develop a compact seawater desalination machine capable of producing safe and potable drinking water.
- To remove dissolved salts, impurities, and harmful microorganisms from seawater using effective filtration and RO technology.
- To address freshwater scarcity problems in coastal, remote, and water-stressed regions.
- To ensure the system is cost-effective, energy-efficient, and suitable for small-scale applications.
- To minimize environmental impact by reducing waste and improving water recovery efficiency.
- To develop a system that is easy to operate, maintain, and transport.
- To explore future integration with renewable energy sources such as solar power for sustainable operation.

1.4 Work Flow Diagram

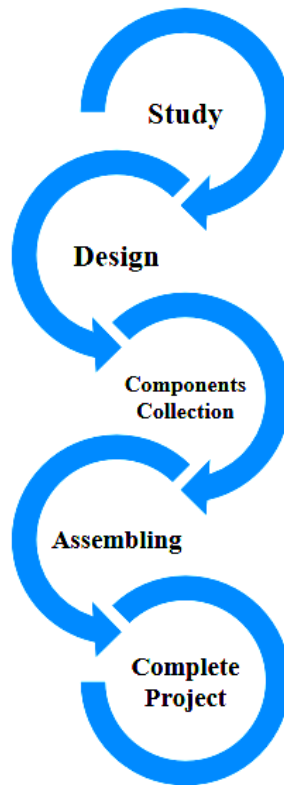

Figure 1.1 : Work Flow Diagram

This project follows a systematic development approach to design and implement a Seawater Desalination Machine. The process begins with the study phase, where existing water scarcity issues, desalination technologies, and system requirements are analyzed. Based on this understanding, the design stage focuses on planning the system layout, selecting suitable desalination methods, and ensuring efficiency and safety. Next, during components collection, essential parts such as filters, RO membrane, pump, storage tank, and power supply are carefully selected to meet performance needs. The assembling stage involves integrating all components into a compact and functional unit, ensuring proper connections and operation. Finally, the complete project phase includes testing and performance evaluation to verify water quality and system reliability. This step-by-step approach ensures a well-structured, efficient, and practical desalination solution to address freshwater scarcity.

1.5 Methodology

Our methodologies for the project:

- Study and analyze seawater desalination techniques and design a solar-powered RO system.
- Select and assemble components including solar panel, MPPT, battery, inverter, pump motor, filters, RO membrane, and UV light.
- Integrate the system to operate the DC pump directly and the filtration unit via inverter, ensuring proper water purification.
- Test and evaluate the system for water quality, efficiency, and performance under real operating conditions.

1.6 Research Outline

This project book consists of Six chapter. The first chapter contains the statement of the introduction, Problem Statement, work Flow Diagram, objectives of the study and Methodology. Chapter two contains system Literature Review details. Chapter three Discussed in Principle in Desalination, Proposed System Design, Block Diagram, Circuit Diagram, Working principle and Cost analysis.Chapter Four describes the hardware implementation with component details and the software which we have used for our work. Chapter Five deals with the result Analysis, Project outcome, shows the complete prototype, Advantage, Application and Limitation of the project that we have built. In the final chapter, we have discussed the , Future Scope, conclusion of the project.

CHAPTER 2

LITERATURE REVIEW

2.1 Introduction

In this chapter we discuss our system overview. In this paper they also work about **Solar - Driven Seawater Desalination System**. In below section we will describe some previous literature review. From previous literature we gather more knowledge to build this project and we successfully made it .

2.2 Literature Review

Gowtham M., et al. (2012): In this research work, the performance of solar concentrated distiller with latent heat storage capacity is compared with solar concentrated distiller with trays on the basin. Paraffin wax is used as the latent heat storage material. Experiments are conducted for improving productivity and this is done by various factors like heat storage capacity, exposure area and maintaining low depth [1].

Ozuomba J.O. et al. (2012): In this paper find a roof-type solar water distillation (RSWD) kit was fabricated and tested under actual environmental conditions of Ursula, an ancient town in the Eastern part of Nigeria. The system includes four major components; a rectangular wooden basin, an absorber surface, a glass roof and a condensate channel. The RSWD was able to generate 2.3m³ of distilled water within six days. Though the condensate was not large enough compared to human need as is peculiar to many solar stills, the efficiency can be enhanced [2].

Caroline S.E. Sardella (2012): We analyze in this paper the production rate of distillate water is estimated to be between 100 and 590 l/d per barked depending on the efficiency of the system. The water extracted from the drinking water tank is expected to be within the bacteriological and mineralogical advised quantities where no adverse health effects are observed. The distillate is expected to be partially remineralized during the mixing process with the harvested rain water. However, accurate monitoring and analysis of the water quality is advised during the pilot project [3] .

Prof. Alpesh Mehta et al. (2011): In this paper we observed that the increase in temperature and hence the evaporation is maximum in the period of 11:15 am to 1:30 pm. The maximum temperature achieved is 53 °C which is at 1:30 pm. then the temperature decreases. This experiment was to get pure water from the brackish water available. The brackish water we have supplied was 14litres and at the end of the experiment we got 1.5litres. The experiment was carried out in winter season. The TDS level of purified water obtained is 81 PPM. So the water obtained is potable. Theoretically, the experiment should fetch out 2.33litres. So the efficiency of the system is 6% [4].

Aayush Kaushal et al. (2010): According to this there are many methods for desalination of brackish water in to potable water. Therefore, different types of solar stills are discussed to produce pure water. A proper combination of cooling film parameters enhanced the still efficiency by 20%. In multi-effect diffusion model the productivity decreases about 15% with an increase in diffusion gaps between partitions from 5 mm to 10 mm. So for specific requirement there is a requirement to select solar still very Continuously based upon the local condition and operating conditions [5].

Phalak, M. Kurkure, P. Bhangale, N. Deshmukh, V. Patil (2017): He studied the manufacturing a low-cost ceramic water filter and filter system for the elimination of common pathogenic bacteria and suspended solids. A micro porous ceramic water filter in which clay was mixed with rice husk in a ration 2:1 by weight and a cylindrical shaped filter was manufactured by tradition oven drying and then burning in kiln at specified sintering temperature after being coated with silver nitrate solution for preventing the bacterial growth [6].

M. Z. H. Khan, M. R. Al-Mamun, S. C. Majumder, and M. Kamruzzaman (2015): They studied the removal of iron from water using the ash produced from banana residue. Ashes from different materials i.e., dry banana leaf, pseudo stem, rind, bamboo, rice husk were produced by controlled combustion. The mechanism of removal includes oxidation of iron at high pH or alkaline medium produced by potassium present in banana due to subsequent formation of potassium hydroxide. The study included analysis of chemical composition of banana ash and its efficiency in removal of iron from prefabricated water [7].

Hefei Zhang et al [8] present a hybrid solar desalination process of the multi-effect humidification dehumidification and the basin-type unit. The solar evacuated tube collector is employed in the desalination system, multi-effect humidification dehumidification desalination (HDD) process is calculated, and then the water excluded from the multi-effect HDD process is reused to desalinate in a basin-type unit further ahead. The research proves that the multi-effect HDD has much room to be enriched.

Guangping Cheng et al [9] proposed a solar desalination process using air humidification and dehumidification. In order to increase the output of freshwater, the doublepass solar air heater and tubular solar collector are used to heat the air and seawater respectively. The air is humidified by bubbling in the seawater pool, and dehumidified in the inorganic heat pipe condenser. The heat transfer performance of the solar air heater with double vacuum glass-covers and double air passes is studied, and the theoretical model of its heat transfer and the calculation methods are given.

M. Amidpour et al [10] experimentally evaluate and optimize the humidification–dehumidification desalination process for production of fresh water from brackish water. Experimental results show that two-stage HD desalination unit can increase thermal recovery in condensers and hence, reduce thermal energy consumption and investment cost of the unit. Productivity can also be increased by 20% compared with the singlestage unit.

M. Abd Elkader [11] experimented on a three stage multieffect humidification (MEH)-dehumidification process with energy storage system which was designed, manufactured, installed and outdoor tested in the Faculty of Engineering, Suez Canal University, Port Said, Egypt. The thermal collection part of the system (three flat plate collectors) has been designed to provide hot water to the desalination chambers. The investigational test results showed that, the increase of seawater mass flow rate through the setup from 0.1 liters to 0.13 liters increases the efficiency of the system by 10 %. It can be seen from the results also, that the use of energy storage increases the output by 13.5%.

Julian Blanco et al [12] have analyzed about the AQUASOL Project whose objective is the development of a lesser expensive and more energy efficient seawater desalination technology based on Multi-Effect Distillation process with zero brine discharge. Specific proposed technological developments (new design of CPC collector and absorption heat pump,

hybridization with natural gas and recovering of salt) are expected to both increase the energy efficiency of the process and process economy. The expected result would be an improved MED technology with market potentials and suitable to be applied in the Mediterranean area and similar locations around the World.

The study of literature survey on portable seawater desalination machines powered by solar panels for hikers represents a multifaceted convergence of renewable energy technologies, advanced membrane processes, and rugged design principles that are essential for remote, off-grid water purification. Early works in the field focused on the development of solar stills, which, while simple in design and operation, typically provided low throughput and were highly dependent on environmental conditions; these studies laid the groundwork for understanding the interplay between solar thermal energy and evaporation–condensation cycles in desalination. Over the past two decades, researchers have increasingly turned their attention to membrane-based technologies, particularly reverse osmosis (RO) and membrane distillation (MD), as a means of achieving higher water recovery rates and improved efficiency in portable systems [13].

In the literature, a consensus has emerged that for a machine to be effective in field conditions, it must integrate a robust solar energy harvesting system, an energy storage unit, and a compact, high-pressure pump capable of driving water through a desalination membrane under variable load conditions. Many studies have examined the performance characteristics of miniature high-pressure pumps, such as the Aquatec 6800 and 8800 Series, noting that their 12V or 24V DC operation aligns well with the voltage outputs of solar panels and battery systems, thereby enabling the development of lightweight, portable units that can be carried by hikers without significant burden. Researchers have also explored the use of advanced materials in membrane fabrication, including polymeric and composite membranes that exhibit high salt rejection rates while maintaining structural integrity under fluctuating pressures and temperatures encountered in outdoor environments [14].

2.3 Summary

From the literature discussed above, we gained a lot of knowledge and we inspired to do this project. We were able to do it with everyone tireless work.

CHAPTER 3

SYSTEM ARCHITECTURE

3.1 Introduction

The project objectives, methods, literature evaluation, and other details were all clarified in the preceding chapter. The block diagram, circuit diagram, Working principle, and final project instrument cost analysis will all be covered in this chapter.

3.2 Principle of Desalination

The Diagram the basic working principle of a seawater desalination system. In this process, ocean water is first collected and passed through a filter, which removes large particles, sand, and suspended impurities. After filtration, the water enters the desalination chamber, where energy—often from sunlight, electricity, or pressure—is applied. This energy helps separate salt and other dissolved minerals from the seawater.



Figure 3.1 : Working Process of Sea Water Desalination

Inside the desalination unit, clean water molecules are separated while salts and minerals are discharged as concentrated brine. The treated water then flows through an outlet pipe and is collected as fresh, potable water, suitable for drinking and daily use. Meanwhile, the removed salt and minerals are released or managed separately to reduce environmental impact.

3.3 Proposed System Design

The proposed 3D system design of the seawater desalination machine represents a compact, well-organized, and portable structure. All components are housed within a stainless-steel frame to ensure durability, corrosion resistance, and safety. The upper section accommodates the pre-filtration unit, while the reverse osmosis (RO) membrane and high-pressure pump are positioned centrally for efficient water flow. A pressurized storage tank is placed at the lower section to collect purified water. Proper piping, valves, and electrical wiring are arranged systematically to allow easy maintenance and smooth operation. The 3D design ensures optimal space utilization, stability, and reliable performance in coastal and remote environments.

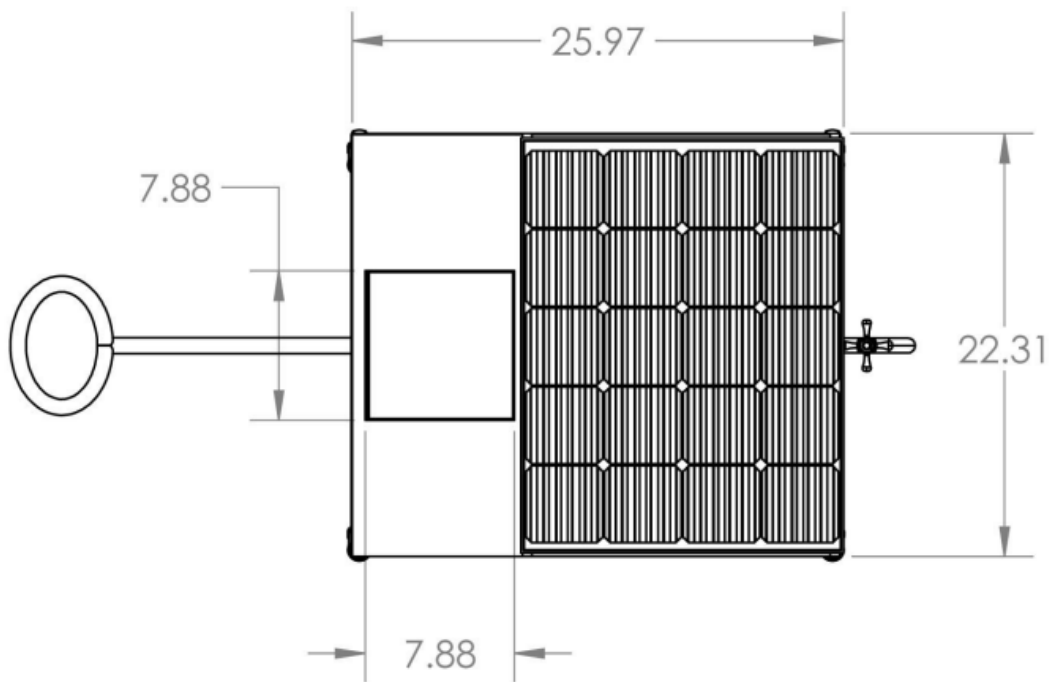

Figure 3.2 : Top View of our Project

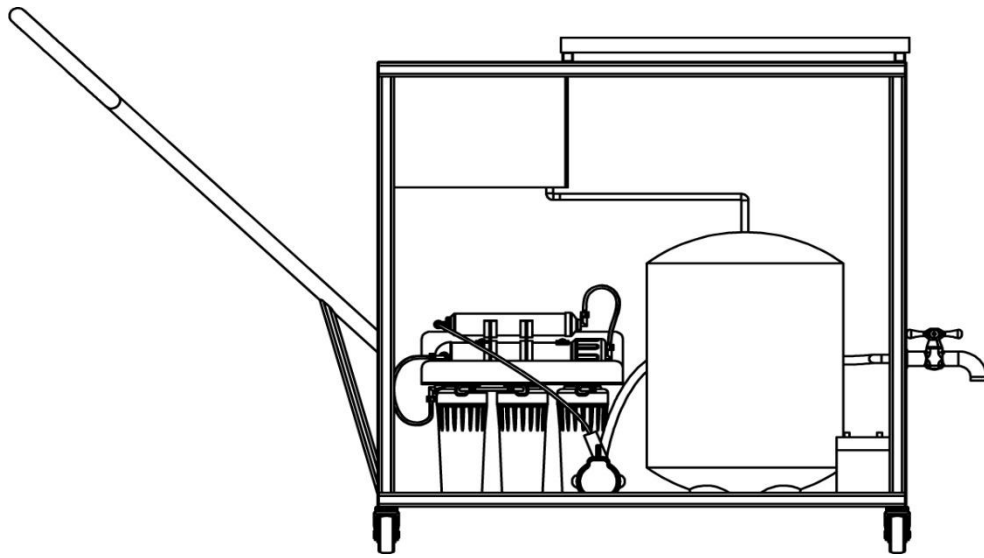

Figure 3.3: Right Side View of our Project

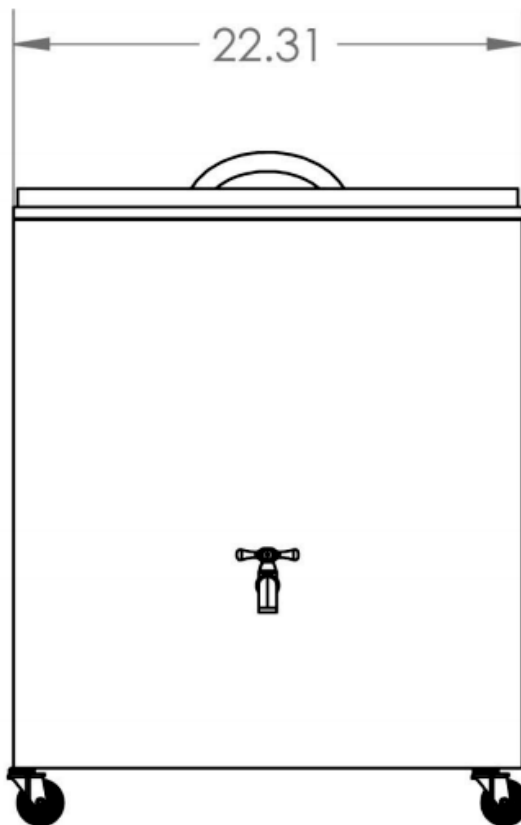

Figure 3.4: Front Side View of our Project

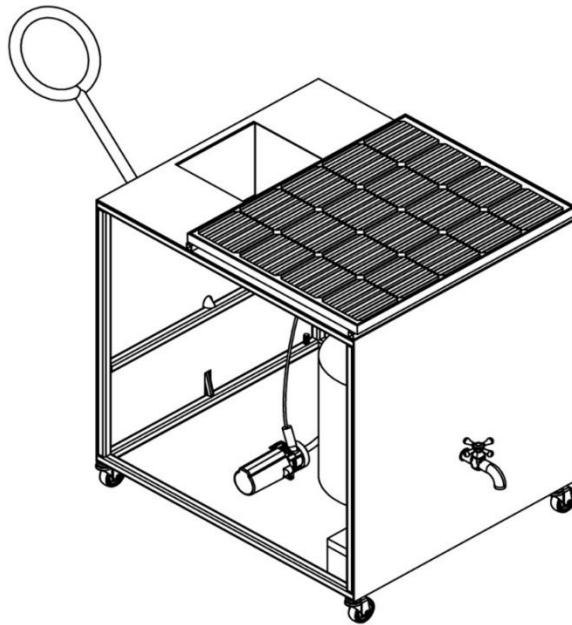

Figure 3.5: Full View of our Project

3.4 Block Diagram

Here is the block diagram of the **Solar - Driven Seawater Desalination System**, with all the essential components. All of the components are shown in below as a block in this diagram.

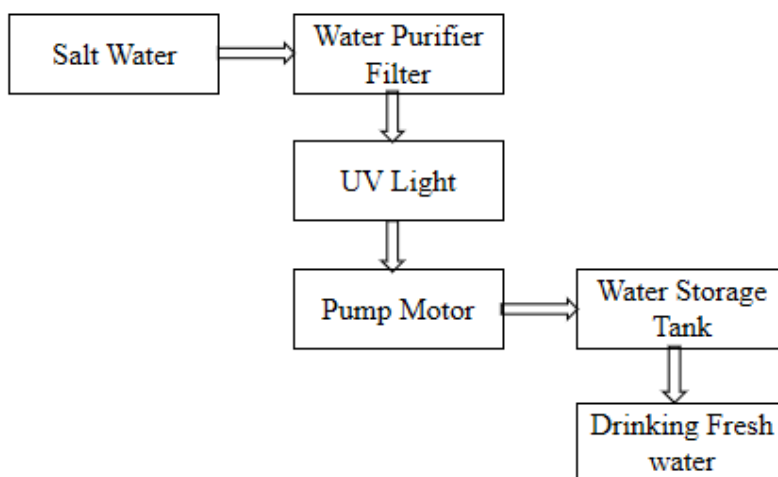

Figure 3.6: Block Diagram of Water Purifier Process

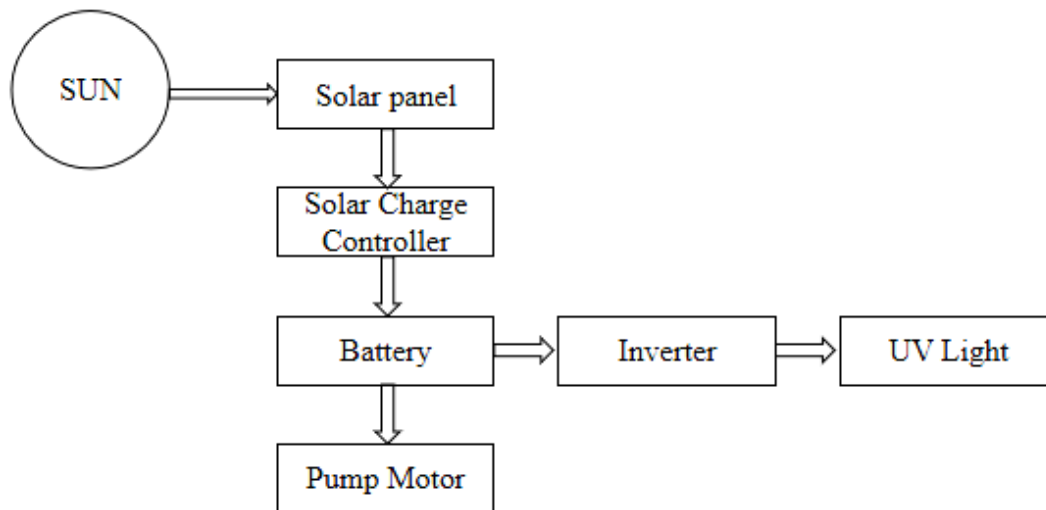

Figure 3.7: Block Diagram of Power Distribution

3.5 Circuit Diagram

In this part we show our project circuit design and connect our instrument through standard wire.

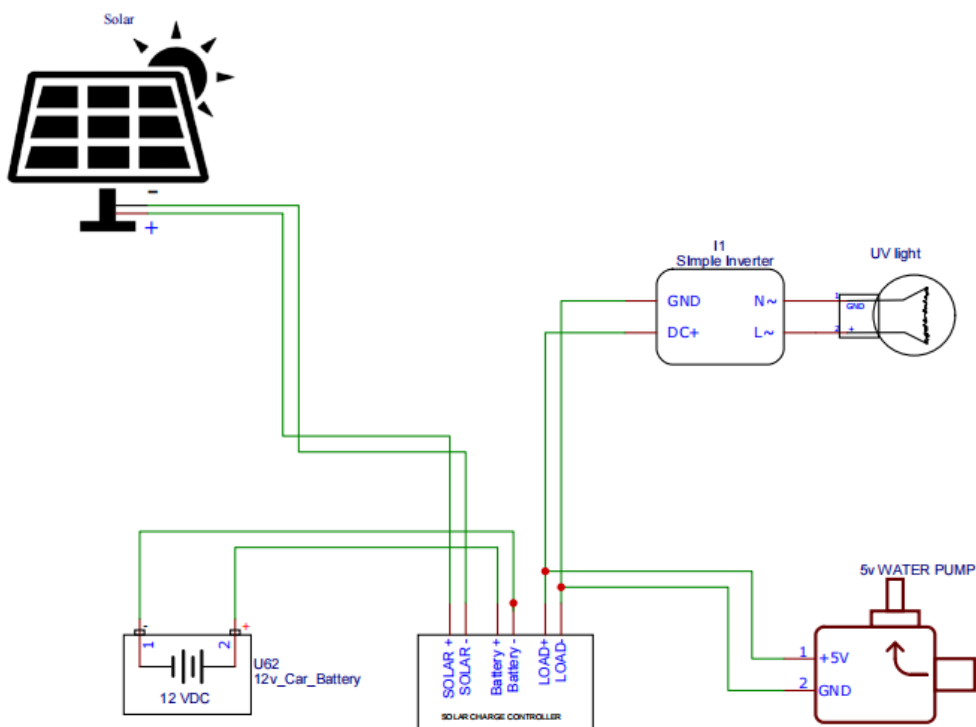

Figure 3.8: Circuit Diagram of Our Project

3.6 Working Principle

The Solar-Powered Seawater Desalination Machine uses renewable energy to convert seawater into potable water efficiently. Solar panels generate DC electricity from sunlight, which is managed by the MPPT (Maximum Power Point Tracking) charge controller to charge the battery efficiently. The stored DC power is used in two ways: directly powering the pump motor, which pressurizes seawater for filtration, and supplying the inverter, which converts DC into AC to operate the filter unit for pre-treatment.

Seawater first passes through the filter, removing sediments, suspended particles, and impurities. The pressurized water then enters the RO membrane, where dissolved salts, heavy metals, and microorganisms are separated. Finally, the purified water flows through a UV light unit for disinfection, ensuring it is safe for drinking. This system enables energy-efficient, eco-friendly desalination, providing reliable potable water in off-grid or coastal areas.

3.7 Cost Analysis

Table 1:List of Component with Price

Sl.no	Particulars	Specification	Qty.	Unit Price (Taka)	Total Price (Taka)
1	Filter		1	11000	11000
2	Solar panel	40 Watt / 12V	1	2200	2200
3	MPPT	Charge Controller	1	600	600
4	Inverter	DC to AC 500W	1	1200	1200
5	Pump Motor	DC 12V	1	700	700
6	UV Light		1	2500	2500
7	Battery	12 V	1	1500	1500
8	Body Frame			6000	6000
9	Others				2000
				Total	27,700/=

CHAPTER 4

HARDWARE AND SOFTWARE ANALYSIS

4.1 Introduction

In this section, we will discuss elaborately about “**Solar - Driven Seawater Desalination System**” and the component description, features, working procedure of our all equipment. The system hardware fabricates composed of micro-controller unit, power unit, source unit, power store unite, sensor unit and many more related components.

4.2 Hardware & Software

Hardware

- Filter
- UV Light
- Battery
- Solar Panel
- MPPT Solar Charge Controller
- Inverter
- Pump Motor

Software

- Easy EDA

4.3 Water Purifier Filter

A water purifier filter is a vital component used to improve water quality by removing physical, chemical, and biological contaminants. It works through different filtration stages such as sediment filtration, activated carbon filtration, RO (Reverse Osmosis), UF (Ultrafiltration), or UV treatment, depending on the purifier type. The sediment filter removes dust, sand, and rust particles, while the carbon filter eliminates chlorine, bad odor, and harmful organic compounds. RO membranes reduce dissolved salts, heavy metals, and microorganisms, making water safe for drinking. Some systems also include mineral cartridges to restore essential minerals for better taste and health.



Figure 4.1: Water Purifier Filter

Features

- A 5 stage filtration system along with reverse osmosis technology.
- Ensures 100% pure drinking water .
- The installation of accessories are included.
- Sterilised and 100% factory ready .
- Holds 150 litre water per day
- Under sink type of water purifier
- Ceramic faucet
- Operation pressure 15 – 85 PSI
- Feed water connector
- Filtration capacity is 75 GPD
- It's reserve capacity is 3.2G pressure tank
- 6mm of Food grade white colour PVC pipe
- Has an operating power of 220 volt

4.4 UV Light

UV Light (Ultraviolet Light) is a type of electromagnetic radiation with a wavelength shorter than visible light but longer than X-rays, typically in the range of 100–400 nanometers (nm). It is widely used for disinfection and sterilization because it can effectively destroy the DNA and RNA of microorganisms like bacteria, viruses, and protozoa, rendering them inactive and unable to reproduce. In water purification, UV lamps are installed inside purifiers to disinfect water without using chemicals, ensuring it is safe to drink while retaining its natural taste and minerals. UV light is also used in medical sterilization, air purification, and surface disinfection. While it is highly effective against pathogens, direct exposure to UV rays can be harmful to human skin and eyes, so proper shielding and safety precautions are necessary.



Figure 4.2: Ultraviolet Light for Drinking Water

Specification

- Water treatment machine Type: Water Purifier.
- Interface Diameter: DN20.
- Function: Direct Drink.
- Type: Conditioner.
- Water Yield (Liter/Minute): Flow rate: 1LPM = $1 * 60/1000 \text{ m}^3 / \text{hr}$ (about 3.8 liters / minute).
- Purifying Position: Terminal Purification.
- Power (W): 5-12W.
- Water Quality Requirements: Municipal Water/Well Water.
- Material: STAINLESS STEEL (304 stainless steel).
- POWER INPUT: 220v-50Hz.
- Interface Size Instruction: 4 Points = $1/2" = \text{DN } 15\text{mm} = \text{OD } 21.3\text{mm}$.

4.5 Inverter

An inverter is an electronic device that converts direct current (DC) into alternating current (AC), enabling the use of DC power sources like batteries or solar panels to run standard AC appliances. It is widely used in home power backup systems, solar energy setups, and industrial applications. Inverters come in different types, such as pure sine wave, modified sine wave, and square wave, each suitable for various loads and sensitive devices. They often include features like overload protection, short-circuit protection, and battery charging management. By providing continuous and stable AC power, inverters ensure that electronic devices operate efficiently during power outages or in off-grid situations. Modern inverters are also energy-efficient, portable, and compatible with renewable energy systems, making them essential for reliable electricity supply.



Figure 4.3: Inverter

Specification

- 500W DC12V to AC 220-240V Solar Power Inverter
- Continuous Output: 500W
- Peak Power: 1000W
- Input Voltage: DC12V
- Output Voltage: AC220-240V
- Wave Form: Modified Sine Wave
- Frequency: 50 ± 3 Hz
- Item Size: 16 * 9.5 * 5.5cm / 6.3 * 3.7 * 2.2in
- Item Weight: Approx. 380g / 13.4 Oz (500W)

4.6 Solar Panel

A solar panel is a set of solar photovoltaic modules electrically connected and mounted on a supporting structure. A photovoltaic module is a packaged, connected assembly of solar cells. The solar panel can be used as a component of a larger photovoltaic system to generate and supply electricity in commercial and residential applications. Each module is rated by its DC output power under standard test conditions (STC), and typically ranges from 100 to 320 watts. The efficiency of a module determines the area of a module given the same rated output - an 8% efficient 230 watt module will have twice the area of a 16% efficient 230 watt module. A single solar module can produce only a limited amount of power; most installations contain multiple modules. A photovoltaic system typically includes a panel or an array of solar modules, an inverter, and sometimes a battery and/or solar tracker and interconnection wiring.

Solar cell modules produce electricity only when the sun is shining. They do not store energy, therefore to ensure flow of electricity when the sun is not shining, it is necessary to store some of the energy produced. The most obvious solution is to use batteries, which chemically store electric energy. Batteries are groups of electro chemical cells (devices that convert chemical energy to electrical energy) connected in series.



Figure 4.4: Solar Panel

Battery cells are composed of two electrodes immersed in electrolyte solution which produce an electric current when a circuit is formed between them. The current is caused by reversible chemical reactions between the electrodes and the electrolyte within the cell. Batteries that are re-chargeable are called secondary or accumulator batteries. As the battery is being charged, electric energy is stored as chemical energy in the cells. When being discharged, the stored chemical energy is being removed from the battery and converted to electrical energy. In East-Africa, the most common type of secondary battery is the Lead-acid battery .

Solar Charger Controller

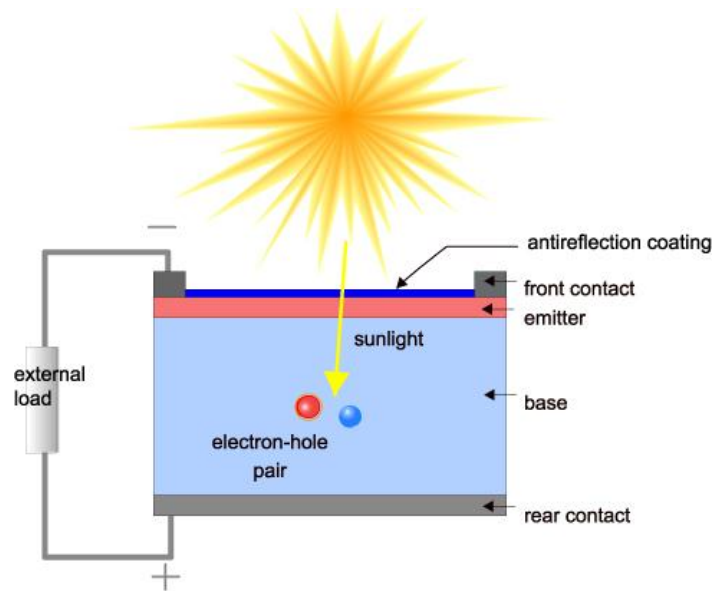

Figure 4.5: Solar Panel Schematic Diagram

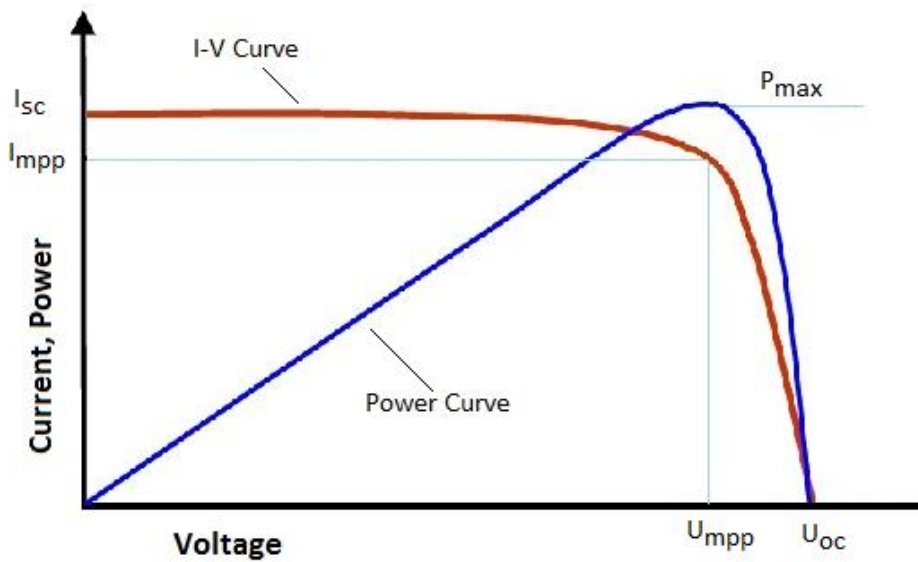

Figure 4.6: Solar cell System Curve

Here is a solar charger circuit that is used to charge Lead Acid or Ni-Cd batteries using the solar energy power. The circuit harvests solar energy to charge a 6 volt 4.5 Ah rechargeable battery for various applications. The charger has voltage and current regulation and over voltage cut-off facilities.

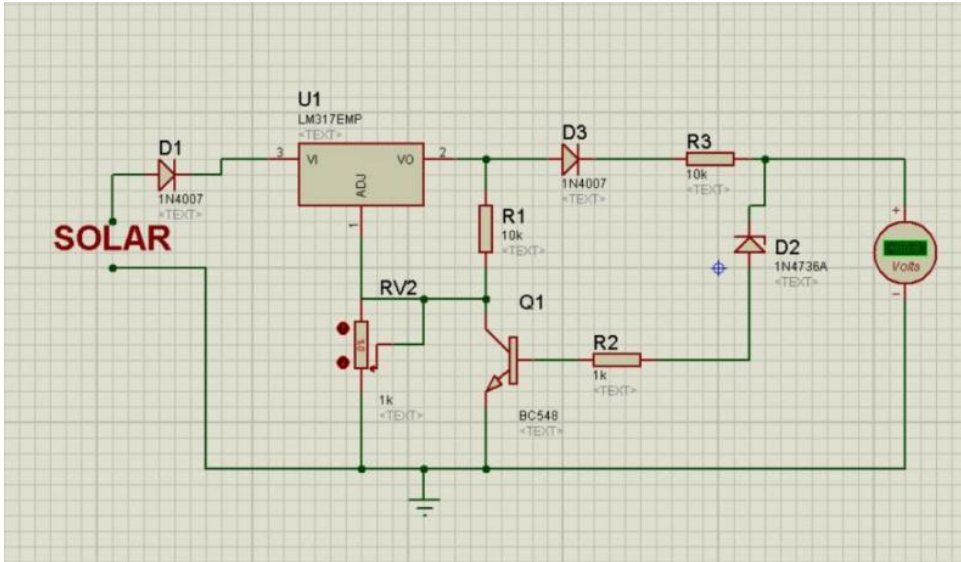

Figure 4.7: Solar Charger Controller Circuit

The circuit uses a 12 volt solar panel and a variable voltage regulator IC LM 317. The solar panel consists of solar cells each rated at 1.2 volts. 12 volt DC is available from the panel to charge the battery. Charging current passes through D1 to the voltage regulator IC LM 317. By adjusting its Adjust pin, output voltage and current can be regulated. VR is placed between the adjust pin and ground to provide an output voltage of 9 volts to the battery. Resistor R3 Restrict the charging current and diode D2 prevents discharge of current from the battery.

4.7 MPPT

An MPPT (Maximum Power Point Tracking) Solar Charge Controller optimizes the power output from solar panels by continuously adjusting the operating point to find the maximum power point. It ensures the solar panels operate at their most efficient voltage and current, maximizing energy harvest. MPPT technology converts excess voltage into additional current, improving system efficiency compared to traditional controllers. This results in faster battery charging, enhanced performance in low light or cloudy conditions, and overall better energy utilization. MPPT controllers are essential for maximizing the lifespan and effectiveness of solar power systems, especially in larger or more complex setups.



Figure 4.8: MPPT Solar Charge Controller

Specification

- **Input Voltage Range:** 12V, 24V, or 48V systems
- **Efficiency:** 95% or higher
- **Maximum Charging Current:** 10A to 100A, depending on the model
- **Operating Temperature:** -20°C to 60°C
- **Display:** LCD or LED for monitoring
- **Protection:** Overvoltage, overcurrent, and temperature protection
- **Communication:** Some models offer Bluetooth or Wi-Fi for remote monitoring
- **Regulation:** Advanced MPPT algorithm for maximum energy harvest
- **Battery Compatibility:** Works with different battery types (Lead-Acid, LiFePO4, Gel, etc.).

4.8 Battery

A twelve-volt battery has six single cells in series producing a fully charged output voltage of 12.6 volts. A battery cell consists of two lead plates a positive plate covered with a paste of lead dioxide and a negative made of sponge lead, with an insulating material (separator) in between.



Figure 4.9: 12V Battery

Specification

- Nominal Capacity: 200AH
- rechargeable 12v dc battery pack: 1PCS/CTN(according to the actual situation)
- Production Capacity: rechargeable 12v dc battery pack:50000PCS/Month
- Factory space: 6000m2
- Maintenance Type: Free
- Voltage: 12V

4.9 Pump Motor

A 12V water pump motor is a compact, efficient device designed to move water using a 12-volt DC power supply. Commonly used in small-scale applications such as aquariums, fountains, garden irrigation, and DIY projects, it typically features a brush or brushless motor. These pumps are lightweight, portable, and energy-efficient, making them ideal for solar-powered systems and low-voltage environments. They come in various flow rates and pressure ratings to suit different needs. With low maintenance and easy installation, 12V water pump motors are a reliable choice for transferring water in both indoor and outdoor applications.



Figure 4.10: Pump Motor

Specification

- Material: ABS(Acrylonitrile Butadiene Styrene) + Stainless Steel
- Overall Size: Approx. 80 x 48 x 63mm/3.15 x 1.89 x 2.48"
- Pump Inlet Diameter: 16mm(Outer), 12mm(Inner)
- Pump Outlet Diameter: 12mm(Outer), 6.9mm(Inner)
- Inlet/Outlet: 1/2" male thread
- Voltage: 12V DC
- Maximum Rated Current: 1.2A

- Power:16.8W
- Max Flow Rate: 700 L/H
- Max Water Head: 5M
- Max Circulating Water Temperature: 60°C

4.10 Easy EDA

Easy EDA is a web-based EDA tool suite that enables hardware engineers to design, simulate, share-publicly and privately-and discuss schematics, simulations and printed circuit boards. Other features include the creation of a bill of materials, Gerber files and pick and place files and documentary outputs in PDF, PNG and SVG formats. Easy EDA allows the creation and editing of schematic diagrams, SPICE simulation of mixed analogue and digital circuits and the creation and editing of printed circuit board layouts and, optionally, the manufacture of printed circuit boards.

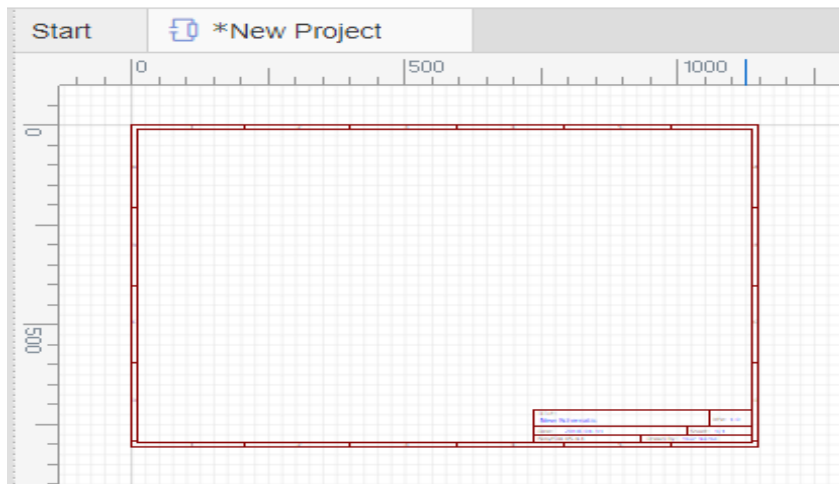

Figure 4.11: Easy EDA Software Interface

Subscription-free membership is offered for public plus a limited number of private projects. The number of private projects can be increased by contributing high quality public projects, schematic symbols, and PCB footprints and/or by paying a monthly subscription. Registered users can download Gerber files from the tool free of charge; but for a fee, Easy EDA offers a PCB fabrication service. This service is also able to accept Gerber file inputs from third party tools.

CHAPTER 5

RESULT ANALYSIS

5.1 Project Outcome

After finally completing this project, we ran it & we observed the output of this project. We can see that it is working well as expected. After making our project we observe it very careful. It works as we desire. Our project give output perfectly and all equipment are work perfectly. We check how much it works and we get perfect output from this project.

- Finally, we have completed our project successfully & check our project its run accurately according to our objective.
- At first, we start our system.
- The system successfully converts seawater into clear and potable water using the RO-based desalination process.
- Effective removal of dissolved salts, suspended particles, and impurities was observed after filtration and RO treatment.
- UV light disinfection ensured the elimination of harmful microorganisms, improving water safety.
- The DC pump motor operated efficiently using battery power, reducing energy losses and improving system reliability.
- The inverter successfully converted DC to AC power to activate the filtration unit without affecting overall performance.
- Solar panel and MPPT controller provided stable and efficient power management for continuous operation.
- The desalinated water met basic drinking water quality standards in terms of taste, clarity, and odor.
- Brine reject water was effectively separated, confirming proper membrane functioning.

Overall system performance demonstrated a cost-effective and eco-friendly solution to freshwater scarcity.

5.2 Complete Project prototype



Figure 5.1: Final View of Project

5.3 Project Result Analysis and Data Table

Table 02: Wasa Water Before Purification

Sample No.	TDS (ppm)	pH	EC ($\mu\text{S}/\text{cm}$)
1	230	08	461
2	230	09	461
3	230	08	461

Table 03 : Wasa Water After Purification

Sample No.	TDS (ppm)	pH	EC ($\mu\text{S}/\text{cm}$)
1	170	07	349
2	171	07	345
3	173	07	352

Table 04: Sea Water Before Purification

Sample No.	TDS (ppm)	pH	EC ($\mu\text{S/cm}$)
1	9719	08	9999
2	9719	09	9999
3	9719	08	9999

Table 05: Sea Water After Purification

Step-01

Sample No.	TDS (ppm)	pH	EC ($\mu\text{S/cm}$)
1	2542	07	5085
2	2577	07	5095
3	2538	07	5076

Step-02

Sample No.	TDS (ppm)	pH	EC ($\mu\text{S/cm}$)
1	652	07	1269
2	663	07	1280
3	634	07	1211

Step-03

Sample No.	TDS (ppm)	pH	EC ($\mu\text{S/cm}$)
1	243	07	487
2	257	07	510
3	224	07	463

- Potable water TDS range <500 ppm (BDS 1240:2001-BSTI)
- Potable water TDS range 50-300 ppm (WHO).

Testing Equipment



Figure 5.2: Litmus Paper

- **Litmus Paper:** Litmus paper is a simple and quick testing tool used to determine the pH level of water. When dipped in water, it changes color to indicate whether the water is acidic, neutral, or alkaline. Blue litmus paper turns red in acidic water, while red litmus paper turns blue in alkaline water. In this project, litmus paper is used to observe pH changes before and after the desalination process, which is essential for ensuring water safety and suitability for consumption.



Figure 5.3 : TDS Meter

- **TDS Meter :** A TDS meter is used to measure the total dissolved salts, minerals, and other invisible particles present in water. It determines the TDS value by measuring the Electrical Conductivity (EC) of the water, which is expressed in parts per million (ppm). This device plays an important role in checking water purity, especially in desalination and water treatment projects. By using a TDS meter, the water quality before and after the purification process can be compared, helping to evaluate the effectiveness of the system.

Result Analysis

- Artificial seawater was prepared using 30 g Sodium Chloride and 2 g Magnesium Sulfate per liter.
- After the desalination process, the remaining salt content was reduced to approximately 23 g per liter.
- A significant decrease in TDS and Electrical Conductivity (EC) was observed in the output water.
- The pH value after treatment was found to be near neutral, indicating improved water quality.
- The system effectively removed a major portion of dissolved salts and impurities.
- First-time battery charging required approximately 6 hours.
- Regular charging time was reduced to 3.5–3.6 hours, showing stable power performance.

5.4 Solar panel and battery performance data at different time periods

Serial No	Date & Time	Solar panel		Battery		Battery
		Voltage(V)	Curent(A)	Voltage(V)	Curent(A)	Charge(%)
1	16 Jan 26, 11 am	18.2	2.3	12.4	1.8	55
2	16 Jan 26, 12 pm	19.0	2.7	12.8	2.2	65
3	16 Jan 26, 01 pm	19.6	2.9	13.2	2.6	75
4	16 Jan 26, 02 Pm	18.8	2.5	13.5	2.1	85
5	17 Jan 26, 11 am	18.0	2.2	12.6	1.7	60
6	17 Jan 26, 12 pm	19.2	2.8	13.0	2.4	70
7	17 Jan 26, 01 pm	19.8	3.6	13.6	2.8	85
8	17 Jan 26, 02 pm	18.9	2.6	13.8	2.0	90

5.5 Advantages

There are certainly many advantages of our project and some of the major ones have been given below:

- Produces safe and potable drinking water from seawater
- Reduces dependence on limited freshwater sources
- Uses solar energy, making the system eco-friendly
- Suitable for coastal and remote areas
- Low operating and maintenance cost
- Efficient removal of salts and impurities
- DC pump reduces energy loss
- UV light improves water safety
- Compact and portable design
- Reliable solution for water scarcity

5.6 Application

The application areas for this project in this modern and practical world are huge and some of these are given below:

- Drinking water supply in coastal areas
- Freshwater production for islands
- Emergency water supply during disasters
- Use in remote and off-grid locations
- Drinking water for fishing boats and ships
- Military and border area water supply

5.7 Limitations

Through the project has many advantages it has also some limitation, they are given below:

- This project can now be only used for small scale purposes
- Dependence on sunlight for solar power
- Limited water output for large-scale demand
- This system does not include an energy backup facility.

5.8 Discussion

While working on our project, we did face some difficulties as it is a very complex system but the end results, we came up with were quite satisfactory. We have put the whole system through several tasks to validate our work and also have taken necessary notes for future improvements. Some future recommendations that we have involves improvement in system design and wiring, adding features for more efficient.

This project presents an effective solution to freshwater scarcity by combining solar energy with reverse osmosis desalination technology. The system efficiently converts seawater into potable water using a DC pump motor powered by a solar panel and battery, while an inverter supplies AC power to the filtration unit. Multi-stage filtration and UV treatment ensure improved water quality and safety. The project demonstrates reliable performance for small-scale applications, especially in coastal and off-grid areas. However, challenges such as dependence on sunlight, membrane maintenance, and brine disposal remain. Overall, the system proves to be an eco-friendly and practical approach to sustainable freshwater production.

CHAPTER 6

CONCLUSION

6.1 Conclusion

The Seawater Desalination Machine project successfully demonstrates a practical and sustainable method for producing potable water from seawater. By integrating reverse osmosis technology with a solar-powered energy system, the project addresses the growing challenge of freshwater scarcity, particularly in coastal and remote regions. The use of a DC pump motor powered directly from the battery improves energy efficiency, while the inverter effectively converts DC to AC to operate the filtration unit. Multi-stage filtration combined with UV disinfection ensures the removal of salts, impurities, and harmful microorganisms, resulting in safe drinking water.

The compact and modular design makes the system easy to install, operate, and maintain, making it suitable for small-scale domestic and community-level applications. Although challenges such as solar dependency, membrane fouling, and brine disposal exist, the project provides a strong foundation for further improvement. With future enhancements such as better energy storage, advanced membrane materials, and eco-friendly brine management, the system can be made more efficient and scalable. Overall, this project highlights the potential of renewable energy-based desalination as a reliable and environmentally responsible solution to global water scarcity.

6.2 Future Scope of Work

As we have already discussed about the limitations of our project so definitely there's room for improvement and thus, we have lots of future scope of work available to us for this project. Some of these are listed below:

- In future developments, this project can be implemented using microcontroller-based control.
- In future development this project can be develop by sensor.
- In future, I will try it to apply in real field.
- In Future develop add extra power system.
- In future integration with IoT for remote monitoring and control via smartphone apps.

REFERENCES

- [1] Gowtham, October 2012, Latent Heat Storage and Finned Type Solar Distiller, IACSIT International Journal of Engineering and Technology.
- [2] Ozuomba J.O.1, Edebeatu C.C.1, March 2012, The Performance of a Solar Water Distillation Kit fabricated Local materials Research, Journal of Chemical Sciences ISSN 2231-606X Vol. 2(3), 64-67
- [3] Carolina S.E., January 2012, implementation of the solar still principle on runoff water reservoirs in Butabuta solar still Distillation system.
- [4] Prof. Alpesh Mehta1., April 2011.s “4. Design of Solar Distillation, System International Journal of Advanced Science and Technology Vol. 29
- [5] Prof. Ayush Kaushal (2010), Amyloid–carbon hybrid membranes for universal water purification, Nature nanotechnology, vol. 11, no. 4, pp. 365, 2016.
- [6] Phalak, M. Kurkure, P. Bhangale, N. Deshmukh, V. Patil, 2017. Solar powered reverse osmosis water purifier, International Journal for Research in Engineering Application & Management (IJREAM), vol. 03, no. 01.
- [7] M. Z. H. Khan, M. R. Al-Mamun, S. C. Majumder, and M. Kamruzzaman, 2015, Water Purification and Disinfection by using Solar Energy: Towards Green Energy Challenge, Aceh Int. J. Sci. Technol., vol. 4, no. 3, pp. 99–106.
- [8] Hefei Zhang , Shaobo Hou , “A hybrid solar desalination process of the multi-effect humidification dehumidification and basin-type unit”, Desalination Vol. 220 (2008) Pages 552– 557
- [9] Lixi Zhang, Guangping Cheng, “A New Process of Solar Desalination Based on Humidification Dehumidification Cycle”, Proceedings of the International Multi Conference of Engineers and Computer Scientists, March 18 - 20, 2009, Hong Kong.
- [10] M. Amidpour, M. Zamen, S.M. Soufari, S. Abbasian Vahdat, , M.A. Zeinali, H. Izanloo, H. Aghababaie, “Experimental investigation of a two-stage solar Humidification dehumidification desalination Process”, Desalination, Volume 332, Issue 1, 2 January 2014, Pages 1–6
- [11] M. Abd Elkader, “Solar Seawater Desalination Using a Multi-Stage Multi-Effect Humidification (Meh)-Dehumidification System with Energy Storage”,

International Journal of Water Resources and Arid Environments 1(2): 116-122,
2011. ISSN 2079-7079

- [12] Julián Blanco, Eduardo Zarza, Diego Alarcón, Sixto Malato, Javier León, “Advanced Multi-Effect Solar Desalination Technology”.
- [13] I. Nasri, H. Abd, K. Abd, and M. A. Hakim,(2022) “Design of a Portable Solar Powered Water Desalination Device,”4(1)15–18.
- [14] D. Runze et al., (2020)“Experimental investigations on a portable atmospheric water generator for maritime rescue,” J. Water Reuse Desalin.,10(1)30–44, doi: 10.2166/WRD.2020.048.