

Department of Mechanical Engineering Sonargaon University (SU)

147/I, Green Road, Tejgaon, Dhaka-1215.



Course Title: Project & Thesis
Course Code: ME- 400

Analysis of Design and Implication of Automated Power Hammering Machine

Model of Analysis of Design and Implication of Automated Power Hammering Machine:

A thesis report submitted to the Department of Mechanical Engineering, Sonargaon University, in partial fulfillment of the requirements for the degree of "**Bachelor of Science in Mechanical Engineering**".

APPROVAL

This is to certify that the project on “Analysis of Design and Implication of Automated Power Hammering Machine” By Md. Jahid Hossain (ID Number: BME 1602009296), Md. Mamun Hossen Mazumder (ID Number: BME 1602009299), Solayman Ahmed (ID Number: BME 1602009303), Saikat Hasan Imon (ID Number: BME 1602009304) has been carried out under our supervision. The project has been carried out in partial fulfillment of the requirements of the degree of Bachelor of Science (B.Sc.) in Mechanical Engineering of years of 2020 and has been approved as to its style and contents.

Md. Minhaz Uddin

Lecturer

Mechanical Engineering
Sonargaon University (SU)

SUPERVISOR'S DECLARATION

I hereby declare to the Department of Mechanical Engineering Sonargaon University, Dhaka Bangladesh that I have checked this “**Analysis of Design and Implication of Automated Power Hammering Machine**” and in my opinion this thesis is satisfactory in terms of scope and quality for the partial achievement of the degree of Bachelor of Science in Mechanical Engineering.

Md. Minhaz Uddin

Lecturer

Mechanical Engineering
Sonargaon University (SU)

STUDENT'S DECLARATION

This is certified that the work presented in this thesis titled “**Analysis of Design and Implication of Automated Power Hammering Machine**” is outcome of the investigation carried out by authors under the supervision of **Md. Minhaz Uddin**, Lecturer, Department of Mechanical Engineering, Sonargaon University (SU). We also declare that no part of this project and thesis has been or is being submitted elsewhere for the award of any degree.

Submitted By:

1. Name: Md. Jahid Hossain

ID Number: BME 1602009296

B. Sc. of Mechanical Engineering

2. Name: Md. Mamun Hossen Mazumder

ID Number: BME 1602009299

B. Sc. of Mechanical Engineering

3. Name: Solayman Ahmed

ID Number: BME 1602009303

B. Sc. of Mechanical Engineering

4. Name: Saikat Hasan Imon

ID Number: BME 1602009304

B. Sc. of Mechanical Engineering

ACKNOWLEDGEMENT

We would like to thank Almighty Allah for the giving us the ability to work hard successfully. At very beginning we want to thanks our honorable Associate Professor & Head of the Department, Md. Mostofa Hossain of this valuable guidance at every stage of our study. We pray our gratitude to our supervisor, Md. Minhaz Uddin, Lecturer, Sonargaon University (SU) for his constant & meticulous supervision, valuable suggestion and encouragement to carry out this work. For all this, the authors acknowledge their sincere gratitude to him. We are also grateful to all our thesis & project working team of Sonargaon University (SU) for their help in construction of the project work and give their valuable knowledge and time for completing the experiment.

Finally we acknowledge with thanks the help of all members of Sonargaon University (SU) for their cordial cooperation and useful suggestions.

Authors:

- 1. Name: Md. Jahid Hossain**
ID Number: BME 1602009296
- 2. Name: Md. Mamun Hossen Mazumder**
ID Number: BME 1602009299
- 3. Name: Solayman Ahmed**
ID Number: BME 1602009303
- 4. Name: Saikat Hasan Imon**
ID Number: BME 1602009304

ABSTRACT

This paper discuss about “**Analysis of Design and Implication of Automatic Power Hammering Machine**”. Our goal for this paper is to “**Analysis of Design and Implication of Automated Power Hammering Machine**” And for this, we have calculated the maximum torque, impact velocity for hammering, torque force and also shear failure in bolt joint. In our project we are using torque force to perform various manufacturing operation in industries like riveting, upset forging, punching etc. Also time required for operation is less so it is useful in mass production. In this project we have prepared solid model of project. The snapshots of every component are attached in the file in design section. The model consists of motor, shaft, hammer, jigs and fixtures. From this we “**Analysis of Design and Implication of Automatic Power Hammering Machine**”. Automated power hammering machine is one of the new techniques proposed in design in order to achieve instant Hammering accurate repetition and impacting, fast Hammering process. It should be user friendly without any risk and worker manual Effort can be used easily automatically. In the past, a labor used hammer for to drive nail, fit parts, break apart and more. It would be used manually with more effort and man power used in process. But now a day it is possible to make it process easy by invented automatic Hammering. There are very clear benefits that the industry sees while using automated systems. These advantages can be very beneficial in the long run. We assure that our products are one of the best and they are long lasting.

Analysis of Design and Implication of Automated Power Hammering Machine

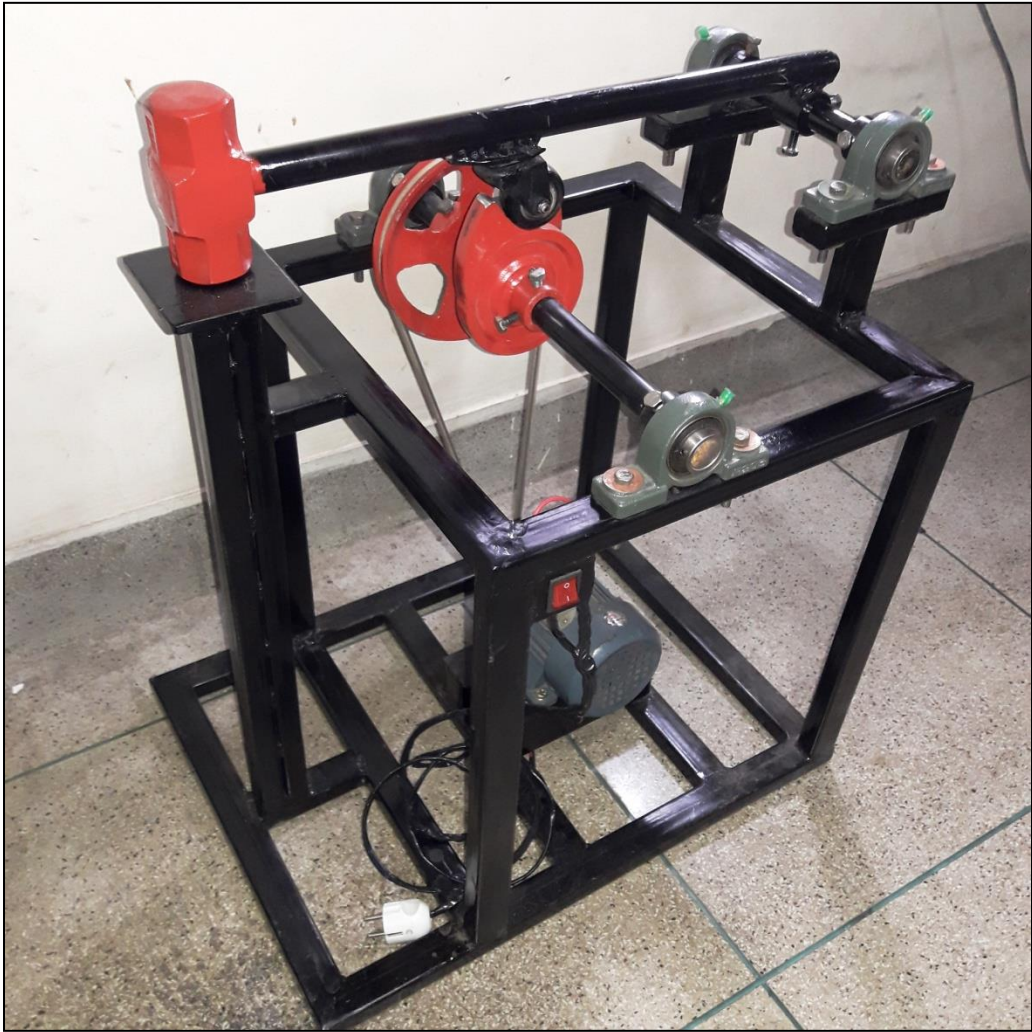

TABLE OF CONTENTS

Sl. No		Page No
1	APPROVAL	02
2	SUPERVISOR'S DECLARATION.....	03
3	STUDENT'S DECLARATION	04
4	ACKNOWLEDGEMENT	05
5	ABSTRACT	06
6	TBALE OF CONTENTS	08
7	LIST OF FIGURRES	10
CHAPTER 1	<u>INTRODUCTION</u>	11-12
	1.1. General Power Hammer	11
	1.2. Objective of Projects	11
	1.3. About of Project Work	11
	1.4. Project Means	12
CHAPTER 2	<u>LITERATURE REVIEW</u>	13-19
	2.1. History & Development of Power Hammer	13
	2.2. Forging	13
	2.1.1. Forging Processes	14
	2.1.2. Press	14
	2.1.3. Types of Processes	15
	2.1.4. Press Tool Operations	17
	2.3. Types of Power Hammer	17
	2.4. Analytical Techniques	19
	2.5. Features are Power Hammer	19

CHAPTER 3	<u>METHODOLOGY</u>	20-31
	3.1. Working Process	20
	3.2. Block Diagram	20
	3.3. Circuit Diagram	21
	3.4. Working Principal	21
	3.5. Required Instruments	22
	3.5.1. Supporting Frame	22
	3.5.2. Motor	23
	3.5.3. Motor Driver (Belt)	25
	3.5.4. Pulley	26
	3.5.5. Cam & Cam Shaft	27
	3.5.6. Connecting Rod	28
	3.5.7. Hammer	29
	3.5.8. Ball Bearing	30
	3.5.9. Mounts & Joints	31
	3.5.10. Light Duty Wheel	31
CHAPTER 4	<u>DESIGN AND CALCULATION OF HAMMERING MACHINE</u>	32-35
	4.1. Analysis of Some Existing Design	32
	4.2. Calculation	33
	4.2.1. To Calculate maximum Torque by Motor	33
	4.2.2. To Find Torque Force Transmitted	34
	4.2.3. To Find Impact velocity of Hammer	34
	4.2.3.1. Result	35
	4.2.4. To Calculate Shear Stress in Bolt Joints	35
	4.2.4.1. Result	35
CHAPTER 5	<u>RESULT AND DISCUSSION</u>	36-36
	5.1. Result	36
	5.2. Discussion	36

CHAPTER 6**CONCLUSION****37-39**

6.1. Advantages	37
6.2. Disadvantage	37
6.3. Applications	37
6.4. Future Scope	37
6.5. Conclusion	38
6.6. Reference	39

LIST OF FUGURE

Figure No.	Figure Name	Page No.
Figure: 3.2.1.	Block Diagram of Automated Power Hammering Machine	20
Figure: 3.3.1.	Block Diagram of Automated Power Hammering Machine	21
Figure: 3.5.1.1.	Supporting Frame of Hammering Machine	22
Figure 3.5.2.1.	Motor	23
Figure 3.5.2.2.	AC Motor	24
Figure: 3.5.3.1.	Motor Drive (Belt)	25
Figure: 3.5.4.1.	Pulley	26
Figure: 3.5.5.1.	Cam & Cam Shaft	27
Figure: 3.5.6.1.	Connecting Rod With Hammer	28
Figure: 3.5.7.1.	Hammer	29
Figure: 3.5.8.1.	Ball Bearing	30
Figure: 3.5.9.1.	Mounts & Joints	31
Figure: 3.5.10.1.	Light Duty Wheel	31
Figure: 4.1.1.	Automated Power Hammering Machine	32
Figure: 4.2.1.1.	Free Body Diagram	33

CHAPTER 1

INTRODUCTION

1.1. GENERAL POWER HAMMER:

Power hammer is one type of machine tool which is used in forging operation. This machine use power source for up-down the hammer to being hammered any parts or components. They have been used by blacksmiths since 1880s, by replacing trip hammers. Generally power hammer consists of Ram, Frame, Anvil, Hammer head, Dies, Connecting Rod, Leaf Spring and power source like electric motor.

Simply, power hammer is the machine tool which uses the electric power source to run the motor and this rotary motion of the motor is utilize to reciprocate the ram by attaching the leaf spring between ram and connecting rod.

In this invention we have been modeling the machine in the software and made a simple and compact layout of the machine as per requirement of forging operations.

1.2. OBJECTIVES OF PROJECTS:

- To determination of impact velocity and torque force of hammer.
- To determine the time required for the various operations.
- To prepare the modeling of project.
- To automation with minimum man power.
- To low initial and operating cost.
- To as time required in less useful in mass production.

1.3. ABOUT OF PROJECT WORK:

The aim of course can achieve by learning in classroom and laboratory. However, threw the project something extra knowledge can achieve.

- ❖ **To develop planning, designing and manufacturing skill.**
- ❖ **To provide inter disciplinary studies.**
- ❖ **To develop higher level skill.**
- ❖ **To develop the spirit of the work and be mature.**
- ❖ **To develop ability for teamwork.**

We have a chance for applying our knowledge obtained during B. Sc. Mechanical program. We have been through many things like flexibility study, designing, drafting, process planning, costing, management and spirit of team work. As we make “**Automated Power Hammering Machine**” to forging.

1.4. PROJECT MEANS:

- **PLANNING BEFORE CARRYING OUT THE WORK.**
- **ROW MATERIAL REQUIRED FOR THE WORK.**
- **ORGANIZATION OF THE WORK**
- **JOINT EFFORTS PUT TOGETHER IN THE WORK.**
- **ESTIMATION OF THE MATERIAL REQUIRED IN THE WORK.**
- **COSTING OF THE WORK**
- **TECHNIQUES**

CHAPTER 2

LITERATURE REVIEW

2.1. HISTORY & DEVELOPMENT OF POWER HAMMER:

Until now we have confined ourselves to study of hand tools used in smithy work. They certainly perform very well so far as the hand forging is concerned but their use for satisfactory production is limited to small forging only. It would not be difficult to understand hand the intensity of blows, however great one may try to achieve through hand hammering, will not be sufficient enough to effect the proper plastic flow in a medium sized or heavy forging. For this, a power hammer is usually employed. The capacity of these hammers is given by the total weight of their falling parts i.e. ram and die. A 200 kg hammer will be one of which the falling parts weight 200kg. The heavier these parts and greater the height from which they fall. The higher will be

Intensity of blow the hammer will provide. Power hammers in common use are of different types e.g. spring power hammers, pneumatic power hammers. Steam hammers and drop or forge hammers and six bar slider crank power hammers. These hammers are named partly after their construction, partly according to their way of operation. Apart from these, a large number of forging presses and machines are used in forging work. In the following articles these hammers and machines will be discussed in detail.

2.2. FORGING:

Forging refers as the processes of plastically deforming metals or alloys to a specific shape by a compressive force exerted by some external agency like hammer, press, rolls etc by an upsetting machine of some kind. The portion of a work in which forging is done is termed the forge and the work is mainly performed by means of heavy hammers, forging machines and presses. Forging processes are among the most important manufacturing techniques since forging is used in small tools, railroad equipment, automobile and aviation industries.

A number of operations are used to change the shape of the raw material to the finished form. The typical forging operations are:

- **Upsetting**
- **Drawing down**
- **Setting down**
- **Punching**
- **Bending**
- **Welding**
- **Cutting**

All these operations are carried out with the metal in a heated condition, which must be maintained by taking a “Fresh” heat when the work shows sign of getting cold.

2.2.1. FORGING PROCESSES

The processes of reducing a metal billet between flat-dies or in a closed impression die to obtain a part of predetermined size and shape are called smith forging and impression die forging respectively. Depending on the equipments utilized they are further sub-divided as hand forging, hammer forging, press forging, drop forging, mechanical press forging, upset or machine forging.

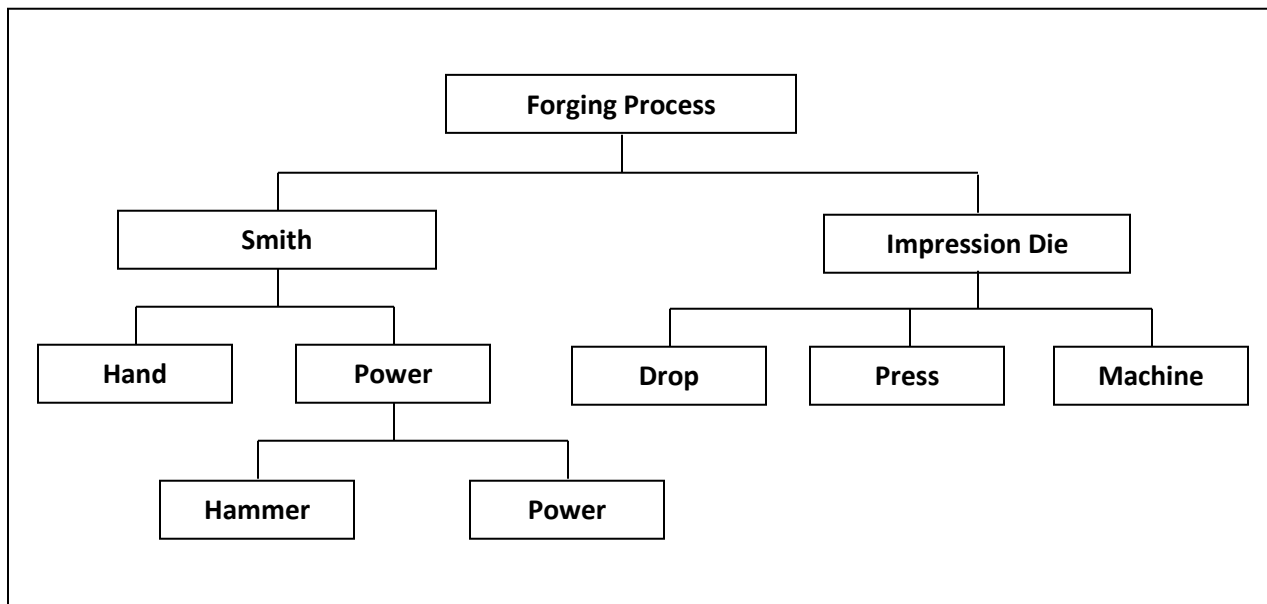

Figure: 2.2.1.1. Classification of forging processes.

2.2.2. PRESS:

Press working involves production of final component from sheet metal in cold condition. The mechanic which is used to apply the required pressure of force in a short duration is called press. The press consists of a frame, supporting bed and ram. The ram is equipped with special punches and moves towards and into the die block which is attached to a rigid body. The punch and die block assemble are generally referred to as a die set or simply die.

A disadvantage of press working is that the operation is carried out at room temperature and the metal is less deformable of strain hardening.

2.2.3. TYPES OF PROCESSES:

The presses are available in different designs and shapes, according to the work requirement. This article throws light upon the sixteen main types of presses. Some of the types are:

1. Manually Operated (Fly) Press
2. Electric Motor Operated Press
3. Hydraulic Press
4. Inclined Press
5. Inclinal Press
6. Gap Press
7. Arch Press
8. Straight-Side Press

1. Manually Operated (Fly) Press:

The press is operated by human hands. It is a bench mounted press commonly used for the production of small components. It is a simple and low cost press, suitable for light operations, like piercing, blanking, bending, etc, the arm is rotated manually, the ram moves, up and down to perform the necessary operation. The ram is fitted with punch and the job is resting on the bed.

2. Electric Motor Operated Press:

The press is operated by an electric motor. The motor drives the crank shaft which converts the rotary motion into reciprocating motion of the ram. The ram fitted with the punch, to operate upon the job held on the die block and bolster.

The electric motor supplies energy to the fly wheel and this energy are transferred to the ram via a clutch and crankshaft.

- (a) Non-geared (fly wheel) type.
- b) Single reduction gear type.
- (c) Double reduction gear type.
- (d) Multiple reduction gear type.

3. Hydraulic Press:

The hydraulic press uses the water or oil pressure to moves the slide and ram up and down. A Pump is employed to supply the liquid under high pressure to the cylinder.

An accumulator system is used to store the liquid and then to supply suddenly a large volume of liquid at a constant pressure in seconds of time. In self-contained type hydraulic presses, accumulator is not used. All the energy is applied directly to the cylinder by the pump.

Hydraulic presses are available in capacities up to 15000 tons. Hence, these presses are specially employed for drawing, extruding, piercing and blanking of metals above 3mm thickness.

4. Inclined Press:

As its name indicates, it has an inclined frame.

5. Inclinal Press:

An inclinable press has an adjustable frame. It can be used for vertical as well as any inclined position.

6. Gap Press:

A Gap-press also called C-Press. It has an open throat that provides excellent gap around the dies. Such type of press allows the use of very long and wide work parts.

7. Arch Press:

It has an arch-shaped frame. It is used for light work. Some products manufactured by this press are; Paint cans, shovels etc.

8. Straight-Side Press:

It has high capacity of work. It has a rigid frame and is used in mechanical and hydraulic presses where heavy loads are produced. These types of presses are used for forming of heavy and thick metals, coming, deep drawing, etc.

2.2.4. PRESS TOOL OPERATIONS:

A large number of operations can be performed by using press tools and all press tool operations can be broadly classified into two types:

➤ **CUTTING OPERATIONS:**

- a. Blanking
- b. Piercing
- c. Lancing
- d. Cutting off and parting
- e. Notching
- f. Shaving
- g. Trimming

➤ **SHAPING OPERATIONS:**

- a. Forming (Embossing, Beading, Cutting etc.)
- b. Drawing
- c. bending

2.3. TYPES OF POWER HAMMERS

HELVE HAMMER:

Helve hammers are well adapted for general engineering work where the size of the stock is changed frequently. They consist of a horizontal wooden helve, pivoted at one end with a hammer at the other end. An adjustable eccentric raises the hammer which when falls strikes a below. They are made in sizes from 5 to 200kg.

TRIP HAMMER:

Trip hammers have a vertically reciprocating ram that is actuated by toggle connection driven by a rotating shaft at the top of the hammer. Trip hammers are also built in size from 5 to 200kg. The stroke range of both helve and trip hammers ranges from about 400 per minute for small sizes to about 175 for large size.

LEVER SPRING HAMMER

They are mechanical driven hammers with a practically constant lift and an insignificantly variable striking power. It only increases with increasing operating speed and thus has increases number of strokes per minute. The ram is driven from rocking lever acting on an elastic rod. The rocking lever consists of a leaf spring so that an elastic drive is brought about.

They are suitable for drawing out and flattening small forging produced in large numbers. Their disadvantage is the frequent breaking of springs due to vibrations when in operations.

Spring hammers are built with rams weighing from 30 to 250 kg. The number of strokes varies from 200 to 400 blows per minute.

PNEUMATIC HAMMER

The hammer has two cylinders compressor cylinder and ram cylinder. Piston of the compressor cylinder compresses air and delivers it to the ram cylinder where it actuates the piston which is integral with ram delivering the blows to the work. The reciprocation of the compression piston is obtained from crank drive which is powered from a motor through a reducing gear. The air distribution device between the two cylinders consist of rotary valves with ports through which air presses into the ram cylinder, below and above the piston, ultimately. This drives the ram up and down respectively.

HYDRAULIC HAMMER

In this hammers instead of air oil was used. The cost hydraulic hammer is high as compared to the pneumatic hammers. Hydraulic hammer is used in high force applications. These are noise less.

2.4. ANALYTICAL TECHNIQUES:

Analytical methods can also be used to achieve precise results. Advanced analytical techniques often involve intense mathematical CALCULATION. In addition, the significance of the calculations is often difficult to visualize. The analytical techniques incorporated in this text couple the theories of geometry, CAD Modeling and graphical mechanism analysis. This approach will achieve accurate solutions, yet the CAD modeling of automatic hammering machine graphical theories allow the solutions to be visualized. A significant of automatic hammering machine dedicated to these analytical techniques.

2.5. FEATURES ARE POWER HAMMER:

- ❖ Instant Hammering.
- ❖ Fast Hammering Process.
- ❖ No Manual Effort.
- ❖ Portable System.
- ❖ Low Initial Cost.
- ❖ Low Tooling Cost.
- ❖ Accurate Repetition and Impact.
- ❖ User Friendly.
- ❖ Easy Maintenance.

CHAPTER 3

METHODOLOGY

3.1. WORKING PROCESS:

Hammering is the most widely used industrial as well as construction activity. Hammering or screws, metal sheets, parts etc requires a lot of time and effort. So here we propose an automated hammering system that allows for fully automatic hammering process. This allows for accurate, fast and automated hammering wherever and whenever needed using a 12V battery or Electric supply. The person just needs to insert workpeice and start the hammering machine. This machine can be used for automatic hammering work as and when needed. We here use a dc motor in order to move the hammer. The DC motor consists of a pulley attached to it which is connected to a larger pulley for efficient power transfer and to increase torque. This large pulley is connected to a shaft that has a connecting rod attached to it. This rod is used to achieve lateral motion from the spinning shaft. We now connect the other end of hammer to this connecting rod through a mid swinging arrangement in order to achieve desired hammer motion with enough torque. We now use a suitable bed where workpeice can be placed.

3.2. BLOCK DIAGRAM:

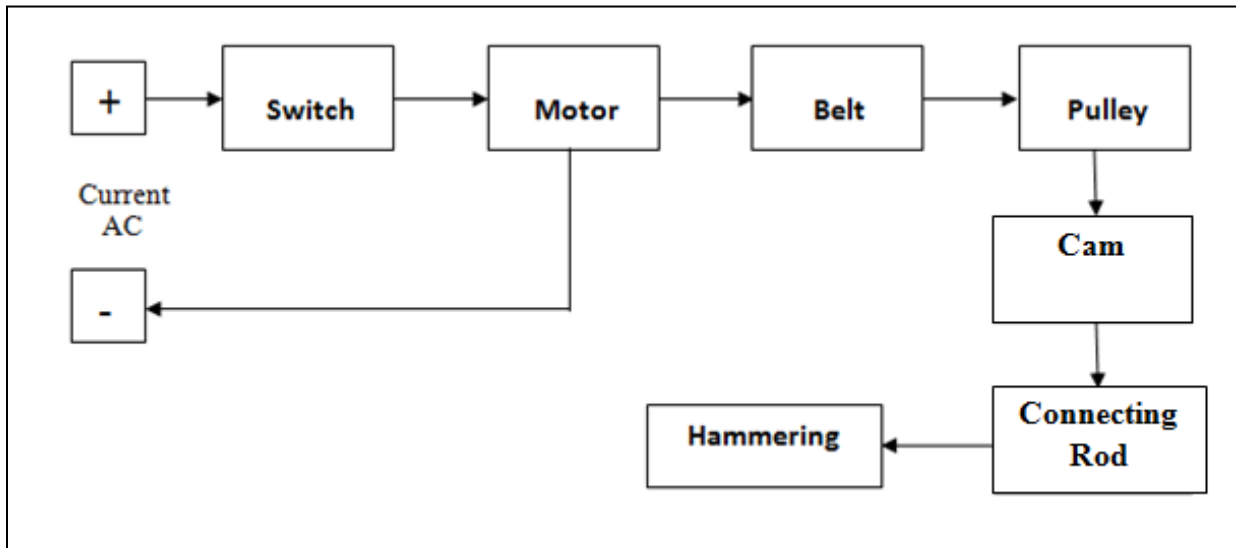

Figure: 3.2.1. Block Diagram of Automated Power Hammering Machine

3.3. CIRCUIT DIAGRAM:

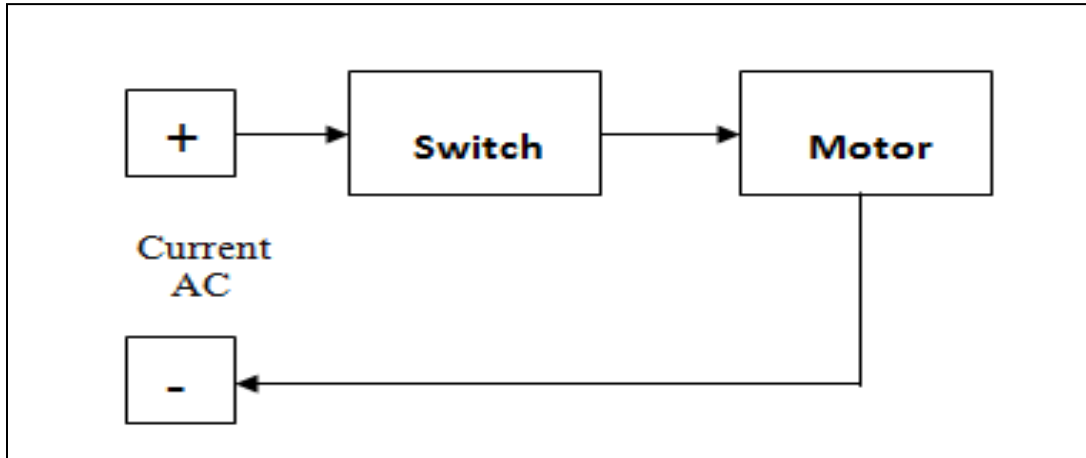

Figure: 3.3.1. Block Diagram of Circuit of Automated Power Hammering

3.4. WORKING PRINCIPAL:

This project has various different design paths to complete our products while matting the objectives. these means we will have to implement and compare our different design to insure the best product on our sat of objectives .this paths have changed as we progressed through our project, and there were few fore seen methods that we expand upon in the design section.

The basic design for automatic hammering machine is to have motor fixed on stand, and then motor shaft is inserted in center hole of the disc. Disc is connected to the hammer rod with the link rod when we supply the dc current to the dc motor by using adopter then the motor shaft start rotating further transmit the spinning motion to the disc by using shaft the first decision is to create an impact force for the respective operation this will help to determine product affordability.

A more efficient yet expensive design would be to have battery instead of adopter. There is bound to be various obstacles and design method to be implemented as projected progressives and will be observed and recorded as they occur.

3.5. REQUIRED INSTRUMENTS:

1. Supporting Frame
2. Motor
3. Motor Driver (Belt)
4. Pulley
5. Cam & Cam Shaft
6. Connecting Rod
7. Hammer
8. Ball Bearing
9. Mounts & Joints
10. Light Duty Wheel

3.5.1. SUPPORTING FRAME:

A supporting frame is being used to properly hold the entire component in a power hammering machine. The frame is made of steel. The most important element for power hammering machine is the frame.

Specification:

1. Length: 605 mm (60.5 cm)
2. Wide: 455 mm (45.5 cm)
3. Height: 507 mm (50.7 cm)
4. Material: 38.1 mm (3.81 cm)/ 25.4 mm (2.54 cm) steel box



Figure: 3.5.1.1. Supporting Frame of Hammering Machine

3.5.2. MOTOR:

A **DC motor** is any of a class of rotary electrical machines that converts direct current electrical energy into mechanical energy. The most common types rely on the forces produced by magnetic fields. Nearly all types of DC motors have some internal mechanism, either electromechanical or electronic; to periodically change the direction of current flow in part of the motor.

DC motors were the first form of motor widely used, as they could be powered from existing direct-current lighting power distribution systems. A DC motor's speed can be controlled over a wide range, using either a variable supply voltage or by changing the strength of current in its field windings. Small DC motors are used in tools, toys, and appliances. The universal motor can operate on direct current but is a lightweight brushed motor used for portable power tools and appliances. Larger DC motors are currently used in propulsion of electric vehicles, elevator and hoists, and in drives for steel rolling mills. The advent of power electronics has made replacement of DC motors with AC motors possible in many applications.

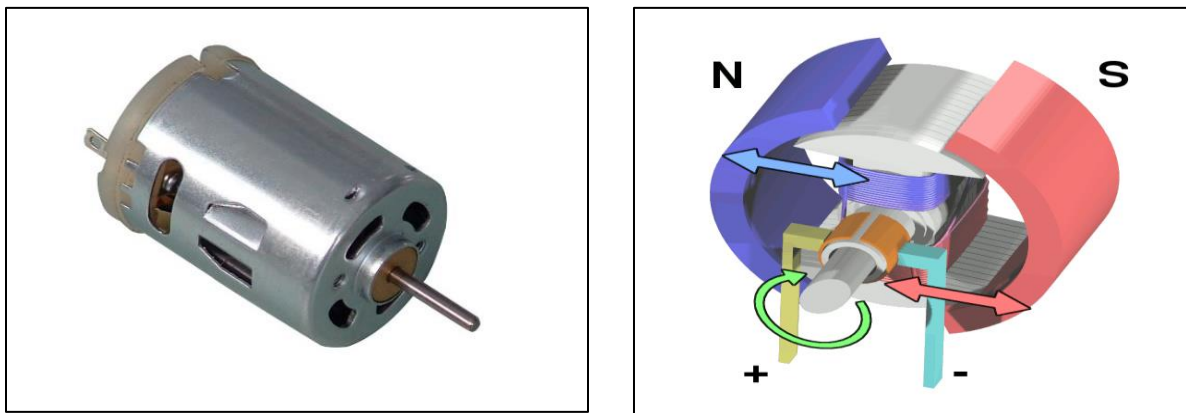

Figure 3.5.2.1: Motor

A coil of wire with a current running through it generates an electromagnetic field aligned with the center of the coil. The direction and magnitude of the magnetic field produced by the coil can be changed with the direction and magnitude of the current flowing through it. A simple DC motor has a stationary set of magnets in the stator and an armature with one or more windings of insulated wire wrapped around a soft iron core that concentrates the magnetic field. The windings usually have multiple turns around the core, and in large motors there can be several parallel current paths. The ends of the wire winding are connected to a commutator.

The commutator allows each armature coil to be energized in turn and connects the rotating coils with the external power supply through brushes. (Brushless DC motors have electronics that switch the DC current to each coil on and off and have no brushes). The total amount of current sent to the coil, the coil's size and what it's wrapped around dictate the strength of the electromagnetic field created.

A Direct Current (DC) motor is a rotating electrical device that converts direct current, of electrical energy, into mechanical energy. An Inductor (coil) inside the DC motor produces a magnetic field that creates rotary motion as DC voltage is applied to its terminal. Inside the motor is an iron shaft, wrapped in a coil of wire. This shaft contains two fixed, North and South, magnets on both sides which cause both a repulsive and attractive force, in turn, producing torque.

Specification:

- 1. Motor Speed: 1400 rpm**
- 2. Power: 120W**
- 3. Rated voltage: AC 220v**
- 4. Current: 12 A**
- 5. Frequency: 50 Hz**



Figure 3.5.2.2: AC Motor

3.5.3. MOTOR DRIVE (BELT):

A belt is a looped strip of flexible material used to mechanically link two or more rotating shafts. A belt drive offers smooth transmission of power between shafts at a considerable distance. Belt drives are used as the source of motion to transfer to efficiently transmit power or to track relative movement.

Specification:

- 1. Length: 940 mm (9.40 cm)**
- 2. Thickness: 5 mm (0.05 cm)**
- 3. Material: Rubber (V belt)**



Figure: 3.5.3.1. Motor Drive (Belt)

3.5.4. PULLEY:

A pulley is a wheel on an axle or shaft that is designed to support movement and change of direction of a belt. Transfer of power between the shaft and belt. In the case of a pulley supported by a frame or shell that does not transfer power to a shaft, but is used to guide the belt a force, the supporting shell is called a block, and the pulley may be called a sheave.

A pulley may have a groove or grooves between flanges around its circumference to locate the belt. The drive element of a pulley system can be a rope, cable, belt, or chain.

Specification:

- 1. Inner Diameter: 25.4 mm (2.54 cm)**
- 2. Outer Diameter: 101.6 mm (1.016 cm)**
- 3. Thickness: 20 mm (0.2 cm)**



Figure: 3.5.4.1. Pulley

3.5.5. CAM & CAM SHAFT:

A cam is a rotating or sliding piece in a mechanical linkage used especially in transforming rotary motion into linear motion. It is often a part of a rotating wheel (e.g. an eccentric wheel) or shaft (e.g. a cylinder with an irregular shape) that strikes a lever at one or more points on its circular path.

The **camshaft** is the basic function of an hammer machine. Comprised of two distinct parts, the cams and the shaft, the **camshaft** is the element that enables connecting rod to up and down. As the shaft rotates, the egg-shaped cams (or "lobes") push the connecting rod up and down in sync with the pulley.

Specification:

- 1. Inner Diameter of Cam: 101.6 mm (1.016 cm)**
- 2. Outside Diameter: 203.2 mm (2.032 cm)**
- 3. Cam Head Height: 50.8 mm (5.08 cm)**
- 4. Cam Shaft Wide: 20.32 mm (2.032 cm)**
- 5. Cam Shaft Diameter: 30 mm (0.3 cm)**



Figure:3.5.5.1. Cam & Cam Shaft

3.5.6. CONNECTING ROD WITH HAMMER:

A **connecting rod** is a hammer machine component that transfers motion from the hammer to the camshaft and functions as a lever arm. **Connecting** rods are commonly made from steel and are designed to withstand dynamic stresses from hammer machine and **hammer** movement.

Specification:

- 1. Connecting Rod Length With hammer: 600 mm (6cm)**
- 2. Connecting Rod Diameter: 30 mm (0.3 cm)**
- 3. Material: Steel Pipe**



Figure: 3.5.6.1. Connecting Rod with Hammer

3.5.7. HAMMER:

In this project we have used hammer having weight 1.80 kg for various operations such as punching, upset forging, riveting, etc. these types of manufacturing operations in manufacturing industries.

Specification:

- 1. Weight: 1.80 kg**
- 2. Length: 120 mm (1.20 cm)**
- 3. Wide: 50 mm (05 cm)**



Figure: 3.5.7.1. Hammer

3.5.8. BALL BEARING:

A **ball bearing** is a type of rolling-element **bearing** that uses **balls** to maintain the separation between the **bearing** races. The **purpose of a ball bearing** is to reduce rotational friction and support radial and axial loads.



Figure: 3.5.8.1. Ball Bearing

3.5.9. MOUNTS & JOINTS:

A mechanical **linkage** is an assembly of bodies connected to manage forces and movement. The movement of a body, or link, is studied using geometry so the link is considered to be rigid. The connections between links are modeled as providing ideal movement, pure rotation or sliding for example, and are called joints.



Figure: 3.5.9.1. Mounts & Joints

3.5.10. LIGHT DUTY WHEEL:

A **caster** (also known as castor according to some dictionaries) is a wheeled device typically mounted to a larger object that enables relatively easy rolling movement of the object. **Casters** are essentially housings that include a **wheel** and a mounting to install the **caster** to objects (equipment, apparatus and more).



Figure: 3.5.10.1. Light Duty Wheel

CHAPTER 4

DESIGN AND CALCULATION OF HAMMERING MACHINE

4.1. ANALYSIS OF SOME EXISTING DESIGN:

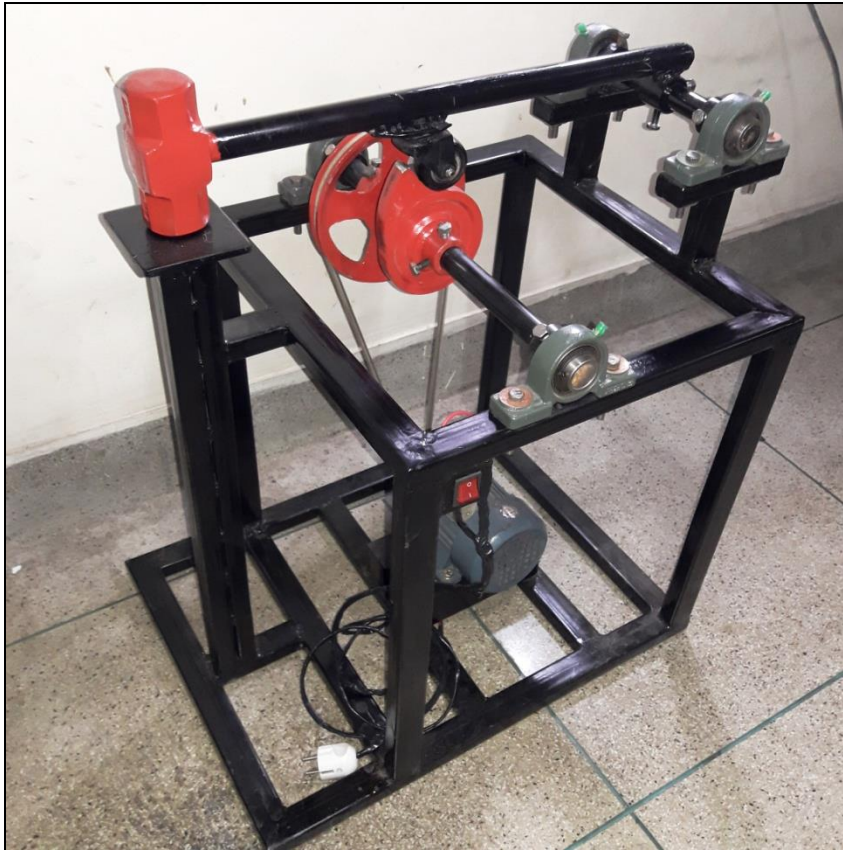

Figure: 4.1.1. Automated Power Hammering Machine

The most reliable design of automatic hammering machine are described below along with their specification in order to show the different existing approaches to the small and portable automatic hammering concept. These data could be useful when performing the initial sizing in the design stage of automatic hammering machine project. Following are designs for initial data collection:

- Total weight = 15 kg.
- Hammer weight = 1.8 kg.
- Hammer length = 120 mm.
- Hammer stroke height = 76.2 mm.
- Width = 455 mm.
- Height = 507 mm.
- Length = 605 mm.

- Supply voltage = AC 220v.
- Motor = 1400 RPM, 120w. AC motor.
- Diameter of pulley = 101.6 mm.
- Length of Belt = 940 mm.
- Typical operation = By belt.

4.2. CALCULATION:

4.2.1. A) To calculate maximum torque by motor:

❖ Motor rating,

Given Data:

$$N = 1400 \text{ RPM}$$

$$I = 12 \text{ A}$$

$$V = 220\text{v}$$

❖ Power Transmitted by Motor,

$$P = V \times I$$

$$= 220 \times 12$$

$$= 2640 \text{ W}$$

$$P = 2 \pi NT/60$$

$$2640 = 2\pi 1400 \times T / 60$$

$$T = 17.78 \text{ N-m}$$

❖ Distance of rod BA,

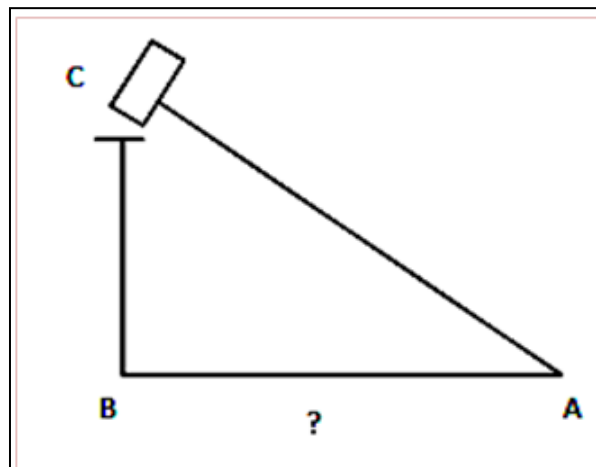

Figure: 4.2.1.1. Free Body Diagram

- ❖ To find the distance of BA,

By Pythagoras theorem

$$(AB)^2 + (BC)^2 = (CA)^2$$

$$(AB)^2 + (620)^2 = (940)^2$$

$$(AB) = 706.54 \text{ mm}$$

4.2.2. B) To find torque force transmitted we have two cases:

- ❖ **CASE 1: When Hammer Moves Downward.**

Given:

$$(BC) = h = 620 \text{ mm} = 0.62 \text{ m}$$

$$\text{Maximum torque} = 17.78 \text{ N-m}$$

$$\text{Length of hammer rod} = 500 \text{ mm}$$

$$= 0.5 \text{ m}$$

$$\text{Torque Force} = T_{\text{max}}/h \times \text{Length of hammer rod}$$

$$T_f = 17.78/0.62 \times 0.5$$

$$T_f = 14.34 \text{ N-m.}$$

- ❖ **CASE 2: WHEN HAMMER GOES UPWARD, TORQUE FORCE WILL BE DECREASED**

$$\text{Torque Force} = T_{\text{max}}/h \times \text{Length of hammer rod} - \text{Weight of hammer}$$

$$= 17.78/0.62 \times 0.5 - 14.71$$

$$T_f = 42.64 \text{ N-m}$$

4.2.3. C) TO FIND IMPACT VELOCITY OF HAMMER:

Given:

$$H = 620 \text{ mm} = 0.62 \text{ m}$$

$$T \text{ (time required for one revolution of Disc)} = 2 \text{ sec.}$$

So,

$$V = h \times T$$

$$V = 0.62 \times 2$$

$$V = 1.24 \text{ m/sec}$$

So the impact velocity of hammer is 1.24 m/sec.

4.2.3.1. RESULT:

Calculated the impact velocity is 1.24 m/sec with a torque force of 7.92 N-m is sufficient and it is calculated successfully.

4.2.4. D) TO CALCULATE SHEAR STRESS IN BOLTED JOINT:

We have bolted joints so there is torsional shear stress in joints,

We have,

$$T = 30.55 \text{ N-m.}$$

$$d = \text{Diameter of bolt } 10 \text{ mm.}$$

$$J = \text{polar moment of inertia.}$$

$$J = \pi/64 \times (0.1)^4 \\ = 4.90 \times 10^{-6} \text{ m}^4$$

$$T/J = \tau/r$$

$$30.55/4.90 = \tau/0.05 \quad (r = d/2=0.05 \text{ mm})$$

$$\tau = 311.73 \times 103 \text{ N/m}^2$$

4.2.4.1. RESULT:

As the standard permissible value of shear stress for M10 bolt is $396.8 \times 103 \text{ N/mm}^2$ and the calculated value of shear stresses is $311.73 \times 103 \text{ N/m}^2$ so Therefore the value of shear stress is less than permissible shear stress the design is safe.

CHAPTER 5

RESULT AND DISCUSSION

5.1. RESULT:

Finally, we were able to create our project successfully. After making the Mechanical body, we designed a circuit to control it and when we operated it with electricity; we called it working pretty well. It is very well controlled and is again able to hammering very well. Below is a picture of our successfully completed entire project.

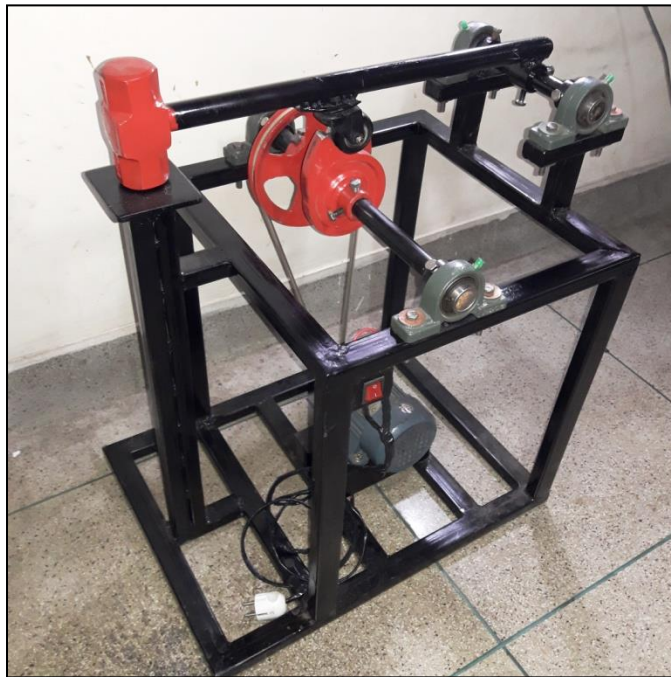

5.2. DISCUSSION:

To use a hammer, we have to take different steps at different times. We usually have to work with the help of people to use a hammer. It takes more time and more time to work. If we use a hammer machine but the amount of people will be less, that is, one can work. It will take less time and work faster. For example, for those who work in the blacksmiths, this is a very important machine. It will be take less for people to do their work and it will be done quickly and the importance of this lies in the functioning of the hammering at the Automobile service centers. The amount of physical work that people do for them will be reduced. With the use of this machine, the efficiency of his work will increase faster than ever. By doing so, the family and the country itself can benefit.

CHAPTER 6

CONCLUSION

6.1. ADVANTAGES:

- ❖ Available in wide variety of sizes.
- ❖ Maintain good control and required force.
- ❖ Low cost.
- ❖ Save man power.
- ❖ Saves time.
- ❖ Time delay can be achieved easily.
- ❖ Mass production.

6.2. DISADVANTAGES:

- ❖ This mechanism is only suitable for few operations.
- ❖ As torque force required is more there is difficult to find the motor to achieve the required torque.
- ❖ Having little wear.

6.3. APPLICATION OF POWER HAMMER:

- In manufacturing industries to perform different operations as follows.
- To perform smithy operation i.e. upset forging.
- To perform the punching operation.
- To perform filleting operation as torque force produce is sufficient for the operation.
- To perform riveting operation etc.

6.4. FUTURE SCOPE:

The concept of an automatic hammering machine in this paper has been shown to have a place in the actual market and to fill a need demanded by potential customer. IN this paper, the concept of automatic hammering machine prototype will have to fulfill the basic design requirement, let us add the proposed concept will a few more lines about our impression project work. Help in production line where many workers are used for the material handling purpose it also reduce the cost and threshing time requirement of more number of worker will completely eliminated as only two workers can carried out the be complete operation. The project objective originally is to reduce human efforts in manufacturing industries. The in future the complete stress analysis of the project model could be done. This analysis could be done by us. Moreover, for the automatic hammering machine to achieve fully success in the future, many collateral improvement must be done in terms of systems (autopilot technology, for instant) and time delay management (pedal operated control will be required) and some modification can will be done in this project.

6.5. CONCLUSIONS:

We have successfully calculated the torque force of the motor. For the design the impact velocity and torque force for riveting of 2 mm rivet is calculated accurately. The entire modeling of the project is done with the help. The project work has provided us an excellent opportunity and experience, to use our limited knowledge. We gained a lot of practical knowledge regarding. Planning, Perching, assembling and machining while doing this feel that the project work is good solution to bridge the gates project work between institutions and industries. We are proud that we have completed the work with limited time successfully Automatic hammering machine is working with satisfactory condition. We have done to our ability and skill making a work.

6.6. REFERENCE:

1. International Research Journal of Engineering and Technology (IRJET), www.irjet.net, <https://www.irjet.net/archives/V5/i4/IRJET-V5I4209.pdf>
2. Power hammer, From Wikipedia, https://en.wikipedia.org/wiki/Power_hammer#History
3. Slideshare, <https://www.slideshare.net/achalpatell/power-hammer-project>
4. Nevonprojects, nevonprojects.com, <https://nevonprojects.com/automated-portable-hammering-machine/>
5. Skyfilabs, <https://www.skyfilabs.com/project-ideas/design-and-fabrication-of-automated-portable-hammering-machine>
6. David H. Myaszak, Mechanisms and machine analysis – 4th edition.
7. [www. Hotelkishanpalaceheritage.com](http://www.Hotelkishanpalaceheritage.com).
8. library.atmiya.net, <http://library.atmiya.net:8080/dspace/bitstream/handle/123456789/4332/PDF%20%20REPORT%20AUTOMATC%20PORTABLE%20HAMMERING%20MACHINE%20111.pdf?sequence=1&isAllowed=y>
9. www.scribd.com <https://www.scribd.com/presentation/264515251/Power-Hammer-Presentation>
10. www.thefabricator.com <https://www.thefabricator.com/thefabricator/article/shopmanagement/fabricators-and-their-power-hammers>
11. Machine design book RS khurmi & JK gupta for calculation.