



Design and Construction of an Automatic Drainage Cleaner

Submitted by:

**Mehadi Hasan
Md. Shohiduzzaman
Md. Ashraful Alam
Md. Nazmul
Shahin Alam**

Supervised by:

**Niloy Sarkar
Lecturer
Department of Mechanical Engineering (ME)
Sonargaon University**

**Department of Mechanical Engineering
Sonargaon University, Dhaka**

February 2020

Design and Construction of an Automatic Drainage Cleaner

A Project

Submitted to

Sonargaon University, Dhaka

In Partial Fulfillment of the Requirements for the Degree of
B.Sc. in Mechanical Engineering

By

Mehadi Hasan

BME: 1602009359, Session: 2016-2017

Md. Shohiduzzaman

BME: 1602009244, Session: 2016-2017

Md. Ashraful Alam

BME: 1602009293, Session: 2016-2017

Md. Nazmul

BME: 1602009355, Session: 2016-2017

Shahin Alam

BME: 1602009152, Session: 2016-2017

**Department of Mechanical Engineering
Sonargaon University, Dhaka**

February 2020

Design and Construction of an Automatic Drainage Cleaner

Submitted by:

Mehadi Hasan

Md. Shohiduzzaman

Md. Ashraful Alam

Md. Nazmul

Shahin Alam

Approved as to style and contents by

Niloy Sarkar

Project Supervisor

February 2020

ACKNOWLEDGEMENT

The successful completion of any task would be incomplete without mentioning the people who made it possible with constant guidance and encouragement leading to success. Guidance and deadlines play a very important role in the successful completion of the project on time. The gratitude of the project work conveyed to Md Mostofa Hossain honourable Department head of Mechanical Engineering, for constantly monitoring the development of the project and setting up of precise deadlines. We are grateful to my project Supervisor Niloy Sarkar, Lecturer, Department of Mechanical Engineering, for his inspiration, support, scholastic guidance, valuable suggestion, constructive criticisms, hearted cooperation and motivation extended for my project work. It would have been quite impossible to carry out this work and give it a final shape without his advice and sympathetic encouragement.

The author would like to express his heartfelt respect to all the respected teachers of the Department of Mechanical Engineering, Sonargaon University for their encouragement and valuable advice throughout the study.

The author is thankful to all the staff of the Sonargaon University for their help, cooperation and friendly behavior during the period of the study.

Finally, the author expresses his heartfelt gratitude to his beloved parents, brothers and sisters for their never-ending inspiration, cooperation, financial help and continuous blessing that opened the gate and paved the way to higher study.

Authors

ABSTRACT

In this thesis, the proposal concept is to replace the manual work in drainage cleaning by an automated system. Nowadays even though automation plays a very important role in all industrial applications, the proper disposal of sewage from industries and commercials are still a challenging task. The drainage cleaning system is proposed to overcome real-time problems. With the continuous expansion of industries, the problems of sewage water must be urgently solved to minimize the increasing sewage problems from industries that affect the surrounding environment. The solid waste produced from the industries is very harmful to humans and to the environment. We know that water has great importance in human being life, the water flow in a drain full of wastes like polythene, bottles etc. The drains get blocked due to these wastes in water. Now a day's even through mechanical machine plays a vital role in all industrial applications in the proper disposal of sewage from industries and commercials are still a challenging task. Drainage is using for the disposal and unfortunately sometimes there may be loss of human life while cleaning the blockage in the drainages. The government also spends too much money to clean the drainages. In order to overcome the problems in manual drain cleaning, we are implementing to clean and control the drainage level. We designed our project to use this inefficient way to control the disposal of wastages and with regular filtration of wastages. The process starts collecting the sewage wastes by using the arm and it throws back the waste into the bin fixed in the machine at the bottom. An arm is used to lift the sewage and in turn, a bucket is used to collect them. The set-up runs even in sewage area with water (limited to a particular amount) so that the wastages which float on the water surface also gets collected. The garbage which affects the drainage is also picked up and removed. This system has limited human intervention in the cleaning process and in turn, reduces the spreading of diseases to mankind.

LIST OF CONTENTS

CHAPTER	TITLE	PAGE NO.
	ACKNOWLEDGEMENT	i
	ABSTRACT	ii
	LIST OF CONTENTS	iii-iv
	LIST OF TABLE	v
	LIST OF FIGURES	vi
	NOMENCLATURE	vii
I	INTRODUCTION	1-2
	1.1 Background	1
	1.2 Objectives	2
II	LITERATURE REVIEW	3-6
	2.1 Review	3
	2.2 Advantages	5
	2.3 Disadvantages	6
III	DESIGN AND EXPERIMENTAL SETUP	7-26
	3.1 Design	7
	3.2 Setup	9
	3.3 Instruments	10
	3.3.1 Angle bar	11
	3.3.2 Shaft	12
	3.3.3 Bearing	13
	3.3.4 Sprocket	16
	3.3.5 Chain	17
	3.3.6 Bearing Casing	18
	3.3.7 Nut & Bolt	18
	3.3.8 Collecting Jaw	19
	3.3.9 GI Net	20
	3.3.10 PVC Board	21

LIST OF CONTENTS

CHAPTER	TITLE	PAGE NO.
	3.3.11 Dust Box	21
	3.3.12 DC Gear Motor	22
	3.3.13 Battery	23
	3.3.14 Power Supply	25
IV	EXPERIMENTAL RESULTS AND DISCUSSION	27-29
	4.1 Calculation	27
	4.2 Result	28
	4.3 Discussion	29
V	CONCLUSION AND RECOMMENDATION	30
	FUTURE SCOPE	31
	REFERENCES	32

LIST OF TABLE

TABLE	TITLE	PAGE NO
3.1	Used Instruments List	10
3.2	Specification of Ball bearing	15
3.3	Specification of Motor	22
3.4	Specifications of Battery	23

LIST OF FIGURES

FIGURE	TITLE	PAGE NO.
3.1.1	SolidWorks Setup	7
3.1.2	SolidWorks Setup	8
3.1.3	SolidWorks Setup	8
3.1.4	SolidWorks Setup	8
3.2	Experimental Setup	9
3.3.1	Angle Bar	11
3.3.2	Angle Bar	11
3.4.1	Shaft	12
3.4.2	Shaft	12
3.4.3	Shaft	13
3.5	Ball bearing	14
3.6	Different dimension of a Ball bearing	15
3.7	Sprocket	16
3.8	Chain	17
3.9	Bearing Casing	18
3.10	Nut & Bolt	18
3.11.1	Collecting Jaw	19
3.11.2	Collecting Jaw	19
3.11.3	Collecting Jaw	20
3.12.1	GI Net	20
3.12.2	GI Net	20
3.13	PVC Board	21
3.14	Dust Box	21
3.15	DC Gear Motor	22
3.16.1	DC Battery	24
3.16.2	DC Battery	24
3.17	Power Supply	26
4.1	Force Diagram	27
4.2	Roller Diagram	27

NOMENCLATURE

3D = Three Dimensions.

GI = Galvanized Iron

AC = Alternating Current.

ARM = Is a Microprocessor.

AVR = Alf & Vegard's RISC Processor.

cm = Centimeter.

JTAG = Joint Test Action Group.

LAN = Local Area Network.

mm = Millimeter

MS = Mild Steel

PVC = Polymerization of Vinyl Chloride or Polyvinyl Chloride.

ADCS= Automatic Drainage Cleaning System.

CHAPTER I

INTRODUCTION

1.1 Background

The Drainage water cleaning system is used to clean wastes from the water like polythene, bottles etc. present in water. This can be used to overcome the problem of filtration of wastes from water and it saves them time and cost that spend on cleaning the drainage. As the industry setup increase in the environment the water coming from industries are full of wastes like polythene, bottles, and other materials and that water mix with the other water that is used by people and we know that that water is not good for the health of people. Therefore, to overcome these problems we can filter the water drainage water before it mixes with other water. This type of filtration of water is called primary filtration. In this project we use DC or AC motor to run the system when the power supply is available & the Equipment we used are motor, chain, driver, bucket, frame, wheel, sprocket gear, solid shaft etc. Water is a basic necessity of human and all living beings. There is plenty of water on earth that is not suitable for human use. The impurities present in water can cause hazardous diseases. Wastewater is defined as the flow of used water from homes, business industries, commercial activities and institutions which are subjected to the treatment plants by a carefully designed and engineered network of pipes. The biggest impact of cleaning the chemical wastes can cause respiratory diseases and it plays a challenging issue for the municipality officers. Water damage is classified into three types of contaminated water. They are clean water, grey water and black water. Clean water is from a broken water supply line or leaking faucet. If not treated quickly, this water can turn into black water or grey water, depending on the length of time, temperature, and contact with surrounding contaminants. Gray water is contaminated water that causes discomfort or illness. It includes washing machine overflow; toilet overflow with some urine, and dishwasher overflow. Blackwater is grossly contaminated and could cause severe illness or death if ingested and avoided such as flooding from rivers or streams, water from beyond the toilet trap, water from the toilet bowl, or standing water that has begun to support microbial growth.

A drainage ditch is a narrow channel that is dug at the side of a road or field to carry away the water. Nowadays, even though automation plays a vital role in all industrial applications in the proper disposal of sewage from industries and sewage cleaning is still a challenging task. Drainage pipes are used for the disposal of sewage and unfortunately, sometimes there may be loss of human life while cleaning the blockages in the drainage pipes. The municipality workers are only responsible to ensure that the sewage is clean or not. Though they clean the ditches at the side of buildings, they can't clean in very wide sewages. The municipality workers need to get down into the sewage sludge to clean the wide sewage. It affects their health badly and also causes skin allergies. With the continued expansion of industries, the problem of sewage water must be urgently resolved due to the increasing sewage problems from industries to the surrounding environment. To overcome this problem and to save human life this design of sewage cleaning machine is proposed. In the

proposal concept, the manual work in drainage cleaning is replaced by an automated system. The existing system is designed in order to reduce the load of workers and to make clean in Bangladesh.

1.2 Objectives

The main objective of the thesis is to design, fabrication and assess the performance:

- To avoid the blockage of drainage line cause by solid waste.
- To replace the manual work in drainage cleaning by an automated system.
- To reduce the environment pollution.
- To avoid the various disease to the workers.

CHAPTER II

LITERATURE REVIEW

2.1 Review

Ganesh U L, et.al. [1] showed the usage of mechanical drainage cleaner to replace the manual work required for drainage cleaning system. Drainage pipes are very dirty. Sometimes it is harmful for human life while it is need for cleaning drainage system. To overcome this problem, they implemented a mechanical semi-automatic drainage water cleaner and so the water flow is efficient because of regular filtration of wastages with the help of that project. Different kinds of environment hazards reduced with the help of Drainage system machine.

Dr .k.kumaresan [2] explained manual work converted to automated system. Drainage pipe using for disposal and it may be loss for human life while cleaning the blockage in the drainage pipes. To overcome this problem they implemented “Automatic Sewage Cleaning System”. They designed their project different way clearance of gaseous substance are treated separately so the flow of water efficiently. This project may be developed with the full utilization of men, machines, and materials and money. They made their project economical and efficient with the available resources. They used automation technology related with his application of mechanical, electronics, computer based systems to operate and control production.

Nitin Sall, et.al. [3] explained flow of used water from homes, business industries, commercial activities is called waste water. 200 and 500 liters wastage water are generated each person every day. So using waste water technology that removes, rather than destroys, a pollutant in a drainage system.

Gregor Burger, et.al. [4] described the concept and software design of an innovative general purpose platform for network based model development and look at some of crucial computational design issues. They developed the improvement in the design of very fast, easy to use, easy to integrate and extensible general purpose simulator platform. It was running up to 40 times faster than its MATLAB based predecessor and allowing it to be flexibly applied. They included features such as the hot-start mechanism and the extension interfaces have proven to be extremely useful when linking city drain 3 as a sub-model into larger software project.

NDUBUISI C. Daniels, et.al. [5] Showed the Drainage system cleaner machine used to remove garbage and sewage automatically which helped to protect the environment from different kinds of environmental hazards. The drainage system cleaner has three major parts which are the Propeller, the Cleaner and the Pan all makes up for its effective functioning.

Prabhushankar N et al. [6] designed a machine, which used reciprocating pump as the main component instead of centrifugal pump for dewatering of drainages. As centrifugal pump was costlier and less effective in complete removal of suspended and heavy solids. They used pneumatic and spring system with reciprocating cylinder. There was use of pneumatic cylinder, which used power of compressed air to produce linear motion with reciprocation. One component of pneumatic drainage system was spring return pneumatic cylinder. One drawback with it was less efficiency, as part of force produced by cylinder was lost as it tried to push against the spring.

Vetrivel S et al. [7] proposed a system to build a sewer robot which was capable of cleaning the blocks in sewer pipe of diameter from 80-100mm without employing humans. In that caterpillar type wheel system were engaged to increase the cleaning while vertical movement. That whole system was developed in low cost & inspection of pipe could be easily done with the help of “Sewer Robot using concept of Sensor Locomotives”. That whole system worked on instruction. Four bar chain mechanism were used so that it could expand and shrunk their wheel suspensions, together its own movement. By using some sensors and processors together along with locomotive, they could easily do inspection & cleaning action where the human hand could not reach easily.

They worked on deplete squander water cleaner machine planned and made by utilizing gear changing and shaft coupling it comprises fundamentally dc equipped engine shaft squander expulsion plate receptacle course sprocket and chain construction material are effortlessly available create work development and mentainance siple to build [8].

Elangovan K., et.al. [16] reviewed about drainage cleaning to replace manual work to automated system because manually cleaning system it is harmful for human life and cleaning time, is more so to overcome this problem they implemented a design “Automatic drainage water pump monitoring and control system using PLC and

SCADA”. PLC and SCADA were designed. In this project to use efficient way to control the disposal of wastage regularly, treatment of disposal in different way toxic and non-toxic gases. PLC controller from Siemens was used in the treatment system of drainage wastewater control by the stepper motor, compressor, gas exhauster, pressure valve and the liquid level, flow and other analog variables to achieve automatic control of sewage waste water treatment.

The device is place across a drain so that only water flows through the lower basement. Floating waste like bottles, plastic cans, covers...etc. is lifted by lifters which are connected to the chain. The chain revolves with the sprocket wheel which is driven by the motor. The energy provided to the motor is electrical energy. When motor runs the chain starts to circulate making the lifter to lift up. The wastage material are lifted by lifter teeth and stored in storage or collecting bin. Once the collecting bin is full, the waste materials are removed from the bin. Further they are replaced in various size of our convenience. There by it works as the flow of water, it could be further scoped as to create a water flow in stagnant water so that the waste are made to flow in the path to our conveyer.

2.2 Advantages:

- It is reliable and portable.
- It cleans continuously.
- It is time-saving.
- Development materials are regularly locally applicable.
- No need to purchase a special machine.
- It is easy to manufacture.
- It is easy to operate.
- Skill Worker not required driving the system.
- It can be efficiently used.
- Maintenance cost is very low.
- Its machine parts are easily available.
- It can be operated with the unskilled employee.
- Environment-friendly system.

2.3 Disadvantages:

- Rust.
- Small vibration occurred due to wire brush wheel attachment.
- It is able to clean solid waste only.
- Cannot withstand higher loads.
- Sometimes the slurry present into the drainage water could jam the chain drive while dipping into the water.

CHAPTER III

DESIGN AND EXPERIMENTAL SETUP

3.1 Design

SOLIDWORKS is a very productive 3D CAD software tool, with its integrated analytical tools and design automation to help stimulate physical behaviours such as kinematics, dynamics, stress, deflection, vibration, temperatures or fluid flow to suit all types of design.

This design was completed by "SolidWorks 2016" software.

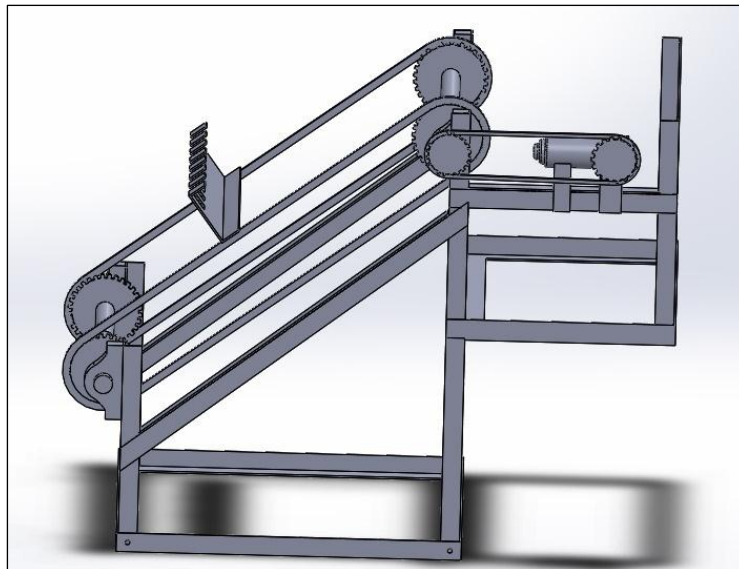

Figure 3.1.1: SolidWorks Setup

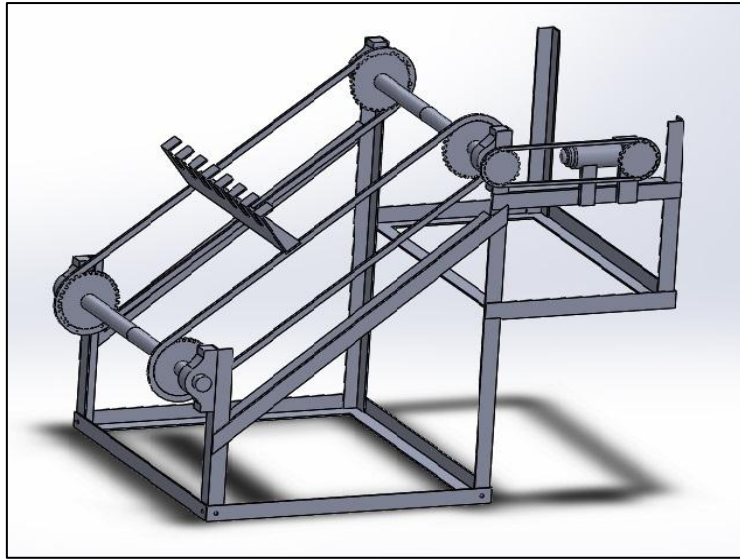

Figure 3.1.2: SolidWorks Setup

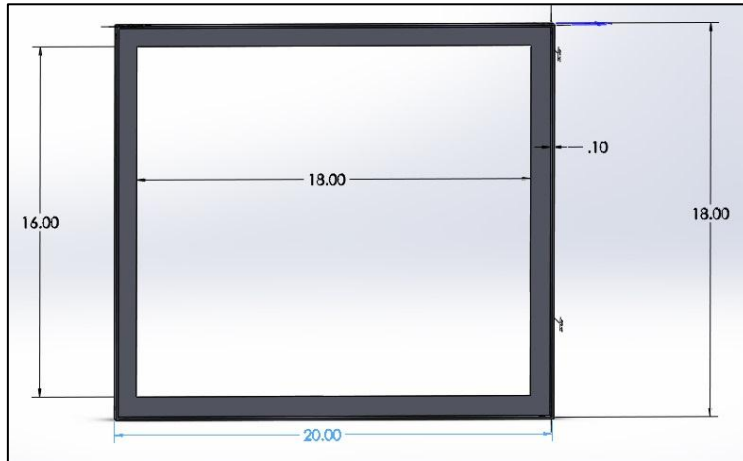

Figure 3.1.3: SolidWorks Setup

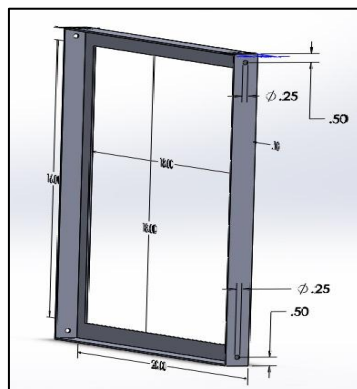

Figure 3.1.4: SolidWorks Setup

3.2 Setup

The Frame of machine means of experimental setup has made of Mild Steel (1 inch \times 1 inch) angle bar which is comparatively lighter in weight and strong than (2 inch \times 2 inch) square bar. The frame has kept 2 inch height from the ground as bed/ base. The total length of the frame is 32 inch. The width of the frame has kept 20 inch as well as. The Height, Length and Width has kept those dimensions which avoid vibration and convenient to operate the machine easily.

Firstly, Angle bar used in various dimension like as 24 inch two pieces, 20 inch four pieces, 18 inch two pieces, 10 inch two pieces, 11 inch two pieces, 12 inch two pieces all of angular bar used in mild steel.

Secondly, here use 30mm diameter shaft and length 24 inch one piece, 27 inch one piece.

Thirdly, Chain Sprockets are used to convert torque one shaft to another shaft. Chain Core width 10mm and length 20 mm. Sprocket teeth are used in 27.

Finally, to run this machine by used of DC Gear Motor and the power source of Motor is Battery (12V). In this arrangement Welding, drilling operations had done.



Figure 3.2: Experimental Setup

3.3 Instruments:

Table 3.1: Used Instruments List

S.N.	Name & Description	Qty.
1.	Angle bar (1" to 1") length 24"	2
2.	Angle bar (1" to 1") length 20	4
3.	Angle bar (1" to 1") length 18"	2
4.	Angle bar (1" to 1") length 10"	2
5.	Angle bar (1" to 1") length 11"	2
6.	Angle bar (1" to 1") length 12"	2
7.	Shaft (30mm) diameter, length 24"	1
8.	Shaft (30mm) diameter, length 27"	1
9.	Sprocket (27 teeth), diameter 12cm	4
10.	Sprocket (14 teeth), diameter 5cm	2
11.	Ball Bearing (6205)	4
12.	Bearing Casing	4
13.	Fastening (Bolt, Nut, Screw etc. (6mm-45p, 12mm-8p, 3mm-4p)	-
14.	Chain	144"
15.	Bearing Bush (Bore 30mm)	4
16.	MS Sheet (length 18", width 7", thickness 2mm)	1
17.	GI Net (24" * 20")	1
18.	PVC Sheet (48" * 24")	1
19.	DC Gear Motor (12V)	1
20.	Battery (12V, 7.4Ah)	1
21.	Power Supply (14V,3A)	1
22.	Switch (20A)	1
23.	2 Pin Plug	1

3.3.1 Angle bar

An iron or a steel structural bar that has an L-shaped cross section.

Angle bar here we used in various dimension like as 24" (inch) two pieces, 20" (inch) four pieces, 18" (inch) two pieces, 10" (inch) two pieces, 11" (inch) pieces, 12" (inch) two pieces. All of the angular bar are used in mild steel. The thickness of the mild steel is 4mm.

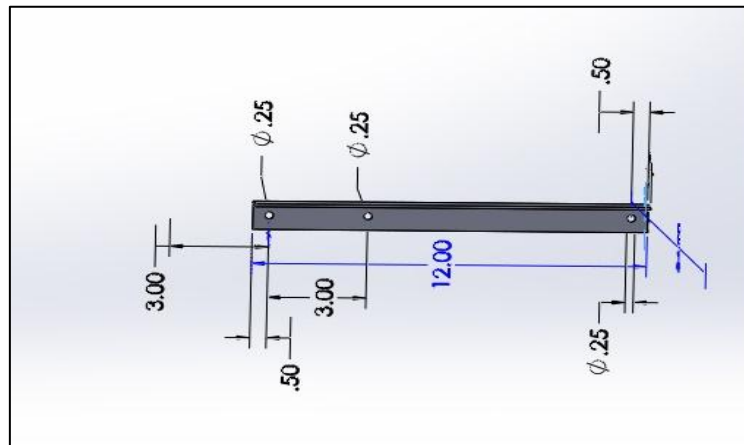

Figure 3.3.1: Angle bar

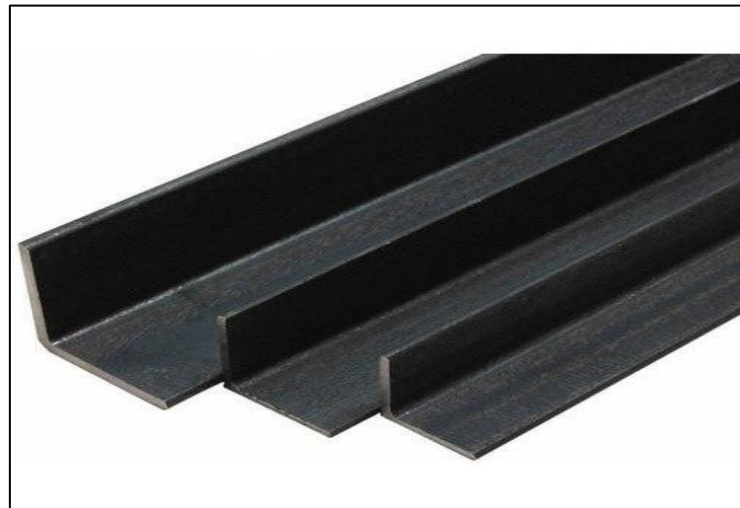

Figure 3.3.2: Angle bar

3.3.2 Shaft

A shaft is a rotating machine element, usually circular in cross section, which is used to transmit power from one part to another, or from a machine, which produces power to a machine, which absorbs power. The various members such as pulleys and gears are mounted on it.

Here we use 30 mm diameter shaft and length 24" (inch) one piece, 27" (inch) one piece. Here use solid shaft. This shaft is convert torque motor to shaft and one shaft to another shaft by the use of chain sprocket.

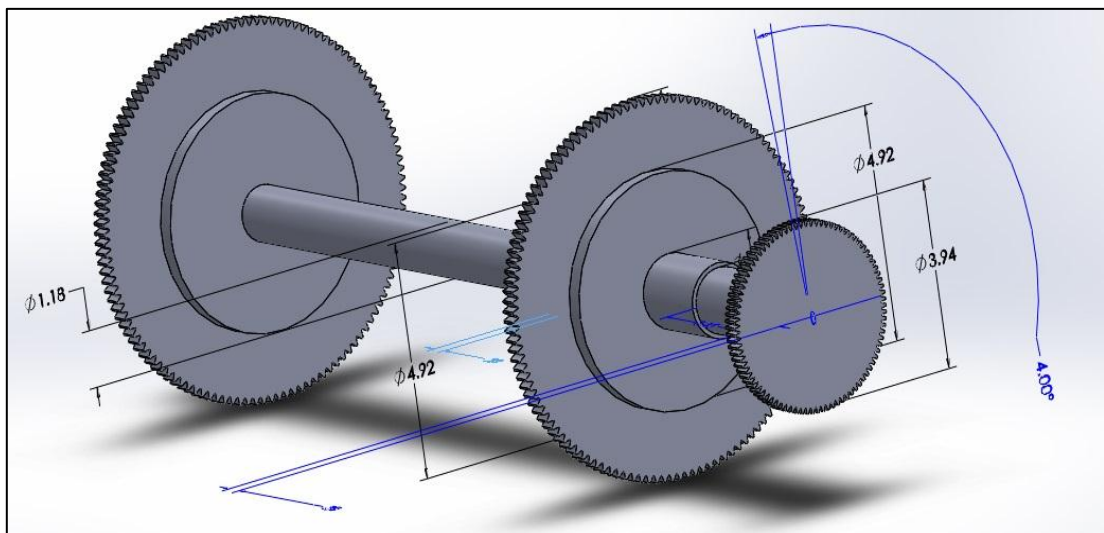

Figure 3.4.1: Shaft

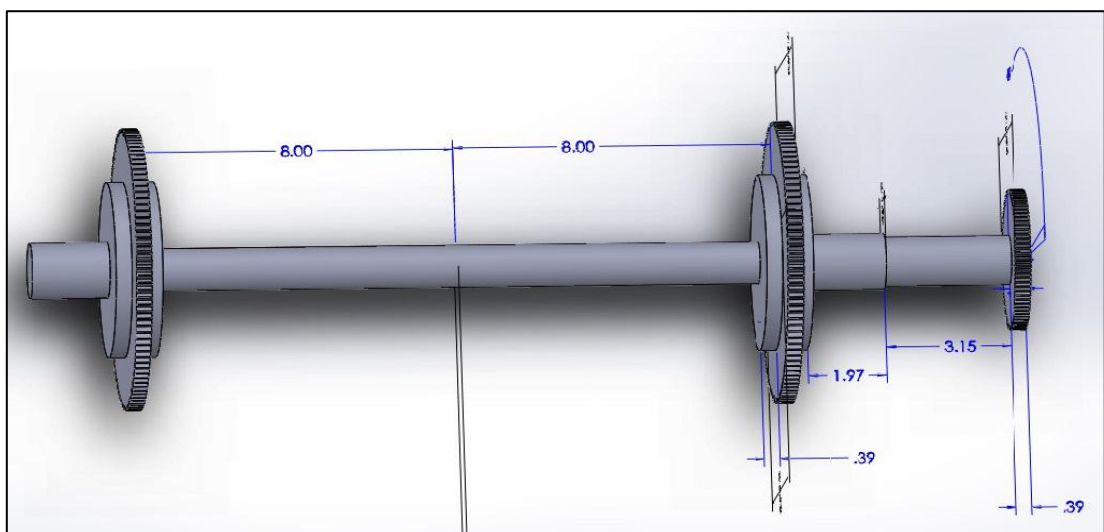

Figure 3.4.2: Shaft



Figure 3.4.3: Shaft

3.3.3 Bearing (Ball bearing)

A ball bearing is a type of rolling-element bearing that uses balls to maintain the separation between the bearing races.

The purpose of a ball bearing is to reduce rotational friction and support and axial loads. It achieves this by using at least three races to contain the balls and transmit the loads through the balls. In most applications, one race is stationary and the other is attached to the rotating assembly (e.g., a hub or shaft). As one of the bearing races rotates, it causes the balls to rotate as well. Because the balls are rolling, they have a much lower friction than if two flat surfaces were sliding against each other.

Ball bearings tend to have lower load capacity for their size than other kinds of rolling-element bearings due to the smaller contact area between the balls and races. However, they can tolerate some misalignment of the inner and outer races.

Here use four pieces Ball Bearing. It's bearing number 6205.

Deep Groove Ball Bearings 6205 – 25 X 52 X 15 mm Description:

The 6205 is a 25 mm Ball Bearing that can be used in many rotary and factory automation applications. The 6205 Deep Groove Ball Bearings is an open style bearing. The 6205Z ball bearing is a single row raceway and single shielded. The 6205 25 mm Ball Bearing Inner Dimension 25mm X Outer Dimension 52mm X Width 15mm is an open style ball bearing designed for high rotational speeds and high dynamic loads.

First number represents in the given bearing nos. 6202, 6203,.... Type of bearing (in this case for 6- Deep Groove Ball Bearing (Single row) and the second number represents the Bearing series, which reflects the robustness of the bearing.(in this case for 2 - light series & for 3- medium series and third and fourth number represents the bore diameter of the bearing. Multiplying with 5 gives the bore diameter (in mm) for numbers 04 & above.

For eg: The bore diameter of 6205 bearing = $05 \times 5 = 25\text{mm}$.

For 00 to 03 the standardized bore diameters are:

00— 10mm

01 —12mm

02— 15mm

03— 17mm

For eg: The bore dia of 6202 bearing = 15mm



Figure 3.5: Ball bearing

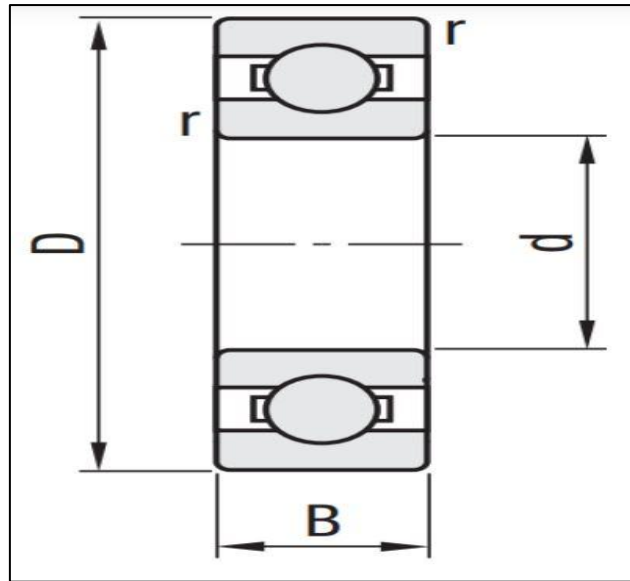

Figure 3.6: Different dimension of a Ball bearing.

Table 3.2: Specification of Ball Bearing

Below table given the specification of 6205 Bearing:

Universal	6205
Type	Ball
Inner/Outer Ring Material	Steel
Precision	Grade 0
Inner Dimension d(\varnothing)	25 mm
Outer Dimension D(\varnothing)	52 mm
Width B (or T)(mm)	15 mm
Retainer Type	Punching
Load Direction	Radial
Specifications/Environment	Standard
Number of Raceway Ring Rows	Single Track
Size Standards	Metric Series

3.3.4 Sprocket

A sprocket or sprocket-wheel is a profiled wheel with teeth, or cogs, that mesh with a chain, track or other perforated or indented material. The name 'sprocket' applies generally to any wheel upon which radial projections engage a chain passing over it. It is distinguished from a gear in that sprockets are never meshed together directly, and differs from a pulley in that sprockets have teeth and pulleys are smooth. Sprockets are used in bicycles, motorcycles, cars, tracked vehicles, and other machinery either to transmit rotary motion between two shafts where gears are unsuitable or to impart linear motion to a track, tape etc. Perhaps the most common form of sprocket may be found in the bicycle, in which the pedal shaft carries a large sprocket-wheel, which drives a chain, which, in turn, drives a small sprocket on the axle of the rear wheel. Early automobiles were also largely driven by sprocket and chain mechanism, a practice largely copied from bicycles.

Here use total six pieces sprocket. Where Sprocket (27 teeth), diameter 12cm use 4 pieces and Sprocket (14 teeth), diameter 5cm use 2 pieces, 12 cm diameter sprocket are used to convert torque one shaft to another shaft and 5 cm diameter sprocket are used to convert torque motor to shaft.

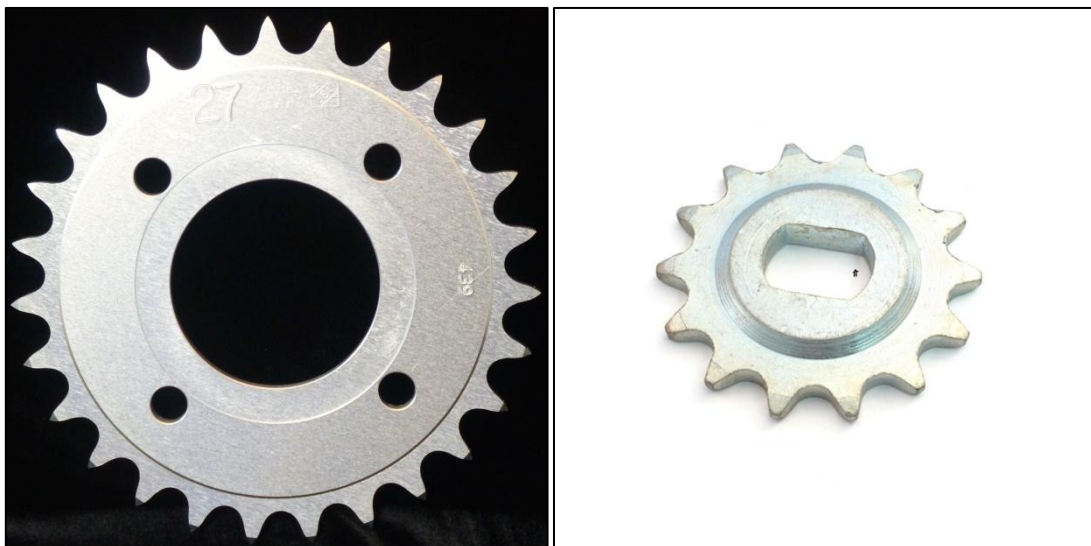

Figure 3.7: Sprocket

3.3.5 Chain

Most often, the power is conveyed by a roller chain known as the drive chain or transmission chain, passing over a sprocket gear, with the teeth of the gear meshing with the holes in the links of the chain. The gear is turned, and this pulls the chain putting mechanical force into the system. Sometimes the power is output by simply rotating the chain, which can be used to lift or drag objects. In other situations, a second gear is placed and the power is recovered by attaching shafts or hubs to this gear. Though drive chains are often simple oval loops, they can also go around corners by placing more than two gears along the chain; gears that do not put power into the system or transmit it out are generally known as idler wheel. By varying the diameter of the input and output gears with respect to each other, the gear ratio can be altered. For example, when the bicycle pedals gear rotate once, it causes the gear that drives the wheels to rotate more than one revolution. For the lifting of the sewages, we require conveyor belt like construction for such purpose we used chains of the motorcycles. A chain conveyor system is a type of conveyor system, which is used for moving material through production lines. The chain driven conveyor the belt is bolted to a series of cross-members, the ends of which connects to chains running down each side of the conveyor. The chains connect to the motor via a sprocket. The main benefit that the chain driven belt conveyor provides, pure power, without slipping. Chain are used to convert torque one shaft to another shaft and motor to shaft. Chain Core width 10 mm and length 20 mm. Total length of th chain is 144" (inch).



Figure 3.8: Chain

3.3.6 Bearing Casing

Here uses four pieces Bearing casing (6205). Bearing casing material use in Mild steel. Bearing casing mainly use to hold the shaft with structure.



Figure 3.9: Bearing casing

3.3.7 Nut & Bolt

Nut Bolts are used to attach the various part of this machine. Various diameters and various lengths Nut Bolt use this machine. Such as 6 mm-45p, 12 mm-8p, 3 mm-4p.



Figure 3.10: Nut and Bolt

3.3.8 Collecting Jaw (MS Sheet)

MS Sheet are used to collect floating waste and remove this waste into box and this sheet are attach with chain and move continuously. MS Sheet (length 18" (inch), width 7" (inch), the thickness of the mild steel is 2mm).

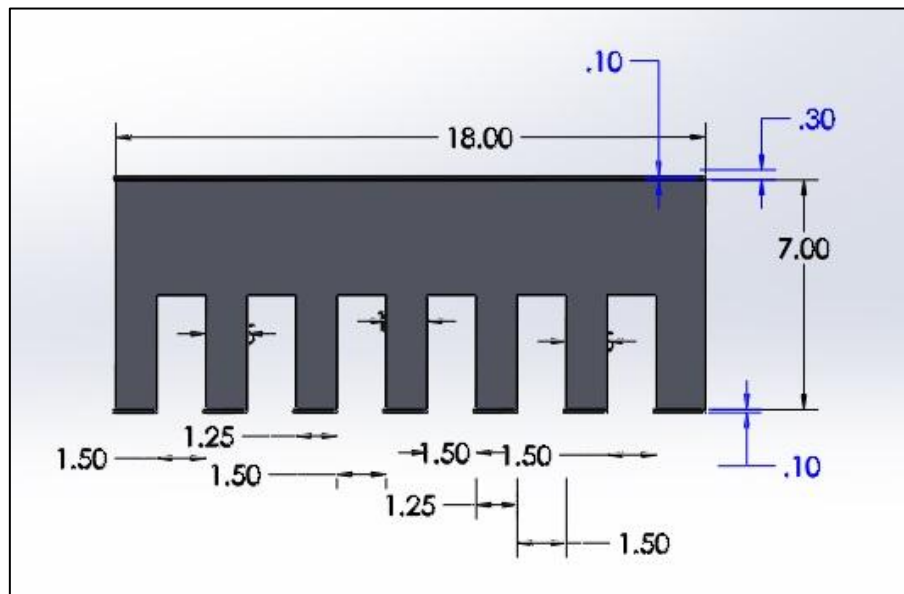

Figure 3.11.1: Collecting Jaw (MS Sheet)

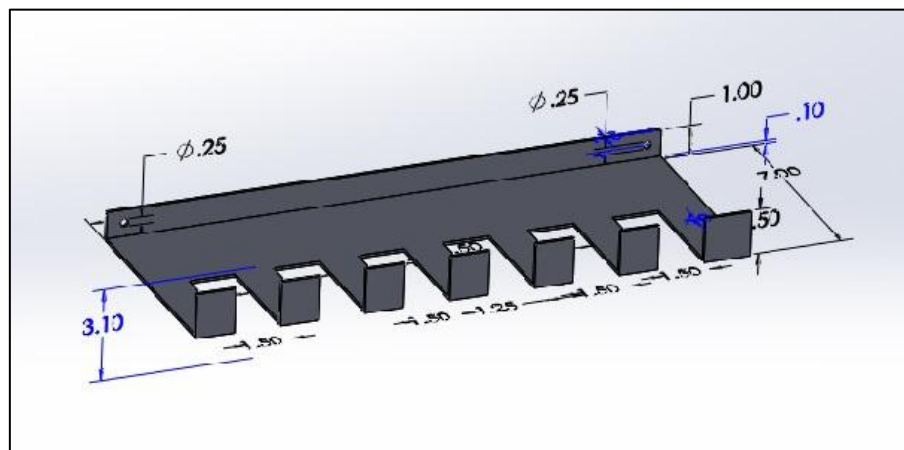

Figure 3.11.2: Collecting Jaw (MS Sheet)



Figure 3.11.3: Collecting Jaw (MS Sheet)

3.3.9 GI Net

GI Net are used to flow of water easily but resistance for floating waste like as plastic, bag, bottle, cloth etc. its size is [(24"(inch) X 20"(inch)].

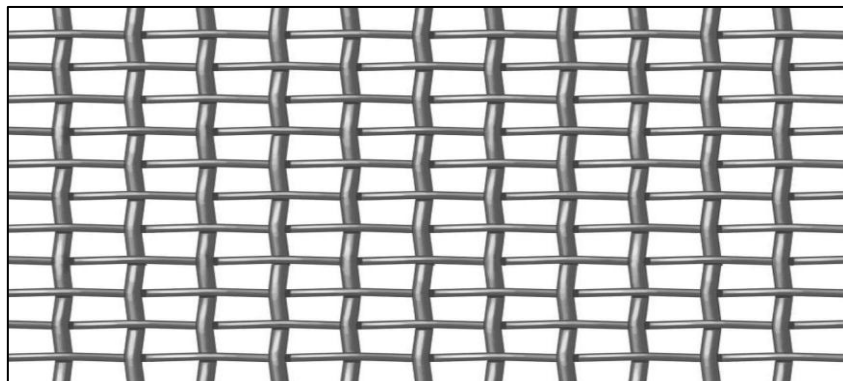

Figure 3.12.1: GI Net



Figure 3.12.2: GI Net

3.3.10 PVC Board

PVC Board is used to make dust collector box. Board size (48" * 24")



Figure 3.13: PVC Board

3.3.11 Dust Box

Dust box are used to hold dust which are collected from drain by MS Sheet. Box length 20" (inch), width 11" (inch) and height 12" (inch).



Figure 3.14: Dust Box

3.3.12 DC Gear Motor

For the proper running of the model, we require high power motor with sufficient amount of torque. Therefore, it can be lift an amount of sewages such as polythene, bottles and other sewages, which is comes in the contact of lifter. The power and torque of the DC motor is depends on its RPM. If any motor have less revolution then the capacity of the motor is high. For the high weight liften we use 12 volt DC gear motor having near about 150 rpm, such type of motor can carry 15 kg of weight.

The shaft of the motor is centrally mounted.

Table 3.3: Specification of Motor

Supply Voltage	12 volt DC
Power	1000N-m torque
Motor Revolution	150 PRM
Motor Weight	2 KG

Given below the figure of motor:



Figure 3.15: DC Gear Motor

3.3.13 Battery (12V)

A rechargeable battery, storage battery, secondary cell, or accumulator is a type of electrical battery which can be charged, discharged into a load, and recharged many times, as opposed to a disposable or primary battery, which is supplied fully charged and discarded after use. It is composed of one or more electrochemical cells. The term “accumulator” is used as it accumulates and stores energy through a reversible electrochemical reaction. Rechargeable batteries are produced in many different shapes and sizes, ranging from button cells to megawatt systems connected to stabilize an electrical distribution network. Several different combinations of electrode materials and electrolytes are used, including lead–acid, nickel–cadmium (NiCd), nickel–metal hydride (NiMH), lithium-ion (Li-ion), and lithium-ion polymer(Li-ion polymer).

Table 3.4: Specifications of Battery

Given below the Specifications of Battery:

Name of the Manufacturer	High Power
Nominal battery voltage	12 Volt DC
Capacity	12V7.5AH/20HR
Standard dimension	151mm x 65mm x 97.5mm (L x W x H with terminal)
Charging temperature range	-15°C to 50°C.
Discharging temperature range	-20°C to 60°C.
Battery weight	2.2 Kg
Life Time	5 Years at -20°C



Figure 3.16.1: DC Battery



Figure 3.16.2: DC Battery

3.3.14 Power Supply

Simple 12 volt battery charger circuit diagram designed by using few easily available components, and this circuit is suitable for different types of batteries needs 12 Volt. We can use this circuit to charge 12V SLA battery or 12V Gel cell battery and so on. This circuit is designed to provide charging current upto 3 amps and this circuit don,t reverse polarity protection or over current protection so kindly test this circuit before stepping into battery charging.

This simple 12 volt battery charger circuit diagram gives us a outline design for the general battery charger and we can add additional features to this circuit like reverse polarity protection by placing a diode at the output.(diode anode to output positive supply and diode cathode as output positive terminal) and over current protection setup using transistors.

This Power supply are used to charge the rechargeable battery, it is made by Step-down Transformer (220/12*2) V AC, diode and capacitor.

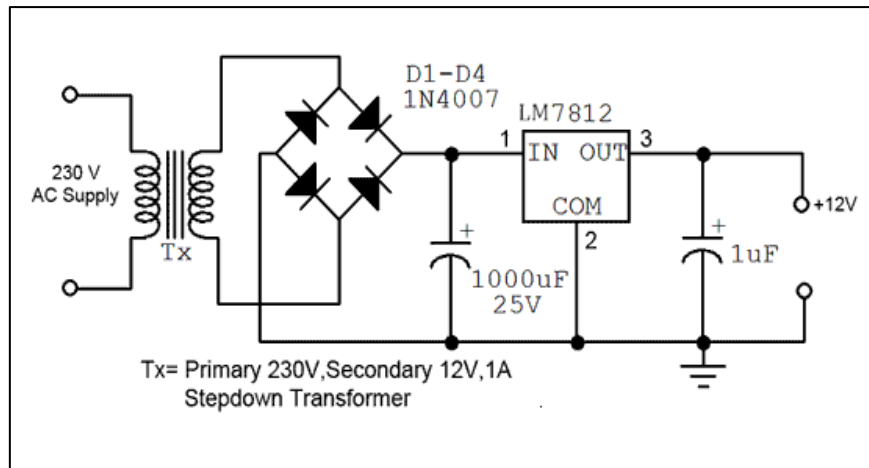

Figure 3.17: Power Supply

CHAPTER IV

EXPERIMENTAL RESULTS AND DISCUSSION

4.1 Calculation

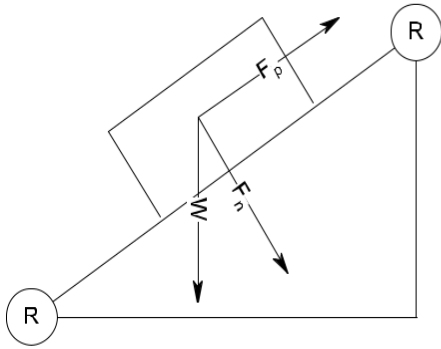

Figure 4.1: Force Diagram

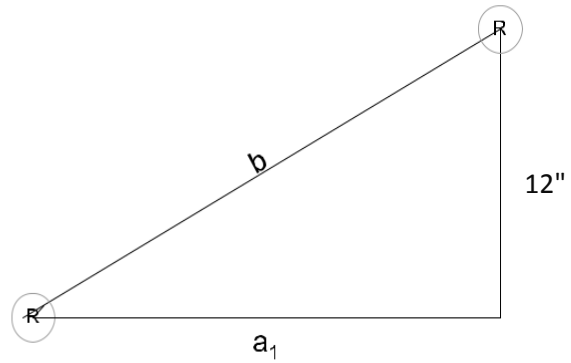

Figure 4.2: Roller Diagram

(a) Mass to be lifted = 4 kg and

(b) Lifting unit weight = 3 kg

Thus,

$$\begin{aligned} \text{Total mass} &= (4+3) \text{ kg} \\ &= 7 \text{ kg} \end{aligned}$$

Vertical distance between two shaft = 12 inch.

$a_1 = 18$ inch & Vertical distance = 12 inch

$$b = \sqrt{18^2 + 12^2} = 21.6 \text{ inch}$$

Now from figure,

$$\tan\alpha = \frac{12 \text{ inch}}{a_1} \text{ and } \cos\alpha = \frac{18}{b}$$

So, $\alpha = 34^\circ$

$$1) \text{ Pulling forces } (F_p) = \text{mass} \times 9.81 \times \sin\alpha$$

$$\text{Or } F_p = 7 \times 9.81 \times \sin 34^\circ = 38.4 \text{ N}$$

- 2) Distance between two pulleys (rollers) = 21.6 inch = 0.55 m
- 3) Linear Velocity, $v = \text{distance}/\text{time} = (0.55 \times 2)/8 = 0.137 \text{ m/s}$
- 4) Acceleration, $f = \frac{v}{t} = \frac{0.137}{8} = 0.0172 \text{ m/s}^2$
- 5) Resisting force, $F_r = \text{mass} \times \text{acceleration}$
$$= 7 \times 0.0172$$
$$= 0.1204 \text{ N}$$
- 6) Torque required, $T = F_p \times \text{distance} = 38.4 \times 0.55 = 21.12 \text{ N-m}$
- 7) Power required to drive $P = \frac{2\pi NT}{60}$
$$= \frac{2\pi \times 150 \times 21.12}{60}$$
$$= 332 \text{ watt}$$

4.2 Result

Linear Velocity = 0.137 m/s

Acceleration = 0.0172 m/s²

Resisting force = 0.1204 N

Torque required = 21.12 N-m

Power required to drive = 332 watt

4.3: Discussion

Now a day in the modern era, different products from different aspects are developed and developing day by day. By the combination of intellectuals and hardworking, an automatic drainage cleaning machine has built, which will play an important role in the clean at low-cost and less-time. While conducting the experiment the parameters considered are uniform flow rate of water, depth of the channel is 1feet and height of the channel is 3feet, rate of disposal of waste is uniform, lifter speed and motor speed is constant. Cost of the machine is economic and it requires only12-24 volts of current.

These cleaners are easy cheapest way to fix drainage problems. Easy to operate as no special skill is required. Reduction of labor-oriented method of cleaning, thus Up grading dignity of labors. Light weight and easily portable. Large amount of garbage will collect which can be re-manufacture able.

CHAPTER V

CONCLUSION AND RECOMMENDATION

This system is controlled by the motor, roller chain and sprocket, lifter and the collecting bin to achieve semi-automatic control of sewage waste water treatment. Drainage from industries is treated through this project to meet the national emission standards, with stable operation, low cost and good effect. Drainage wastewater control is treated by this method to irrigate plants, clean toilets, etc. The cleaner functioned move effectively during the heavier rains which had more volume of running water with garbage and high velocity. Automation is a technology concerned with his application of mechanical, electronic and computer based systems to operate and control production. This system is used To Operate Automatic Sewage Cleaning System. This project may be developed with the full utilization of men, machines, and materials and money. Also we have followed thoroughly the study of time motion and made our project economical and efficient with the available resources. This system was Designed, Fabricated successfully and also tested. It works satisfactorily. We hope that this will be done among the most versatile and interchangeable one even in future. Thus we can able to obtain Automatic Sewage Cleaning system.

To err is human, in spite of that this project, has been able to gain a lot of practical experience to the authors that will be beneficial for achieving the goal in future life as well as the mistake that has been made here will affect the next course of action.

This Project has carried out by applied the combinations of Mechanical, Computer Electrical and Electronics Technology. In Mechanical era there are numerous machine elements (i.e. Shaft, Chain, Pinion etc.) with metal infrastructure, Computer era used solid works, Electrical and Electronics era used numerous sensors, AC, DC motors, power supply etc.

FUTURE SCOPE

In future, this project can be improved to sort more categories of waste. In this system we can use advance conveyor system and conveyor material for increasing the efficiency of collection of garbage. We can use the solar panel for providing power to the boat instead of battery operation. To modify the size of boat according to its waste collecting capacity is increases. This project makes only for small lake by doing some modification in its size and capacity it can use in big lake and river like Ganga [9].

In future, this project can be made fully automated system by the use and application of automatic sensors and by the implementation of control algorithms. This system can be run fully automated by eliminating the idle time running by starting and stopping mechanism by use of proper sensors. Controlling and managing the wastes efficiently by use of appropriate handling devices.

References

- [1] Ganesh U L, et.al. "Semi-Automatic Drain For Sewage Water Treatment Of Floating Materials", International Journal of Research in Engineering and Technology, Vol No- 05, Jul-2016.
- [2] Dr .K.Kumaresan et.al., "Automatic Sewage Cleaning Equipment", International Conference on Explorations and Innovations in Engineering and Technology, 2016.
- [3] Nitin Sall, et.al., "Drain Waste Water Cleaner", Global Journal of Researches in Engineering: J General Engineering Vol No- 16, 2016.
- [4] Gregor Burger, et.al, "Designing and Implementing a Multi-Core Capable Integrated Urban Drainage Modelling Toolkit: Lessons from CityDrain3", Advances in Engineering Software 100, 2016.
- [5] NDUBUISI C. Daniels, "Drainage System Cleaner A Solution to Environmental Hazards", International Referred Journal of Engineering March 2014.
- [6] Tipayale Aman, Jadhav Kunal, Dashmukhe Sanket, Nisal Harshal and Naragude Yogesh, Smart drainage cleaning system, International Journal for Scientific Research & Development|,2017, Vol. 5, Issue 2, Pp. 2321-2613.
- [7] Ganesh U L, Vinod V Rampur, Semi-Automatic Drain for Sewage Water Treatment of Floating Materials, IJRET: International Journal of Research in Engineering and Technology, Issue 10, Vol. 4, Pp.2319-1163
- [8] International journal of science and technology management and research volume 2 issue 2 febraury 2017
- [9] Silaban, Zulfran, Romualdus Justin Harianja, Yoseva Sari Tondang, and Batu Mahadi Siregar. "Desain Model Toba Lake Trash Cleaners." In Seminar Nasional Teknik (SEMNASTEK) UISU, vol. 2, no. 1, pp. 59-64. 2019.
- [10] Dr.K.Kum aresan M.E, Ph.D, Prakash.S, Rajkumar.P, Sakthivel.C, Sugumar.G "Automatic Sewage Cleaning Equipment". "Interntional conference on explorations and innovationsin engineering and technology".

- [11] Shwetmala, HN Chanakya and TV Ram a chndra, Assessment of solid wastes choking open sewers and vulnerability to urban flooding 2nd International conference on solid waste management and exhibition, jadavpur University, Kolkata,9-11-2011.
- [12] Gears educational system, chain drive system, 105 Webster St. Hanover Massachusetts 02339.
- [13] Nikitas Zagoras Graduate Research Assistant Clem son University Restoration Institute, SC, Batteryenergy Store System (BESS): A cost/Benefit Analysis for a PV power station. September 2014.
- [14] Ashok Dargar, et.al, "A Method of Identification of Kinematic Chains and Distinct Mechanisms", Institute of Fundamental Technology Research, 2009.
- [15] Viki Sahebrao Bagul Yogesh Dilip Jadhay, AUTOMATIC DAINAGE CLEANING SYSTEM, International Journal of Science Technology Management and research Volume2, Issue1, February 2017.
- [16] Balachandra, et.al."Automatic Drainage Water Pump Monitoring and Control System Using PLC and SCADA" International Journal of Innovative Research in Technology, Vol No- 1, 2014.