

# Design and Fabrication of Automatic Rain Shade for Different Ambient Conditions

A report submitted to the Department of Mechanical, Sonargaon University of Bangladesh in partial fulfillment of the requirements for the Award of Degree of Bachelor of Science in Mechanical Engineering.

## Submitted by

<b>Md. Salim Hasan</b>	<b>ID: BME1703013122</b>
<b>Md. Yead Kaosar</b>	<b>ID: BME1901017101</b>
<b>Md. Shamim Reza</b>	<b>ID: BME1901017558</b>
<b>Md. Maruf Abdullah</b>	<b>ID: BME1901017178</b>
<b>Md. Shihab Hossain</b>	<b>ID: BME1901017646</b>
<b>Tuhin Al Rakib</b>	<b>ID: BME1801014088</b>



## Supervised by

**Mohammad Din Al-Amin**  
(Lecturer & Asst. Coordinator)  
Department of Mechanical Engineering  
Sonargaon University (SU)  
Dhaka-1215, Bangladesh

**September, 2022**

## Letter of Transmittal

14<sup>th</sup> September, 2022

To

The Supervisor

Department of Mechanical Engineering.

Sonargaon University of Bangladesh

**Subject: Submission of Project Report.**

Dear Sir,

We are pleased to submit the project report on “**Design and Fabrication of Automatic Rain Shade for Different Ambient Conditions**”. It was a great pleasure to work on such an important topic. This project has been done as per instruction of your supervision and according to the requirements of the Sonargaon University.

We expect that the project will be accepted by the concerned authority we will remain happy to further explanation that you may feel necessary in this regard.

Thank You

Sincerely yours,

Md. Salim Hasan  
BME1703013122

Md. Yead Kaosar  
BME1901017101

Md. Shamim Reza  
BME1901017558

Md. Maruf Abdullah  
BME1901017178

Md. Shihab Hossain  
BME1901017646

Tuhin Al Rakib  
BME1801014088

## DECLARATION

We do hereby solemnly declare that, the work presented here in this project report has been carried out by us and has not been previously submitted to any University/ Organization for award of any degree or certificate

We hereby ensure that the works that has been prevented here does not breach any existing copyright.

We further undertake to indemnify the university against any loss or damage arising from breach of the foregoing obligation.

Md. Salim Hasan  
BME1703013122

Md. Yead Kaosar  
BME1901017101

Md. Shamim Reza  
BME1901017558

Md. Maruf Abdullah  
BME1901017178

Md. Shihab Hossain  
BME1901017646

Tuhin Al Rakib  
BME1801014088

## ACKNOWLEDGEMENT

First, we started in the name of almighty Allah. This thesis is accomplished under the supervision of Supervisor Name, Designation, Department of Mechanical, Sonargaon University. It is a great pleasure to acknowledge our profound gratitude and respect to our supervisor for this consistent guidance, encouragement, helpful suggestion, constructive criticism and endless patience through the progress of this work. The successful completion of this thesis would not have been possible without his persistent motivation and continuous guidance.

The author are also grateful to Md. Mostofa Hossain , Head of the Department of Mechanical Engineering and all respect teachers of the Mechanical Engineering Department for their co-operation and significant help for completing the thesis work successfully.

[Authors]

Md. Salim Hasan  
BME1703013122

Md. Yead Kaosar  
BME1901017101

Md. Shamim Reza  
BME1901017558

Md. Maruf Abdullah  
BME1901017178

Md. Shihab Hossain  
BME1901017646

Tuhin Al Rakib  
BME1801014088

## **Abstract**

The aim of this system is to make a smart **Automatic Rain Shade for Different Ambient Conditions** which can reduce human effort due to its functionality and can target the market due to its unique design, is really important in modern society at risk of rainfall and wind without coverage in place. The purpose of this project is to make such an rain shed that is really sensitive in the incidences of rain and sunlight at domestic and market level. Specifically, in summer season the floor of open areas gets so warm due to sun light that makes difficulty for working. This system covers the entire place during the rain and sunlight. This shed operates with the help of rain sensors. The opening and closing of rain shed is being controlled through a motor automatically and manually. Motor can give a quick and instant response to the shaft so that shaft can play a major role of power transmission for opening and closing of shed. Motor provides required rpm to the shaft. Whenever rain come and after rain sensor detect the rain then the system will work automatically. Arduino sends signal further to the motor so that motor may activate and deliver required rpm to the coupling shaft. This project is a cost-effective way of providing automated controlled shade from high intensity sunlight and rain. So, the problems of open and vast areas can be solved by using such types of automated rain shed.

# TABLE OF CONTENTS

Letter of transmittal	i
Declaration	ii
Acknowledgement	iii
Abstract	iv
<b>CHAPTER-1</b>	<b>INTRODUCTION</b>
1.1 Introduction	01
1.2 Objectives	02
1.3 Organization of Book	02
<b>CHAPTER-2</b>	<b>LITERATURE REVIEW</b>
2.1 Introduction	03
2.2 Literature Review	03
2.3 Summary	04
<b>CHAPTER-3</b>	<b>STRUCTURE</b>
3.1 Block Diagram	5
3.2 Circuit Diagram	5
3.3 Components List	6
<b>CHAPTER-4</b>	<b>HARDWARE ANALYSIS</b>
4.1 Arduino Pro Mini	07
4.2 Voltage Regulator IC	09
4.3 SMPS	10
4.4 Motor Driver IC	15
4.5 Motor Driver	17
4.6 DC Gear Motor	19
4.7 Motor Pully	20
4.8 Rain Sensor	21
4.9 Bearing	23

4.10 Capacitor	25
4.11 Resistor	26
4.12 Arduino IDE	27
4.13 Proteus Software	31
<b>CHAPTER-5</b>	<b>METHODOLOGY</b>
5.1 Our Methodology of the Project	33
5.2 Complete Project Image	33
5.3 Working Principle	34
<b>CHAPTER-6</b>	<b>RESULT AND DISCUSSION</b>
6.1 Discussion	35
6.2 Result	35
6.3 Advantages	37
6.4 Application	37
6.5 Limitation	37
<b>CHAPTER-7</b>	<b>CONCLUSION</b>
7.1 Conclusion	38
7.2 Future Scope of Work	38
<b>REFERENCE</b>	<b>40</b>
<b>APPENDIX</b>	<b>42</b>

# LIST OF FIGURES

<b>FIGURE NO</b>	<b>FIGURE NAME</b>	<b>PAGE NO</b>
3.1	Block Diagram	5
3.2	Circuit Diagram	6
4.1	Arduino Pro Mini	7
4.2	Arduino Pin Out	9
4.3	VOLTAGE REGULATOR	10
4.4	SMPS	10
4.5	SMPS Circuit	12
4.6	SMPS Circuit Connection	13
4.7	L293D	15
4.8	L293D Circuit Diagram	16
4.9	Motor Driver Shield	17
4.10	Logic Diagram	18
4.11	IC Pin Out	18
4.12	Gear Motor	20
4.13	Pulley	21
4.14	Rain Sensor Pin Diagram	21
4.15	Rain Sensor Pin Description	22
4.16	Bearing	24
4.17	Capacitor	25
4.18	Smooth Capacitor	26
4.19	Resistor	27
4.20	Arduino IDE	28
4.21	Proteus Software Interface	32
5.1	Complete Prototype Picture	33
6.1	Our System in Full Open Position	35
6.2	Our System in Half Fold Position	36
6.3	Our System in Full Fold Position	36



# CHAPTER 1

## INTRODUCTION

### 1.1 Introduction

A rain shed is a folding canopy (overhead roof) supported by metal or wooden ribs that is usually mounted on a wooden, metal or plastic pole. It is designed to protect a person against sunlight and rain. rain sheds and parasols are primarily hand-held portable devices sized for personal use. The largest hand-portable rain sheds are golf rain sheds. rain sheds can be divided into two categories: Fully collapsible rain sheds, in which the metal pole supporting the canopy retracts, making the rain shed small enough to fit in a handbag and non-collapsible rain sheds, in which the support pole cannot retract and only the canopy can be collapsed.

Generally, sun shading big rain sheds is used at beaches, swimming pools or in courtyards, a lot of coffee shops or restaurants also use sun-shading big rain sheds on tables and rain-shielding but also for providing a good mood of being in the surrounding. Therefore, the big rain sheds are quite practical. For such types of purposes, an automated rain shed is required which is equipped with modern technology. The vision is to make a optimize structure which is of low cost that fulfills the need of the people working in open areas. The main function of an automated rain shed is protection from sunlight. This rain shed meets these needs by using multiple sensors and a set of DC motors to automatically track the sun to maximize shading where it is being used. DC motor is used for direct and Instant response of a current having single phase. The selection of DC motor depends upon torque. It operates whenever sun rises in morning, sensors detect light and activate the motors of rain shed which further drives the shaft to open and close the rain shed. Now a days these types of rain sheds are also be used for car parking. The purpose of doing this is to feel comfortable while working in open areas and to make a design which is really reliable for domestic and industrial purposes.

## 1.2 Objective:

The objectives of this project are:

- a) To study about **Automatic Rain Shade for Different Ambient Conditions**.
- b) To **Design and Fabrication of Automatic Rain Shade for Different Ambient Conditions**.
- c) To test the performance of the **Automatic Rain Shade for Different Ambient Conditions** system.
- d) To modelling and fabricates a **Automatic Rain Shade for Different Ambient Conditions** .
- e) To decrease the cost of machine by application of simple mechanism.

## 1.3 Organization of the Book

- **Chapter 1: Introduction.** This chapter is all about background study, motivation, Objectives and thesis book organization.
- **Chapter 2: Literature Review-** Here briefly describe about previous book review and Summary of this chapter.
- **Chapter 3: Structure-** This chapter is discussed about block diagram, circuit diagram, components of list . Here we describe our hole instrument details.
- **Chapter 4 : Hardware Analysis** - This chapter is discussed about our project hardware and Software . Here we describe our hole instrument details.
- **Chapter 5: Methodology-** Here briefly discuss about project methodology, working principle and our system overview.
- **Chapter 6: Result and Discussion-** Here briefly discuss about project discussion, result analysis, advantages, application and our system overview.
- **Chapter 7: Conclusion** – This chapter is all about our thesis future recommendation and this project conclusion.

# CHAPTER 2

## LITURATURE REVIEW

### 2.1 Introduction

This chapter mainly reviews literature, reviews of various types of work and highlights the importance of **Design and Fabrication of Automatic Rain Shade for Different Ambient Conditions** in such situations.

### 2.2 Literature review:

Many researchers have recently exploited the capability of single board microprocessors and sensors. Following section briefly describes various systems on which our work is built upon:

**A. Arduino and Water Sensor:** In recent years, water sensors along with Arduino or Raspberry Pi are used in many applications specifically related to smart irrigation. In [1] water flow sensor along with temperature sensor and soil moisture sensors are used with Arduino. Data collected by these sensors are sent to the interactive website by a WIFI module attached with an Arduino. This allows user to control water pump and sprinklers from distance which will facilitate farmer to obtain maximum quality crops. In [2] smart drip irrigation system is proposed using Arduino, Raspberry Pi and Zigbee modules. Arduino micro-controllers are used to receive the on/off commands from the Raspberry Pi using Zigbee protocol. The water pump can automatically start by just sending an email to system. In [3] Arduino and water sensors are used for measuring and monitoring water quality for fish farming. It is used to measure temperature and pH value of water. Collected data is sent via Bluetooth to mobile application for monitoring purpose.

**B. Arduino and Temperature Sensor:** Many researchers have used Arduino and temperature sensors along with GSM, GPRS, Bluetooth and Zigbee modules for automation of various systems. Some of the systems are as follows: “Home Weather Station” is a mobile weather station that displays weather details on a LCD screen [4]. The outdoor station measures temperature, pressure and humidity and send it to indoor

module for display. In [5] designed a low cost environment monitoring system using Raspberry Pi and Arduino with Zigbee. In [6] continuous heart rate and body temperature monitoring system is proposed using Arduino UNO and Android device.

**C. Arduino and Light Dependent Resistor:** Light Dependent Resistor (LDR) has used in many applications where light has to be used or sensed for automation purpose. In [7] used LDR as sensor and Light Emitting Diode (LED) as light source to design water turbidity gauge. Turbidity of water is measured by passing a light source through water to measure the intensity of light reflected. Analog data received by Arduino from LDR is converted into digital form and the result is displayed on LCD. In [8] an intelligent street light system is proposed. Street light not only depends on darkness but also on motion. Street light will only turn on if its dark and motion is detected otherwise it will stay off, thus energy is saved.

In [9] proposed origami-based automatic solar panels. Normally, solar panels are stationary and energy absorbed is not optimum. To make sure maximum solar energy is absorbed by solar panels rotational solar panels are proposed. LDR will obtain and measure sun light and solar panels will automatically rotate towards maximum sun light. Above are some of the systems that have used Arduino as microprocessor and LDR, LM 35 and water sensors individually for data collection. None of the systems have combined all these sensors and designed a system to automatically open or close a shed or an rain shed. This paper proposed a system that will automate shed depending upon temperature, light and water to facilitate user needs accordingly.

## **2.3 Summary**

From the literature discussed above, we gained a lot of knowledge and we inspired to do this project. We were able to do it with everyone tireless work.

# CHAPTER 3

## STRUCTURE

### 3.1 Block Diagram:

The main brain of our system is the Arduino Pro Mini. The way of whole project works is that we take 220V AC power from the supply voltage and then feed it to a Switch Mode Power Supply or in short SMPS module. The SMPS simply converts the 220V AC to a pure DC of 5V. We will use this 5V DC output from the SMPS to run our controller, gear motor and other units.

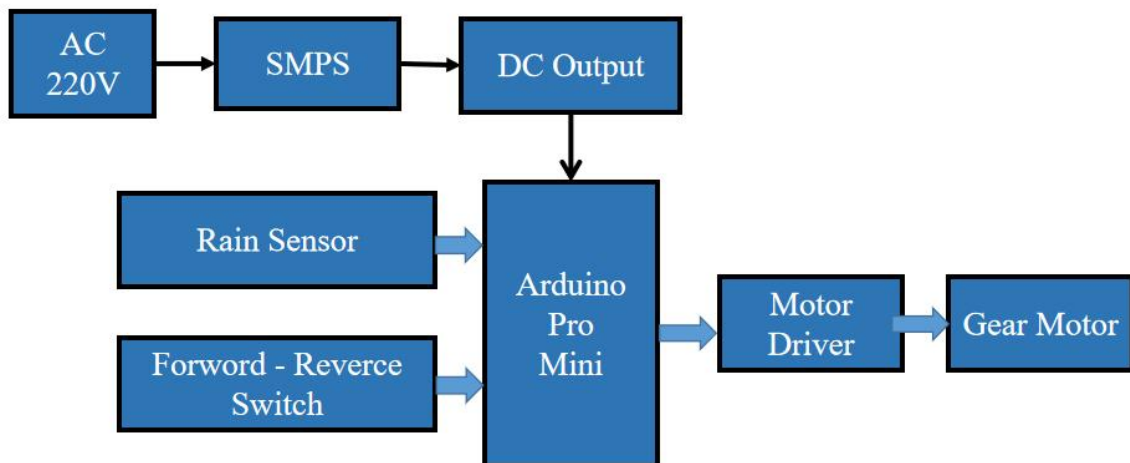

Figure 3.1: Block Diagram

### 3.2 Circuit Design

Arduino Pro Mini has been used as main controller for this project. With the help of controller which the project can be controlled our system automatically. .

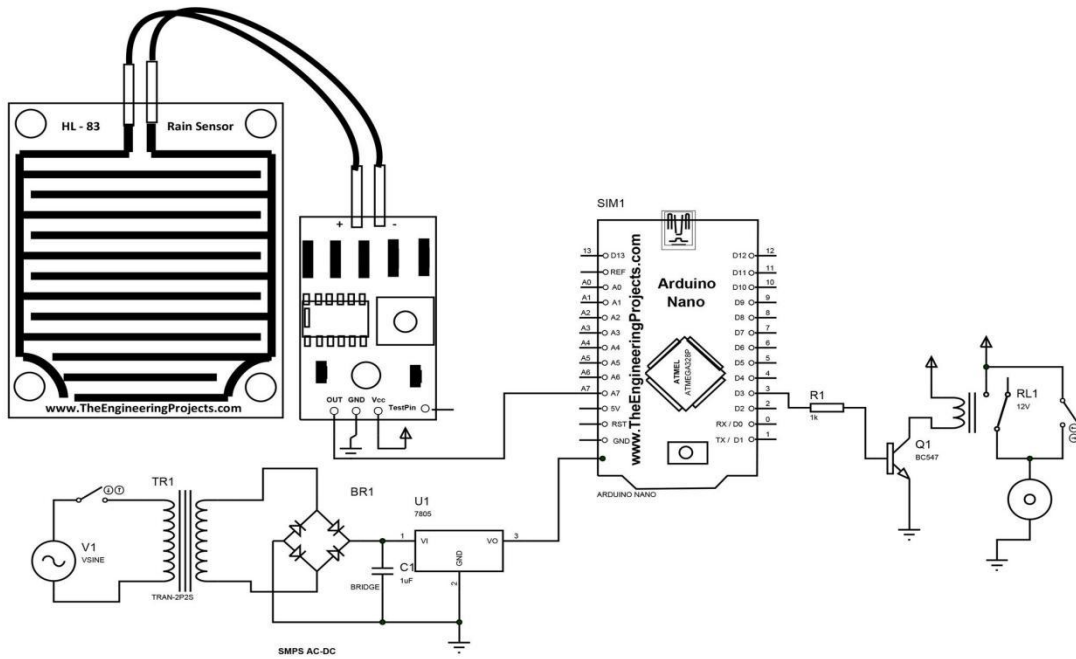

Figure 3.2: Schematic Diagram

### 3.3 Components List:

1. Arduino Pro Mini
2. SMPS
3. Gear Motor
4. Motor Driver
5. Bearing
6. Black Paper
7. Aluminum Body
8. Pully Belt
9. Motor Pully
10. Rain Sensor

### Software

1. Arduino IDE
2. Proteus

## CHAPTER 4

### HARDWARE ANALYSIS

#### 4.1 ARDUINO PRO MINI

The Arduino Pro Mini is a micro-controller board based on the ATmega168. It has 14 digital input/output pins (of which 6 can be used as PWM outputs), 6 analog inputs, an on-board resonator, a reset button, and holes for mounting pin headers. A six pin header can be connected to an FTDI cable to provide USB power and communication to the board.

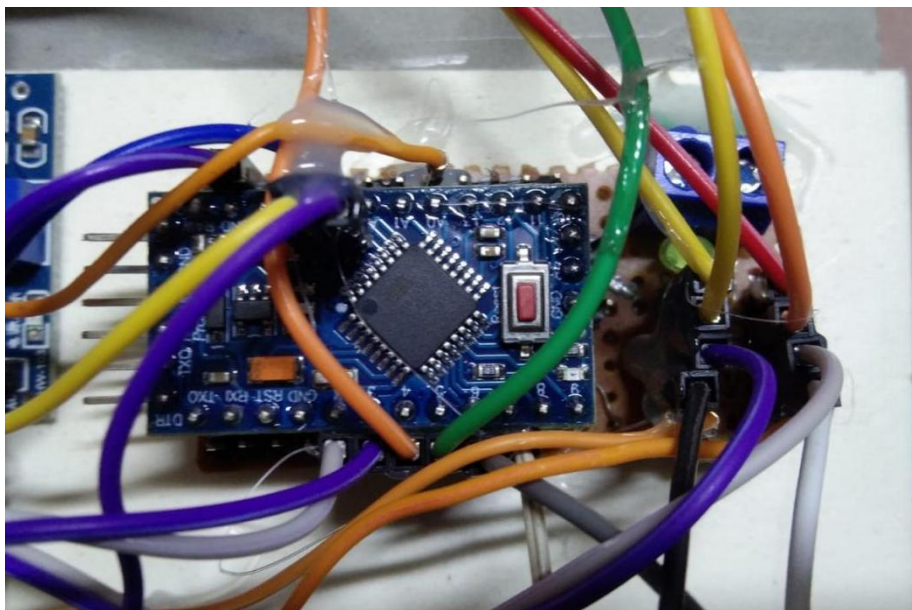

Figure 4.1: Arduino Pro Mini

#### Specification

- Micro-controller ATmega168
- Operating Voltage: 3.3V or 5V (depending on model)
- Input Voltage: 3.35 -12 V (3.3V model) or 5 - 12 V (5V model)
- Digital I/O Pins: 14 (of which 6 provide PWM output)
- Analog Input Pins: 6
- DC Current per I/O Pin: 40 mA
- Flash Memory: 16 KB (of which 2 KB used by boot loader)

- SRAM: 1 KB
- EEPROM: 512 bytes
- Clock Speed: 8 MHz (3.3V model) or 16 MHz (5V model)

## Pin Out

Each of the 14 digital pins on the Pro Mini can be used as an input or output, using `pin Mode()`, `digital Write()`, and `digital Read()` functions. They operate at 3.3 or 5 volts (depending on the model). Each pin can provide or receive a maximum of 40 mA and has an internal pull-up resistor (disconnected by default) of 20-50 kOhms. In addition, some pins have specialized functions:

- Serial: 0 (RX) and 1 (TX). Used to receive (RX) and transmit (TX) TTL serial data. These pins are connected to the TX-0 and RX-1 pins of the six pin header.
- External Interrupts: 2 and 3. These pins can be configured to trigger an interrupt on a low value, a rising or falling edge, or a change in value. See the `attachInterrupt()` function for details.
- PWM: 3, 5, 6, 9, 10, and 11. Provide 8-bit PWM output with the `analogWrite()` function.
- SPI: 10 (SS), 11 (MOSI), 12 (MISO), 13 (SCK). These pins support SPI communication, which, although provided by the underlying hardware, is not currently included in the Arduino language.
- LED: 13. There is a built-in LED connected to digital pin 13. When the pin is HIGH value, the LED is on, when the pin is LOW, it's off.

The Pro Mini has 6 analog inputs, each of which provide 10 bits of resolution (i.e. 1024 different values). Four of them are on the headers on the edge of the board; two (inputs 4 and 5) on holes in the interior of the board. The analog inputs measure from ground to VCC. Additionally, some pins have specialized functionality:



- I2C: 4 (SDA) and 5 (SCL). Support I2C (TWI) communication using the Wire library.

**There is another pin on the board:**

- Reset. Bring this line LOW to reset the micro controller. Typically used to add a reset button to shields which block the one on the board.

See also the mapping between Arduino pins and ATmega168 ports.

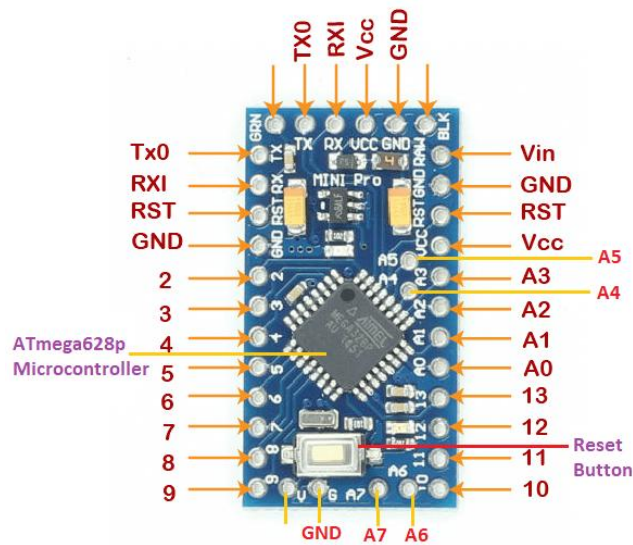

Figure 4.2: Arduino Pro Mini Pin Out

## 4.2 VOLTAGE REGULATOR IC

Voltage sources in a circuit may have fluctuations resulting in not providing fixed voltage outputs. A voltage regulator IC maintains the output voltage at a constant value. 7805 IC, a member of 78xx series of fixed linear voltage regulators used to maintain such fluctuations, is a popular voltage regulator integrated circuit (IC). The xx in 78xx indicates the output voltage it provides. 7805 IC provides +5 volts regulated power supply with provisions to add a heat sink.

### 7805 IC Rating:

- Input voltage range 7V- 35V

- Current rating  $I_c = 1A$
- Output voltage range  $V. Max=5.2V, V. Min=4.8V$



Figure 4.3: 5V Regulator IC

### 4.3 SWITCH MODE POWER SUPPLY

A switched-mode power supply (switching-mode power supply, switch-mode power supply, switched power supply, SMPS, or switcher) is an electronic power supply that incorporates a switching regulator to convert electrical power efficiently.



Figure 4.4: SMPS

Unlike a linear power supply, the pass transistor of a switching-mode supply continually switches between low-dissipation, full-on and full-off states, and spends very little time in the high dissipation transitions, which minimizes wasted energy. A hypothetical ideal switched-mode power supply dissipates no power. Voltage regulation is achieved by varying the ratio of on-to-off time (also known as duty cycles). Switching regulators are used as replacements for linear regulators when higher efficiency, smaller size or lighter weight are required. They are, however, more complicated; their switching currents can cause electrical noise problems if not carefully suppressed, and simple designs may have a poor power factor. Switched-mode power supplies are classified according to the type of input and output voltages. The four major categories are:

- AC to DC
- DC to DC
- DC to AC
- AC to AC

A basic isolated AC to DC switched-mode power supply consists of:

- Input rectifier and filter
- Inverter consisting of switching devices such as MOSFETs
- Transformer
- Output rectifier and filter
- Feedback and control circuit

The input DC supply from a rectifier or battery is fed to the inverter where it is turned on and off at high frequencies of between 20 KHz and 200 KHz by the switching MOSFET or power transistors. The high-frequency voltage pulses from the inverter are fed to the transformer primary winding, and the secondary AC output is rectified and smoothed to produce the required DC voltages. A feedback circuit monitors the output voltage and instructs the control circuit to adjust the duty cycle to maintain the output at the desired level.



voltage scaling, and multiple output voltages. The non-isolated configurations do not have a transformer and the power conversion is provided by the inductive energy transfer.

### Advantages of switched-mode power supplies:

- Higher efficiency of 68% to 90%
- Regulated and reliable outputs regardless of variations in input supply voltage
- Small size and lighter
- Flexible technology
- High power density

### Disadvantages:

- Generates electromagnetic interference
- Complex circuit design
- Expensive compared to linear supplies

Switched-mode power supplies are used to power a wide variety of equipment such as computers, sensitive electronics, battery-operated devices and other equipment requiring high efficiency.

### Switch Mode Power Supply

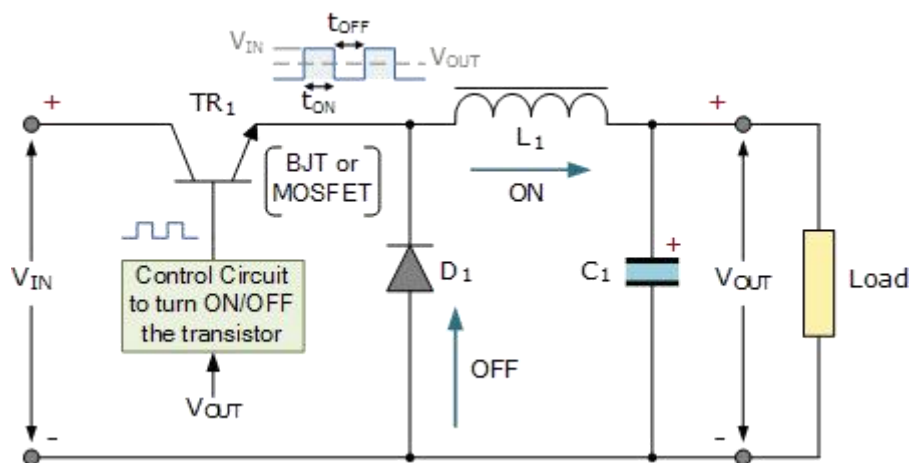
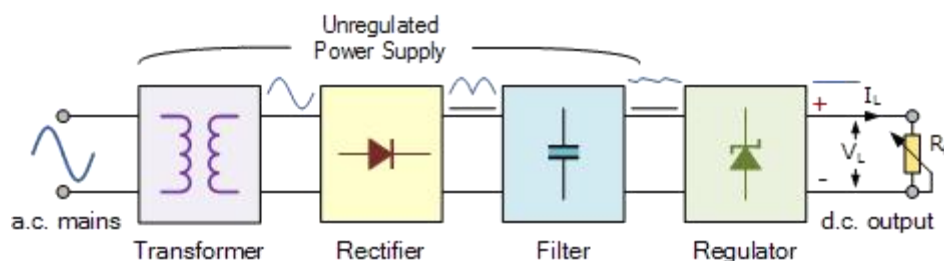

Figure 4.6: SMPS Circuit Connection

Linear voltage IC regulators have been the basis of power supply designs for many years as they are very good at supplying a continuous fixed voltage output. Linear voltage regulators are generally much more efficient and easier to use than equivalent voltage regulator circuits made from discrete components such as a zener diode and a resistor, or transistors and even op-amps. The most popular linear and fixed output voltage regulator types are by far the positive output voltage series, and the negative output voltage series. These two types of complementary voltage regulators produce a precise and stable voltage output ranging from about 5 volts up to about 24 volts for use in many electronic circuits. There is a wide range of these three-terminal fixed voltage regulators available each with its own built-in voltage regulation and current limiting circuits. This allows us to create a whole host of different power supply rails and outputs, either single or dual supply, suitable for most electronic circuits and applications. There are even variable voltage linear regulators available as well providing an output voltage which is continually variable from just above zero to a few volts below its maximum voltage output.

Most d.c. power supplies comprise of a large and heavy step-down mains transformer, diode rectification, either full-wave or half-wave, a filter circuit to remove any ripple content from the rectified d.c. producing a suitably smooth d.c. voltage, and some form of voltage regulator or stabiliser circuit, either linear or switching to ensure the correct regulation of the power supplies output voltage under varying load conditions. Then a typical d.c. power supply would look something like this:

### Typical DC Power Supply



These typical power supply designs contain a large mains transformer (which also provides isolation between the input and output) and a dissipative series regulator circuit.

The regulator circuit could consist of a single zener diode or a three-terminal linear series regulator to produce the required output voltage. The advantage of a linear regulator is that the power supply circuit only needs an input capacitor, output capacitor and some feedback resistors to set the output voltage.

#### 4.4 L293D Motor Driver IC

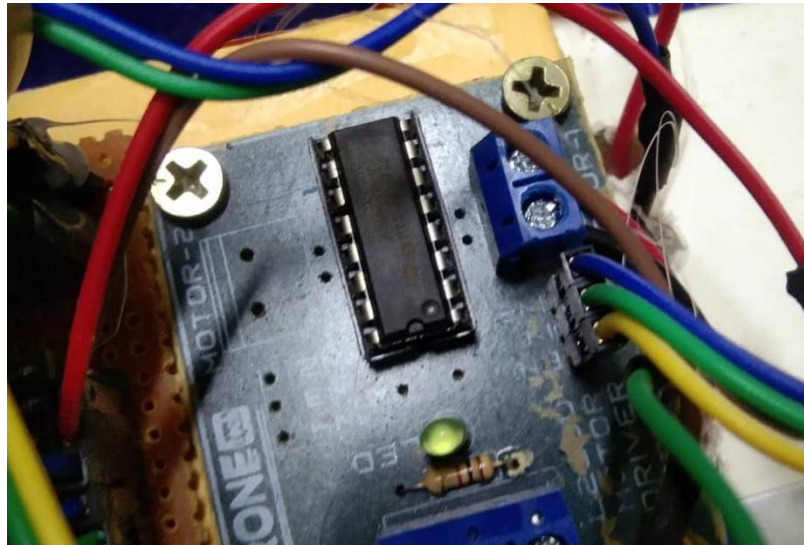

Figure 4.7: L293D

- L293D is a typical Motor driver or Motor Driver IC which allows DC motor to drive on either direction. L293D is a 16-pin IC which can control a set of two DC motors simultaneously in any direction. It means that you can control two DC motor with a single L293D IC Dual H-bridge Motor Driver integrated circuit (IC).
- It works on the concept of H-bridge. H-bridge is a circuit which allows the voltage to be flown in either direction. As you know voltage need to change its direction for being able to rotate the motor in clockwise or anticlockwise direction, hence H-bridge IC are ideal for driving a DC motor.
- In a single L293D chip there are two h-Bridge circuit inside the IC which can rotate two dc motor independently. Due its size it is very much used in robotic application for controlling DC motors. Given below is the pin diagram of a L293D motor controller.
- There are two Enable pins on l293d. Pin 1 and pin 9, for being able to drive the motor, the pin 1 and 9 need to be high. For driving the motor with left H-bridge

you need to enable pin 1 to high. And for right H-Bridge you need to make the pin 9 to high. If anyone of the either pin1 or pin9 goes low then the motor in the corresponding section will suspend working. It's like a switch.

- There are 4 input pins for l293d, pin 2, 7 on the left and pin 15, 10 on the right as shown on the pin diagram. Left input pins will regulate the rotation of motor connected across left side and right input for motor on the right hand side. The motors are rotated on the basis of the inputs provided across the input pins as LOGIC 0 or LOGIC 1.
- In simple you need to provide Logic 0 or 1 across the input pins for rotating the motor.

### L293D Logic:

Let's consider a Motor connected on left side output pins (pin 3, 6). For rotating the motor in clockwise direction the input pins has to be provided with Logic 1 and Logic 0.

- Pin 2 = Logic 1 and Pin 7 = Logic 0 | Clockwise Direction
- Pin 2 = Logic 0 and Pin 7 = Logic 1 | Anticlockwise Direction
- Pin 2 = Logic 0 and Pin 7 = Logic 0 | Idle [No rotation] [Hi-Impedance state]
- Pin 2 = Logic 1 and Pin 7 = Logic 1 | Idle [No rotation]

In a very similar way the motor can also operate across input pin 15, 10 for motor on the right hand side.

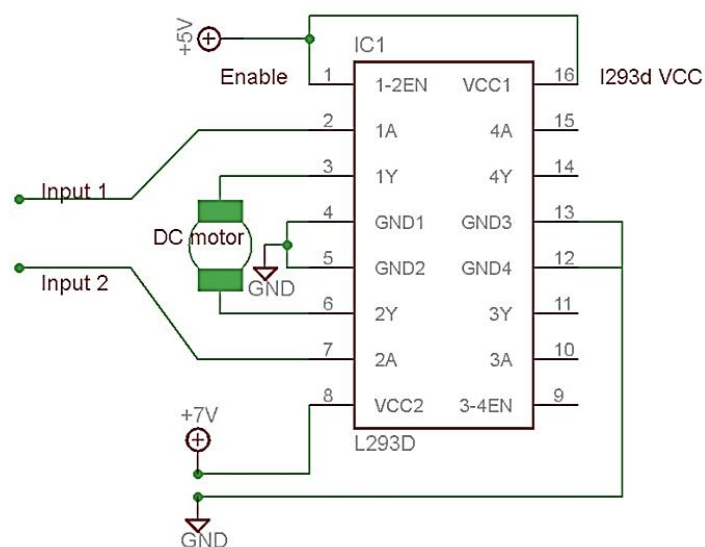
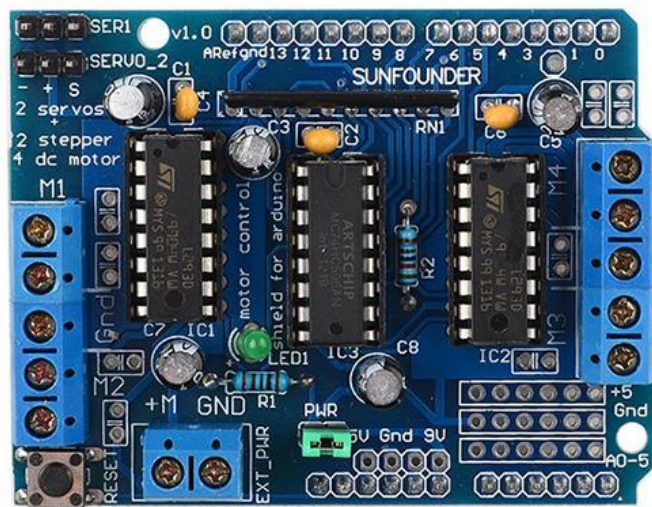

Figure 4.8: L293D circuit diagram



## 4.5 Arduino Motor Driver

L293D is a monolithic integrated, high voltage, high current, 4-channel driver. Basically this means using this chip you can use DC motors and power supplies of up to 16 Volts, that's some pretty big motors and the chip can supply a maximum current of 600mA per channel, the L293D chip is also what's known as a type of H-Bridge. The H-Bridge is typically an electrical circuit that enables a voltage to be applied across a load in either direction to an output, e.g. motor.



**Figure 4.9: L293D Motor Driver Shield**

The L293D is quadruple high-current half-H drivers. It is designed to provide bidirectional drive currents of up to 600-mA at voltages from 4.5 V to 36 V. Both devices are designed to drive inductive loads such as relays, solenoids, dc and bipolar stepping motors, as well as other high-current/high-voltage loads in positive-supply applications. All inputs are TTL compatible. Each output is a complete totem-pole drive circuit, with a Darlington transistor sink and a pseudo-Darlington source. Drivers are enabled in pairs, with drivers 1 and 2 enabled by 1,2EN and drivers 3 and 4 enabled by 3,4EN. When an enable input is high, the associated drivers are enabled, and their outputs are active and in phase with their inputs. When the enable input is low, those drivers are disabled, and their outputs are off and in the high-impedance state. With the proper data inputs, each pair of drivers forms a full-H (or bridge) reversible drive suitable for solenoid or motor applications.

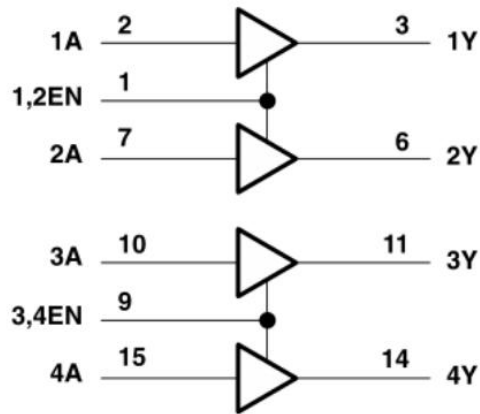

Logic diagram

Figure 4.10: Logic Diagram

**Pin Function:**

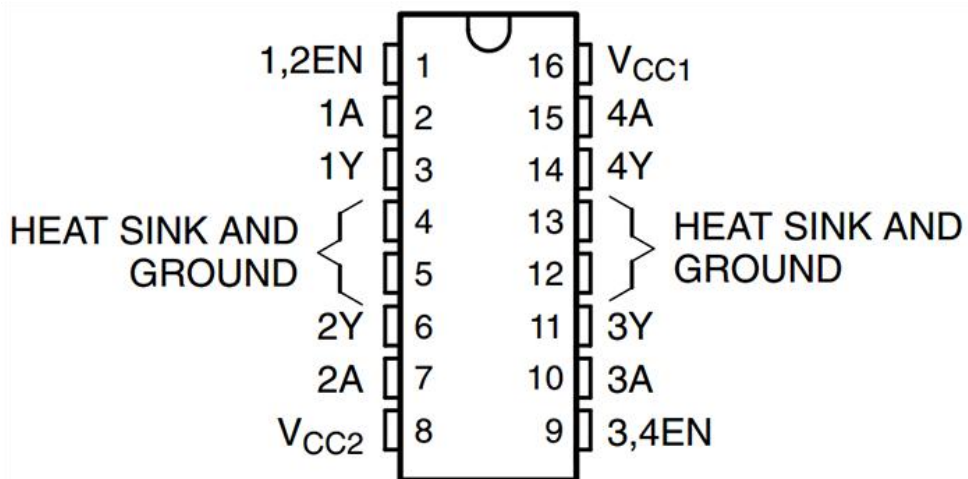

Figure 4.11: IC Pin Out

Pin	Name	Function
1	Enable1,2	Enable pin to control 1,2 driver
2	Input 1A	Input to control 1Y
3	Output 1Y	Output, connect to motor
4	GND	Ground and heat sink
5	GND	Ground and heat sink
6	Output 2Y	Output, connect to motor
7	Input 2A	Input to control 2Y
8	Vcc2	Output supply voltage

9	Enable3,4	Enable pin to control 3,4 driver
10	Input 3A	Input to control 3Y
11	Output 3Y	Output, connect to motor
12	GND	Ground and heat sink
13	GND	Ground and heat sink
14	Output 4Y	Output, connect to motor
15	Input 4A	Input to control 4Y
16	Vcc1	Supply voltage (7 max)

**Table 1: IC Pin Out**

## Features

- Wide Supply-Voltage Range: 4.5 V to 36 V
- Separate Input-Logic Supply
- Internal ESD Protection
- Thermal Shutdown
- High-Noise-Immunity Inputs
- Output Current 600 mA Per Channel
- Peak Output Current 1.2 A Per Channel

## 4.6 DC Gear Motor

### Description:

A DC motor is any motor within a class of electrical machines whereby direct current electrical power is converted into mechanical power. ... A 12v DC motor is small and inexpensive, yet powerful enough to be used for many applications.

### Specification:

- Voltage: 12V DC
- Gear ratio: 1/31
- No-load speed: 200RPM
- Rated Speed: 140RPM

- Rated torque: 10kg.cm
- Rated current: 2.5Amp
- Length of Motor(including spindle): 106mm/4.17"
- Diameter: 37mm/1.45"
- Shaft length: 21mm/0.82"
- Shaft diameter: 6mm/0.24"

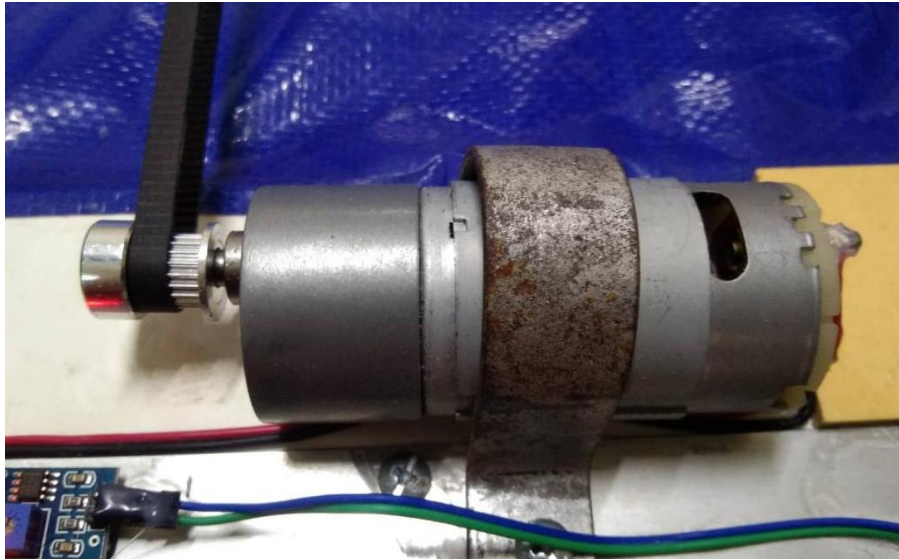

Figure 4.12: DC Gear Motor

#### 4.7 Motor Pulley

A **pulley** is a wheel on an axle or shaft that is designed to support movement and change of direction of a taut cable or belt, or transfer of power between the shaft and cable or belt. In the case of a pulley supported by a frame or shell that does not transfer power to a shaft, but is used to guide the cable or exert a force, the supporting shell is called a block, and the pulley may be called a sheave. A pulley may have a groove or grooves between flanges around its circumference to locate the cable or belt. The drive element of a pulley system can be a rope, cable, belt, or chain. The earliest evidence of pulleys dates back to Ancient Egypt in the Twelfth Dynasty (1991-1802 BCE) and Mesopotamia in the early 2nd millennium BCE. In Roman Egypt, Hero of Alexandria (c. 10-70 CE) identified the pulley as one of six simple machines used to lift weights. Pulleys are assembled to form a block and tackle in order to provide mechanical advantage to apply large forces. Pulleys are also assembled as part of belt and chain drives in order to transmit power from

one rotating shaft to another. Plutarch's *Parallel Lives* recounts a scene where Archimedes proved the effectiveness of compound pulleys and the block-and-tackle system by using one to pull a fully laden ship towards him as if it was gliding through water.

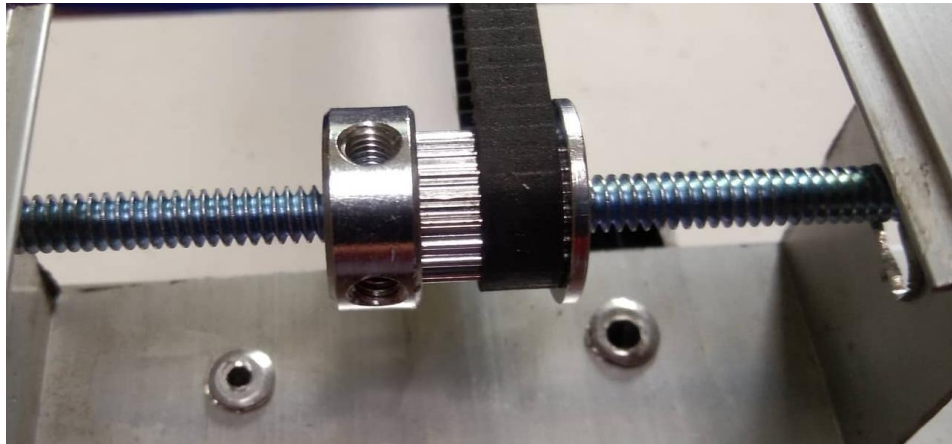

Figure 4.13: Pulley

#### 4.8 Rain sensor

A rain sensor is one kind of low-cost electronic sensor which is used to detect the rainfall or water drops. It works as a switch. Normally the switch is open condition. This sensor is consists of mainly two parts, one is Sensing Pad and another one is the Sensor Module. When rainfall or water drops fall on the Sensing Pad surface, then the switch will be closed.

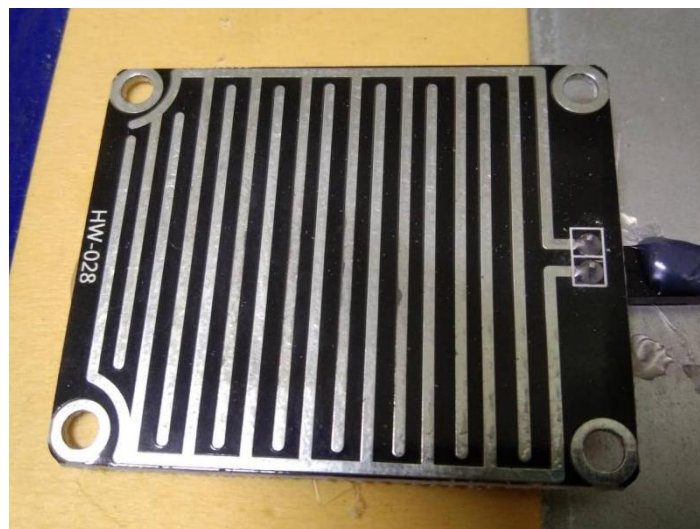

Figure 4.14: Rain Sensor Pin Diagram

The Sensor Module reads data from the sensor pad and processes the data and converts it into a digital/analog output. So, the sensor can provide both types of output Digital output (DO) and Analog output(AO). The Rain Sensor Module's Sensing Pad consists of two nickel-coated series copper tracks. Also, it has **two Header pins**, these are internally connected to the two copper tracks of the Sensing Pad. These pins are used to connect the Sensing Pad to the rain sensor module circuit through two jumper wire. Always, one pin of the rain sensor circuit provides a +5v power supply to the one track of the sensing pad, and another pin is received the return power supply from another track of the sensing pad. Normally under dry conditions, the sensing pad provides high resistance and low conductive. So, the 5v power supply cannot be passed from one track to another track. Its resistance varies according to the amount of water on the surface of the sensing pad. When water drops fall on the sensor pad surface its resistance will decrease and conductivity will increase. So, when water drops increase on the pad surface it can pass more power supply through one track to another track.



Figure 4.15: Rain Sensor Pin Indication & Description

Figure 02 : Rain sensor Pin Description

	Pin Name	Description
1	VCC	+5 v power supply
2	GND	Ground (-) power supply

3	<b>DO</b>	Digital Output (0 or 1)
4	<b>AO</b>	Analog Output (range 0 to 1023)

### Sensor Module Hardware Overview

The Sensor module is consists of some key components. These are LM393 Comparators, Variable Resistor (Trimpot), Power LED, output LED.

## Rain Sensor Specifications

Table 03: Rain Sensor Specialization

Parameter	Value
Operating Voltage	3.3V – 5V
Operating Current	15 mA
Comparator chip	LM393
Sensitivity	Adjustable via Trimpot
Output type	Analog output voltage (AO) and Digital switching voltage (DO)
LED lights indicators	Power (red/green) and Output (red/green)
Sensing pad	5cm x 4 cm nickel plate on one side.
Module PCB Size	3.2cm x 1.4cm

### Application

- Rainfall detection
- It's used in an irrigation system, when rainfall is started it shut down the watering system automatically.

## 4.9 BEARING

A **bearing** is a machine element that constrains relative motion to only the desired motion, and reduces friction between moving parts. The design of the bearing may, for example, provide for free linear movement of the moving part or for free rotation around a fixed axis; or, it may prevent a motion by controlling the vectors of normal forces that bear on the moving parts. Most bearings facilitate the desired motion by minimizing friction. Bearings are classified broadly according to the type of operation, the motions allowed, or to the directions of the loads (forces) applied to the parts. Rotary bearings hold rotating components such as shafts or axles within mechanical systems, and transfer axial and radial loads from the source of the load to the structure supporting it. The simplest form of bearing, the plain bearing, consists of a shaft rotating in a hole. Lubrication is used to reduce friction. In the ball bearing and roller bearing, to reduce sliding friction, rolling elements such as rollers or balls with a circular cross-section are located between the races or journals of the bearing assembly. A wide variety of bearing designs exists to allow the demands of the application to be correctly met for maximum efficiency, reliability, durability and performance.



Figure4.16: Bearing



## 4.10 CAPACITOR

When there is a potential difference across the conductors (e.g., when a capacitor is attached across a battery), an electric field develops across the dielectric, causing positive charge (+Q) to collect on one plate and negative charge (-Q) to collect on the other plate. If a battery has been attached to a capacitor for a sufficient amount of time, no current can flow through the capacitor. However, if an accelerating or alternating voltage is applied across the leads of the capacitor, a displacement current can flow.



Figure 4.17: Capacitor

An ideal capacitor is characterized by a single constant value for its capacitance. Capacitance is expressed as the ratio of the electric charge (Q) on each conductor to the potential Difference (V). The SI unit of capacitance is the farad (F), which is equal to one coulomb per volt (1 C/V). Typical capacitance values range from about 1 pF ( $10^{-12}$  F) to about 1 mF ( $10^{-3}$  F). The capacitance is greater when there is a narrower separation between conductors and when the conductors have a larger surface area. In practice, the dielectric between the plates passes a small amount of leakage current and also has an electric field strength limit, known as the breakdown voltage. The conductors and leads introduce an undesired inductance and resistance. Capacitors are widely used in electronic circuits for blocking direct current while allowing alternating current to pass. In analog filter networks, they smooth the output of power supplies. In resonant circuits they tune radios to particular frequencies. In electric power transmission systems, they stabilize voltage and power flow.

The full-wave bridge rectifier however, gives us a greater mean DC value ( $0.637 V_{max}$ ) with less superimposed ripple while the output waveform is twice that of the frequency of the input supply frequency. We can improve the average DC output of the rectifier while

at the same time reducing the AC variation of the rectified output by using smoothing capacitors to filter the output waveform. Smoothing or reservoir capacitors connected in parallel with the load across the output of the full wave bridge rectifier circuit increases the average DC output level even higher as the capacitor acts like a storage device as shown below. Too low a capacitance value and the capacitor has little effect on the output waveform. But if the smoothing capacitor is sufficiently large enough (parallel capacitors can be used) and the load current is not too large, the output voltage will be almost as smooth as pure DC.

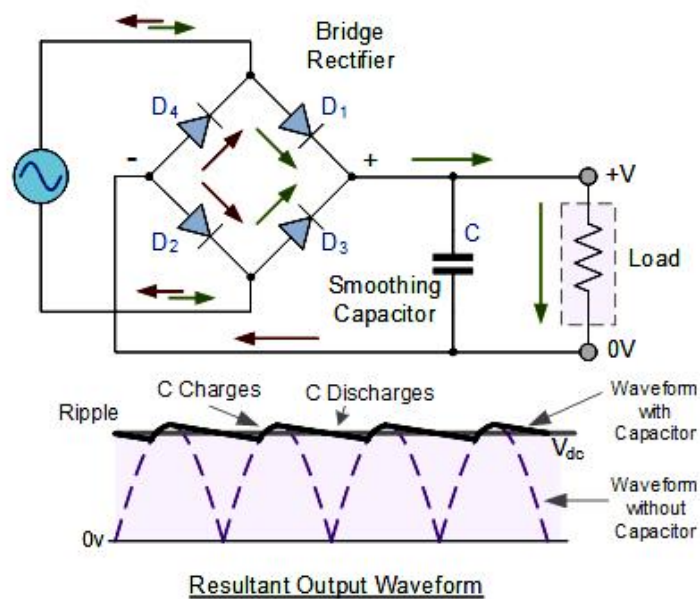

Figure 4.18: The Smoothing Capacitor with Full Bridge Rectifier

## 4.11 RESISTOR

A resistor is a passive two-terminal electrical component that implements electrical resistance as a circuit element. Resistors act to reduce current flow, and, at the sometime, act to lower voltage levels within circuits. Resistors may have fixed resistances or variable resistances, such as those founding thermostats, visitors, trimmers, photo resistors, hamsters and potentiometers. The current through a resistor is in direct proportion to the voltage across the resistor's terminals. This relationship is represented by Ohm's law.



**Figure 4.19:** Resistor

### **Theory of operation:**

The behavior of an ideal resistor is dictated by the relationship specified by Ohm 'slaw:

$$V = I.R$$

Ohm's law states that the voltage (V) across a resistor is proportional to the current (I), where the constant of proportionality is the resistance (R).

Equivalently, Ohm's law can be stated:

$$I = V/R$$

This formulation states that the current (I) is proportional to the voltage (V) and inversely proportional to the resistance (R). This is directly used in practical computations. For example, if a 300 ohm resistor is attached across the terminals of a 12 volt battery, then a current of  $12 / 300 = 0.04$  amperes flows through that resistor.

## **4.12 Arduino IDE**

The digital microcontroller unit named as Arduino Nano can be programmed with the Arduino software IDE. There is no any requirement for installing other software rather than Arduino. Firstly, Select "Arduino Nano from the Tools, Board menu (according to the microcontroller on our board). The IC used named as ATmega328 on the Arduino Nano comes pre burned with a boot loader that allows us to upload new code to it without the use of an external hardware programmer.

Communication is using the original STK500 protocol (reference, C header files). We can also bypass the boot loader and programs the microcontroller through the ICSP (In Circuit Serial Programming) header. The ATmega16U2 (or 8U2 in the rev1 and rev2 boards) firmware source code is available. The ATmega16U2/8U2 is loaded with a DFU boot

loader, which can be activated by:

On Rev1 boards: connecting the solder jumper on the back of the board (near the map of Italy) and then resetting the 8U2. On Rev2 or later boards: there is a resistor that pulling the 8U2/16U2 HWB line to ground, making it easier to put into DFU mode.

The Arduino Nano is one of the latest digital microcontroller units and has a number of facilities for communicating with a computer, another Arduino, or other microcontrollers. The ATmega328 provides UART TTL at (5V) with serial communication, which is available on digital pins 0 -(RX) for receive the data and pin no.1 (TX) for transmit the data. An ATmega16U2 on the board channels this serial communication over USB and appears as a virtual com port to software on the computer. The '16U2 firmware uses the standard USB COM drivers, and no external driver is needed. However, on Windows, an .in file is required. The Arduino software includes a serial monitor which allows simple textual data to be sent to and from the Arduino board.

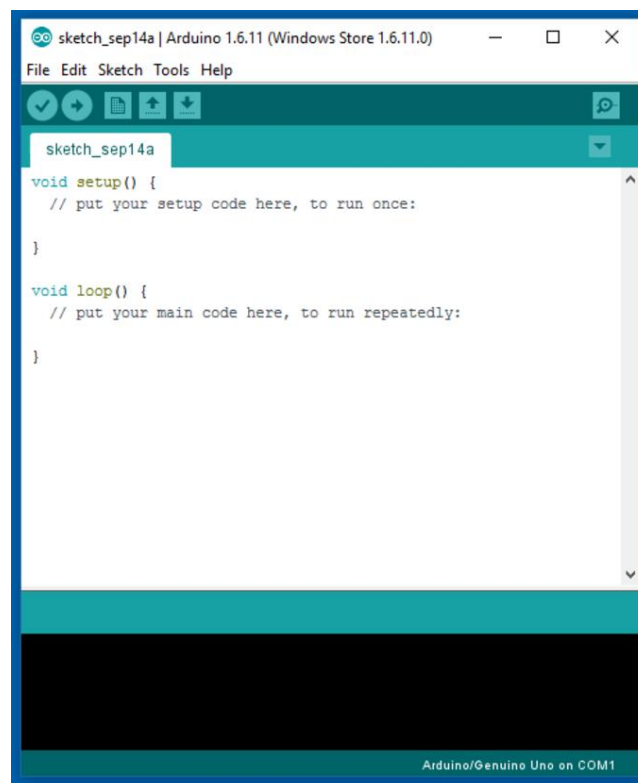

Figure 4.20: Arduino Software Interface IDE

The RX and TX LEDs on the board will flash when data is being transmitted via the USB-to-serial chip and USB connection to the computer (but not for serial

Communication on pins 0 and 1). A Software Serial library allows for serial communication on any of the Nano's digital pins. The ATmega328 also supports I2C (TWI) and SPI communication. The Arduino software includes a Wire library to simplify use of the I2C bus. Arduino programs are written in C or C++ and the program code written for Arduino is called sketch. The Arduino IDE uses the GNU tool chain and AVR Lab to compile programs, and for uploading the programs it uses avrdude. As the Arduino platform uses Atmel micro-controllers, Atmel's development environment, AVR Studio or the newer Atmel Studio, may also be used to develop software for the Arduino. The Arduino Integrated Development Environment - or Arduino Software (IDE) - contains a text editor for writing code, a message area, a text console, a toolbar with buttons for common functions and a series of menus. It connects to the Arduino and Genuino hardware to upload programs and communicate with them.

### **Writing Sketches**

Programs written using Arduino Software (IDE) are called sketches. These sketches are written in the text editor and are saved with the file extension .ino. The editor has features for cutting/pasting and for searching/replacing text. The message area gives feedback while saving and exporting and also displays errors. The console displays text output by the Arduino Software (IDE), including complete error messages and other information. The bottom right hand corner of the window displays the configured board and serial port. The toolbar buttons allow you to verify and upload programs, create, open, and save sketches, and open the serial monitor.

### **Sketchbook**

The Arduino Software (IDE) uses the concept of a sketchbook: a standard place to store your programs (or sketches). The sketches in your sketchbook can be opened from the File > Sketchbook menu or from the Open button on the toolbar. The first time you run the Arduino software, it will automatically create a directory for your sketchbook. You can view or change the location of the sketchbook location from with the Preferences dialog. Beginning with version 1.0, files are saved with a .ino file extension. Previous versions use the .pde extension. You may still open .pde named files in version 1.0 and later, the software will automatically rename the extension to .ino.

### **Tabs, Multiple Files, and Compilation**

Allows you to manage sketches with more than one file (each of which appears in its own tab). These can be normal Arduino code files (no visible extension), C files (.c extension), C++ files (.cpp), or header files (.h).

## **Uploading**

Before uploading your sketch, you need to select the correct items from the Tools > Board and Tools > Port menus. The boards are described below. On the Mac, the serial port is probably something like /dev/tty.usbmodem241 (for a Uno or Mega2560 or Leonardo) or /dev/tty.usbserial-1B1 (for a Duemilanove or earlier USB board), or /dev/tty.USA19QW1b1P1.1 (for a serial board connected with a Keyspan USB-to-Serial adapter). On Windows, it's probably COM1 or COM2 (for a serial board) or COM4, COM5, COM7, or higher (for a USB board) - to find out, you look for USB serial device in the ports section of the Windows Device Manager. On Linux, it should be /dev/ttyACMx , /dev/ttyUSBx or similar. Once you've selected the correct serial port and board, press the upload button in the toolbar or select the Upload item from the Sketch menu. Current Arduino boards will reset automatically and begin the upload. With older boards (pre-Diecimila) that lack auto-reset, you'll need to press the reset button on the board just before starting the upload. On most boards, you'll see the RX and TX LEDs blink as the sketch is uploaded. The Arduino Software (IDE) will display a message when the upload is complete, or show an error.

When you upload a sketch, you're using the Arduino Bootloader, a small program that has been loaded on to the microcontroller on your board. It allows you to upload code without using any additional hardware. The Bootloader is active for a few seconds when the board resets; then it starts whichever sketch was most recently uploaded to the microcontroller. The Bootloader will blink the on-board (pin 13) LED when it starts (i.e. when the board resets).

## **Libraries**

Libraries provide extra functionality for use in sketches, e.g. working with hardware or manipulating data. To use a library in a sketch, select it from the Sketch > Import Library menu. This will insert one or more #include statements at the top of the sketch and compile the library with your sketch. Because libraries are uploaded to the board with your sketch, they increase the amount of space it takes up. If a sketch no longer needs a

library, simply delete its `#include` statements from the top of your code. There is a list of libraries in the reference. Some libraries are included with the Arduino software. Others can be downloaded from a variety of sources or through the Library Manager. Starting with version 1.0.5 of the IDE, you can import a library from a zip file and use it in an open sketch. See these instructions for installing a third-party library.

### **Third-Party Hardware**

Support for third-party hardware can be added to the hardware directory of your sketchbook directory. Platforms installed there may include board definitions (which appear in the board menu), core libraries, Bootloaders, and programmer definitions. To install, create the hardware directory, then unzip the third-party platform into its own sub-directory. (Don't use "Arduino" as the sub-directory name or you'll override the built-in Arduino platform.) To uninstall, simply delete its directory. For details on creating packages for third-party hardware, see the Arduino IDE 1.5 3rd party Hardware specification.

### **Serial Monitor**

This displays serial sent from the Arduino or Genuino board over USB or serial connector. To send data to the board, enter text and click on the "send" button or press enter. Choose the baud rate from the drop-down menu that matches the rate passed to `Serial begin` in your sketch. Note that on Windows, Mac or Linux the board will reset (it will rerun your sketch) when you connect with the serial monitor.

## **4.13 Proteus Software**

The Proteus Design Suite is a proprietary software tool suite used primarily for electronic design automation. The software is used mainly by electronics design engineers and technicians to create schematics and electronics prints for manufacturing printed circuit boards. The first version of what is now the Proteus Design Suite was called PC-B and was written by the company chairman, John Jameson, for DOS in 1988. Schematic Capture support followed in 1990 with a port to the Windows environment shortly thereafter. Mixed mode SPICE Simulation was first integrated into Proteus in 1996 and microcontroller simulation then arrived in Proteus in 1998. Shape based auto routing was

added in 2002 and 2006 saw another major product update with 3D Board Visualization. More recently, a dedicated IDE for simulation was added in 2011 and MCAD import/export was included in 2015. Support for high speed design was added in 2017. Feature led product releases are typically biannual, while maintenance-based service packs are released as required.

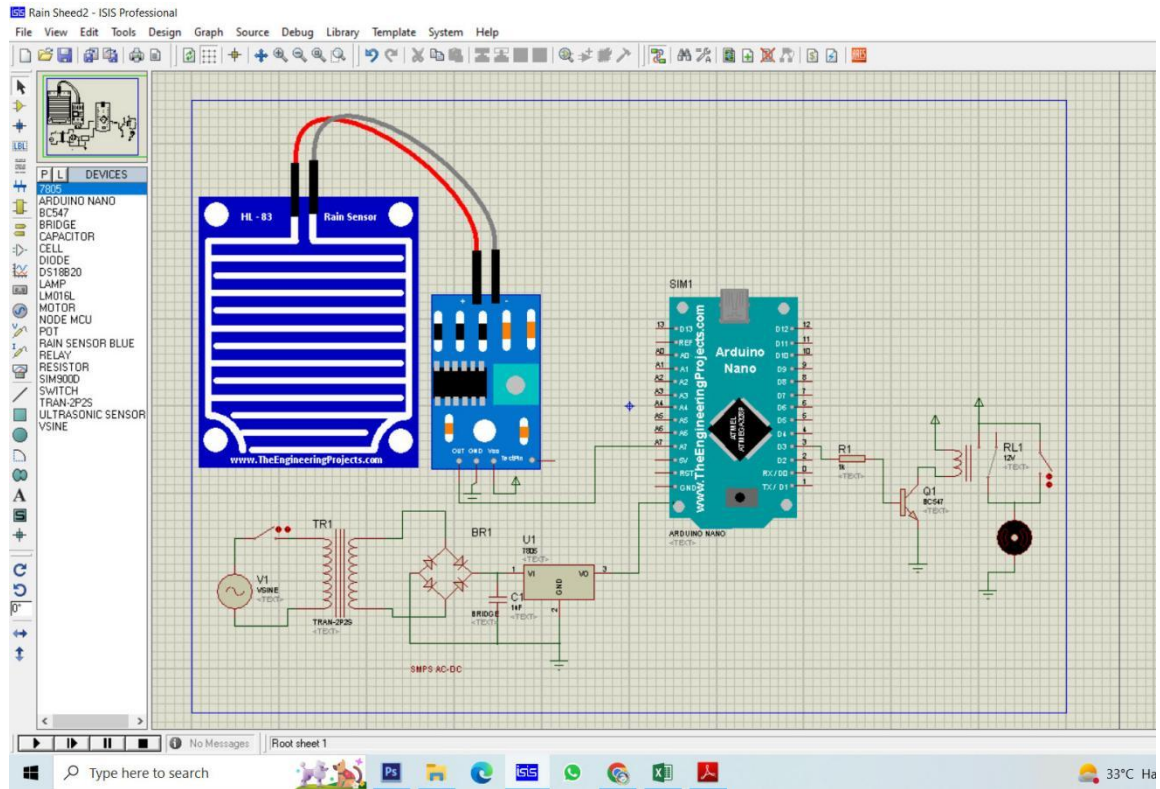

Figure 4.21: Proteus Software Interface



## CHAPTER 5

### METHODOLOGY

#### 5.1 Methodology

- Creating an idea for **Design and Fabrication of Automatic Rain Shade for Different Ambient Conditions**. And drawing and listed of components/materials to know which components/materials need to construct it.
- Collecting the all components/materials for construct the system.
- Finally, we constructed this system & checked it finally that working very well.

#### 5.2 Complete Project Prototype Image :

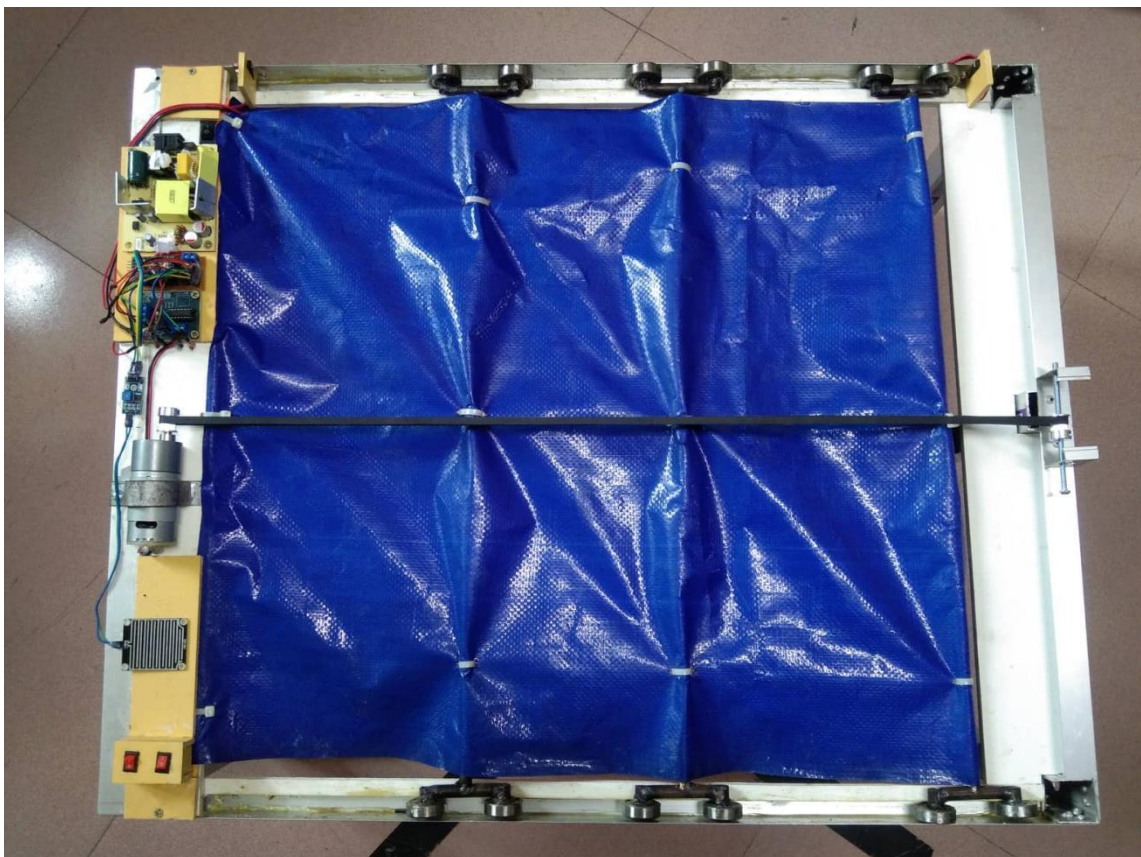

Figure 5.1: Complete Project Picture

### **5.3 Working Principle**

The main brain of our system is the Arduino Pro Mini. The way of whole project works is that we take 220V (rms) AC power from the supply voltage and then feed it to a Switch Mode Power Supply or in short SMPS module. The SMPS simply converts the 220V AC to a pure DC of 5V. We will use this 5V DC output from the SMPS to run our micro-controller, sensor and other units.

Here we use arduino pro mini, smps, rain sensor, gear motor, bearing motor pully and pully belt. Our project main work is provide automatic rain shed. In rain sensor detect water then the system will get a signal by the rain sensor and send it to the controller. Micro controller send a signal to motor driver IC. Then motor driver drive the gear motor at a certain speed and fold or expand of the shed. And provide a protection from rain. It also work in manually. It is the main purpose of this system.

## CHAPTER 6

### RESULT AND DISCUSSION

#### 6.1 Discussion

In this project we added all of this equipment and setup it properly. Then observe our system. In the very beginning time, we can't do it properly, after a great teamwork we solve our problem and finally able to measure water level, water temperature and weather condition like rain and end notification in our phone, After using this system we really know our pond condition.

#### 6.2 Result

Now, it's time to talk about the results. We have written our commands using the Arduino IDE and the following things can happen:

- When this project is run then it will sense the rain on the rain sensor then the shed will fold or extend automatically.
- It is also operate it manually.

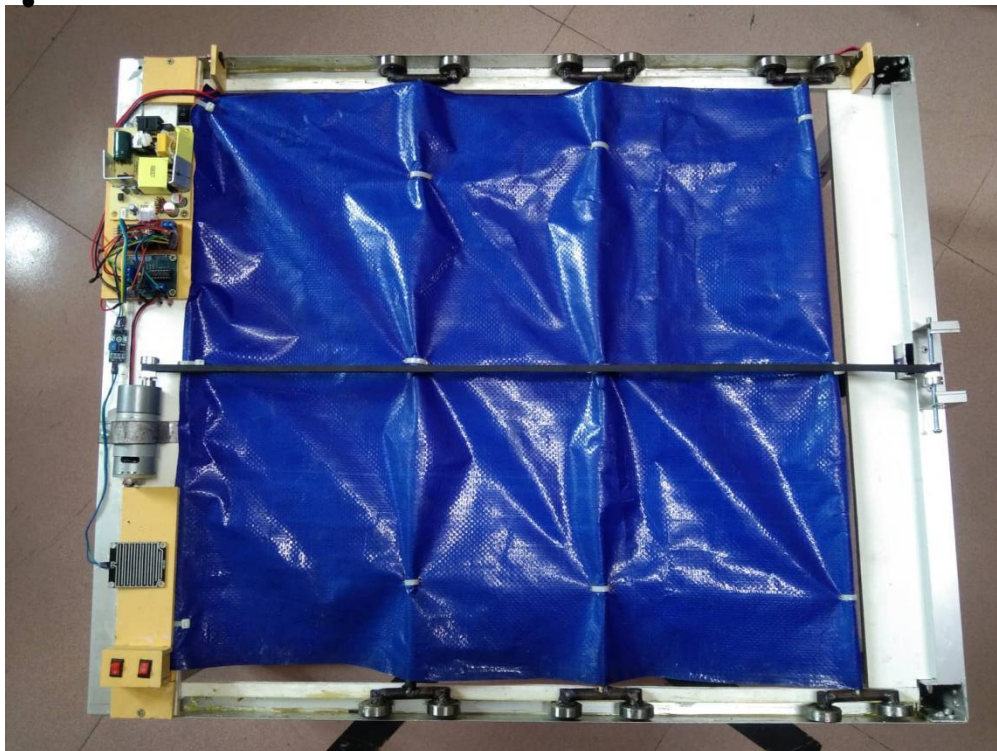

Figure 6.1: Our System in Full Open Position

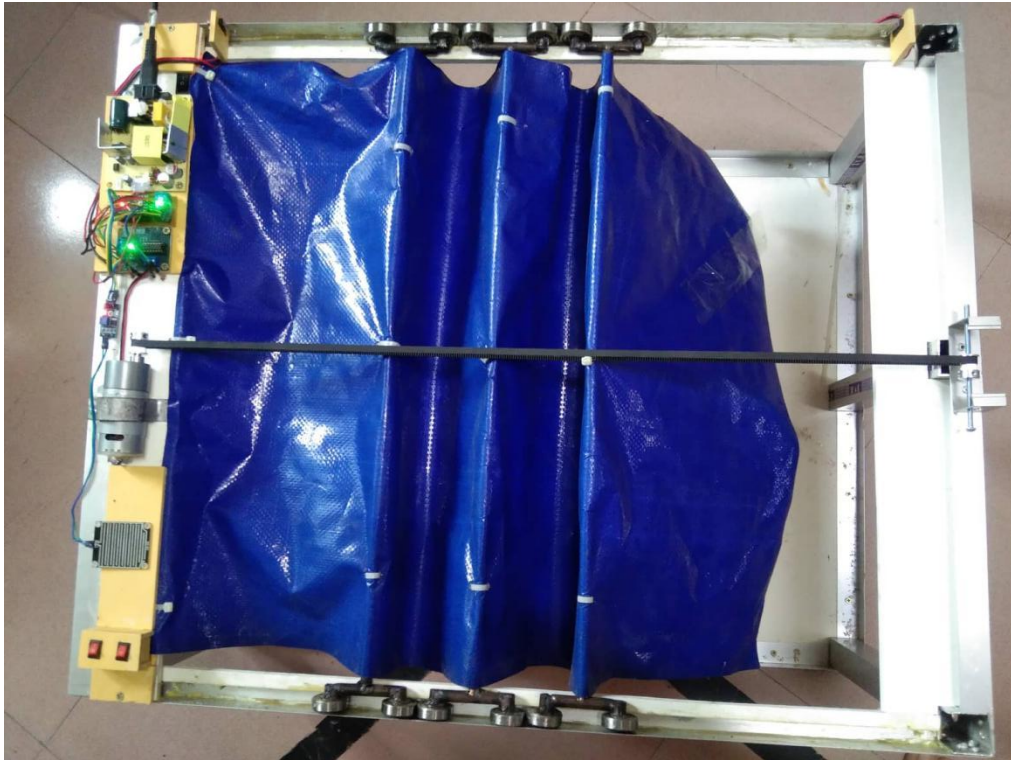

Figure 6.2: Our System in Half Fold Position

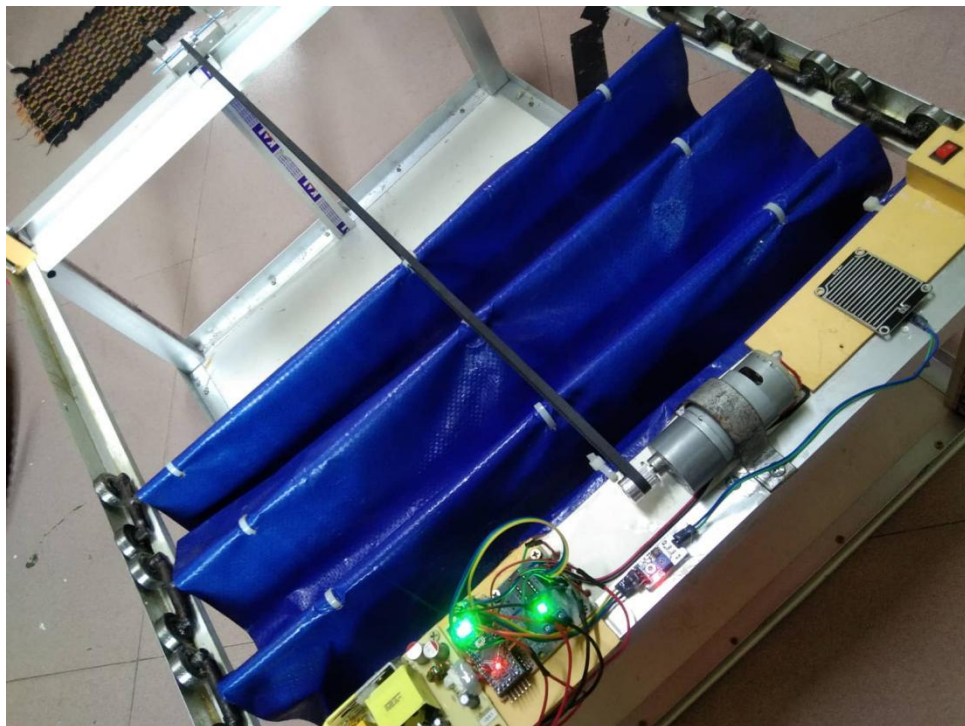

Figure 6.3: Our System in Full Fold Position

### **6.3 Advantage**

- Automatic Rain protection System
- Automatic and Manual Control
- Time saving machine for industrial work.
- No Oil consumption.
- Time saving equipment.
- Installation is simplified very much.
- Simple construction
- Ease of operation.

### **6.4 Application**

The project has a major application in the

- It can be used for Industrial work.
- It can be used in football field
- It can be use rooftop garden

### **6.5 Limitation**

It is a demo project so we found some limitation. In future we will work for reduce this kind of limitation. These limitations are –

- It is a demo project so it has some error.
- Our project may delay in work.

## **CHAPTER 7**

### **CONCLUSION**

#### **7.1 Conclusion**

This is real time model which is used to automatic rain water and crop saving system protects crops from excess amount of rain water and also saves water from wastage. By using Arduino operations of the entire system is going to be controlled these system saves the electricity, maximizes the productivity during both rainy season and sunny season. Controlling of system on users virtue can also be achieved through device like rain sensor. hardware implementation are reliable and cheap of this project.

#### **7.2 Future Scope**

The model can be improved by making some changes in the program and components. Some suggestions are given below-

- We will increase its working accuracy level.
- We will think about adding leaser cutting and PCB Design.

## Reference:

- [1] Carlisle, R. P. (2004). Scientific American inventions and discoveries: all the milestones in ingenuity from the discovery of fire to the invention of the microwave oven. said.
- [2] Day, S. T. (1985). U.S. Patent No. 4,534,374. Washington, DC: U.S. Patent and Trademark Office.
- [3] Engst, C., Chhokar, R., Miller, A., Tate, R. B., & Yassi, A. (2005). Effectiveness of overhead lifting devices in reducing the risk of injury to care staff in extended care facilities. *Ergonomics*, 48(2), 187-199.
- [4] Gingerich, B. S., & Ondeck, D. A. (1998). Pocket guide for the home care aide. Jones & Bartlett Learning.
- [5] Hui, L., Ng, G. Y., Yeung, S. S., & Hui-Chan, C. W. (2001). Evaluation of physiological work demands and low back neuromuscular fatigue on nurses working in geriatric wards. *Applied ergonomics*, 32(5), 479-483.
- [6] Li, W. Y. (2011). U.S. Patent No. 8,061,374. Washington, DC: U.S. Patent and Trademark Office.
- [7] Martinec, A. E. C. (2011). U.S. Patent No. 7,909,048. Washington, DC: U.S. Patent and Trademark Office.
- [8] Meng, S. H., Huang, A. C., Lee, C. J., Huang, T. J., & Dal, J. N. (2017, November). Design for intelligent control system of curtain based on Arduino. In *International Conference on Smart Vehicular Technology, Transportation, Communication and Applications* (pp. 178-184). Springer, Cham.
- [9] Nelson, A., Matz, M., Chen, F., Siddharthan, K., Lloyd, J., & Fragala, G. (2006). Development and evaluation of a multifaceted ergonomics program to prevent injuries associated with patient handling tasks. *International journal of nursing studies*, 43(6), 717-733.

- [10] OHSAH. (2004). Memorandum of understanding with regards to manual patient handling between the association of unions and health employers association of British Columbia. Vancouver. B.Occupational Health and Safety Agency for Healthcare in British Columbia, British Colombia.
- [11] Portis Jr, M. N., & Hampton, O. (2013). U.S. Patent No. 8,497,656. Washington, DC: U.S. Patent and Trademark Office.
- [12] Smith-Temple, J., & Johnson, J. Y. (2005). Nurses' guide to clinical procedures.



## Appendix

```
int for_button = 2;
```

```
int rev_button = 3;
```

```
int motor1 = 4;
```

```
int motor2 = 5;
```

```
int rain = 6;
```

```
int rainn;
```

```
int limit1 = 7;
```

```
int limit2 = 8;
```

```
void setup() {
```

```
  Serial.begin(9600);
```

```
  pinMode(for_button,INPUT);
```

```
  pinMode(rev_button,INPUT);
```

```
  pinMode(rain,INPUT);
```

```
  pinMode(limit1,INPUT);
```

```
  pinMode(limit2,INPUT);
```

```
  pinMode(motor1,OUTPUT);
```

```
  pinMode(motor2,OUTPUT);
```

```
    digitalWrite(motor1,LOW);
```

```
    digitalWrite(motor2,LOW);
```

```
}
```

```
void loop() {
```

```
  int forward = digitalRead(for_button);
```

```
  int reverse = digitalRead(rev_button);
```

```
  int forward_limit = digitalRead(limit1);
```

```
  int reverse_limit = digitalRead(limit2);
```

```
rainn = digitalRead(rain);
Serial.print("forward: ");
Serial.println(forward);
Serial.print("reverse: ");
Serial.println(reverse);
Serial.print("forward_limit: ");
Serial.println(forward_limit);
Serial.print("reverse_limit: ");
Serial.println(reverse_limit);
Serial.println(rainn);
```

```
if(reverse == HIGH ){
    digitalWrite(motor1,LOW);
    digitalWrite(motor2,HIGH);
}
```

```
if(rainn == HIGH ){
    digitalWrite(motor1,HIGH);
    digitalWrite(motor2,LOW);
}
```

```
if(rainn == HIGH && reverse_limit == HIGH ){
    digitalWrite(motor1,LOW);
    digitalWrite(motor2,LOW);
}
if(rainn == LOW){
    digitalWrite(motor1,LOW);
    digitalWrite(motor2,HIGH);
}
```

```
if(rainn == LOW && forward_limit == HIGH){
    digitalWrite(motor1,LOW);
    digitalWrite(motor2,LOW);

}
if(forward == HIGH ){
    digitalWrite(motor1,LOW);
    digitalWrite(motor2,HIGH);
}
if(forward == HIGH && forward_limit == HIGH){
    digitalWrite(motor1,LOW);
    digitalWrite(motor2,LOW);
}

if(reverse == HIGH ){
    digitalWrite(motor1,HIGH);
    digitalWrite(motor2,LOW);
}
if(reverse == HIGH && reverse_limit == HIGH){
    digitalWrite(motor1,LOW);
    digitalWrite(motor2,LOW);
}

delay(100);
}
```