

Chapter 1

1.1 INTRODUCTION

Generally, a refrigerant is cycled through four stages of a vapor compression refrigeration cycle, the cycle are evaporation, compression, condensation, and expansion. Before the commercial usage of CFC refrigerants, the first-generation refrigerants constituted by methyl chloride (CH_3Cl), ammonia, carbon-dioxide, and sulphur dioxide (SO_2). The general characteristic of these refrigerants is highly toxic and corrosive in nature. [1]. The second-generation refrigerants such as di-chloro-difluoro-methane (R12) and monofluoro-tri-chloromethane (R11) had been invented and used in central air-conditioning plants. The second-generation refrigerants are then called Chlorofluorocarbon (CFC). It was identified that 1 mol of CFC can deplete 100,000 ozone molecules which cause ozone depletion problem.[2]. For eliminating Ozone depletion, the Hydrofluorocarbons (HFC) refrigerants such as di-fluoro-ethane (HFC-152a), tetrafluoro-ethane (R-134a) are introduced and it contains hydrogen, chlorine, fluorine, and carbon atoms. The United States Environmental Agency concluded in its annual report saying that due to unregulated use, HFC's could be causing an equivalent amount of global warming as that formed by the release of 10,000 megatons of carbon-di-oxide per year. [3].

If we compare LPG earlier than with R134a. The coefficient of performance (COP) of the system increases by 9.5% and the power consumption is reduced by 12%, when compared with R134a. Therefore, LPG can successfully substitute R134a in domestic refrigerators. [4].

In LPG cylinders, the working fluid is already liquified at high pressure before passing through the system. As for the commercially available compressed natural gas (CNG) and liquified petroleum gas (LPG) are the most used fuels for personal car, particularly in (SI) engines. And LPG is used most of the cooking scenario Both CNG and LPG produce a cooling effect when they are evaporated in vaporizer units. LPG is a popular alternative fuel that can be used in refrigeration systems by charging directly into the evaporator by passing it through an expansion device. The purpose of this project is to offer insight into different researches that have been undertaken to further investigate the cooling characteristics of a LPG refrigeration system, including their results and further experiments proposed in the following researches.

1.2 RESEARCH PROBLEM STATEMENT

The main objective of the report has been done to show the total working procedure and the related other aspect of LPG Refrigeration and Burner System with Low Operating Cost, and other refrigeration system details and their efficiency as well. The broad objectives of this research are mainly understanding the functional operations and analyzing system of various devices properly and can get the best efficiency. The knowledge about fabrication LPG Refrigeration and Burner System with Low Operating Cost will be help full our practical life. If we can get a cooling solution when LPG or CNC flow through a capillary tube and the other end the main function like lighting a burner, cooking and CNG car running normally so why we not use the full functionality of LPG or CNG cylinder!

1.3 OBJECTIVES

The Objectives of this project “LPG Refrigeration and Burner System with Low Operating Cost” are as follows:

- 1) To identify the form of residual waste in traditional refrigeration system.
- 2) Compare the important characteristics between LPG refrigeration system and traditional refrigeration system.
- 3) To distinguish between the current existing refrigerator cost and estimated cost of LPG refrigerator.
- 4) The performance of existing refrigerator and LPG refrigerator is to be compared.
- 5) To obtain the characteristic benefits of LPG refrigerant.
- 6) To determine the COP of refrigerator using LPG as refrigerant.
- 7) To benefit the Cooling effect at free of cost by eliminating the compressor.
- 8) To produce an eco-friendly refrigeration system, by green technology that eliminates the use of ozone depleting refrigerants.

1.4 SCOPE OF WORK

We are replacing the compressor and condenser with a LPG cylinder. The pressure energy of LPG is very high as it can be pressurized up to 12.5 bars. Therefore, this pressure of LPG can be used for refrigeration by the usage of this LPG system also very affordable.

- It can be useful in remote parts where electricity is not available.
- It can play an important role in restaurants where continuously cooling and heating is required.
- It can be used in automobiles running on LPG or other Gaseous fuels for air conditioning.

1.5 METHODOLOGY

LPG expands when it is converted into gaseous form. Due to this expansion, there is a pressure drop and increase in volume of LPG that results in the drop of temperature and a refrigerating effect is produced. This refrigerating process can be used for cooling. This work provides refrigeration for essential needs as well as replaces global warming-causing refrigerants. Based on literature review of LPG refrigeration systems, Conventional VCR (Vapor Compression Refrigeration System) uses LPG as refrigerant and produces a cooling effect. But our proposed is very simple type of refrigeration system, the high-pressure LPG is passing through a capillary tube and expands. After expansion the phase of LPG is changed and converted from liquid to gas and then it passes through the evaporator where it absorbs the heat and produces the refrigerating effect. After evaporator it passes through the gas burner where it burns.

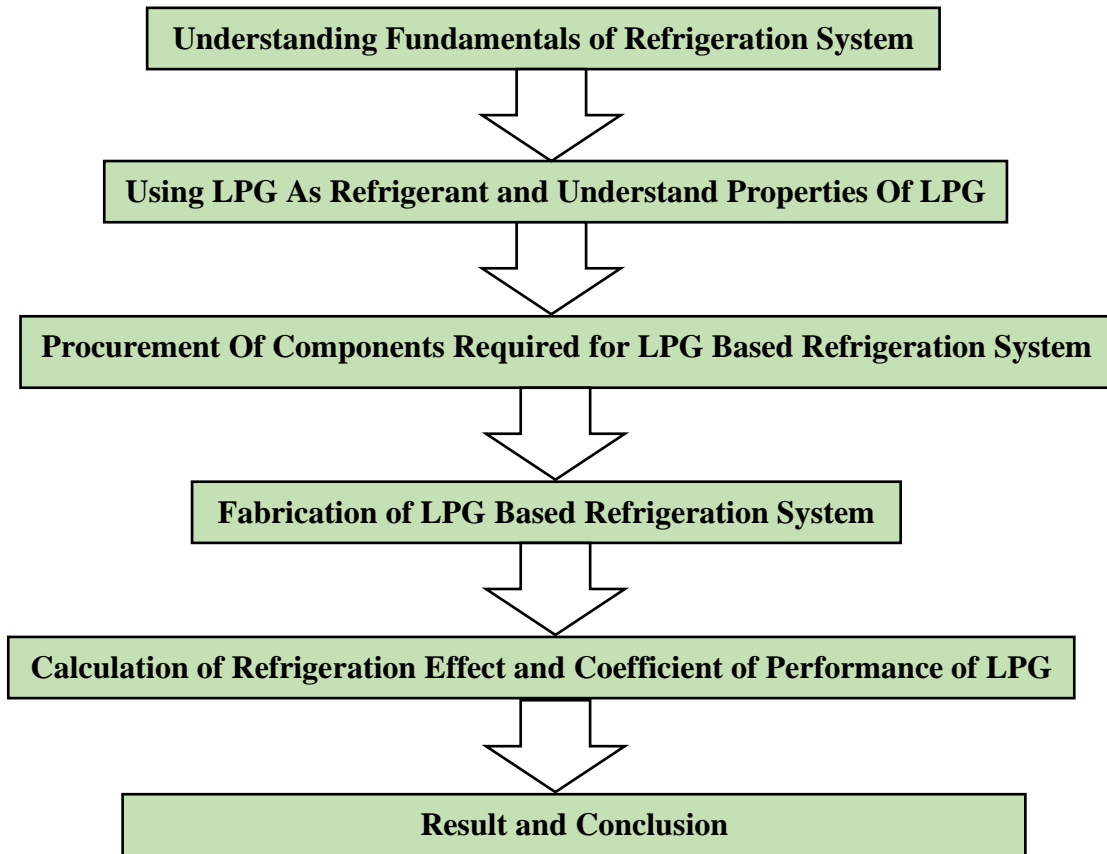

Figure. 1 Methodology

Chapter 2

2.1 LITERATURE REVIEW

Zainal Zakaria¹ & Zulaikhashahrum had performed experiments on Domestic refrigerators which annually consume approximately 17,500 metric tons of traditional refrigerants such as Chlorofluorocarbon (CFC) and Hydrofluorocarbon (HFC) which contribute to very high Global Warming Potential (GWP) and Ozone Depletion Potential (ODP). Progress is being made to slowly phase out of CFC 22 from modern equipment manufacture by replacing LPG since it has an environmentally friendly nature with no ozone depletion potential. [5].

Mhaske M. S., Deshmukh have performed experiments on designed and analyzed on refrigerator using LPG as refrigerant. The pressure of LPG is high and this is stored in cylinder. Based on the principle of adiabatic expansion of a refrigerant (in this case LPG) from 80 psi to 10 psi, as this pressurized LPG is passed through the capillary tube of small internal diameter, the pressure of LPG decreases due to expansion and phase change from liquid to gas of LPG occurs in an isenthalpic process. Due to phase change, latent heat of evaporation is gained by the liquid refrigerant and the temperature decreases. In this way refrigerating effect is produced by LPG in the surrounding. From experimental investigations, we have found that the COP of a LPG Refrigerator is higher than a domestic refrigerator. [6].

M. Mohan raj have studied experimentally the drop in substitute for R134a with the environment friendly, energy efficient hydrocarbon (HC) mixture which consists of 45% HC290 and 55% R600a at various mass charges of 50g, 70g and 90g in domestic refrigerator. The experiments were carried out in 165 liters domestic refrigerator using R134a with POE oil as lubricant. The discharge temperatures of this mixtures were found lower than R134a by 13.76%, 6.42% and 3.66% for 50g, 70g and 90g respectively. The power consumption of this mixture at 50g and 70g were lower by 10.2% and 5.1% respectively and 90g showed higher power consumption by 1.01%. The percentage reduction in pull down time is 18.36%, 21.76% and 28.57% for 50, 70 and 90g mass charges respectively when compared to R134a. The HC mixture has high energy efficiency which will reduce the indirect global warming. In conclusion HC mixture of 70g is found to be an effective alternative to R134a in 165 liters domestic refrigerator. [7].

3.1 REFRIGERATION:

Refrigeration is the process of removing heat from a substance to reduce and maintain lower temperature than its surroundings is called Refrigeration, the aim is to cool some product to the required temperature. The most important applications of refrigeration has been the preservation of rotting food at low temperatures. Refrigeration systems are also used to preserve medicine, blood and other medical tings. The history of refrigeration is very interesting since every aspect of it, the availability of refrigerants, the prime movers and the developments in compressors and the methods of refrigeration all are a part of it.

3.2 NATURAL REFRIGERATION

In olden days refrigeration was achieved by natural means such as the use of ice or evaporative cooling. In earlier times, ice was either:

1. Transported from colder regions
2. Harvested in winter and stored in ice houses for summer use or,
3. Made during night by cooling of water by radiation to stratosphere.

In Europe, America and Iran a number of icehouses were built to store ice. Materials like sawdust or wood shavings were used as insulating materials in these icehouses. Later on, cork was used as insulating material.

3.3 EVAPORATIVE COOLING

As the name indicates, evaporative cooling is the process of reducing the temperature of a system by evaporation of water. Evaporative cooling has been used for centuries to obtain cold water in summer by storing the water in earthen pots. The water permeates through the pores of earthen vessel to its outer surface where it evaporates to the surrounding, absorbing its latent heat in part from the vessel, which cools the water. Suitably located chimneys in the rooms augmented the upward flow of warm air, which was replaced by cool air. Evaporative cooling by placing wet straw mats on the windows is also very common. Now-adays desert coolers are being used in hot and dry areas to provide cooling in summer.

3.4 COOLING BY SALT SOLUTIONS

Certain substances such as common salt, when added to water dissolve in water and absorb its heat of solution from water (endothermic process). This reduces the temperature of the solution (water + salt). Sodium Chloride salt (NaCl) can yield temperatures up to -20°C and Calcium Chloride (CaCl_2) up to -50°C in properly insulated containers. However, as it is this process has limited application, as the dissolved salt has to be recovered from its solution by heating.

3.5 DOMESTIC REFRIGERATION SYSTEMS

The domestic refrigerator using natural ice (domestic ice box) was invented in 1803 and was used for almost 150 years without much alteration. The domestic ice box used to be made of wood with suitable insulation. Ice used to be kept at the top of the box, and low temperatures are produced in the box due to heat transfer from ice by natural convection. A drip pan is used to collect the water formed due to the melting of ice. The box has to be replenished with fresh ice once all the ice melts. Though the concept is quite simple, the domestic ice box suffered from several disadvantages. The user has to replenish the ice as soon as it is consumed, and the lowest temperatures that could be produced inside the compartment are limited.

3.6 VAPOR ABSORPTION REFRIGERATION SYSTEMS

John Leslie in 1810 kept H_2SO_4 and water in two separate jars connected together. H_2SO_4 has very high affinity for water. It absorbs water vapor and this becomes the principle of removing the evaporated water vapor requiring no compressor or pump. H_2SO_4 is an absorbent in this system that has to be recycled by heating to get rid of the absorbed water vapor, for continuous operation. Windhausen in 1878 used this principle for absorption refrigeration system, which worked on H_2SO_4 . Ferdinand Carre invented aqua-ammonia absorption system in 1860. Water is a strong absorbent of NH_3 . If NH_3 is kept in a vessel that is exposed to another vessel containing water, the strong absorption potential of water will cause evaporation of NH_3 requiring no compressor to drive the vapors. A liquid pump is used to increase the pressure of strong solution. The strong solution is then heated in a generator and passed through a rectification column to separate the water from ammonia. The ammonia vapor is then condensed and recycled. The pump power is negligible hence; the system runs virtually on low- grade energy used for heating the strong solution to separate the water from ammonia.

Another variation of vapor absorption system is the one based on Lithium Bromide water. This system is used for chilled water air-conditioning system. This is a descendent of Windhausen's machine with LiBr replacing H_2SO_4 . In this system LiBr is the absorbent and water is the refrigerant. This system works at vacuum pressures. The condenser and the generator are housed in one cylindrical vessel and the evaporator and the absorber are housed in second vessel. This also runs on low-grade energy requiring a boiler or process steam.

3.7 GAS CYCLE REFRIGERATION

If air at high pressure expands and does work (say moves a piston or rotates a turbine), its temperature will decrease. This fact is known to man as early as the 18th century. Dalton and Gay Lusaac studied this in 1807. Sadi Carnot mentioned this as a well-known phenomenon in 1824. However, Dr. John Gorrie a physician in Florida developed one such machine in 1844 to produce ice for the relief of his patients suffering from fever. This machine used compressed air at 2 atm. pressure and produced brine at a temperature of -7°C , which was then used to produce ice. Alexander Carnegie Kirk in 1862 made an air cycle cooling machine. This system used steam

engine to run its compressor. Using a compression ratio of 6 to 8, Kirk could produce temperatures as low as 40°C. Paul Gifford in 1875 perfected the open type of machine. This machine was further improved by T B Lightfoot, A Haslam, Henry Bell and James Coleman. The basic system consists of a compressor, an expander and a heat exchanger. Air from the cold room is compressed in the compressor. The hot and high-pressure air rejects heat to the heat sink (cooling water) in the heat exchanger. The warm but high-pressure air expands in the expander. The cold air after expansion is sent to the cold room for providing cooling. The work of expansion partly compensates the work of compression; hence both the expander and the compressor are mounted on a common shaft.

3.8 STEAM JET REFRIGERATION SYSTEM

If water is sprayed into a chamber where a low pressure is maintained, a part of the water will evaporate. The enthalpy of evaporation will cool the remaining water to its saturation temperature at the pressure in the chamber. Obviously lower temperature will require lower pressure. Water freezes at 0°C hence temperature lower than 4°C cannot be obtained with water. In this system, high velocity steam is used to entrain the evaporating water vapor. High-pressure motive steam passes through either convergent or convergent-divergent nozzle where it acquires either sonic or supersonic velocity and low pressure of the order of 0.009 kPa corresponding to an evaporator temperature of 4°C. The high momentum of motive steam entrains or carries along with it the water vapor evaporating from the flash chamber. Because of its high velocity it moves the vapors against the pressure gradient up to the condenser where the pressure is 5.6-7.4 kPa corresponding to condenser temperature of 35-45°C. The motive vapor and the evaporated vapor both are condensed and recycled. This system is known as steam jet refrigeration system.

Chapter 4

4.1 VAPOR COMPRESSION REFRIGERATION SYSTEMS

The basis of modern refrigeration is the ability of liquids to absorb enormous quantities of heat as they boil and evaporate. This process involves two thermodynamic concepts, the vapor pressure and the latent heat. A liquid is in thermal equilibrium with its own vapor at a pressure called the saturation pressure, which depends on the temperature alone. If the pressure is increased for example in a pressure cooker, the water boils at higher temperature. The second concept is that the evaporation of liquid requires latent heat during evaporation. If latent heat is extracted from the liquid, the liquid gets cooled. The temperature of ether will remain constant as long as the vacuum pump maintains a pressure equal to saturation pressure at the desired temperature. This requires the removal of all the vapors formed due to vaporization. If a lower temperature is desired, then a lower saturation pressure will have to be maintained by the vacuum pump. The component of the modern-day refrigeration system where cooling is produced by this method is called evaporator. If this process of cooling is to be made continuous the vapors have to be recycled by condensation to the liquid state. The condensation process requires heat rejection to the surroundings. It can be condensed at atmospheric temperature by increasing its pressure.

4.2 WORKING OF VCR SYSTEM

A vapor compression refrigeration system is an improved type of air refrigeration system in which a suitable working substance, termed as refrigerant is used. It condensed and evaporates at temperatures and pressures close to the atmospheric conditions. The refrigerants usually used for this purpose are ammonia, carbon dioxide and Sulphur dioxide.

4.3 MECHANISM OF SIMPLE VAPOR COMPRESSION REFRIGERATION SYSTEM

Compression refrigeration cycles take advantage of the fact that highly compressed fluids at a certain temperature tend to get colder when they are allowed to expand. If the pressure change is high enough, then the compressed gas will be hotter than our source of cooling (outside air, for instance) and the expanded gas will be cooler than our desired cold temperature. In this case, fluid is used to cool a low temperature environment and reject the heat to a high temperature environment.

Compression refrigeration cycles take advantage of the fact that highly compressed fluids at a certain temperature tend to get colder when they are allowed to expand. If the pressure change is high enough, then the compressed gas will be hotter than our source of cooling (outside air, for instance) and the expanded gas will be cooler than our desired cold temperature. In this case, fluid is used to cool a low temperature environment and reject the heat to a high temperature environment. Vapor compression refrigeration cycles have two advantages. First, a large amount of thermal energy is required to change a liquid to a vapor, and therefore a lot of heat can be removed from the airconditioned space. Second, the isothermal nature of the vaporization allows

extraction of heat without raising the Simple Vapor Compression Refrigeration System temperature of the working fluid to the temperature of whatever is being cooled.

The refrigeration cycle is shown in Figure below and can be broken down into the following stages:

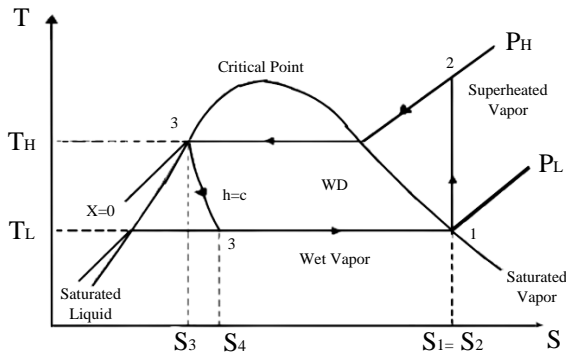

Figure. 2 T-S diagram of simple vapor compression refrigeration cycle

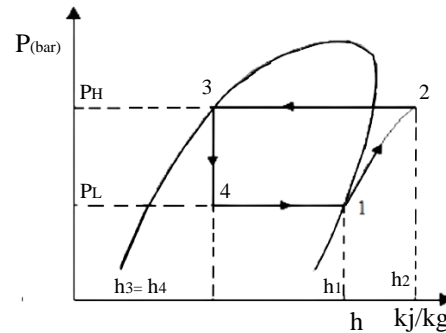

Figure. 3 P-H diagram of simple vapor compression refrigeration

1 – 2 Low-pressure liquid refrigerants

In the evaporator absorbs heat from its surroundings, usually air, water or some other process liquid. During this process it changes its state from a liquid to a gas, and at the evaporator exit is slightly superheated.

2 – 3 The superheated vapor

Enters the compressor where its pressure is raised. The temperature will also increase, because a proportion of the energy put into the compression process is transferred to the refrigerant.

3 – 4 The high pressure superheated gas

Passes from the compressor into the condenser. The initial part of the cooling process (3-3a) superheats the gas before it is then turned back into liquid (3a-3b). The cooling for this process is usually achieved by using air or water. A further reduction in temperature happens in the pipe work and liquid receiver (3b - 4), so that the refrigerant liquid is sub-cooled as it enters the expansion device.

4 - 1 The high-pressure sub-cooled liquid

Passes through the expansion device, which both reduces its pressure and controls the flow into the evaporator.

4.4 SIMPLE VAPOR COMPRESSION REFRIGERATION CYCLE

It is shown on T-S at point 1, let T_1 , P_1 , and S_1 be the properties of vapor refrigerant. the four processes of the cycle are as follows:

1. **Compression process:** The vapor refrigerant at low pressure P_1 and temperature T_1 is compressed isentropically to dry saturated vapor as shown by the vertical line 1-2 on T-s diagram and by the curve 1-2 on p-h diagram. The pressure and temperature rise from 1 to 2. The work done during isentropic compression is given by:

$$W = h_2 - h_1$$

Condensing process: The high pressure and temperature vapor refrigerant from the compressor is passed through the condenser where it is completely condensed at constant pressure P_2 and temperature T_2 . The vapor refrigerant is changed into liquid refrigerant. The refrigerant while passing through the condenser, gives its latent heat to the surrounding condensing medium.

2. **Expansion process:** The liquid refrigerant at pressure $P_3 = P_2$ expanded by throttling process through the expansion valve to a low pressure $P_4 = P_1$ and temperature $T_4 = T_1$. Some of the liquid refrigerant evaporates as it passes through expansion valve, but the greater portion is vaporized in the evaporator. During the throttling process no heat is absorbed or rejected by the liquid refrigerant.
3. **Vaporizing process:** The liquid vapor mixture of the refrigerant at pressure $P_4 = P_1$ and temperature $T_4 = T_1$ is evaporated and changed into vapor refrigerant at constant pressure and temperature. During evaporation, the liquid vapor refrigerant absorbs its latent heat of vaporization from medium (air, water or brine) which is to be cooled. The heat absorbed or extracted by the liquid vapor refrigerant during evaporation is given by:

$$RE = h^1 - h^4 = h^1 - hf$$

Where hf_3 is sensible heat at T_3 (enthalpy of liquid refrigerant leaving the condenser). The coefficient of performance is ratio of refrigerating effect to the work done.

$$C.O.P = \frac{(h_1 - h_4)}{(h_1 - hf_3)} = \frac{(h_1 - hf_3)}{(h_2 - h_1)}$$

4.5 TYPES OF REFRIGERANTS USED IN VAPOUR COMPRESSION SYSTEMS

A variety of refrigerants are used in vapor compression systems. The required cooling temperature largely determines the choice of fluid. Commonly used refrigerants are in the family of chlorinated fluorocarbons (CFCs, also called Freons): R-11, R-12, R-21, R-22, R-502, HFC 134a.

The properties of these refrigerants are summarized in Table 1 and the performance of these refrigerants is given in Table 2 below.

Refrigerant	Boiling Point (°C)	Freezing Point (°C)	Vapor Pressure (kPa)	Vapor Volume (m^3/kg)	Enthalpy	
					Liquid Kj/kg	Vapor Kj/KG
R-11	-23.82	-111.0	25.73	0.61170	191.40	385.43
R-12	-29.79	-158.0	219.28	0.07702	190.72	347.96
R-22	-40.76	-160.0	354.74	0.06513	188.55	400.83
R-502	-45.40	---	414.30	0.04234	188.87	342.31
R-7 (Ammonia)	-33.30	-77.7	289.93	0.41949	808.71	487.76

Table. 1 Properties of commonly used refrigerants

Refrigerant	Evaporating Press (kPa)	Condensing Press (kPa)	Pressure Ratio	Vapor Enthalpy (kJ/kg)	C.O.P Carnot
R-11	20.4	125.5	6.15	155.4	5.03
R-12	182.7	744.6	4.04	116.3	4.70
R-22	259.8	1192.1	4.03	162.8	4.66
R-502	349.6	1308.6	3.74	106.2	4.37
R-717	236.5	1166.5	4.93	103.4	4.78

Table. 2 Performance of commonly used refrigerants

4.6 VAPOR COMPRESSION CYCLE COMPONENT

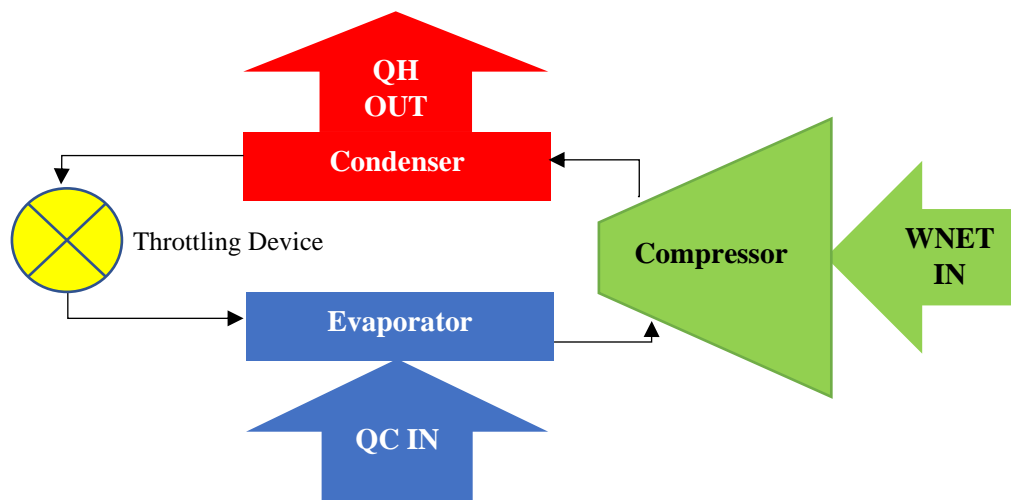

Figure. 4 Vapor Compression Cycle Component

Chapter 5

5.1 REFRIGERATION AND SECOND LAW OF THERMODYNAMICS

Refrigeration is the removal of heat from a space at a temperature lower than the surrounding temperature. Due to the natural frequency of heat to flow from higher to lower temperature, the rushes to replace the heat removed. But a refrigerator rejects the heat that is entering into the system back to the atmosphere. Hence input of work is essential, according to second law of thermodynamics systems for pumping heat from lower to higher temperatures.

5.2 SECOND LAW OF THERMODYNAMICS

- According to 2nd law of thermodynamics complete conversion of a low-grade energy into high grade energy is impossible in a cycle.
- Work can be completely converted into heat but the complete conversion of heat into work is not possible. So, heat and work are not completely interchangeable forms of energy.
- Work is said to be a high-grade energy and heat a low-grade energy.

It is common sense that heat will not flow spontaneously from a body at lower temperature to a body at higher temperature. In order to transfer heat from lower temperature to higher temperature continuously (that is, to maintain the low temperature) a refrigeration system is needed which requires work input from external source. This is one of the principles of second law of thermodynamics, which is known as Clausius statement of the second law.

5.3 'CLAUSIUS' STATEMENT OF SECOND LAW

The statement by Clausius uses the concept of 'passage of heat'. As is usual in thermodynamic discussions, this means 'net transfer of energy as heat', and does not refer to contributory transfers one way and the other. Heat cannot spontaneously flow from cold regions to hot regions without external work being performed on the system, which is evident from ordinary experience of refrigeration, for example. In a refrigerator, heat is transferred from cold to hot, but only when forced by an external agent, the refrigeration system.

5.4 KELVIN-PLANCK STATEMENT OF SECOND LAW

It is impossible to construct a device (engine) operating in a cycle that will produce no effect other than extraction of heat from a single reservoir and convert all of it into work. Mathematically, Kelvin-Planck statement can be written as: $\text{cycle} \leq 0W$ (for a single reservoir)

5.5 REFRIGERANTS

The thermodynamic efficiency of refrigeration system mainly depends on its operating temperatures. However, important practical issues such as system design, size, initial and operating costs, safety, and serviceability etc. depend very much on the type of the refrigerant selected for given application. Due to several environmental issues such as ozone layer depletion and global warming and their relation to the refrigerants used, the selection of suitable refrigerant has become one of the important issues in recent times.

Replacement of an existing refrigerant by a completely new refrigerant, for whatever reason, is an expensive proposition as it may call for several changes in the design and manufacturing of refrigeration systems. Hence it is very important to understand the issues related to the selection and the use of refrigerants. In principle, any fluid can be used as a refrigerant in vapor compression refrigeration systems only.

Chapter 6

6.1 REFRIGERANT SELECTION CRITERIA

Selection of refrigeration for a particular application is based on the following requirements

- Thermodynamic and thermo physical properties
- Environmental and safety properties, and
- Economics

6.2 THERMODYNAMICS AND THERMO PHYSICAL PROPERTIES

The requirements are:

- **Suction pressure:** At a given evaporated temperature, the saturation pressure should be above atmospheric for prevention of air or moisture ingress into the system and ease of leak detection.
- **Discharge pressure:** At a given condenser temperature, the discharge pressure should be as small as possible to allow light weight construction of compressor, condenser etc.
- **Pressure ratio:** Should be as small as possible for the high volumetric efficiency as low power consumption.
- **Latent and heat of vaporization:** Should be as large as large possible so that the required mass flow rate per unit cooling capacity will be small.

6.3 ENVIRONMENTAL AND SAFETY PROPERTIES

After thermodynamic and thermo physical properties, the environmental and safety properties are very important. In fact, at the present the environment friendliness of the refrigerant is a major factor in deciding the usefulness of a particular refrigerant. [8]

Chapter 7

7.1 LPG REFRIGERATION

In Bangladesh, more than 80% of the refrigerator utilizes HFC 134a as refrigerant, due to its excellent thermodynamic and thermo physical properties. But HFC 134a has a high global warming potential (GWP) of 1300. [9]. There is a need to evaluate various refrigerant options considering the existing refrigerators in the field and for the future market. CFCs are principally destroyed by ultraviolet radiations in the stratosphere; the chlorine released in the high stratosphere catalyzes the decomposition of ozone to oxygen; and ultraviolet radiations penetrate to lower altitudes. The ozone impact of car air conditioners also cannot be ignored. Hydro fluorocarbons (HFC's) can be thought of as a replacement, but unfortunately the radiation properties of HFCs like R-134a make them powerful global warming agents. [10].

7.2 LIQUEFIED PETROLEUM GAS (LPG).

LPG is basically a mix of hydrocarbons with 3 (C₃ – propane) and 4 (C₄ – butane) carbon atoms, receiving its name from the fact that it can be liquefied by compression at room temperature. This product may be used as domestic fuel for cooking and heating. The fact that LPG can be liquefied at relatively low pressure facilitates the storage of large amounts using, in general, spherical tanks, known simply as spheres.

7.3 PHYSICAL PROPERTIES AND CHARACTERISTICS OF LPG

Properties	Propane	Butane	LPG (C ₃ :30% & C ₄ :70%)
Physical state at 15°C and 1 atm	Gas	Gas	Gas
Boiling Point at 1 atm (°C)	(-) 42.1	(-) 0.5	(-) 13
Freezing point (°C)	(-) 187.7	(-) 138.4	(-) 153
Critical Temperature (°C)	96.67	305.6	243
Critical Pressure (psia)	616.25	551	570
Auto-Ignition temperature in air at 1 atm (°C)	470	500	490
Color (appearance)	Colorless	Colorless	Colorless
Odor	Odorless	Odorless	Odorless
Toxicity	Non toxic	Non toxic	Non toxic
Reid Vapor Pressure (RVP) at 15.6°C (bars)	12	3.6	5-7
Liquid density at 15°C (kg/liter)	0.51	0.575	0.5550
Specific volume of liquid per Kg at 15 C (liter)	1.96	1.73	1.7990
Specific density at 15 C & 1 atm (kg/m ³)	1.55	2.48	2.20

Table. 3. Typical specification of LPG marketed by TOTALGAZ in Bangladesh

7.4 HAZARDS OF LPG

- LPG is approximately twice as heavy as air when in gas form and will tend to sink to the lowest possible level and may accumulate in cellars, pits, drains etc.
- LPG in liquid form can cause severe cold burns to the skin owing to its rapid vaporization.
- Vaporization can cool equipment so that it may be cold enough to cause cold burns.
- LPG forms a flammable mixture with air in concentrations of between 2% and 10%.
- It can, therefore, be a fire and explosion hazard if stored or used incorrectly.

7.5 PARTS OF LPG REFRIGERATOR

7.5.1 LPG Gas Cylinder

LPG is general creation of two gases chiefly Propane (C_3H_8) and Butane (C_4H_{10}), either put away independently or together as a blend in a chamber. These gases can be melted at an ordinary temperature by use of a weight increment. LPG is put away in a chamber at about 12.5 bars. LPG is utilized as a fuel for modern, plant, cooking, agrarian, warming and drying forms. LPG can be utilized as a fuel for cars.



Figure. 5. LPG Cylinder

7.5.2 Capillary Tube

The capillary tube is the commonly used throttling device in the domestic refrigeration. The capillary tube is a copper tube of very small internal diameter. It is of very long length and it is coiled to several turns so that it would occupy less space. The internal diameter of the capillary tube used for the refrigeration applications varies from 0.5 to 2.28 mm (0.020 to 0.09 inch). The capillary tube is shown in picture. The decrease in pressure of the refrigerant through the capillary depends on the diameter of capillary and the length of capillary. Smaller is the diameter and more is the length of capillary more is the drop in pressure of the refrigerant as it passes through the capillary tube.



Figure. 6. Capillary Tube

7.5.3 High Pressure Pipes

When there is a need of transferring gas at high pressure, the range of high-pressure pipes are used. It consists of a steel pipe with steel spheres fixed at both the terminals. These spheres are pressed against the seating of connecting hole with the help of two swiveling nipple and thus the gas leakage is prevented.



Figure. 7. High pressure pipes

7.5.4 High Pressure Gauge

There are numerous procedures for the estimation of weight and vacuums. Weight checks and vacuum checks are the instruments used to gauge weight. The most generally utilized mechanical measure is Bourdon type weight check. It is a solid, straightened metal cylinder twisted into a roundabout shape, a dial graduated in weight unit for example bar. Weight measure records the check a roundabout shape, a dial graduated in weight unit for example bar. Weight measure records the check weight which is the contrast between liquid weight and outside air weight. These checks are accessible in the various scopes of weight.



Figure. 8. Pressure gauges

7.5.5 Evaporator

The evaporator is likewise a significant segment of the refrigeration framework. The cooling impact is created by going the refrigerant through evaporator loop. The genuine cooling impact happens inside the evaporator in the refrigeration frameworks. The warmth is expelled from the substance by exchanging the warmth



Figure. 9. Evaporator

7.5.6 High Pressure Regulator

This type of regulator is used to send high pressure gas from the cylinders. High pressure regulators reduce high pressures to adequate levels allowing for proper pressure application functionality. As an example, our high-pressure gas regulators can accept a 6000-psi input and reduce it to a working range of 10 to 500 psi, depending on specific requirement needs.



Figure. 10. High Pressure Regulator

7.5.7 Digital Thermometer

A simple digital thermometer is the combination of a thermocouple, a battery-powered, dual-slope digital voltmeter to measure the thermocouple output, and an electronic display. This provides a low-noise digital output that can resolve temperature differences as small as 0.1°C.



Figure. 11. Digital Thermometer

7.5.8 Strainer

Strainer's purpose is to provide filtration of contaminants in air conditioning and refrigeration systems. They provide free flow with negligible pressure drop. Typically used in the liquid line, they protect the metering device from solid contaminants.



Figure. 12. Strainer

7.5.9 Gas Burner

A gas burner is a device that produces a controlled flame by mixing a fuel gas such as acetylene, natural gas, or propane with an oxidizer such as the ambient air or supplied oxygen, and allowing for ignition and combustion.



Figure. 13. Gas Burner

CONSTRUCTION AND WORKING PRINCIPLE OF LPG REFRIGERATOR

8.1 CONSTRUCTION OF LPG REFRIGERATOR

The LPG refrigerator is shown in the figure. We make the one box of the Thermo-coal sheet. The thermo-coal sheet size is 25mm used for the LPG refrigerator. The size of the evaporator is 355.6×304.8×304.8 mm³. We kept the thermo-coal sheet because the cold air cannot transfer from inside to outside of refrigerator. And the evaporator is wrapped totally with masking tape. The schematically diagram of the LPG refrigeration system is shown in below diagram. The gas cylinder is connected to high pressure regulator, which is connected to high pressure pipes. To the other end of the high-pressure pipes pressure gauge is connected. To another end a copper tube is connected which is connected to the strainer and then to the capillary tube. The capillary tube is fitted with evaporator. The evaporator coil end is connected to the stove by another high-pressure pipe. One pressure gauge is put between capillary tube and cylinder and another is put at the end of the evaporator.

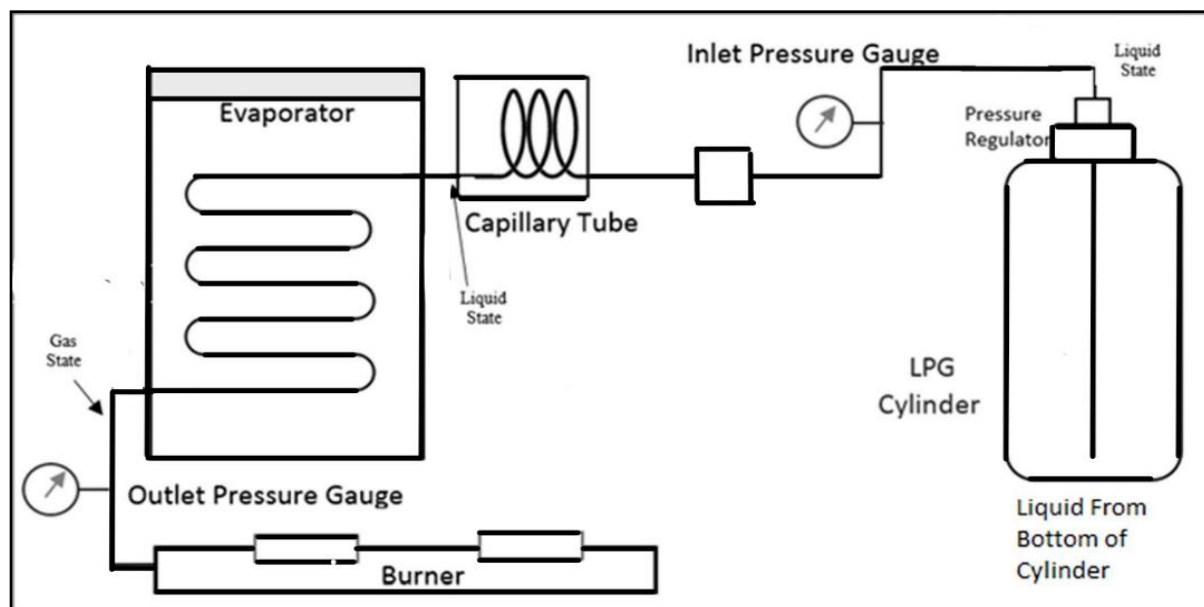

Figure. 14. Diagram of LPG Refrigeration System

8.2 WORKING OF LPG REFRIGERATOR:

The basic idea behind LPG refrigerator is to use the LPG to absorb heat. The simple mechanism of the LPG refrigeration working is shown in the figure below.

- LPG is stored in the LPG cylinder under high pressure. When the gas tank of regulators is opened then high-pressure LPG passes through the high-pressure pipe. This LPG is going by high pressure gas pipe to capillary tube.

- High pressure LPG is converted in low pressure at capillary tube with enthalpy remains constant.
- After capillary tube, low pressure LPG is passed through the evaporator. LPG is converted into low pressure and temperature vapor from and passes the evaporator which absorbs heat from the chamber. Thus, the chamber becomes cool down. Thus, we can achieve cooling effect in refrigerator.
- After passing through the evaporator low pressure LPG is passed through the pipe to burner. And we can use the low pressure of LPG in burning processes.

The LPG Refrigerator is work on the simple Vapor Compression Refrigeration system. [11]

The idea behind working of LPG refrigeration is to absorb heat from surrounding by using the evaporation of a LPG. The pressure of LPG which is stored in cylinder is at about 15 bar. We are lowering this pressure of LPG up to pressure 5bar by using capillary and so that cooling is done on surrounding by absorbing heat is entropically. Pressure of LPG in cylinder is high, when the regulator of gas tank is opened then high-pressure LPG passes through gas pipe. After that this high-pressure LPG goes in the capillary tube from high pressure pipe. In the capillary tube this high-pressure LPG is converted into low pressure and hence low temperature because of expansion of LPG gas in capillary tube. Thus, we can get refrigerating effect in refrigerator. After that the low-pressure LPG from evaporator is passed to the burner through high pressure pipe and we can use this low-pressure LPG for burning for further application. In this project we use recompressed LPG cylinder instead of compressor. In this way we can achieve refrigerating effect from this system. The actual setup and construction of LPG refrigeration system is shown in the following figure.



Figure. 15. LPG refrigeration and heating system

Chapter 9

DESIGN ANALYSIS

9.1 DESIGN ANALYSIS

There is main four parts in this system

1. Copper Tubes (For carrying LPG cylinder to filter before capillary)
2. Capillary tube
3. Valves (Gas supply control valves)
4. Evaporator

9.2 COPPER TUBES

Air-Conditioning and Refrigeration Systems—Copper is the preferred material for use with most refrigerants. Because of its good heat transfer capacity as well as corrosion resistance and cheaper in cost. As for all materials, the allowable internal pressure for any copper tube in service is based on the formula used in the American Society of Mechanical Engineers Code for Pressure Piping (ASME B31): [12]

$$P = 2S (t_{min} - C) / D_{max} - 0.8 (t_{min} - C)$$

Where:

P = allowable pressure, bar

S = maximum allowable stress in tension, bar

t_{min} = wall thickness (min.), in mm

D_{max} = outside diameter (max.), in mm

C = a constant for copper tube, because of copper's superior corrosion resistance, the B31 code permits the factor C to be zero. Thus, the formula becomes:

$$P = 2St_{min}/D_{ma} - 0.8t_{min}$$

According to the pressure 100 psi the tube outside diameter is become = 7 mm and the thickness of the tube is = 1.5 mm.

9.3 CAPILLARY TUBE

By considering the pressure and flow rate we select the capillary tube with internal diameter 0.78mm and length 3m. [13].

9.4 EVAPORATOR

We make the evaporator of the Thermo-coal sheet. The thermo-coal sheet size is 25mm used for the LPG refrigerator. The size of the evaporator is 355.6×304.8×304.8 mm³. We kept the thermo-coal sheet because the cold air cannot transfer from inside to outside of refrigerator. And the evaporator is wrapped totally with masking tape.

$$Q = m \cdot cp (T_o - T_i) = \epsilon \cdot m \cdot cp (T_s - T_i)$$

Where m is the mass flow rate, T_i , T_o and T_s are the inlet, outlet and surface temperatures, respectively,

$Q = h \times A_s (T_s - T_m)$ is the heat transfer rate, T_m is the mean flow temperature over the heat transfer area, A_s , and ϵ is the heat exchanger effectiveness, calculated from (Kays and London, 1984):

$$\epsilon = 1 - \exp(-NTU)$$

Where NTU is the number of transfer units. We have selected the plate and tube type evaporator because it provides a gentle type of evaporation with low residence time. It also preserves the food and other products from bacterial attack. It requires low installation cost.

Design calculations for evaporator

The evaporator has following dimensions: Length = 355.6 mm, Breadth = 304.8 mm and Height = 304.8 mm, the evaporator is made from six stainless steel sheets of 1mm thickness which enclose six thermocol sheets of 25 mm thickness. The areas for these sheets are as follows:

$$\text{Area}_1 = 304.8 \times 304.8 = 0.0929 \text{ m}^2,$$

$$\text{Area}_2 = 304.8 \times 355.6 = 0.1084 \text{ m}^2,$$

$$\text{Area}_3 = 304.8 \times 355.6 = 0.1084 \text{ m}^2,$$

$$\text{Area}_4 = 304.8 \times 304.8 = 0.0929 \text{ m}^2,$$

$$\text{Area}_5 = 304.8 \times 355.6 = 0.1084 \text{ m}^2,$$

$$\text{Area}_6 = 304.8 \times 355.6 = 0.1084 \text{ m}^2,$$

Thermal conductivity of stainless steel sheet $k_p = 14.4 \text{ W/m.k}$

Thermal conductivity of thermo coal $k_t = 0.02 \text{ W/m.k}$

Thickness of stainless-steel sheet = 1 mm

Thickness of thermo coal = 25 mm

Temperature of atmosphere = 31 °C = 304 K

Temperature of evaporator = 12.2 °C = 285.2 K

Chapter 10

DATA COLLECTION, ANALYSIS AND DISCUSSION

10.1 DATA COLLECTION

The gas cylinder in normal position (Upside up position)

The experiment of this project was done on September 7, 2022 at 8.11 p.m. and readings were taken under ten minute's intervals which are under as follow:

SL NO	Inlet Pressure (kg/cm ²)	Outlet Pressure (kg/cm ²)	Time (min)	Evaporator Temp. (°C)
1	5	0.9	10	31.6
2	5	0.9	20	29.3
3	5	0.8	30	28.1
4	5	0.7	40	25.7
5	5	0.5	50	21.9
6	5	0.4	60	18.8
7	5	0.4	70	16.4
8	5	0.3	80	14.8
9	5	0.2	90	12.2

Table. 4. Data Collection Normal Position

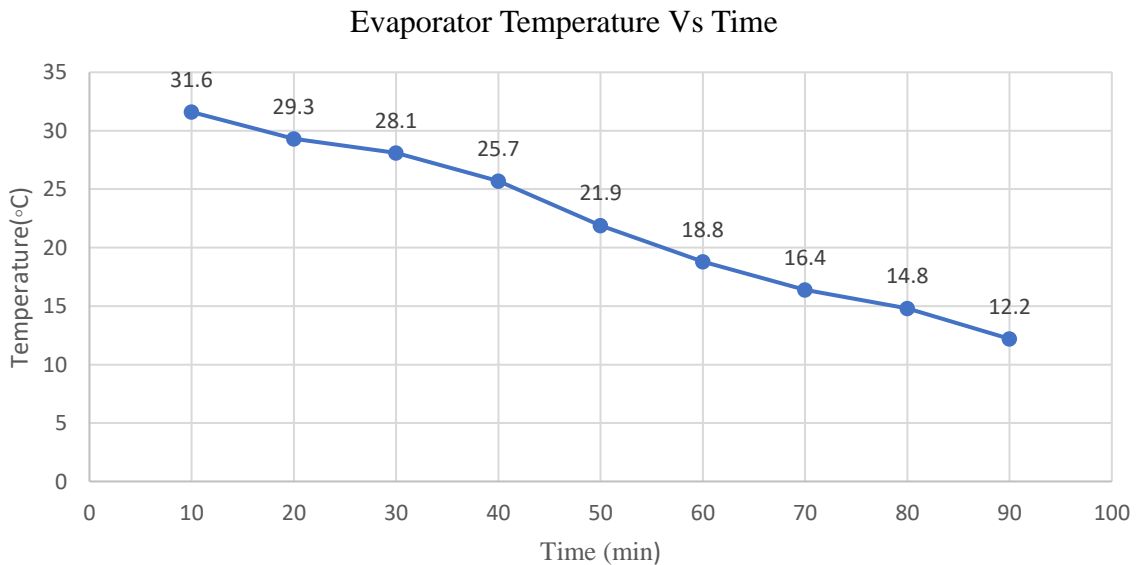

Figure. 16. Evaporator Temperature Vs Time

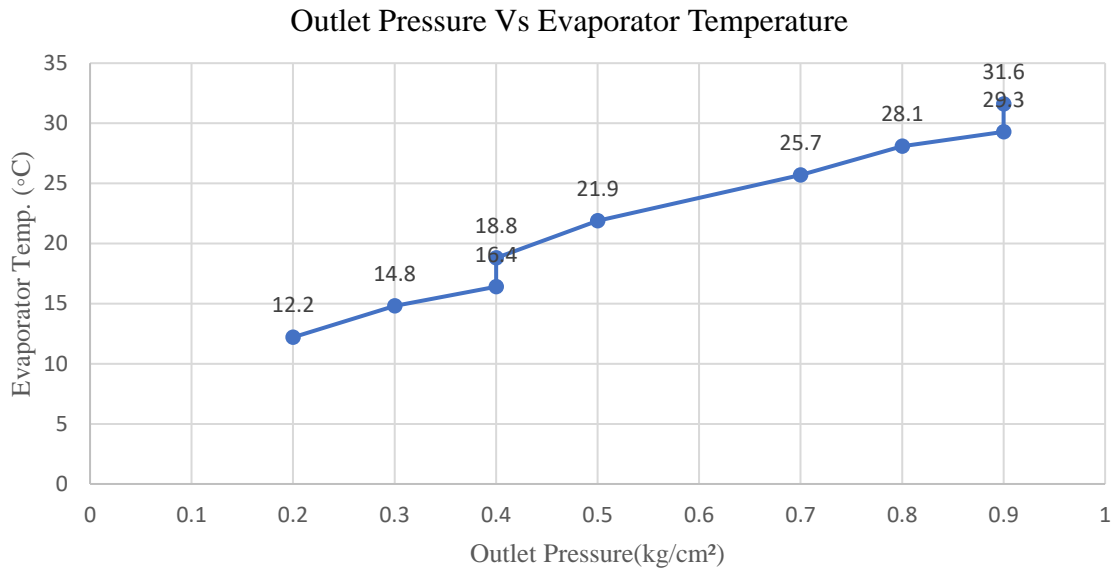

Figure. 17. Outlet Pressure Vs Evaporator

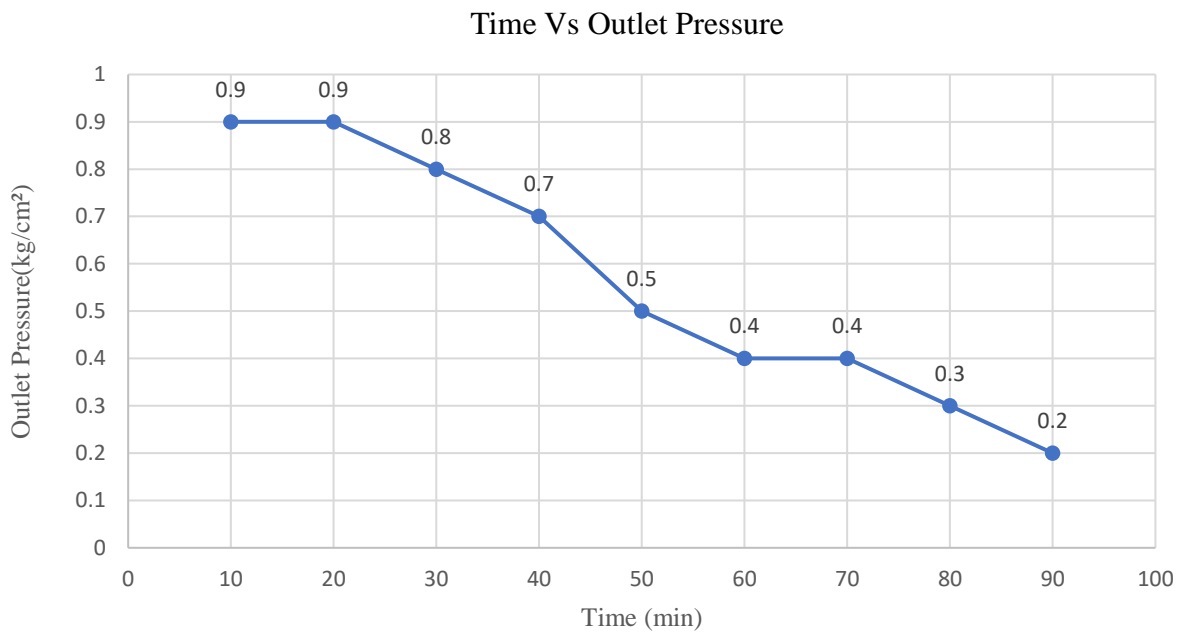

Figure. 18. Time vs Outlet Pressure

The gas cylinder in (Upside down position)

The experiment of this project was done on September 9, 2022 at 9.00 p.m. and readings were taken under one minute's intervals which are under as follow:

SL NO	Inlet Pressure (kg/cm ²)	Outlet Pressure (kg/cm ²)	Time (min)	Evaporator Temp. (°C)
1	5	2	1	28.7
2	5	2	2	28.0
3	5	2	3	25.9
4	5	2	4	24.1
5	5	2	5	22.2
6	5	2	6	20.6
7	5	2	7	19.2
8	5	2	8	18.6
9	5	2	9	18.2

Table. 5. Data Collection Upside Down Position

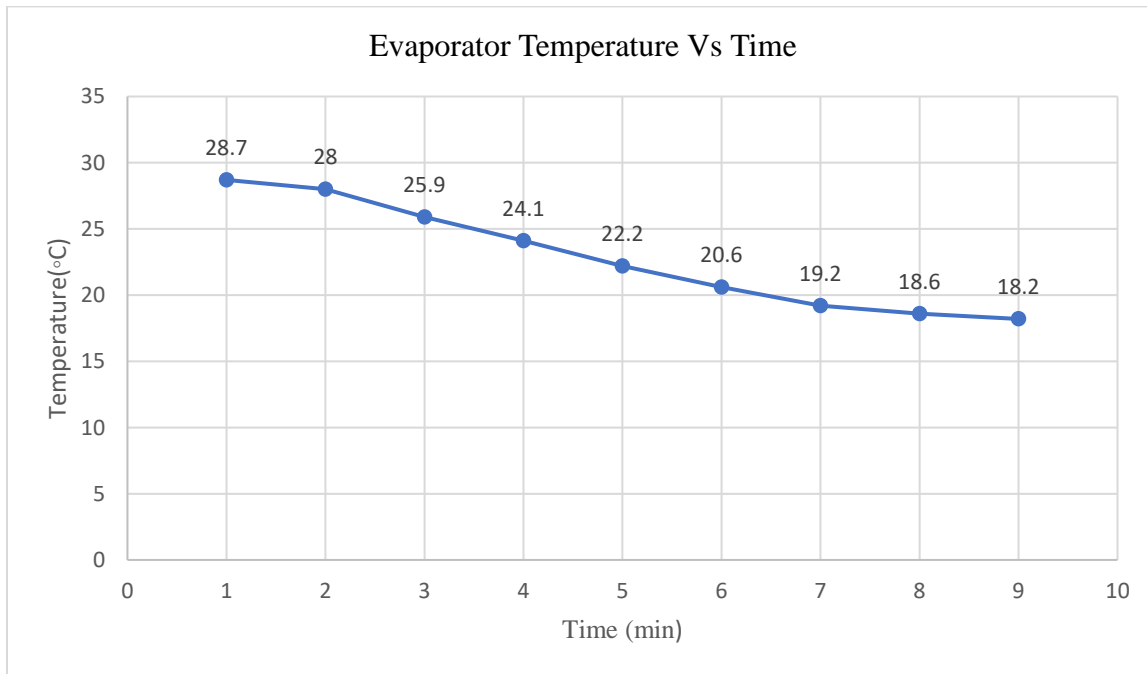

Figure. 19. Evaporator Temperature Vs Time When Gas cylinder is upside down

10.2 ANALYSIS

The properties of LPG at 5.525 bars are Enthalpy $h_1 = 430.3 \text{ kJ/kg}$

The properties of LPG at 1.22 bars are Enthalpy

- $h_f = 107.3 \text{ kJ/Kg}$
- $h_2 = 294.8 \text{ kJ/kg}$
- $h_g = 482.3 \text{ kJ/kg}$
- $h_3 = 562.46 \text{ kJ/kg}$

So, the refrigerating effect is,

$$RE = h_3 - h_2 = 562.46 - 294.8 = 267.66 \text{ kJ/kg}$$

For calculating the COP of the system, we required the work input. For work input we have a 12.6 Kg. LPG cylinder. Hence, input work is the amount of power required for filling 1 cylinder. From the PCRA energy audit report power required to refill 1 cylinder is 3.1354kWh.

Therefore, for filling 1 kg of LPG power required is, $= 3.1354/14.5 = 0.2162 \text{ kWh}$

We run the setup for 1.5 hr. for that power is $= 0.2162 \times 1000 / (9.45/10000) \times 5400 = 42.39 \text{ W}$

COP of the LPG Refrigeration System: $COP = RE/W = 267.66/42.39 = 6.3$

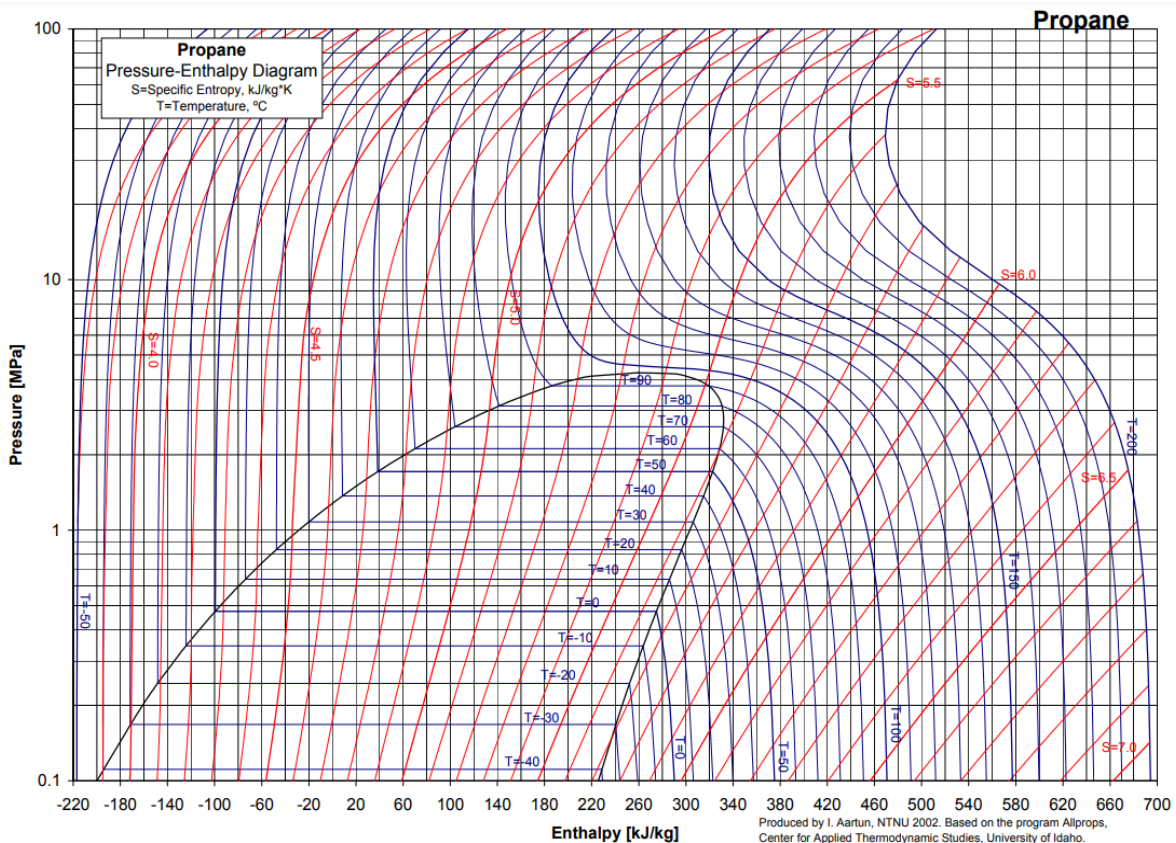

Figure. 20. Pressure-Enthalpy Diagram

10.3 COMPARE WITH DOMESTIC REFRIGERATOR

Cop of a domestic refrigerator is normally up to 2.95 which is lesser than the LPG refrigerator. Domestic refrigerator required high input power than LPG refrigerator. Also, there are more moving parts in domestic refrigerator and not eco-friendly. Domestic refrigerator requires more maintenance and operation is noisy.

10.3 DISCUSSION

10.3.1 ADVANTAGES:

- Use of LPG as a refrigerant also improves the overall efficiency of by 10 to 20%.
- The ozone depletion potential (ODP) of LPG is 0 and Global warming potential (GWP) is 8 which is significantly negligible as compare to other refrigerant.
- A part from environment friendly, use of LPG also gives us lot of cost advantages.
- There is 60% reduction in weight of the system due to higher density of LPG.
- This fridge works when electricity is off.
- The parts are effectively silent in operation.
- Running cost is zero
- Eliminates the compressor and condenser.

10.3.2 DISADVANTAGES:

- Efficiency is poor.
- Leakage of LPG causes the blast.
- Repairing and servicing of the system is difficult.
- System is very bulky

10.3.3APPLICATION:

- It can play an important role in restaurants where continuously cooling and heating is required.
- It can be used in chemical industries for refrigeration purpose.
- It can be useful in remote parts where electricity is not available.
- It can be used in refineries where consumption of LPG is high.
- The system can universally be used in industrial central cooling and domestic refrigeration and air conditioning as well.
- It can be used in automobiles running on LPG or other Gaseous fuels for air conditioning.
- It can be useful in remotes parts where Electricity is not available.
- Cooling and storage of essentials in remote areas and in emergency vehicles, such as storage of essential bio-chemicals, injections, etc. in an ambulance, is easily possible.
- It can be used for zero cost air-conditioning of spaces like airports, shopping malls, etc. which have their own gas turbine power-plants.

Chapter 11

CONCLUSION AND RECOMMENDATION

11.1 CONCLUSION

The aim of the LPG refrigerator was to use LPG as a refrigerant and utilizing the energy of the high pressure in the cylinder for producing the refrigerating effect. We have the LPG at a pressure of 12.41 bar in Domestic 12.6 kg cylinder equipped with a high-pressure regulator and this pressure has reduced up to 1.41 bar with the help of capillary tube. But if we use a low-pressure regulator as is the practice in conventional domestic LPG gas stove, the pressure of LPG after the expansion device and before the burner would be different. So, we have calculated the refrigerating effect with the help of changes in properties of LPG (pressure, temperature, and enthalpy) before and after the evaporator using high pressure regulator and the amount of refrigerating effect is 323kJ/Kg. Since we don't have the actual amount of energy that will be consumed in producing 1 Kg of LPG in the refinery and were not available in any of the Energy Audit Report of Refinery, that's why we have taken the energy input from refilling plant only. For energy input we have taken the amount of energy required for refilling 1 Kg of LPG in the bottling plant (PCRA energy audit report, HPCL LPG bottling plant Dec. 2006.) is 0.216 kWh. With this energy input the COP of the LPG refrigerator is 6.3 and it is greater than the domestic refrigerator. But in the future scope the result may differ if energy input for 1Kg of LPG production, would be taken from the energy audit report of any refinery. This system is cheaper at initial as well as running cost. It does not require an external energy source to run the system and no moving part in the system. So, maintenance cost is also very low. This system is most suitable for hotel, industries, refinery, chemical industries where consumption of LPG is very high. LPG is an attractive and environmentally friendly alternative to CFCs used currently [14]. Mass flow rate increases with increase in capillary inner diameter and coil diameter whereas mass flow rate decreases with increase in length. It was observed that the COP of system increases with similar change in geometry of capillary tube.

But cylinder in the upside-down case after 10 minutes of running time the liquid propane come through the burner and we shut down the process. We didn't get any idea how liquid propane pass through capillary tube. So, cylinder upside down position is not suitable for current setup.

11.2 REFERENCE

1. McMullan JT (2002) Refrigeration and the environmental issues and the strategies for the future. *Int J Refrig* 25:89–99
2. Sarma KM (1998) Protection of ozone layer—a success story of UNEP. *Int J Link* 3(3):1–3
3. Global emissions of refrigerants HCFC-22 and HFC-134a: Unforeseen seasonal contributions Bin Xiang bxiang, Prabir K., Stephen A. Montzka,
4. Experimental Study Of Lpg And R134a Refrigerants In Vapor Compression Refrigeration T. O. Babarinde,^{1,*} O. S. Ohunakin,¹ D. S. Adelekan,¹ S. A. Aasa,² & S. O. Oyedepo¹. *International Journal of Energy for a Clean Environment* 15(2), 1–10 (2014)
5. “The possibility of using liquefied petroleum gas in domestic refrigeration systems”, (2011), 9(3), 347-354. Zainal Zakaria¹ & Zulaikhashahrum
6. Performance Evolution of Domestic Refrigerator Using LPG Cylinder”, *International Research Journal of Engineering and Technology* 3(4), 2586-2592 Mhaske M. S., Deshmukh
7. Environmentally friendly alternative to halogenated refrigerants” Source: “*International Journal of Greenhouse Gas Control*) M. Mohan raj
8. McMullan JT (2002) Refrigeration and the environmental issues and the strategies for the future. *Int J Refrig* 25:89–99
9. McMullan JT (2002) Refrigeration and the environmental issues and the strategies for the future. *Int J Refrig* 25:89–99
10. Source: Montzka SA, Reimann S, O'Doherty S, et al. (2011) Ozone-depleting substances (ODSs) and related chemicals. In: Ravishankara AR, Newman PA, Pyle JA, and Nohende Ajavon A-L (eds.). *Scientific Assessment of Ozone Depletion: 2010*. WMO Global Ozone Research and Monitoring Project – Report 52, 1.1-1.108.
11. Kılıç B (2012) Exergy analysis of vapor compression refrigeration cycle with two-stage and intercooler. *Heat Mass Transfer* 48(7):1207–1217
12. Shank K. Wang, “*Handbook of air conditioning and refrigeration*” page no. 11.14 chapter 11.
13. Arora, “*Refrigeration and Air conditioning*”, capillary tube design (2010) 311-317.
14. Zainal Zakaria and Zulaikha Shahrin “The possibility of using liquefied petroleum gas in domestic refrigeration system” *International Journal of Research and Reviews in Applied Science (IJRRAS)*, December 2011, Volume9
15. Gill J, Singh J (2017) Experimental analysis of R134a/LPG as replacement of R134a in a vapor-compression refrigeration system. *Int J Air Cond Refrig* 25(02):1750015