

# FABRICATION OF PIPE BENDING MACHINE

A thesis report was submitted to the department of mechanical engineering for the partial fulfilment of the degree of Bachelor of Science in Mechanical Engineering.

A Thesis By

Student Name	Student ID
Md. Al-Amin Khalifa	BME1803016515
Amrita Sarker	BME1803016510
Md. Rakibul Islam	BME1803016513
Al Rakib	BME1803016509
Md. Borahan Uddin Neshat	BME1803016497

.....

Supervisor

**Md. Minhaz Uddin**

Lecturer of Mechanical Engineering



DEPARTMENT OF MECHANICAL ENGINEERING

SONARGAON UNIVERSITY (SU)

Dhaka, Bangladesh

14<sup>th</sup> SEPTEMBER 2022

# APPROVAL

This is to certify that the project on "**Fabrication Of Pipe Bending Machine**" By Full Name: Md. Al-Amin Khalifa (ID No: BME1803016515), Full Name: Amrita Sarker (ID No: BME1803016510), Full Name: Md. Rakibul Islam (ID No: BME1803016513), Full Name: Al Rakib (ID No: BME1803016509), Md. Borahan Uddin Neshat (ID No: BME1803016497), has been carried out under our supervision. The project has been carried out in part to the requirements of the degree of Bachelor of Science (B.Sc.) in Mechanical Engineering in the year 2022 and has been approved as to its style and contents.

.....

**Md. Minhaz Uddin**

Lecturer of Mechanical Engineering

Sonargaon University (SU)

# DECLARATION

We, hereby, declare that the work presented in this project is the outcome of the investigation and research work performed by us under the supervision of **Md. Minhaz Uddin**, Lecturer, Department of Mechanical Engineering, Sonargaon University (SU). We also declare that no part of this project and thesis has been or is being submitted elsewhere for the award of any degree.

Student Name:	Student ID
Md. Al-Amin Khalifa	BME1803016515
Amrita Sarker	BME1803016510
Md. Rakibul Islam	BME1803016513
Al Rakib	BME1803016509
Md. Borahan Uddin Neshat	BME1803016497

# ACKNOWLEDGEMENT

First of all, we are grateful to Allah, the almighty for giving us the courage and enthusiasm to complete the thesis work. The authors express their gratitude to “**Md. Minhaz Uddin**” for his constant & meticulous supervision, valuable suggestion and encouragement to carry out this work. For all this, the authors acknowledge their sincere gratitude to him. We are also grateful to all our thesis & project working teams of SU for their help in the construction of the project work and for giving their valuable knowledge and time to completing the experiment. Finally, we would like to thank everybody who supported us in the completion of the thesis.

## **Authors,**

Md. Al-Amin Khalifa

Amrita Sarker

Md. Rakibul Islam

Al Rakib

Md. Borahan Uddin Neshat

## **ABSTRACT**

Pipe bending a current developing process is an available service in the present market; however, each pipe bender has a different mechanism with its pros and cons. The manually operated machine is portable and can be mounted in a workshop, as part of production machinery or construction site to aid pipes, rods and angle irons bending operations. So, as to enhance productivity and early completion of projects. Pipe bending machines have passed through many enhancements, developments, and augmentations over time. Choosing a different type of bending for a pipe plays a critical role in industries, instruments, and transporting of fluids. The main concern is the required bend angle on which this pipe will bend on. The following report will include a description of the usability of this machine. The critical parameters that should be accounted for in the pipe bending are bend radius and angle, pipe diameter, and thickness. Moreover, a prototype that satisfies the required constraints is manufactured and assembled. Being a manual pipe bending machine means no use of electricity is required, resulting in no power consumption. In addition, this machine is convenient, accessible and affordable.

# TABLE OF CONTENTS

SI No.		Page No.
1	Approval	I
2	Declaration	II
3	Acknowledgement	III
4	Abstract	IV
5	List of Figure	VII

<b>CHAPTER 1</b>	<b>INTRODUCTION</b>	<b>01-03</b>
1.1	Background	01
1.2	Objectives	03
1.3	Organization of this Paper	03
<b>CHAPTER 2</b>	<b>LITERATURE REVIEW</b>	<b>04-13</b>
2.1	Introduction	04
2.2	Comparative Study	04
2.3	Types of Banding Machine	07
2.3.1	Press Bending	07
2.3.2	Rotary Draw Bending	08
2.3.3	Mandrel Bending	08
2.3.4	3 Roll Bending	09
2.3.5	Bending Spring	09
2.3.6	Heat Induction Bending	10
2.4	Literature Review	10
2.5	Summary	13
<b>CHAPTER 3</b>	<b>METHODOLOGY</b>	<b>14-25</b>
3.1	Process of Project	14
3.2	System Block Diagram	14
3.3	Working Principle	15
3.4	Required Instrument	15

3.4.1	Worm Gear Set	15
3.4.2	MS Steel Box	19
3.4.3	Rounded 3 Spoke Hand Wheel	20
3.4.4	Pillow Block Bearing	22
3.4.5	Pulley Block U Shape	23
3.4.6	Pipe Bending Handel	25
<b>CHAPTER 4</b>	<b>RESULT &amp; DISCUSSION</b>	<b>27-28</b>
4.1	Result	27
4.2	Discussion	28
<b>CHAPTER 5</b>	<b>CONCLUSION</b>	<b>29</b>
5.1	Application	29
5.2	Future Scope of this Project	29
5.3	Conclusion	29
	<b>Reference</b>	<b>30</b>

## LIST OF FUGURE

<b>Figure No.</b>	<b>Figure Name</b>	<b>Page No.</b>
1.1	Bending Pipe	02
2.1	Block Diagram of Metal Bending Machine	05
2.2	Manual Roller Bending Machine	06
2.3	Press Bending System	07
2.4	Rotary Draw Bending	08
2.5	Mandrel Bending	08
2.6	Roll Bending	09
2.7	Bending Spring	09
2.8	Heat Induction Bending	10
2.9	Experimental Tube Bending	12
2.10	The Propose Bending Machine	13
3.1	Our System Block Diagram	14
3.2	Worm Gear Set Up	16
3.3	Worm Set Up Indication	18
3.4	MS Steel Box	18
3.5	Round 3 Spoke Hand Wheel	20
3.6	Pillow Block Bearing	22
3.7	Pulley Block U Shape	24
3.8	Pipe Bending Handel Mechanism	25
4.1	Complete Project Picture ( Front View)	27
4.2	Complete Project Picture ( Top View)	28



# Chapter 1 Introduction

## 1.1 Background

Roller bending machines are very much utilized worldwide in industries to perform different types of functions on metal sheets. The size of these machines is very much significant as compared to the other machines. These machines are involved many components that help bend the metal sheets. Bending of the metal sheets is necessary for different industries to make the different parts according to the given requirements. Metal structures are made up of different types of metal sheets and strips. These strips are made over roller bending machines. The metal sheet is placed between the roller, and through the rolling force of the rollers, it bends in the forward direction. The thickness of the sheet is also reduced through this machine. These machines required much effort in bending the metal strips.

In construction and metallic projects, different bending metal strips are used. Also, these machines consume a lot of energy and effort, for example, fuel or electricity, to bend the sheets. The primary purpose of this project is to reduce the operating cost and maintenance costs of the roller bending machine. Moreover, this manual machine is required less maintenance and is easy to handle. Also, the manual roller bending machines required no electricity to operate. So, the design of these projects is helpful for industries to minimize the cost of a specific project. The onset of the industrial revolution took place from the 17th century until the mid-18th. This revolution was the reason for the existence of functioning machines today. The main branch of this revolution is manufacturing since it allowed the use of machines that significantly made daily human tasks much more accessible. Cold bending has been around since 1800B.C; it slowly developed until the industrial revolution in the 1760s’.

Many types of bending are available nowadays. A pyramidal type was chosen with a three-roller bending setup because of its various capabilities with just two degrees of freedom. The goal is to improve this type of process using analytical geometry and empirical techniques to achieve an ameliorated design. There are many types of bending techniques present now, but every type has its advantages and disadvantages. The two

rollers on the bottom are used to fix the work piece in a horizontal direction, and the upper roller will apply a downward force. The upper roller is adjusted using a hydraulic jack; thus, the roller only moves in the vertical direction. When defining the current bend angle, this clamp is locked.

The bottom rollers start to rotate, thus making a bending force Figure 1 on the work piece, which will result in deforming the work piece hence achieving plastic deformation. The main advantages of this process are that this mechanism is straightforward and straightforward. It can remedy the work piece that has been deformed in a wrong way, such as skew (Bending Error), accurate, consistent, and convenient. However, the disadvantages of such a process are unusable scrap parts. It occurs mainly in vertical three roller bending [2], which means if the pipe is long, due to its weight (work piece weight) while being rolled, it will bend to a side and cause torsion. Moreover, it is a type of manufacturing inaccuracy of unwanted deformation or deflection.



Figure 1.1: Banding Pipe

Our revolutionary life and inventions depend heavily on rolling part bearings. They are used in nearly all rotary devices, assisting rotation and helping complex forces. If a rolling part bearing fails without being noticed and followed up on, it may have disastrous consequences for the system. We try to keep an eye on these critical components by measuring their temperature, noise, vibrations, and oil wears debris, among other things. Vibration signals have proved to be extremely useful for maintenance workers, not just in detecting the location of a fault but also in finding the source. Input from vibration signals has lately been used to provide observers with an understanding of the scale of the fault and, as a result, to estimate the bearing's usable remaining life. On the other hand, vibrations picked up by accelerometers must go through a series of rigorous processing steps to extract fault symptoms and identify and quantify fault size.

## 1.2 Objectives

We have some specific objectives for this project and they are pointed out below:

- To **Fabrication Of Pipe Bending Machines.**
- To implement of **Pipe Bending Machine.**
- To increase the accuracy of the product.
- To reduce time consumption.
- Less machine setup time is required.
- To study the system performance for future reference and improvement purposes.

## 1.3 Organization of this paper

This Project is organized as follows:

**Chapter 1 Introduction:**The first chapter contains the statement of the introduction, our background study for the project, the objectives of the study, the methodology used in the project and the project outline.

**Chapter 2 Background and Motivation:**The chapter two contains our literature review part.

**Chapter 3 Methodology:**Chapter three describes the theoretical model. Here we mainly discuss the proposed system architecture in detail with having block diagram, circuit diagram, project working principle, complete project image, project instrument cost analysis and discuss the Hardware and software development of our project etc.

**Chapter 4 Performance Evaluation:**Chapter four deals with the result and discussion and discuss our project's advantages and application.

**Chapter 5 Conclusion:**Chapter five is all about our project conclusion, limitations and future scope.

# Chapter 02 Literature Review

## 2.1 Introduction

In this section topics related to **Pipe Bending machines** are included. These provide a sampling of problems appropriate for the application of **Pipe Bending Machines**. The references are summarized below.

## 2.2 Comparative Study

During the roll bending operation, the sheet or pipe is passed through a series of rollers that progressively add pressure to the pipe, as developed by Prof. A.D.ZOPE. The radius of the pipe or layer changes as a result of this friction. This project aims to create a portable metal bending system. This unit bends sheets into curves and other forms of curvature. In comparison to other computers, this machine is tiny. It is ideal for on-the-go jobs. We are working on a manual metal bending system that uses a metal shaft, a hydraulic bottle jack, a pedestal bearing, and a brace. Instead of a complex architecture, this computer uses a primary kinematic device. It can be used by a small factory, fabrication shop, or small-scale industry, and is lightweight and portable.

A *bending machine* is a machine that is used to bend metal in a machine shop. For bending a pipe, there is no suitable small-scale bending unit. Steel is bent using a roller in a Metal Bending rig. The bent machine has three rollers. Pipe (square and circular) bending and sheet bending are two of the most popular products of metal bending machines. The board, plate, or pipe is passed through a series of rollers that progressively add pressure to the pipe during the roll bending operation. The radius of the pipe or layer changes as a result of this friction. Because of the different arrangements of the three rollers, the rolling process is usually done by a three-roll bending system, also known as a pyramid type. The procedure is divided into three steps:

- 1) The sheet or pipe must be properly positioned.
- 2) The central roller is lowered.
- 3) By repeating feed of pipe. (A.D.Zope, 2017)

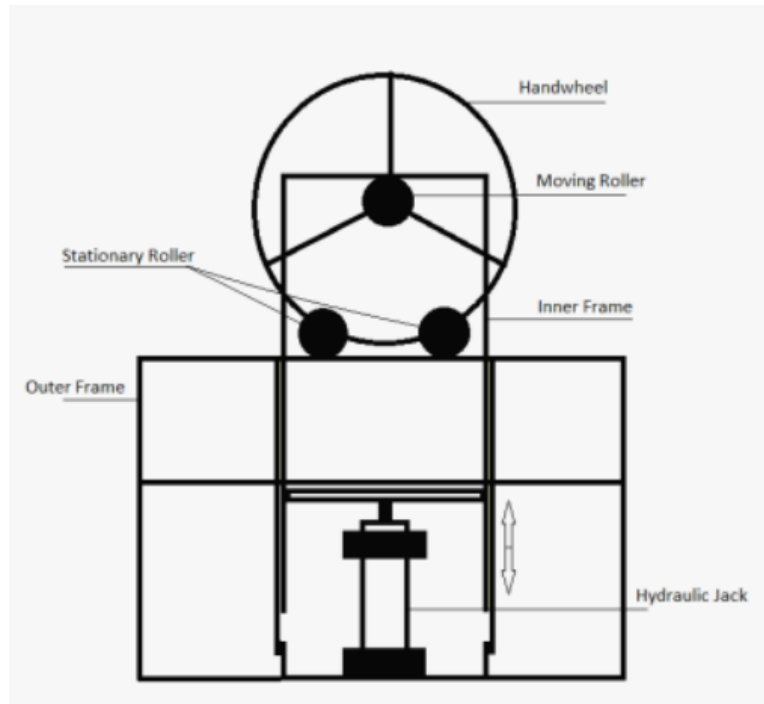

Figure 2.1: Block diagram of metal bending machine (A.D.Zope, 2017)

It is beneficial to the building industry and specific other sectors. Bending is a method of deforming metal by plastically deforming the material and altering its shape. The substance is strained past its yield strength but not yet to its maximum tensile strength. Sheet metal and metal bars can all be bent with a roll. If a bar is used, the cross-section is considered uniform but not strictly rectangular, as long as there are no overhanging contours. Between the rollers, the bar section would take on the form of a cubic polynomial, which approximates a circular arc. The rollers are then rotated, which causes the bar to rotate as well. As a segment of the bar leaves the region between the rollers, the elastic deformation is reversed. To obtain the desired radius, this "spring-back" must be compensated when changing the middle roller. The sum of spring back is determined by the material's elastic conformity (inverse of stiffness) to its ductility. Steel bars are more difficult to fold into an arc than aluminium bars. Pumping may be done with the aid of a handle on the jack. The oil inside the cylinder assists the piston rod in moving upwards as the handle is pressed once. A roller is fixed to the piston rod's tip. A pipe is held within these arrangements for the bending phase. This breakthrough has made them more appealing and cost-effective. This prototype, titled "ROLL BENDING MACHINE," was

created in the hopes of being very cost-effective and beneficial to construction and other industries. (Jayakumar, 2019) P. P. Khandare et al. built a project to design and construct a compact pipe bending system that could turn steel pipes into curves and other shapes. It was simple to transport and use at any time and in any place, requiring less human labour and requiring a less trained workforce. It can bend pipes with a thickness of up to 4-5 mm, but it is only suitable for use in a small workshop or welding shop. (Khandare, 2016)

This paper aims to create a roller bending machine used in a workshop to bend metal strips. This project aims to develop and construct a mobile roller bending system. Metal strips are bent into curves and other curvature forms using this unit. The machine's scale makes it ideal for mobile work. It is entirely made of titanium. Furthermore, it is simple to transport and use at any time and in any place.



Figure 2.2: Manual Roller Bending Machine (Pachange, 2019)

This computer requires less human effort and requires less ability to run. We are developing a manually controlled roller bending system through the use of rollers, chain sprockets, and assistance. The bending system for rollers is run by hand. As a result, our goal is to improve precision at a low cost without sacrificing bending efficiency. Instead of a complex architecture, this computer uses a primary kinematic device. It may be used by a small workshop or fabrication shop due to its portability. A *bending machine* is a machine shop instrument that is used to bend metal. (Pachange, 2019)

### 2.3 Types of Banding Machine

There are many kinds of bending mechanisms in our world. Some of these banding machines are given below -

#### 2.3.1 Press Bending

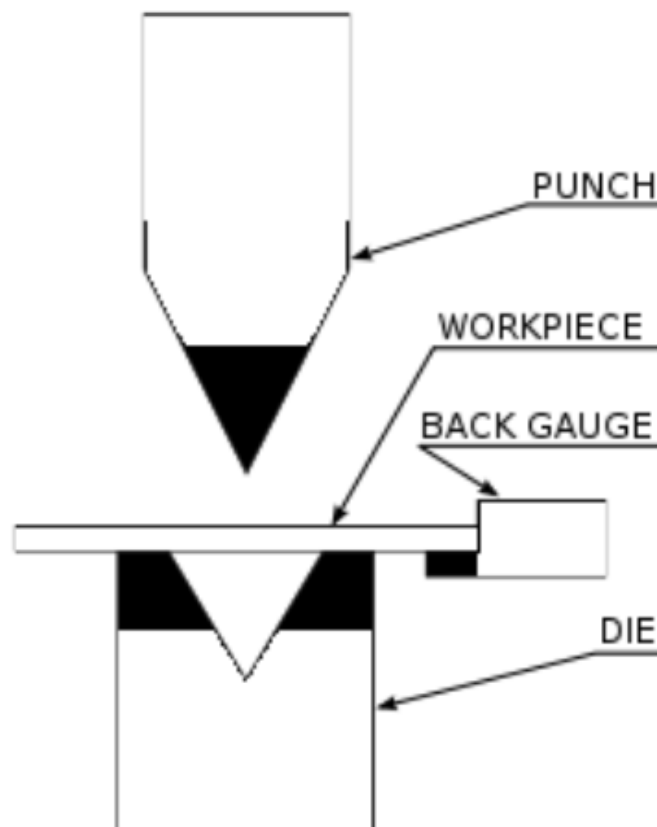

Figure 2.3: Press Bending System

### 2.3.2 Rotary Draw Bending

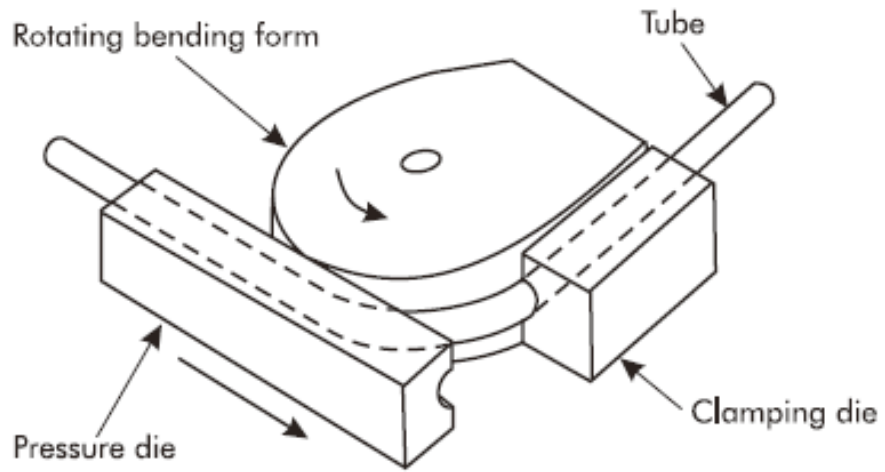

Figure 2.4: Rotary Draw Bending

### 2.3.3 Mandrel bending



Figure 2.5: Mandrel Bending



### 2.3.4 3 Roll Bending

## 3 Roll Bending

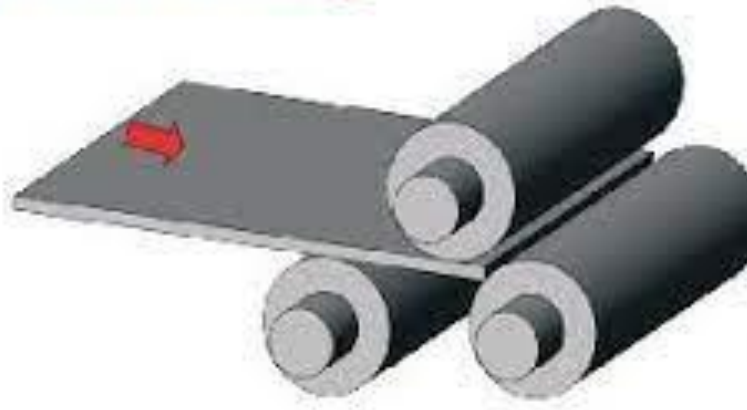

Figure 2.6: Roll Bending

### 2.3.5 Bending Springs



Figure 2.7: Bending Springs

### 2.3.6 Heat Induction Bending

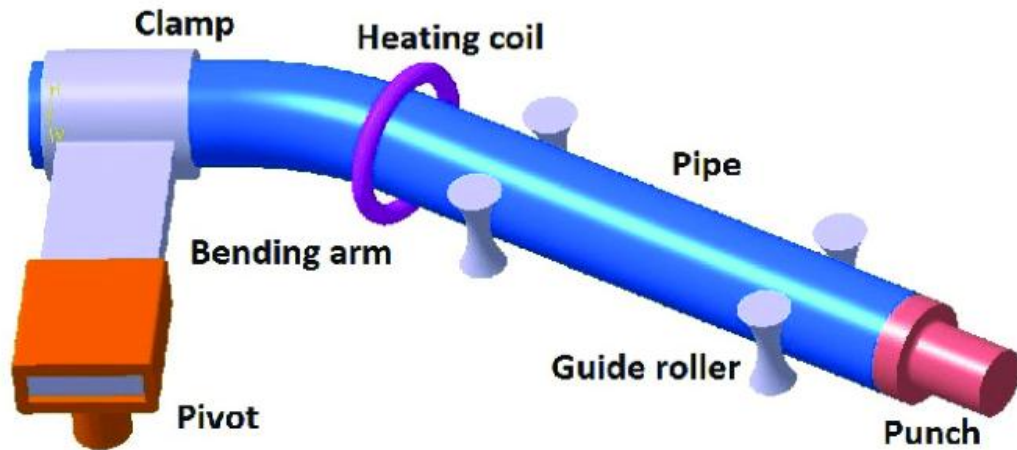

Figure 2.8: Heat Induction Bending

## 2.4 Literature Review

Akbar Khan, Pravin Ghule, Anjit Shingar [1] (2011) "Journal of Industrial Engineering and its application" is published a mechanical model of symmetrical three-roller setting round process to find this way we can conclude that successfully we manufacture the low cost less effort required manually operates pipe bending machine is developed.

A.D Zope, R R Deshmukh, D.R mete [2] published in ISOR Journal of mechanical and civil Engg IOSR-JMCE to determine a to develop portable bending machine used for bent sheet into a curve shape. This machine is very small in size compared to other pipe bending machines. These machines are used to bend up to 8mm thick sheets. These 3 rollers are used for bending machines in a paper on the design and development of metal bending machines.

Jun Zhao Gaochao Yu Rui Ma [3] "Journal Of Material Processing Technology" discovered a mechanical model of symmetrical three-roller setting round process to find the mechanical model of these static bending deformations in the symmetrical three-roller setting round process is established, and the quantities relationship between the upper roller load, bending curvature of each micro-pipe-wall element and the

reduction are predicted. This not only lays a theoretic foundation for the development of the three-roller special setting round machine and control strategies, but also provides an idea for resolving many degrees of statically in determining problems with an elastic-plastic deformation.

K. Chudasama & HK Raval[4] (2013) “journal of the manufacturing process” is published bending force prediction roll bending during 3 roller conical bending process. To determine As the thickness of the plate increase the bending force increase which is an obvious fact that it will require a higher force for bending the thicker plate. As the rate of decrease in bending force increases as the radius increase, as has been observed. It is also observed that as the bend radius increase, the required bending force decrease for the same value of the coefficient of friction and the thickness of the plate. It suggests that a bend with a larger radius can be produced with less effort.

Dhaval T sutar, Kiran R Malvi, Denesh k Patel[5] of “journal of research in mechanical Engg& technology” to determine a to Determine Final working of Rolling Pipe Bending machine. The current Machine Design Has The following feature.

- 1) Accuracy of operation
- 2) Cost & strength. The material used for the component of the machine is mild steel. Which is of considerable strength as well as of low cost.

Mohan Krishna SA[6] (2014) “study of the hydraulic and pneumatic bending machine” concluded that this work has provided an excellent opportunity and experience, to use limited knowledge. It has gained a lot of practical knowledge regarding, planning, purchasing, assembling and machining while doing this project work. The work is a good solution to bridge the gates between institutions and industries. The work is completed the work with the limited time successfully.

H. Yang et al. created a pipe bending system with many parts and a wide variety of shapes and sizes. From a material and structural standpoint, bent tube parts meet the growing need for lightweight and high-strength components. Tube bending has been one of the essential engineering innovations for the development of lightweight products.

Advances in exploring the typical problems in tube bending are summarized by studying bending characteristics and various defects, including wrinkling instability at the intrados, wall thinning (cracking) at the extrados, springback phenomena, cross-section deformation, shaping limit, and process/tooling configuration. The benefits and disadvantages of specific recently established bending techniques are discussed. Finally, the growth developments and related obstacles for realizing precise and high-efficiency tube bending deformation are posed in light of the urgent requirements for high-performance complex bent tube components with difficult to deform and lightweight materials in aviation and aerospace sectors. (Hea, 2012)



Figure 2.9: Experimental bent tubes with large diameter (Hea, 2012)

Hiroyuki Goto and colleagues describe a new versatile bending machine and its implementations. The proposed computer employs a novel approach. Tubes are twisted by changing the relative direction of the mobile die as they are inserted into the fixed and mobile dies. Also, the relative distance and direction between the mobile die and the tube determine the bending radius. The length of the fed conduit determines the bent angle. This shaping method has a significant benefit. A variation in the anticipated bending form will not necessitate a tooling device change. However, it will necessitate a new understanding of the active die's motion and the length of the fed tube. A 6-DOF Parallel Kinematic Mechanism (PKM) with a hydraulic servo drive controls the active die motions. The PKM is used to achieve a full motion over six axes and a high dynamic

motion of the bending machine. Designer interiors, universally manufactured goods, and car components are examples of where the bending machine can be used. These processes have previously been impossible to accomplish with a traditional bending system. (Goto, 2008)

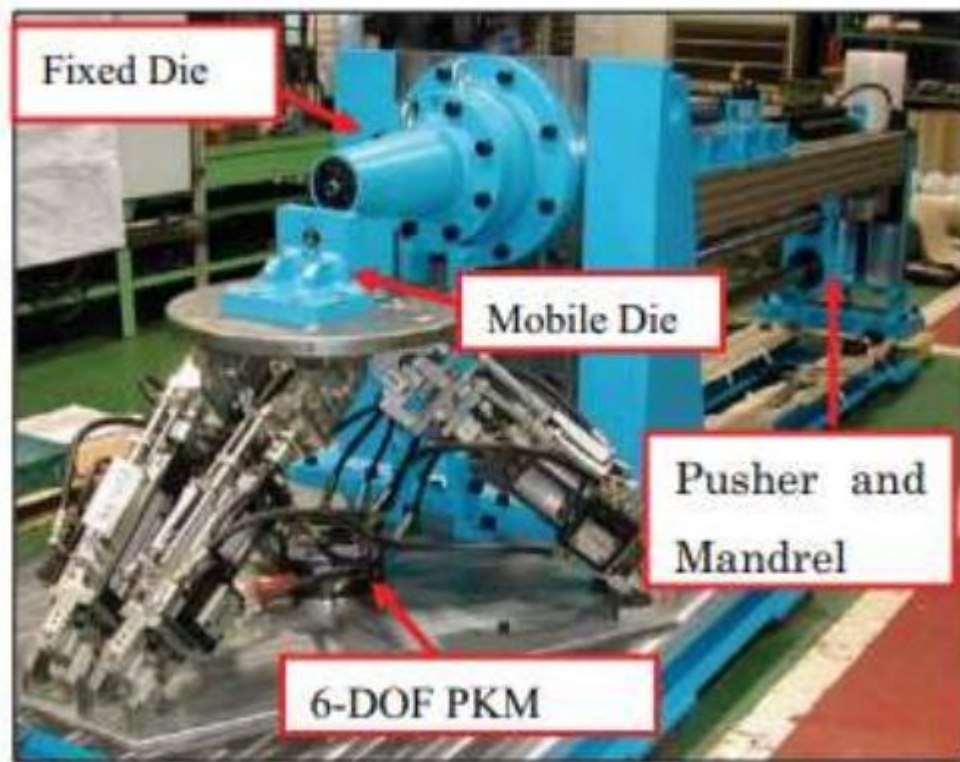

Figure 2.10: The Proposed Bending Machine (Goto, 2008)

A bicycle integrated pipe bending system was engineered and developed by H. A. Hussain. The unit has a chain drive and a compound gear train for bending steel pipe with an outside diameter of 25 mm and a thickness of 2 mm. The bending mechanism's kinematic synthesis is completed. It was decided to do a dimensional analysis. The deduced relationships forecast the efficiency of the bicycle integrated pipe bending mechanism, and all of the parameters must be adjusted to achieve the best machine performance. (Hussain, 2014)

## 2.5 Summary

We try to do this project by reading the above literature, and we have been able to make our project successful by reducing the mistakes of last year's project.

# Chapter 03 Methodology

## 3.1 Process of Project

Our methodologies for the project:

- Creating an idea for the fabrication of a **Pipe Bending Machine**. And designing a block diagram & structural diagram to know which components we need to construct it.
- Collecting all the components of our system.
- Setting up all the components and assembling all the blocks on a board and running the system & for checking purposes.

## 3.2 System Block Diagram

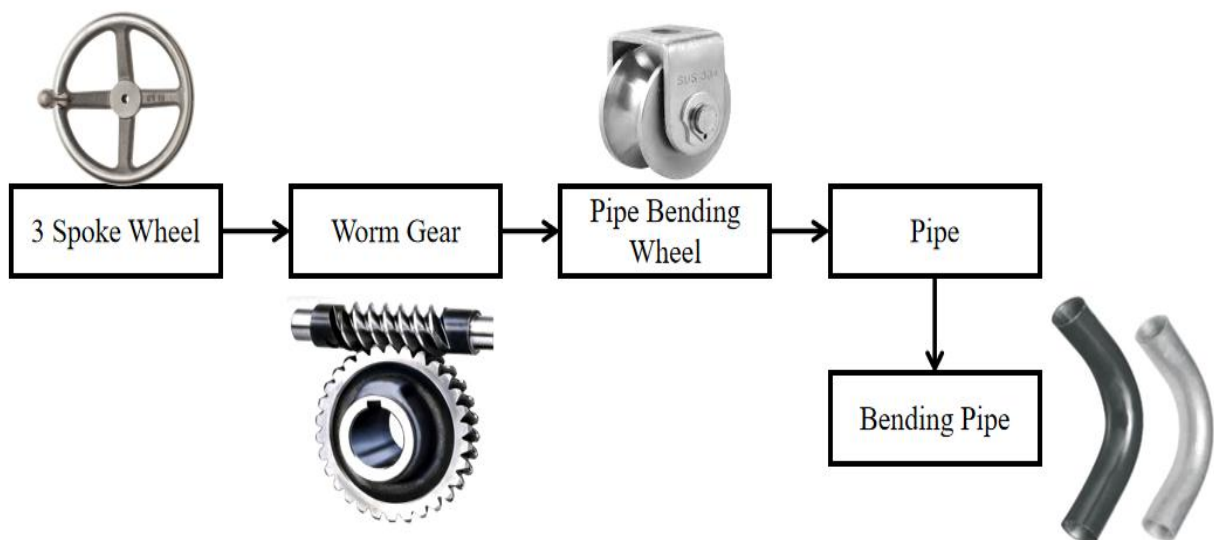

Figure 3.1: Our System Block Diagram

### **3.3 Working Principle**

In the tube rolling or pipe banding industry, a wide range of power and hand-operated machines are used. As the industry is a large and growing industry different types of machines are used for different operations. Our project the pipe banding machine is very simple in operation by using gear arrangement. This machine produces round pipes of different diameters and lengths. This machine can be used in various fields. This machine consists of two spur gear which is coupled with a handle and connects the spur gear shaft with the rolling main shaft. This machine is simple in construction and working principles. The Bending Force is applied with the handle operated. Thus pipe is bent. For the desired diameter of the bending curve, the pulleys are changed or altered.

### **3.4 Required Instruments**

- Worm Gear Set
- MS Steel Box
- Round 3 Spoke Hand Wheel.
- Pillow Block Bearing
- Precision Shaft
- Steel Pulley Block u shape
- U-Shaped Guide Wheel

#### **3.4.1 Worm Gear Set**

A worm drive is a gear arrangement in which a worm (which is a gear in the form of a screw) meshes with a worm wheel (which is similar in appearance to a spur gear). The two elements are also called the worm screw and worm gear. The terminology is often confused by the imprecise use of the term worm gear to refer to the worm, the worm wheel, or the worm drive as a unit.



Figure 3.2: Worm Gear Set Up

The worm drive or "endless screw" was invented by Archytas of Terentum, Apollonius of Perga, or Archimedes, the last one being the most probable author. The worm drive later appeared in the Indian subcontinent, for use in roller cotton gins, during the Delhi Sultanate in the thirteenth or fourteenth centuries.

A gearbox designed using a worm and worm wheel is considerably smaller than one made from plain spur gear and has its drive axes at  $90^\circ$  to each other. With a single-start worm, for each  $360^\circ$  turn of the worm, the worm wheel advances by only one tooth. Therefore, regardless of the worm's size (sensible engineering limits notwithstanding), the gear ratio is the "size of the worm wheel - to - 1". Given a single-start worm, a 20-tooth worm wheel reduces the speed by the ratio of 20:1. With spur gears, a gear of 12 teeth must match with a 240-tooth gear to achieve the same 20:1 ratio. Therefore, if the diametrical pitch (DP) of each gear is the same, then, in terms of the physical size of the 240 tooth gear to that of the 20 tooth gear, the worm arrangement is considerably smaller in volume.



## **Types**

Three different types of gear are used in a worm drive. The first is non-throated worm drives. These don't have a throat or groove machined around the circumference of either the worm or worm wheel. The second is single-throated worm drives, in which the worm wheel is throated. The final type is double-throated worm drives, which have both gears throated. This type of gearing can support the highest loading. An enveloping (hourglass) worm has one or more teeth and increases in diameter from its middle portion toward both ends. Double-enveloping worm gearing comprises enveloping worms mated with fully enveloping worm wheels. It is also known as globoid worm gearing.

Unlike with ordinary gear trains, the direction of transmission (input shaft vs output shaft) is not reversible when using large reduction ratios. This is due to the greater friction involved between the worm and worm wheel and is especially prevalent when a single-start (one-spiral) worm is used. This can be an advantage when it is desired to eliminate any possibility of the output driving the input. If a multi-start worm (multiple spirals) is used, then the ratio reduces accordingly, and the braking effect of a worm and worm wheel may need to be discounted, as the wheel may be able to drive the worm. Worm drive configurations in which the wheel cannot drive the worm are called self-locking. Whether a worm drive is self-locking depends on the lead angle, the pressure angle, and the coefficient of friction.

## **Application**

In early 20th century automobiles before the introduction of power steering, the effect of a flat or blowout on one of the front wheels tended to pull the steering mechanism toward the side with the flat tire. The use of a worm drive reduced this effect. Further worm drive development led to recirculating ball bearings to reduce frictional forces, which transmitted some steering force to the wheel. This aids vehicle control, and reduces wear that could cause difficulties in steering precision. Worm drives are a compact means of substantially decreasing speed and increasing torque. Small electric motors are generally high-speed and low-torque; the addition of a worm drive increases the range of applications that it may be suitable for, especially when the worm drive's compactness is considered.

Worm drives are used in presses, rolling mills, conveying engineering, mining industry machines, on rudders, and circular saws. In addition, milling heads and rotary tables are positioned using high-precision duplex worm drives with adjustable backlash. Worm drives are used on many lift/elevator and escalator-drive applications, due to their compact size and their non-reversibility. In the era of sailing ships, the introduction of a worm drive to control the rudder was a significant advance. Before its introduction, a rope drum drive controlled the rudder. Rough seas could apply substantial force to the rudder, often requiring several men to steer the vessel—some drives had two large-diameter wheels so that up to four crewmen could operate the rudder.

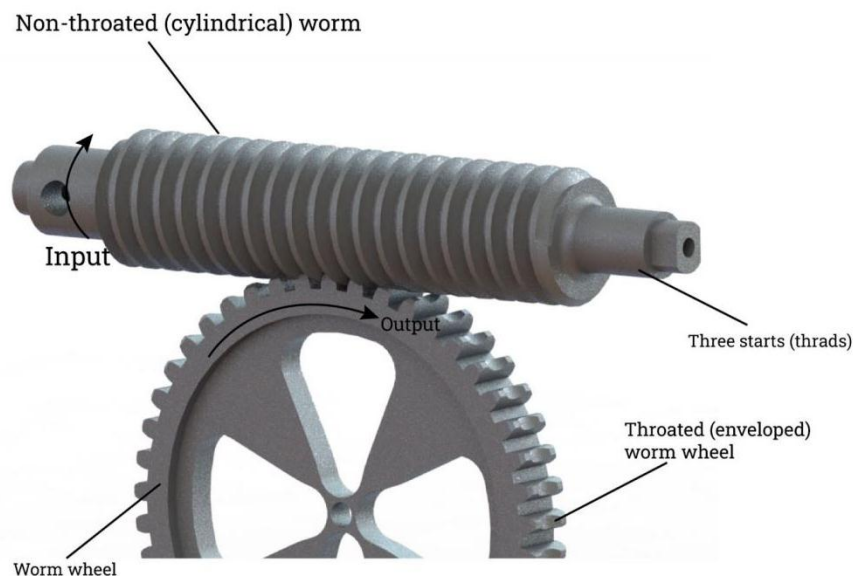

Figure 3.3: Worm Set Up Indication

Worm drives have been used in a few automotive rear-axle final drives (though not the differential itself). They took advantage of the location of the worm being at either the very top or very bottom of the differential crown wheel. In the 1910s, they were common on trucks; to gain the most clearance on muddy roads, the worm was placed on top. In the 1920s, the Stutz firm used them on its cars; to have a lower floor than its competitors, the worm was located on the bottom. An example circa 1960 was the Peugeot 404. The worm drive protects the vehicle against rollback. This ability has largely fallen from favour, due to the higher-than-necessary reduction ratios.

A more recent exception to this is the torsion differential, which uses worm wheels and planetary worms, in place of the bevel gearing of conventional open differentials. Torsion differentials are most prominently featured in the Humvee and some commercial Hummer vehicles, and as a centre differential in some all-wheel drive systems, such as Audi's Quattro. Very heavy trucks, such as those used to carry aggregates, often use a worm drive differential for strength. The worm drive is not as efficient as a hypoid gear, and such trucks invariably have a very large differential housing, with a correspondingly large volume of gear oil, to absorb and dissipate the heat created. Worm drives are used as the tuning mechanism for many musical instruments, including guitars, double basses, mandolins, bouzoukis, and many banjos (although most high-end banjos use planetary gears or friction pegs). A worm drive tuning device is called a machine head. Plastic worm drives are often used on small battery-operated electric motors, to provide an output with a lower angular velocity (fewer revolutions per minute) than that of the motor, which operates best at a fairly high speed. This motor-worm-drive system is often used in toys and other small electrical devices.

### 3.4.2 MS Steel Box

**Steel** is an alloy made up of iron with typically a few tenths of a percent of carbon to improve its strength and fracture resistance compared to other forms of iron. Many other elements may be present or added. Stainless steels that are corrosion- and oxidation-resistant typically need an additional 11% chromium. Iron is the base metal of steel.



Figure 3.4: MS Steel Box

Depending on the temperature, it can take two crystalline forms (allotropic forms): body-centered cubic and face-centered cubic. The interaction of the allotropes of iron with the alloying elements, primary carbon, gives steel and cast iron their range of unique properties. In pure iron, the crystal structure has relatively little resistance to the iron atoms slipping past one another, and so pure iron is quite ductile, or soft and easily formed. In steel, small amounts of carbon, other elements, and inclusions within the iron act as hardening agents that prevent the movement of dislocations. The carbon in typical steel alloys may contribute up to 2.14% of its weight. Varying the amount of carbon and many other alloying elements, as well as controlling their chemical and physical makeup in the final steel (either as solute elements, or as precipitated phases), impedes the movement of the dislocations that make pure iron ductile, and thus controls and enhances its qualities. These qualities include the hardness, quenching behaviour, need for annealing, tempering behaviour, yield strength, and tensile strength of the resulting steel. The increase in steel's strength compared to pure iron is possible only by reducing iron's ductility.

### 3.4.3 Round 3 Spoke Hand Wheel

A steering wheel (also called a driving wheel (UK), a hand wheel, or simply a wheel) is a type of steering control in vehicles. Steering wheels are used in most modern land vehicles, including all mass-production automobiles, buses, light and heavy trucks, as well as tractors.



Figure 3.5: Round 3 Spoke Hand Wheel

The steering wheel is the part of the steering system that is manipulated by the driver; the rest of the steering system responds to such driver inputs. This can be through direct mechanical contact as in recirculating ball or rack and pinion steering gears, without or with the assistance of hydraulic power steering, HPS, or as in some modern production cars with the assistance of computer-controlled motors, known as electric power steering.

## **History**

Near the start of the 18th century, a large number of sea vessels appeared using the ship's wheel design, but historians are unclear when that approach to steering was first used. The first automobiles were steered with a tiller, but in 1894, Alfred Vacheron took part in the Paris–Rouen race with a Panhard 4 hp model which he had fitted with a steering wheel. That is believed to be one of the earliest employments of the principle. In 1898, the Panhard Et. Levassor cars were equipped as standard with steering wheels. Charles Rolls introduced the first car in Britain fitted with a steering wheel when he imported a 6-hp Panhard from France in 1898. Arthur Constantin Krebs replaced the tiller with an inclined steering wheel for the Panhard car he designed for the 1898 Paris–Amsterdam–Paris race which ran from 7–13 July 1898.

In 1898, Thomas B. Jeffery and his son, Charles T. Jeffery, developed two advanced experimental cars featuring a front-mounted engine, as well as a steering wheel that was mounted on the left-hand side. However, the early automaker adopted a more "conventional" rear-engine and tiller-steering layout for its first mass-produced Ramblers in 1902. The following year, the Rambler Model E was largely unchanged, except that it came equipped with a tiller early in the year, but with a steering wheel by the end of 1903. By 1904, all Ramblers featured steering wheels. Within a decade, the steering wheel had entirely replaced the tiller in automobiles. At the insistence of Thomas B. Jeffery, the position of the driver was also moved to the left-hand side of the car during the 1903 Rambler production. Most other car makers began offering cars with left-hand drive in 1910. Soon after, most cars in the U.S. converted to left hand drive.

### 3.4.4 Pillow Block Bearing

A pillow block bearing (or plummer block) is a pedestal used to provide support for a rotating shaft with the help of compatible bearings and various accessories. The assembly consists of a mounting block which houses a bearing. The block is mounted to a foundation and a shaft is inserted allowing the inner part of the bearing / shaft to rotate. The inside of the bearing is typically 0.001 inches (0.025 mm) larger than the shaft to ensure a tight fit. Set screws, locking collars, or set collars are commonly used to secure the shaft. Housing material for a pillow block is typically made of cast iron or cast steel.



Figure 3.6: Pillow Block Bearing

#### **Description:**

A pillow block usually refers to a housing with an included anti-friction bearing, wherein the mounted shaft is in a parallel plane to the mounting surface, and perpendicular to the centre line of the mounting holes, as contrasted with various types of flange blocks or flange units. A pillow block may contain a bearing with one of several types of rolling elements, including ball, cylindrical roller, spherical roller, tapered roller, or metallic or synthetic bushing. The type of rolling element defines the type of pillow block. These

differ from "plumber blocks" which are bearing housings supplied without any bearings and are usually meant for higher load ratings and a separately installed bearing. Plumber block bearings are designed for more corrosive environments.

The fundamental application of both types is the same, which is to mount a bearing safely enabling its outer ring to be stationary while allowing rotation of the inner ring. The housing is bolted to a foundation through the holes in the base. Bearing housings may be either split type or solid type. Split-type housings are usually two-piece housings where the cap and base may be detached, while solid are single-piece housings. Various sealing arrangements may be provided to prevent dust and other contaminants from entering the housing. Thus the housing provides a clean environment for the environmentally sensitive bearing to rotate free from contaminants while also retaining lubrication, either oil or grease, hence increasing its performance and duty cycle. Bearing housings are usually made of grey cast iron. However, various grades of metals can be used to manufacture the same, including ductile iron, steel, stainless steel, and various types of thermoplastics and polyethylene-based plastics. The bearing element may be manufactured from 52100 chromium steel alloy (the most common), stainless steel, plastic, or bushing materials such as SAE660 cast bronze, SAE841 oil-impregnated sintered bronze, or synthetic materials.

### **Purpose**

A pillow block bearing (or plumber block) is a pedestal used to provide support for a rotating shaft with the help of compatible bearings and various accessories. The assembly consists of a mounting block which houses a bearing. A Pillow Block Bearing is a mounted anti-friction bearing that is contained within a solid cast iron, ductile iron or cast steel housing unit. Also referred to as a housed bearing unit, meaning they are self-contained, greased, sealed and ready for installation on the equipment.

### **3.4.5 Pulley Block U Shape**

A pulley is a wheel on an axle or shaft that is designed to support movement and change of direction of a taut cable or belt or transfer of power between the shaft and cable or belt. In the case of a pulley supported by a frame or shell that does not transfer power to a shaft,

but is used to guide the cable or exert a force, the supporting shell is called a block, and the pulley may be called a sheave. A pulley may have a groove or grooves between flanges around its circumference to locate the cable or belt. The drive element of a pulley system can be a rope, cable, belt, or chain.

The earliest evidence of pulleys dates back to Ancient Egypt in the Twelfth Dynasty (1991-1802 BCE) and Mesopotamia in the early 2nd millennium BCE. In Roman Egypt, Hero of Alexandria (c. 10-70 CE) identified the pulley as one of six simple machines used to lift weights. Pulleys are assembled to form a block and tackle to provide mechanical advantage to apply large forces. Pulleys are also assembled as part of belt and chain drives to transmit power from one rotating shaft to another. Plutarch's *Parallel Lives* recounts a scene where Archimedes proved the effectiveness of compound pulleys and the block-and-tackle system by using one to pull a fully laden ship towards him as if it was gliding through water.



Figure 3.7: Pulley Block U Shape



### 3.4.6 Pipe Bending Handle

Tube bending is any metal forming process used to permanently form pipes or tubing. Tube bending may be form-bound or use free form-bending procedures, and it may use heat-supported or cold forming procedures. Form bound bending procedures like “press bending” or “rotary draw bending” are used to form the work piece into the shape of a die. Straight tube stock can be formed using a bending machine to create a variety of single or multiple bends and to shape the piece into the desired form. These processes can be used to form complex shapes out of different types of ductile metal tubing. Free form-bending processes, like three-roll push bending, shape the work piece kinetically, thus the bending contour is not dependent on the tool geometry. Generally, the round stock is used in tube bending. However, square and rectangular tubes and pipes may also be bent to meet job specifications. Other factors involved in the bending process are the wall thickness, tooling and lubricants needed by the pipe and tube bender to best shape the material, and the different ways the tube may be used (tube, pipe wires).



Figure 3.8: Pipe Bending Handle Mechanism

A tube can be bent in multiple directions and angles. Common simple bends consist of forming elbows, which are bends, and U-bends, which are 180° bends. More complex geometries include multiple two-dimensional (2D) bends and three-dimensional (3D) bends. A 2D tube has openings on the same plane; a 3D has openings on different planes. A two-plane bend or compound bend is defined as a compound bend that has a bend in

the plan view and a bend in the elevation. When calculating a two-plane bend, one must know the bend angle and rotation (dihedral angle). One side effect of bending the work piece is the wall thickness changes; the wall along the inner radius of the tube becomes thicker and the outer wall becomes thinner. To reduce this the tube may be supported internally and or externally to preserve the cross-section. Depending on the bend angle, wall thickness, and bending process the inside of the wall may wrinkle.

### **Process**

Tube bending as a process starts with loading a tube into a tube or pipe bender and clamping it into place between two dies, the clamping block and the forming die. The tube is also loosely held by two other dies, the wiper die and the pressure die. The process of tube bending involves using mechanical force to push stock material pipe or tubing against a die, forcing the pipe or tube to conform to the shape of the die. Often, stock tubing is held firmly in place while the end is rotated and rolled around the die. Other forms of processing include pushing stock through rollers that bend it into a simple curve.

For some tube bending processing, a mandrel is placed inside the tube to prevent collapsing. The tube is held in tension by a wiper die to prevent any creasing during stress. A wiper die is usually made of a softer alloy such as aluminium or brass to avoid scratching or damaging the material being bent. Much of the tooling is made of hardened steel or tool steel to maintain and prolong the tool's life. However, when there is a concern of scratching or gouging the work piece, a softer material such as aluminium or bronze is utilized. For example, the clamping block, rotating form block and pressure die are often formed from hardened steel because the tubing is not moving past these parts of the machine. The pressure die and the wiping die are formed from aluminium or bronze to maintain the shape and surface of the work piece as it slides by.

# Chapter 4 Result and Discussion

## 4.1 Result

Finally, we were able to create our project successfully. After making the Mechanical body, we designed a circuit to control it and when we operated it, we called it working pretty well. It is very well controlled and can bend pipe very well. Below is a picture of our completed entire project.



Figure 4.1: Complete Project Picture (Side View)



Figure 4.2: Complete Project Picture (Top View)

#### **4.2 Discussion**

While working on our project, we did face some difficulties as it is a very complex system but the results, we came up with were quite satisfactory. We have put the whole system through several tasks to validate our work and also have taken necessary notes for future improvements. Some future recommendations that we have involve improvement in system design and wiring, and adding features for more efficient.

# Chapter 5 Conclusion

## 5.1 Application

Some of the application areas of the project have been pointed out below:

- Angle Bending
- Metal Folding
- U Hook
- Scroll Bending

## 5.2 Future Scope

By adjusting the roller guides on the bending unit, we can bend tubes and pipes. By incorporating various parts, the hydraulic bending system can be semi-automated and automated. Some of these future scopes are given below -

- In the future this machine can be operated by using Electrical, Pneumatic, and supply.
- In future we will be able to use for different curves and different shapes of pipe.
- We will arrange this machine design by using two or more pulley arrangements.
- Movable stopper is used to give more accuracy.

## 5.3 Conclusion

Nowadays, pipe bending is a common occurrence. Various automatic and semi-automatic bending systems are used in mass manufacturing. However, automated and semiautomatic pipe bending machines are expensive for limited manufacturing. They still cannot be used in areas where electricity is scarce and expensive. Manual pipe bending, on the other hand, is less costly and simple to build and run. The plans, development, and performance tests are all depicted in this paper. Manual pipe bending is less expensive and can easily be made and operated.

## References

- [1] International Journal of Machine Tools & Manufacture.
- [2] V. B .Bhandari (2012) “ Design of Machine Elements” Mc Graw Hill.
- [3] Dhavalsutar (2015) “International journal of research in mechanical engineering and technology”
- [4] Jun ZhanoGaocgaoyu Rai Ma “Journal of Material Processing Technology”
- [5] Chudasama (2014) Bending Force prediction for dynamic during the 3-roller conical bending process. Journal of the manufacturing process.
- [6] S Sumesh& AR Veerappn “Engineering Failure Analysis”
- [7] Akbar Khan &PravinGhule published “Design Development and Experimental Study of Pipe Bending Machine”
- [8] A.D.Zope. (2017). Review paper on design and development of metal bending machine. *IOSR Journal of Mechanical and Civil Engineering (IOSR-JMCE)* , 3.
- [9] Goto, H. (2008). Applications with a New 6-DOF Bending Machine in Tube Forming Processes. *Proceedings of the 7th JFPS International Symposium on Fluid Power*, 7.
- [10] Hea, Y. (2012). Advances and Trends on Tube Bending Forming Technologies. *Chinese Journal of Aeronautics*, 1-12.
- [11] Hussain, H. A. (2014). Design and Development of Bicycle Integrated Pipe Bending Machine. *Journal of Mechanical and Civil Engineering (IOSRJMCE)*, 6.
- [12] Jayakumar, A. (2019). Design and Fabrication of Roll Bending Machine. *ISSN-2349- 5162*, 3.
- [13] Khandare, P. P. (2016). Study of Portable 3-Roller Pipe Bending. *International Journal of Advanced Technology in Engineering and Science*, 4.
- [14] Pachange, R. (2019). DESIGN AND FABRICATION OF MANUAL ROLLER BENDING MACHINE. *International Research Journal of Engineering and Technology (IRJET)*, 7.