

# CONSTRUCTION AND PERFORMANCE TEST OF DIGITAL MULTIFUNCTIONAL SOLAR BOAT

**Supervised by:**

Shahinur Rahman

Lecturer.

Department of Mechanical Engineering

**Submitted by:**

Md. Ibrahim Khalil, BME-1503007542

Protimoy Majumder, BME-1901017383

Md. Shahariar Mahamud Saykat,

BME-1803016115

Md. Monirul Islam, BME-1901017504

Pijush Ghosal, BME-1901017593

Md. Shariful Bari, BME-1901017554

A thesis submitted in partial fulfilment of the requirements for the degree of  
B. Sc. Engineering in Mechanical Engineering



Department of Mechanical Engineering (ME)  
Sonargaon University (SU)  
147/I, Panthapath,  
Dhaka-1215, Bangladesh  
September 2022

## **ACKNOWLEDGEMENT**

The report titled as on “Digital Multifunctional Solar boat” has been prepared to fulfil the requirement of our practicum program. In the process of doing and preparing our practicum report, we would like to pay our gratitude to some persons for their enormous help and vast co-operation.

At first, we would like to show our gratitude to the University authority to permit us to do our practicum. Specially, we would like to thank to our honourable teacher Shahinur Rahman, Lecturer, Department of Mechanical Engineering, Sonargaon University, Dhaka, for his valuable and patient advice, sympathetic assistance, co-operation, contribution of new idea. Deep theoretical and hardware knowledge & keen interest of our supervisor in this field influenced us to carry out this project. His endless patience, scholarly guidance, continual encouragement, constant and energetic supervision, constructive criticism, valuable advice, reading many inferior draft and correcting them at all stage have made it possible to complete this project.

Finally, we would like to thanks again to the respected, Professor Md. Mostofa Hossain Head of Mechanical Engineering Department of Sonargaon University (SU), because they are designated such an environment for learning through which we got the opportunity to acquire knowledge under BSc in Mechanical program, and that will be very helpful for our prospective career. We are, indeed, grateful to all those from whom we got sincere cooperation and help for the preparation of this report.

## **AUTHORS**

## **ABSTRACT**

The aim of this paper is the “Digital Multifunctional Solar boat” transport along the coast, in the rivers, in the lakes. Our idea is to define the project guidelines for the realization of a zero impact boat. This paper illustrates the practical new technologies (naval architecture small craft design, mechanical and electrical design), rational design and engineering approach, safety and reliability methods used in solar boats. In our project, the boat is powered by lithium-ion batteries that can be charged at any time by the photovoltaic generator placed on a flat top structure. The project is designed for brief trip around coast, where the public transport becomes very polluting during summer. Starting from the consideration that this boat is used during sunny weather, it is possible to know the boat’s energy demand and proceed with the design of a suitable electric boat and of the energy storage/management system. It is also proposed an innovative management of charge/discharge of the batteries. With this management, we have optimized the use and prolonged the time of life of the batteries during the navigation and the control of the real autonomy of it.

## List of Contents

NAME	
Sonargaon University (SU)	i
ACKNOWLEDGEMENT	ii
ABSTRACT	iii
List of Figure	iv
List of Table	v
<b>Chapter-1</b>	<b>1-4</b>
Introduction	1
1.1 Introduction	1
1.2 OBJECTIVE	2
1.3 Methodology	3
1.4 LITERATURE REVIEW	4
1.5 LEARNING GOAL(S):	4
<b>Chapter-2</b>	<b>5-6</b>
Theory of this project	6
2.1 introduction	6
2.2 Theory.	7
2.3 Solar Panel	8-11
2.3 NE 555 Timer	11-15
2.5 LCD Display	16-18
2.6 Step Up Transformer	19
2.6 12V Rechargeable Battery	20
2.7 GSM SIM800L Module	20
<b>Chapter-3</b>	<b>21-25</b>
3.1 CIRCUIT DIAGRAM OF THIS PROJECT	21
3.2 BLOCK DIAGRAM OF THIS PROJECT	22
3.2 BLOCK DIAGRAM OF THIS PROJECT	22

3.3 COMPONENT LIST	23
3.4 Working principle	24-25
<b>Chapter-4</b>	26-27
4.1 Introduction	26
4.2 Result	26
4.3 Advantages	26
4.4 Disadvantages	26
4.5 Applications	26
4.6 Discussion	26
4.7 Management Control	27
<b>Chapter-5</b>	28-29
5.1 Conclusion	28
5.2 Future Work	28-29

## REFERENCES

## List of Figure

Figure 2. 1 Structure Solar panel	8
Figure 2. 3 NE555 timer IC	11
Figure 2. 4 Arduino nano	12
Figure 2. 5 Arduino Architecture	13
Figure 2. 6 Arduino Pin Diagram	13
Figure 2. 7 Arduino Programming	14
Figure 2. 8 LCD DISPLAY	16
Figure 2. 9 LCD Constructer	17
Figure 2. 10 Transformer Constructure	18
Figure 2. 11 Rechargeable Battery	19
Figure 3. 1 Circuit Diagram	21
Figure 3. 2 Block Diagram	22

## Chapter-1

### 1.1 Introduction

Many protected areas in the world are facing the growth of tourism pressure; the same problem is present in the areas of naturalistic interest. Tourism is seen as a viable financial option for protected areas with the tourism concessions, through private sector partnerships, that permitted to gaining momentum and that allows the over-arching goal of preservation and conservation to remain with the state. However, without appropriate planning or best practices in place, tourism concessions can lead to such problems as waste, habitat destruction and the displacement of local people and wildlife. In other words, tourism brings economic benefits to countries, but there are usually substantial socio-economic and environmental costs associated with it. The inherent conflict between protecting ecosystems and cultural heritage on one hand and providing public use programs and related infrastructure and visitor services in protected natural and cultural areas on the other hand is as old as the modern conservation movement [1].

Similar problems exist with the tourism on coastal environments [2].

Tourists' transport along the coast, in the rivers, in the lakes, can be performed on route well-defined and carried out with boats that sail at low speed. Therefore, starting from the design of a hull that minimizes the drag, In this paper it will be illustrate a

"system" for tourist navigation with an "exclusively" electric boat propelled [3-5].

The ship is powered by direct solar energy. Our boat uses solar cells that transform the solar energy into electrical energy, which is stored temporarily in lithium-ion batteries, and used to drive the boat through electric motors (permanent magnet synchronous motors) and drive systems [6,7];

Electric propulsion offers effective manoeuvrability, precise and smooth speed control, reduced engine room, low noise and low pollution rates. Solar-electric boats are recommended solution for tourist navigation in areas where combustion engines are prohibited (lake, protected areas, etc.). Actually, many solar-electric boats are available [810],

## **1.2 OBJECTIVE:**

The main objective for this project is to design and develop a solar boat that is powered by an electric motor which gets its supply from photovoltaic (PV) panels and partially uses solar energy. Besides that, the objective is to develop a solar powered electric boat that can minimize and economical the electricity uses for its electric motor and maximizes the usefulness of solar energy in our life economically and efficiently, and then extends the system for commercial market. Another objective is to study the relationship between electric propulsion and solar energy and wiring connection between solar panel, converter, rechargeable battery and electric motor in developing a solar boat. The last objective is to study the characteristics of solar energy to produce alternative renewable energy and make analysis about the appropriate method to use the solar energy as an alternative source of energy.

To design a solar boat that using solar power as an alternative

To produce a solar powered boat that is free emissions including CO<sub>2</sub> that caused Green house Effect.

Solar energy is completely free. Sure, there is an initial capital cost but once you have made the investment the energy harvested from the sun costs you nothing.



### **1.3 Methodology:**

First the requirements of the project was carefully analysed to design the solar boat.

The methodology of this project design can be divided into two sections; hardware and software implementations.

Information's were collected from references books and websites to find out the possible improvement.

Required components have been purchased from local market.

Start building hardware and software.

### **1.4 LITERATURE REVIEW:**

This chapter will be stressed on the literature review of related system. The main purpose of this chapter is to analyse, identify and make conclusion based on the research. A literature review means a collecting related data, analysed business process, identify underlying patterns and create the conclusion. Another description of the literature review is a systematic, explicit and reproducible method to identifying, evaluating and synthesizing the existing body of completed and recorded work produced by researcher, scholars and practitioners. In order to develop a successful project, the current systems are identified. The system of conventional electric boat, solar system and its connection have been analysed. Studies of these systems are significant to develop a valid, reliable and efficient upgrade project. The Literature Review part acts as a mean to discover which methodology should be chosen in developing this system.

Research in the application of renewable energy has intensified in recent years. The possibility of petroleum extinction in the future is forcing researchers to enhance the utilization of renewable energy resources as substitute for fossil fuel-based technologies in all fields. Ships as one of the most important transportation in the world also require diesel oil as fuel for main propulsion systems and for diesel generators which supply electrical needs. Solar energy has been considered as the most suitable renewable energy resources to substitute the role of fuel in the ships. In this paper, the latest research on the utilization of solar energy in the ship are presented and analysed to provide information for the researchers who developed the technology of solar-powered boat

### **1.5 LEARNING GOAL(S):**

Students will follow step-by-step instructions to build their solar boats. They will troubleshoot as necessary by making sure electricity flows into the motor to make the vehicles move by propeller or gears. Students will determine different data points that are useful in the determining the most effective design for a solar powered boat. Students will undergo the process of redesign, noting why they made changes to particular variables on their boat and noting how these changes played out.

#### **NEXT GENERATION SCIENCE STANDARDS:**

4-PS3-2. Make observations to provide evidence that energy can be transferred from place to place by sound, light, heat, and electric currents.

4-PS3-4. Apply scientific ideas to design, test, and refine a device that converts energy from one form to another.

3-5-ETS1-1. Define a simple design problem reflecting a need or a want that includes specified criteria for success and constraints on materials, time, or cost.

3-5-ETS1-2. Generate and compare multiple possible solutions to a problem based on how well each is likely to meet the criteria and constraints of the problem.

PS2-1 Apply Newton's Third Law to design a solution to a problem involving the motion of two colliding objects. • PS2- 2 Plan an investigation to provide evidence that the change in an object's motion depends on the sum of the forces on the object and the mass of the object.

#### **STUDENT BACKGROUND:**

Students should understand the fundamentals of energy, energy transfer, circuits and that light hitting a solar panel generates electricity.

## Chapter-2

### Theory of this project

#### 2.1 Introduction:

Worldwide, there are more than 20 million pleasure boats and nearly 10 million of them are in the USA. Approximately 236,000 metric tons of hydrocarbons from boats finds its way into the water every year, equivalent to more than seven times the amount spilled by the Exxon Valdez in Alaska in 1989 [1].

Many boat motors are of the 2-stroke design that burn a mix of oil and gas. These types of motors may be eight times more pollutant than four-stroke motors, since up to 25% of the fuel might be emitted half-burned through the exhaust into the water.

Many people are aware of agricultural pollution in many Midwestern states. Iowa's lakes and rivers are among the most troubled. However, oil and gas leaks, particularly from old boats, illustrate a need for developing eco-friendly boat technologies such as solar powered boats.

For the past three years, the University of Northern Iowa (UNI) has participated in the Solar Splash international solar boat competition in Buffalo, New York. Each year has been a learning experience for the teams that were involved. Although touching briefly on the first two years, this paper will explore the efforts of the 2004 UNI solar boat team and give a glimpse of what the future holds for the 2005 team.

The team approached the project as a problem-solving exercise. As in previous years, the problem could be defined as: "Finding effective and efficient alternatives to internal combustion powered aquatic recreational transportation". There are several reasons beyond the educational experience for undertaking this project:

- Finding an alternative method of getting from point A to point B without emitting roughly 8.6 kg of CO<sub>2</sub> for every gallon of fuel consumed.
- To showcase solar-electric technology in a novel manner.
- Development of a method of recreational transportation that is pollution-free to the streams and lakes that is applicable to our state, country and world.
- To do all of this without taking the fun out of it all.

Because the details of the problem faced by each team differed, the methods pursued would differ each year. The first-year team was primarily concerned with making an entry. Subsequent teams built upon the knowledge, experience and challenges encountered by the previous team(s).

The project's main sponsor is Iowa Energy Centre (IEC), a non-profit state organization which invests its resources to create a stable energy future for the state of Iowa. Local industries such as Deere and Company, WBM Marine of Waterloo, Square-D Inc, and Rockwell-Collins Inc. also support the project.

This paper describes detailed design and construction of a solar-electric powered boat. This includes sub-systems such as; a fiberglass hull, an electromechanical drive system, pulse width modulated (PWM) based speed control, and custom-made photovoltaic cell modules using commercially available cells. The project has been an excellent asset to the capstone senior design class offered for the ELET and Manufacturing Technology majors at UNI. Students involved in the project have gained knowledge and skills in electrical and mechanical areas. They also improved their social skills since they had to visit many companies and present the project.

## 2.2 Theory:

### 2.2.1 Photovoltaic Generating System

In our boat the area available for installing a photovoltaic array is about 55 m<sup>2</sup>. On this area, it is possible to install 42 Sanyo's HIT Power 225 A solar module; every single panel has a dimension of 1.580 mm × 798 mm × 46 mm, Maximum Power Voltage (V<sub>mp</sub>) 43.4 V, Maximum Power Current (I<sub>mp</sub>) 5.21 A, which leads to a Maximum Output Power (W<sub>Pmax</sub>) 225 W in Standard Test Conditions. We configure the connection of the panels in this way: 6 strings of 7 panels in series, providing an output maximum power voltage of 304 V, and maximum power current of 31.26 A. The yearly average electrical energy from photovoltaic array is given by the following equation

$$E_{DC} = P_{PV} \cdot W \cdot K_1 \cdot K_2 \cdot K_3 \cdot K_4 \quad (1)$$

$E_{DC}$  is the photovoltaic energy [kWh/year].

$P_{PV}$  is the photovoltaic array energy output at standard radiation; in our case:

$$P_{PV} = 0.225 \text{ kW} \cdot 42 \text{ panels} = 9.450 \text{ kW}$$

$W$  is the yearly average flux of solar radiation; in this work we consider a global horizontal irradiation of 1500 kWh/m<sup>2</sup>/year.

$K_1$  is a coefficient for compensating temperature effect. Operating temperature increases when module where placed in the sun. When operating temperature increases, power output decreases (due to the properties of the conversion material—this is true for all solar modules). For our photovoltaic panel  $K_1 = 0.9$  is a good approximation.

$K_2$  is the coefficient that take account of the stain and wear, factor that worsen with the passage of time. A typical value of  $K_2$  can be estimated with 0.96.

$K_3$  is the coefficient that take account of DC circuit losses. Typical solar electric systems require more than one module to be connected to another one. The wires used to connect the modules create a slight resistance in the electrical flow, that decrease the total power output of the system, similar to low pressure water flowing through a long water hose. In addition, slight differences in power output from module-to-module reduce the maximum power output available from each module. A typical value of the losses is 0.95.

$K_4$  is the coefficient that take account of the losses of the DC-DC converter, in order to be converted for the DC power from the solar modules to the usable one (battery charge, motors, etc.). The conversion DC-DC decreases approximately of 0.95. With these considerations, the energy from our 42 Sanyo's HIT Power 225 A solar module will be about 11 MWh; the photovoltaic array is able to furnish all the energy necessary to the navigation. In other words, the boat is driven by two electric motors powered "exclusively" with rechargeable batteries. The energy stored in the batteries derives through renewable energy sources. The photovoltaic array is sized to provide, on average in a year, all the energy required by the boat. The boat is grid connected to a harbor; it can put in grid the energy produced in excess and to furnish, when necessary, the energy for the recharge of the batteries.

### **2.2.2 Power Management System (PMS)**

The PMS is used for the right managing of the energy aboard. Our idea is to provide the master with the real autonomy of navigation and the real power from the battery. In our system, a storage device (battery bank) is used for balancing the mismatch between the available energy by the photovoltaic array and power required by motors and ship instruments. Both the powers that flow in and out of the storage device have to be designed accurately and controlled for a global energy management strategy. In particular, since the lithium-ion batteries decrease the storage capacity with aging, is not possible for the captain to know the instant energy available for the navigation, by measuring the output voltage of the battery.

For a safety and reliable navigation, it is necessary to know the real autonomy of navigation, which means to know the real energy storage within the battery banks. It is often important in fact to provide accurate information regarding the remaining capacity of the battery. Some batteries provide a “fuel gauge” that gives an indication of the charge level of the battery. output voltage; otherwise, if the output power decreases, that means it works on the right of the maximum power point, the disturbance direction will be away from the maximum power point, thus it should change the disturbance direction to decrease the output voltage of photovoltaic array. When the cycle is complete the system is adjust, so finally, the maximum power point will be found

### **2.2.3 Charge and Discharge Controllers**

Charge controller, through the information received by the management control, sends the energy that comes from the photovoltaic array, to the fully discharged battery bank. During the charge process, charge controller measures the flow of incoming energy in the battery bank. When the battery bank is completely charged, the energy flow is sent to another fully discharged battery bank. In the eventuality that there are no fully discharged battery banks the energy flow is sent to the loads through the discharge controller; in alternative, the energy flow is sent to the grid if it is connected. The discharge control carries to discharge fully a single battery bank at a time. During the discharge process the discharge control measures the energy flow and management control compares this with one memorized during the preceding charge. Through this comparison is possible to establish the aging of the battery and to determine the real storable energy.

## 2.3 Solar Panel

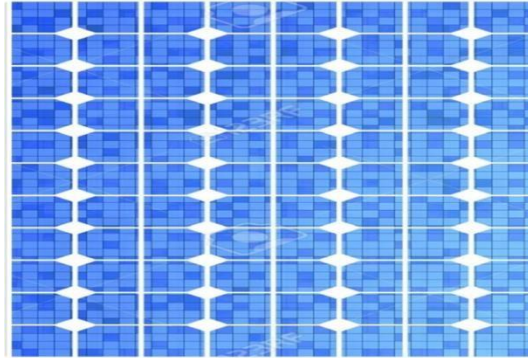

Figure 2. 1 Structure Solar panel

- Mono Crystalline solar panel
- Cost effective
- More efficient and reliable
- Made of bulk type silicon

### 2.3.1 How Solar Cells Work — Components & Operation Of Solar Cells

Since a solar cell is the only generator in a solar PV system, it is one of the most important parts in a solar PV system. In the following paragraphs, a simple introduction of a solar cell and how it operates is discussed, with reference links for better understanding.

A solar cell: A solar cell is a solid-state electrical device (p-n junction) that converts the energy of light directly into electricity (DC) using the photovoltaic effect. The process of conversion first requires a material which absorbs the solar energy (photon), and then raises an electron to a higher energy state, and then the flow of this high-energy electron to an external circuit. Silicon is one such material that uses such process. A solar cell structure is shown in figure 1 and a solar panel configuration in figure 2.

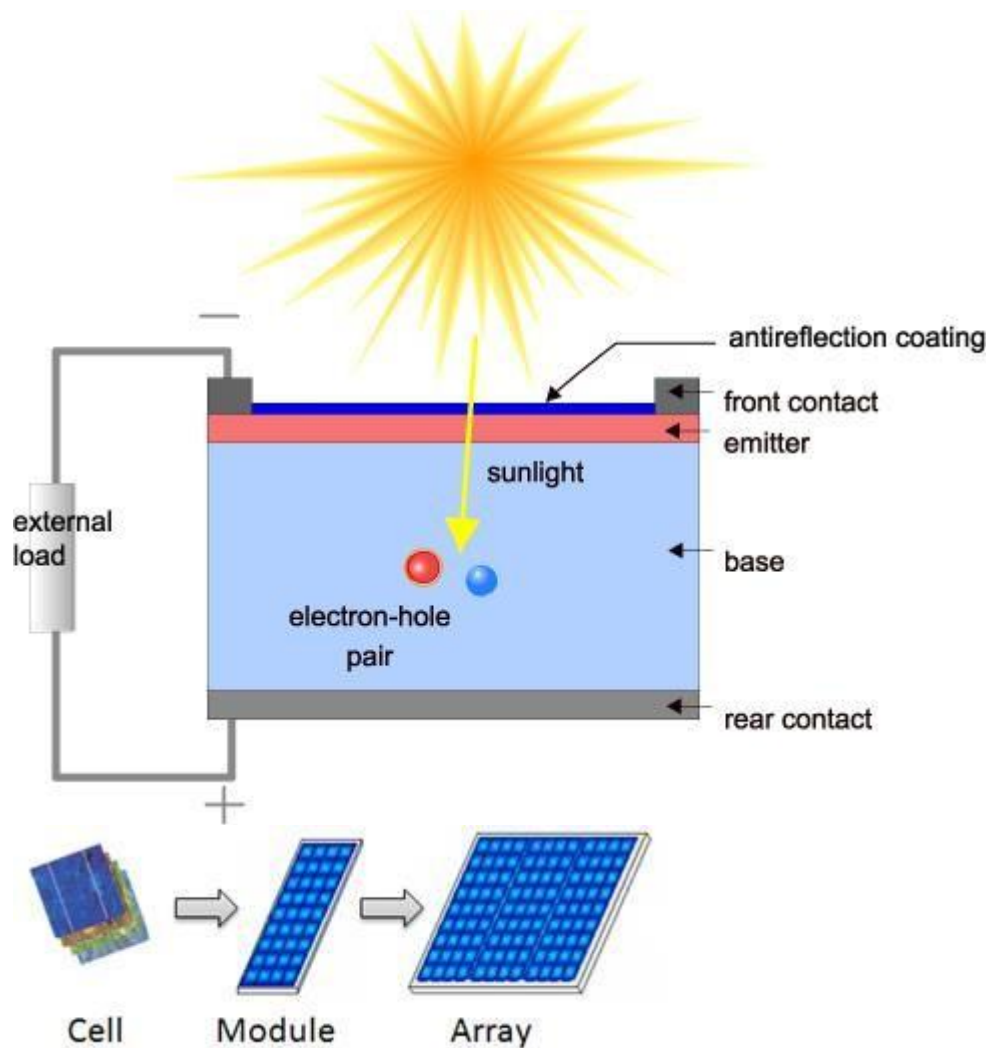

Figure 2. 2 Structure of PV cell

PVcells: PV cells are most commonly made of silicon, and come in two common varieties, crystalline and thin-film cells, as detailed in table 1.

	Bulk type / Wafer-based (Crystalline)			
	Mono-crystalline Si	Poly-crystalline Si	Poly-crystalline band	
Pros	• High efficiency	• High efficiency with respect to price	-	
Cons	• Increased manufacturing cost caused by the supply shortage silicon		-	
	Thin-film type			
	Amorphous Si	CIGS	CdTe	Polymer organic
Pros		• Low price		• Low manufacturing
Cons	• Low price	• Able to automate all manufacturing process		• Can be more efficient (still in research)
	• Low efficiency	• Low efficiency		

Table 2. 1 Type of solar cell

### **2.3.2 p-n junction:**

It is formed by joining p-type (high concentration of hole or deficiency of electron) and n-type (high concentration of electron) semiconductor material. Due to this joining, excess electrons from n-type try to diffuse with the holes of p-type whereas excess hole from p-type try to diffuse with the electrons of n-type. Movement of electrons to the p-type side exposes positive ion cores in the n-type side, while movement of holes to the n-type side exposes negative ion cores in the p-type side, resulting in an electric field at the junction and forming the depletion region

### **2.3.3 A light-generated current:**

Generation of current in a solar cell, known as the “light-generated current,” involves two important processes.

Absorption of incident photons to create electron-hole pairs. Electron-hole pairs will generate in the solar cell provided that the incident photon has an energy greater than that of the band gap. However, electrons (in the p-type material), and holes (in the n-type material) are metastable and will only exist, on average, for a length of time equal to the minority carrier lifetime before they recombine. If the carrier recombines, then the light-generated electron-hole pair is lost and no current or power can be generated.

Collection of these carriers by the p-n junction prevents this recombination by using a pn junction to spatially separate the electron and the hole. The carriers are separated by the action of the electric field existing at the p-n junction. If the light-generated minority carrier reaches the p-n junction, it is swept across the junction by the electric field at the junction, where it is now a majority carrier. If the emitter and base of the solar cell are connected together (i.e., if the solar cell is short-circuited), then the light-generated carriers flow through the external circuit.

### **2.3.4 Photovoltaic effect:**

The collection of light-generated carriers does not by itself give rise to power generation. In order to generate power, a voltage must be generated as well as a current. Voltage is generated in a solar cell by a process known as the “photovoltaic effect.” The collection of light-generated carriers by the p-n junction causes a movement of electrons to the n-type side and holes to the p-type side of the junction. Under short circuit conditions, the carriers exit the device as light-generated current. With this basic idea of the operation of a solar cell, a thorough explanation of modelling of a solar cell by using a diode with the diode ideality factor and the operation temperature as well as the parasitic resistance (due to manufacturing defects) will be discussed later.



## 2.3 NE 555 Timer

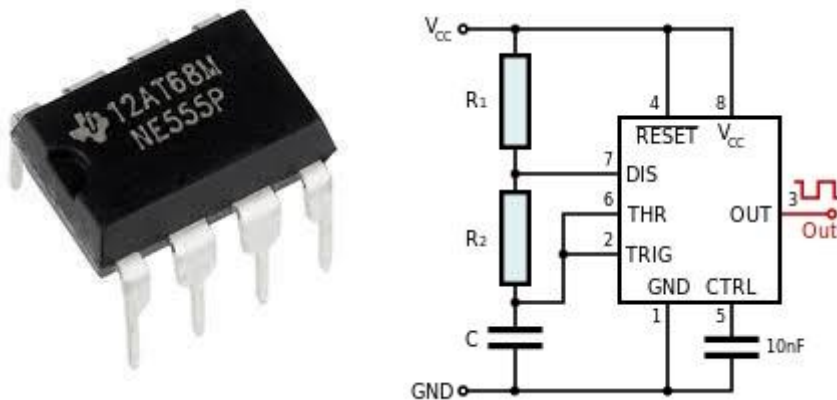

Figure 2. 3 NE555 timer IC

The 555 timer IC is an integrated circuit (chip) used in a variety of timer, pulse generation, and oscillator applications. The 555 can be used to provide time delays, as an oscillator, and as a flip-flop element. Derivatives provide two (556) or four (558) timing circuits in one package. Introduced in 1972[3] by Signetics,[4] the 555 is still in widespread use due to its low price, ease of use, and stability. It is now made by many companies in the original bipolar and in low-power CMOS technologies.

As of 2003, it was estimated that 1 billion units were manufactured every year. The 555 is the most popular integrated circuit ever manufactured.

Die of the first 555 chip (1971) The IC was designed in 1971 by Hans R. Camenzind under contract to Signetics (later acquired by Philips Semiconductors, and now NXP). In 1962, Camenzind joined PR Mallory's Laboratory for Physical Science in Burlington, Massachusetts.

He designed a pulse-width modulation (PWM) amplifier for audio applications,[8] but it was not successful in the market because there was no power transistor included. He became interested in tuners such as a gyrator and a phase-locked loop (PLL).

He was hired by Signetics to develop a PLL IC in 1968. He designed an oscillator for PLLs such that the frequency did not depend on the power supply voltage or temperature. However, Signetics laid off half of its employees, and the development was frozen due to a recession.

Camenzind proposed the development of a universal circuit based on the oscillator for PLLs, and asked that he would develop it alone, borrowing their equipment instead of having his pay cut in half.

Other engineers argued the product could be built from existing parts, but the marketing manager bought the idea. Among 5xx numbers that were assigned for analogue ICs, the special number "555" was chosen.

Camenzind also taught circuit design at Northeastern University in the morning, and went to the same university at night to get a master's degree in Business Administration.[10] The first design was reviewed in the summer of 1971. There was no problem, so it proceeded to layout design.

A few days later, he got the idea of using a direct resistance instead of a constant current source, and found that it worked. The change decreased the required 9 pins to 8, so the IC could be fit in an 8-pin package instead of a 14-pin package.

This design passed the second design review, and the prototype was completed in October 1971. Its 9-pin copy had been already released by another company founded by an engineer who attended the first review and retired from Signetics, but they withdrew it soon after the 555 was released. The 555 timer was manufactured by 12 companies in 1972 and it became the best selling product.[9]

## 2.4 Function of Arduino NANO

### Defining Arduino

An Arduino is actually a microcontroller based kit which can be either used directly by purchasing from the vendor or can be made at home using the components, owing to its open source hardware feature. It is basically used in communications and in controlling or operating many devices. It was founded by Massimo Banzi and David Cuartielles in 2005.



Figure 2. 4 Arduino nano

Arduino's processor basically uses the Harvard architecture where the program code and program data have separate memory. It consists of two memories- Program memory and the data memory. The code is stored in the flash program memory, whereas the data is stored in the data memory. The Atmega328 has 32 KB of flash memory for storing code (of which 0.5 KB is used for the bootloader), 2 KB of SRAM and 1 KB of EEPROM and operates with a clock speed of 16MHz.

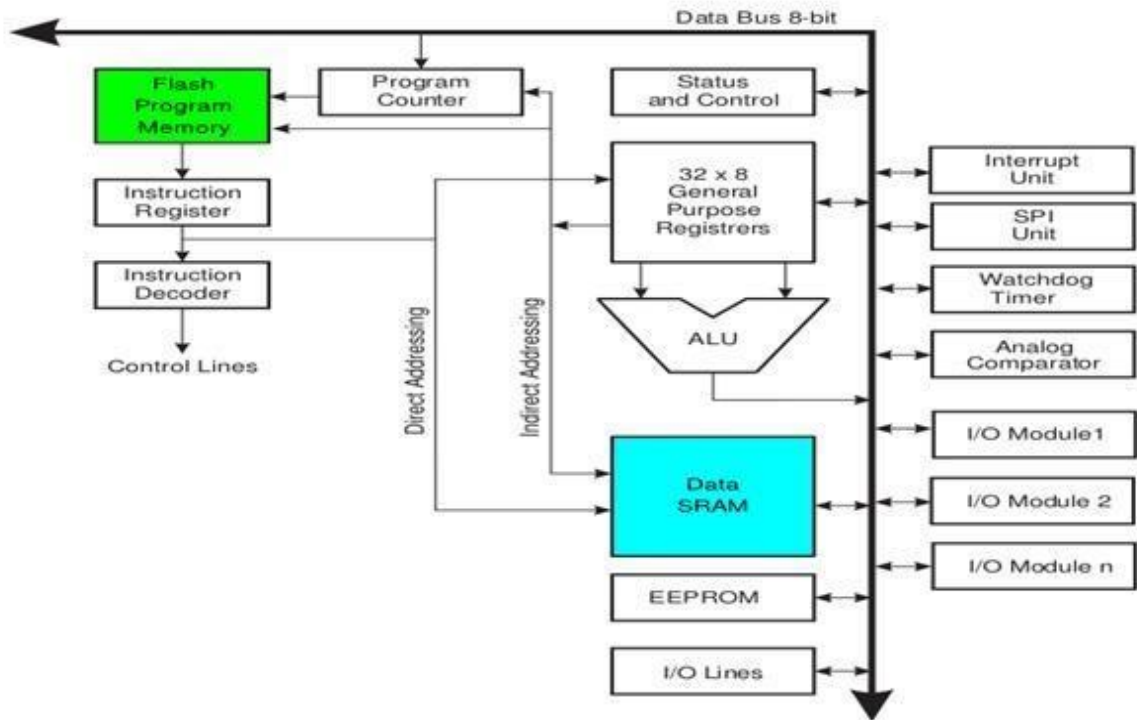

Figure 2. 5 Arduino Architecture

A typical example of Arduino board is Arduino Uno. It consists of ATmega328- a 28 pin microcontroller.

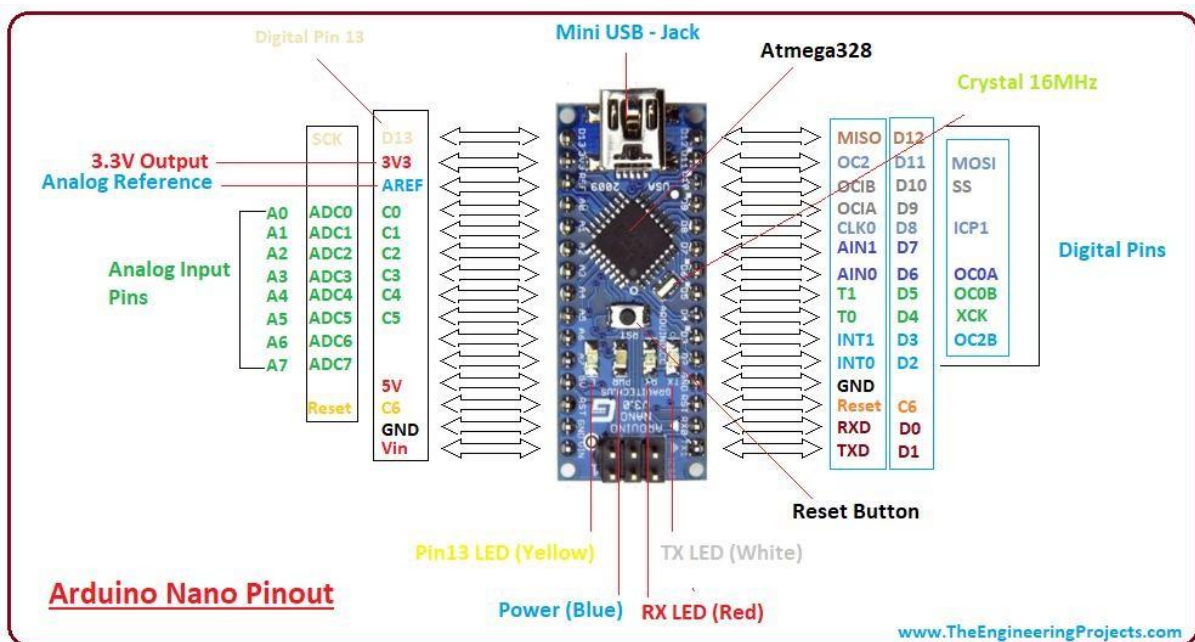

Figure 2. 6 Arduino Pin Diagram

**Power Jack:** Arduino can be power either from the pc through a USB or through external source like adaptor or a battery. It can operate on a external supply of 7 to 12V. Power can be applied externally through the pin Vin or by giving voltage reference through the IOREf pin.

**Digital Inputs:** It consists of 14 digital inputs/output pins, each of which provide or take up 40mA current. Some of them have special functions like pins 0 and 1, which act as Rx and Tx

respectively, for serial communication, pins 2 and 3-which are external interrupts, pins 3,5,6,9,11 which provides pwm output and pin 13 where LED is connected.

**Analog inputs:** It has 6 analog input/output pins, each providing a resolution of 10 bits.

**ARef:** It provides reference to the analog inputs

**Reset:** It resets the microcontroller when low.

### 2.4.1 How to program an Arduino?

The most important advantage with Arduino is the programs can be directly loaded to the device without requiring any hardware programmer to burn the program.

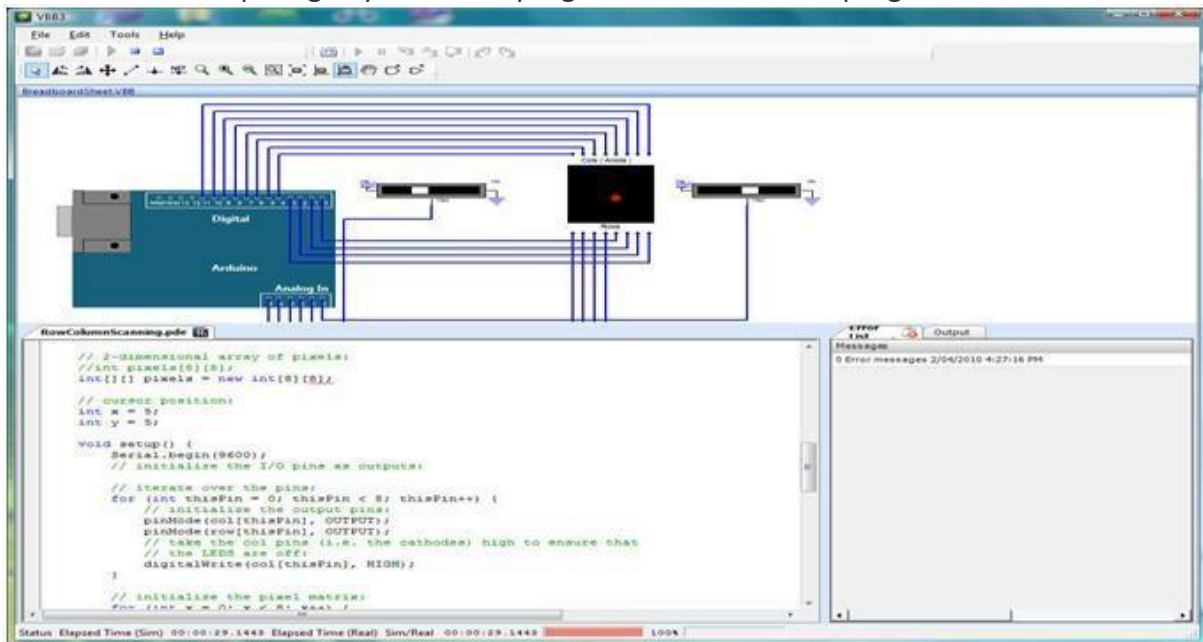

Figure 2. 7 Arduino Programming

This is done because of the presence of the 0.5KB of Bootloader which allows the program to be burned into the circuit. All we have to do is to download the Arduino software and writing the code.

The Arduino tool window consists of the toolbar with the buttons like verify, upload, new, open, save, serial monitor. It also consists of a text editor to write the code, a message area which displays the feedback like showing the errors, the text console which displays the output and a series of menus like the File, Edit, Tools

### 5 Steps to program an Arduino

Programs written in Arduino are known as sketches. A basic sketch consists of 3 parts

Declaration of Variables

Initialization: It is written in the setup () function.

Control code: It is written in the loop () function.

The sketch is saved with no extension. Any operations like verifying, opening a sketch, saving a sketch can be done using the buttons on the toolbar or using the tool menu.

The sketch should be stored in the sketchbook directory.

Chose the proper board from the tool's menu and the serial port numbers.

Click on the upload button or chose upload from the tool's menu. Thus, the code is uploaded by the bootloader onto the microcontroller.

Few of basic Arduino functions are:

**digital Read**(pin): Reads the digital value at the given pin.

**digital Write**(pin, value): Writes the digital value to the given pin.

**pin Mode**(pin, mode): Sets the pin to input or output mode.

**analogRead**(pin): Reads and returns the value.

**AnalogWrite**(pin, value): Writes the value to that pin.

**Serialbegin**(baud rate): Sets the beginning of serial communication by setting the bit rate.

How to Design your own Arduino?

We can also design our own Arduino by following the schematic given by the Arduino vendor and also available at the websites. All we need are the following components- A breadboard, a led, a power jack, a IC socket, a microcontroller, few resistors, 2 regulators, 2 capacitors. •The IC socket and the power jack are mounted on the board.

Add the 5v and 3.3v regulator circuits using the combinations of regulators and capacitors.

Add proper power connections to the microcontroller pins.

Connect the reset pin of the IC socket to a 10K resistor. • Connect the crystal oscillators to pins 9 and 10

Connect the led to the appropriate pin.

Mount the female headers onto the board and connect them to the respective pins on the chip.

Mount the row of 6 male headers, which can be used as an alternative to upload programs.

Upload the program on the Microcontroller of the readymade Arduino and then pry it off and place back on the user kit.

7 Reasons why Arduino is being preferred these days

It is inexpensive

It comes with an open source hardware feature which enables users to develop their own kit using already available one as a reference source.

The Arduino software is compatible with all types of operating systems like Windows, Linux, and Macintosh etc.

It also comes with open source software feature which enables experienced software developers to use the Arduino code to merge with the existing programming language libraries and can be extended and modified.

It is easy to use for beginners.

We can develop an Arduino based project which can be completely stand alone or projects which involve direct communication with the software loaded in the computer.

It comes with an easy provision of connecting with the CPU of the computer using serial communication over USB as it contains built in power and reset circuitry.

## 2.5 LCD Display

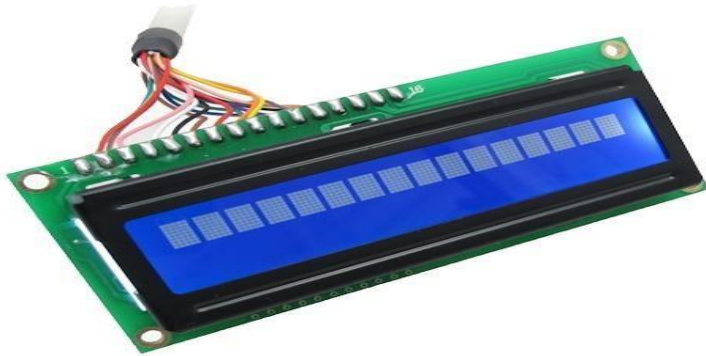

Figure 2. 8 LCD DISPLAY

LCD (Liquid Crystal Display) screen is an electronic display module  
These modules are preferred over seven-segment and other multi-segment LEDs  
LCDs are economical

### 2.5.1 Construction and Working Principle of LCD Display

What is a LCD (Liquid Crystal Display)?

A liquid crystal display or LCD draws its definition from its name itself. It is a combination of two states of matter, the solid and the liquid. LCD uses a liquid crystal to produce a visible image. Liquid crystal displays are super-thin technology display screens that are generally used in laptop computer screens, TVs, cell phones and portable video games. LCD technologies allow displays to be much thinner when compared to cathode ray tube (CRT) technology.

Liquid crystal display is composed of several layers which include two polarized panel filters and electrodes. LCD technology is used for displaying the image in notebook or some other electronic devices like mini computers. Light is projected from a lens on a layer of liquid crystal. This combination of colored light with the grayscale image of the crystal (formed as electric current flows through the crystal) forms the colored image. This image is then displayed on the screen.

An LCD is either made up of an active matrix display grid or a passive display grid.

Most of the smartphones with LCD display technology use active matrix display, but some of the older displays still make use of the passive display grid designs. Most of the electronic devices mainly depend on liquid crystal display technology for their display. The liquid has a unique advantage of having low power consumption than the LED or cathode ray tube.

Liquid crystal display screen works on the principle of blocking light rather than emitting light. LCDs require backlight as they do not emit light by themselves. We always use devices which are made up of LCDs displays which are replacing the use of cathode ray tube. Cathode ray tube draws more power compared to LCDs and are also heavier and bigger.

### 2.5.2 How LCDs are Constructed?

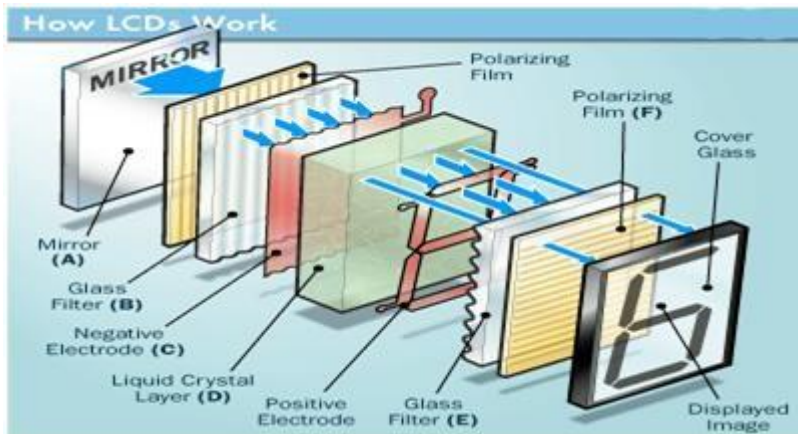

Figure 2. 9 LCD Constructer

Simple facts that should be considered while making an LCD:

The basic structure of LCD should be controlled by changing the applied current.

We must use a polarized light.

Liquid crystal should be able to control both of the operation to transmit or can also be able to change the polarized light.

As mentioned above that we need to take two polarized glass pieces filter in the making of the liquid crystal. The glass which does not have a polarized film on the surface of it must be rubbed with a special polymer which will create microscopic grooves on the surface of the polarized glass filter. The grooves must be in the same direction of the polarized film. Now we have to add a coating of pneumatic liquid phase crystal on one of the polarized filter of the polarized glass. The microscopic channel cause the first layer molecule to align with filter orientation. When the right angle appears at the first layer piece, we should add a second piece of glass with the polarized film. The first filter will be naturally polarized as the light strikes it at the starting stage.

Thus the light travels through each layer and guided on the next with the help of molecule. The molecule tends to change its plane of vibration of the light in order to match their angle. When the light reaches to the far end of the liquid crystal substance, it vibrates at the same angle as that of the final layer of the molecule vibrates. The light is allowed to enter into the device only if the second layer of the polarized glass matches with the final layer of the molecule.

### 2.5.3 How LCDs Work?

The principle behind the LCD's is that when an electrical current is applied to the liquid crystal molecule, the molecule tends to untwist. This causes the angle of light which is passing through the molecule of the polarized glass and also cause a change in the angle of the top polarizing filter. As a result a little light is allowed to pass the polarized glass through a particular area of the LCD. Thus that particular area will become dark compared to other.

The LCD works on the principle of blocking light. While constructing the LCD's, a reflected mirror is arranged at the back. An electrode plane is made of indium-tin oxide which is kept on top and a polarized glass with a polarizing film is also added on the bottom of the device. The complete region of the LCD has to be enclosed by a common electrode and above it should be the liquid crystal matter.

Next comes to the second piece of glass with an electrode in the form of the rectangle on the bottom and, on top, another polarizing film. It must be considered that both the pieces are kept at right angles. When there is no current, the light passes through the front of the LCD it will be reflected by the mirror and bounced back. As the electrode is connected to a battery

the current from it will cause the liquid crystals between the common-plane electrode and the electrode shaped like a rectangle to untwist. Thus, the light is blocked from passing through. That particular rectangular area appears blank.

#### 2.5.4 Advantages of an LCD's:

LCD's consumes less amount of power compared to CRT and LED

LCDs are consisting of some microwatts for display in comparison to some mill watts for LED's

LCDs are of low cost

Provides excellent contrast

LCD's are thinner and lighter when compared to cathode ray tube and LED

#### 2.5.5 Disadvantages of an LCD's:

Require additional light sources

Range of temperature is limited for operation

Low reliability

Speed is very low

LCD's need an AC drive

#### 2.5.6 Applications of Liquid Crystal Display

Liquid crystal technology has major applications in the field of science and engineering as well on electronic devices.

Liquid crystal thermometer

Optical imaging

The liquid crystal display technique is also applicable in visualization of the radio frequency waves in the waveguide

Used in the medical applications

## 2.6 Step Up Transformer

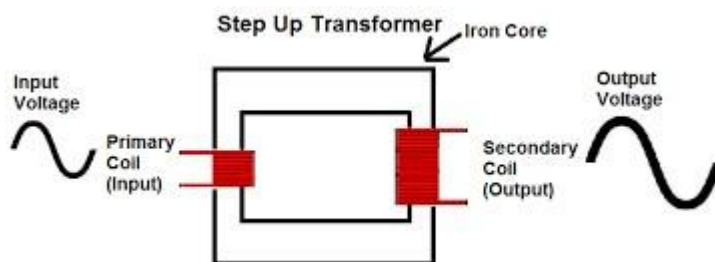

Figure 2.10 Transformer Constructure

A step-up transformer acts as a voltage-increasing device. The amount by which it increases the input voltage depends on the ratio of the number of turns in the primary coil to the number of turns in the secondary coil.

If, for example, the secondary coil has double the amount of turns as the primary coil, the ratio will be 1:2 and the output voltage will be double the input voltage.

Though step-up transformers increase the voltage of the output voltage, it comes at a price. Transformers are simply conversion devices. They do not create voltage or power. So if a step-up transformer increases voltage, it decreases current. If it doubles the voltage output, the current output gets cut in half. So that the output signal now has half the current capability as the input signal. Step-up transformers never create power; they only convert it into different forms



## 2.6 12V Rechargeable Battery



Figure 2. 11 Rechargeable Battery

The battery is an essential component of electric car. It serves for ensuring start of the engine. In addition, the battery is a supplier of electric energy in an onboard network of the car. Typically, the battery consists of a container which is divided by partitions into cells.

In these cells they are called banks there are several interconnected special units. 12-volt car battery has 6 of these cells. Each of these units contains a set of positive and negative electrodes.

Between different-pole electrodes consisting of lead grids smeared with an active substance are installed separators made of non-conducting material. When casting the battery in working condition inside the cans poured an electrolyte (a mixture of sulfuric acid and water) then it is loaded by means of the special charger.

In the process of increasing the charge density of the electrolyte inside the battery there are certain chemical reactions as a result of which there is an energy accumulation. The operating principle of the battery.

The principle of operation of lead-acid batteries is based on electrochemical reactions of lead and lead dioxide in sulfuric acid medium. The energy is formed as a result from lead oxidation by sulfuric acid to sulphate. The electrode from oxide of lead could be graphite with hydrogen allocation. Lead oxide is necessary only to prevent hydrogen allocation on electrode. Hydrogen reacts with oxygen of oxide and forms water, restoring oxide to the metal and perhaps provides an additional output of energy from the oxidation of hydrogen.

At the time of discharge there is a restoration of lead dioxide on the cathode and oxidation at the anode lead. At a charge there is the return reactions to which at the end of a charge reaction of water electrolysis is added being accompanied oxygen allocation on a positive electrode and hydrogen - on negative precede.

As a result it turns out that at the discharge of the battery sulfuric acid with simultaneous formation of water (and density of electrolyte falls) is spent and at a charge on the contrary, water is "consumed" for formation of sulfuric acid (density of electrolyte grows).

At the end of a charge at some critical values of concentration of lead sulphate at electrodes process of water electrolysis starts prevailing. Thus on the cathode hydrogen on the anode – oxygen is emitted. At a charge you shouldn't allow water electrolysis, otherwise it is necessary to add it.

## 2.7 GSM SIM800L Module

SIM800L is a quad-band GSM/GPRS module that works on frequencies GSM850MHz, EGSM900MHz, DSC1800MHz, and PCS1900MHz. SIM800L Features GPRS multi-slot class 12 / class 10 (optional) and supports the GPRS coding schemes CS-1, CS-2, CS-3 and CS-4.

### GSM SIM800L Module Features:

1. Supply voltage: 3.8V - 4.2V 2. Recommended supply voltage: 4V

3. Power consumption:

sleep mode < 2.0mA

idle mode < 7.0mA

GSM transmission (avg): 350 mA

GSM transmission (peek): 2000mA

Module size: 25 x 23 mm

Interface: UART (max. 2.8V) and AT commands

SIM card socket: microSIM (bottom side)

Supported frequencies: Quad Band (850 / 950 / 1800 /1900 MHz)

Antenna connector: IPX

Status signaling: LED

Working temperature range: -40 do + 85 °

Figure 3.9: Pin diagram of SIM800L Module

### SIM800L Arduino Circuit:

#### 3.7.1 Working Principle of GSM SIM800L Module:

SIM800L is a miniature cellular module which allows for GPRS transmission, sending and receiving SMS and making and receiving voice calls. Low cost and small footprint and quad band frequency support make this module perfect solution for any project that require long range connectivity.

#### 3.7.2 Applications of GSM SIM800L Module:

GSM SIM800L Module can feature all the functionalities of a mobile phone through computer like making and receiving calls, SMS, MMS etc. These are mainly employed for computer based SMS and MMS services. The GSM/GPRS module demonstrates the use of AT commands.

## CHAPTER-3

### Design and Fabrication

#### 3.1 CIRCUIT DIAGRAM OF THIS PROJECT

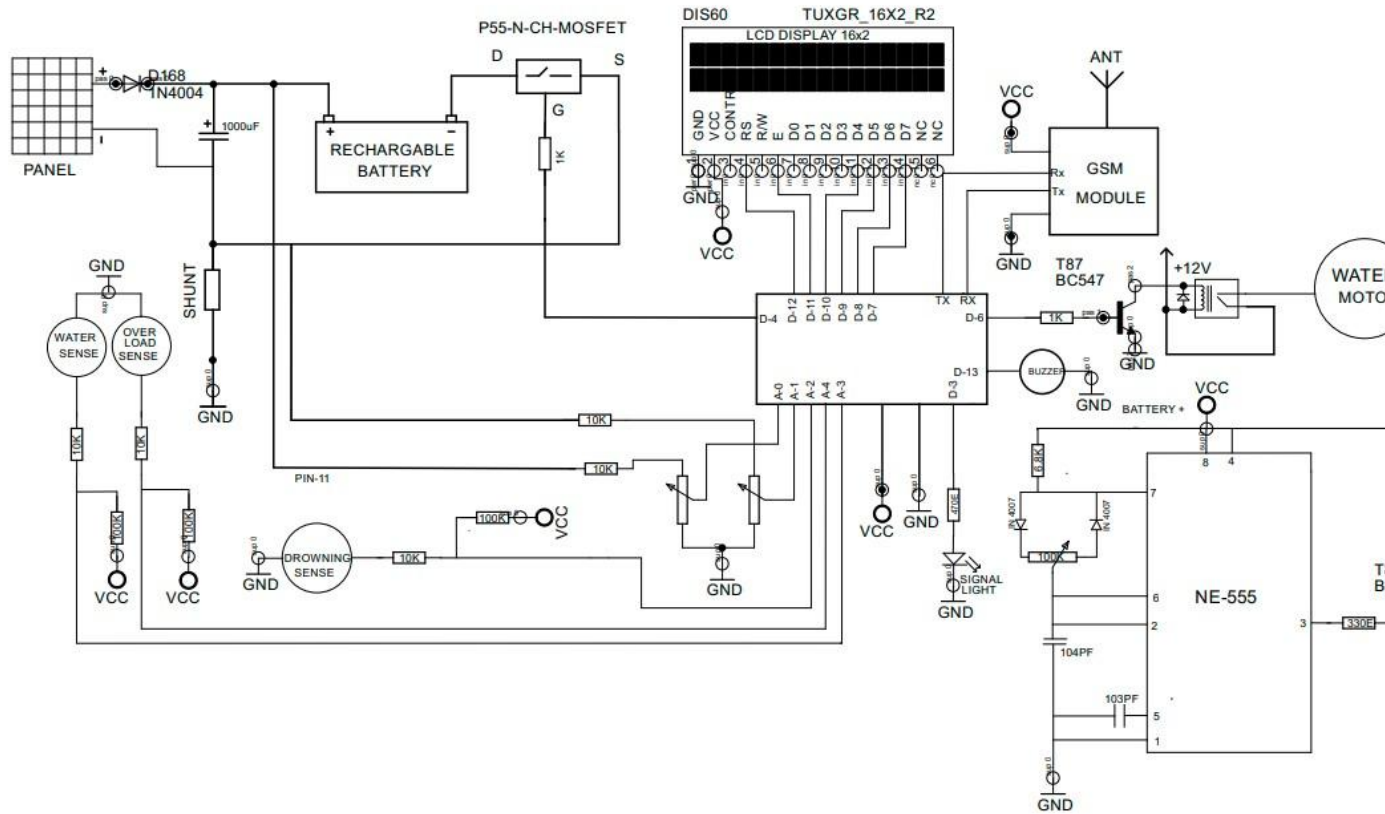

Figure 3. 1 Circuit Diagram

#### 3.2 BLOCK DIAGRAM OF THIS PROJECT

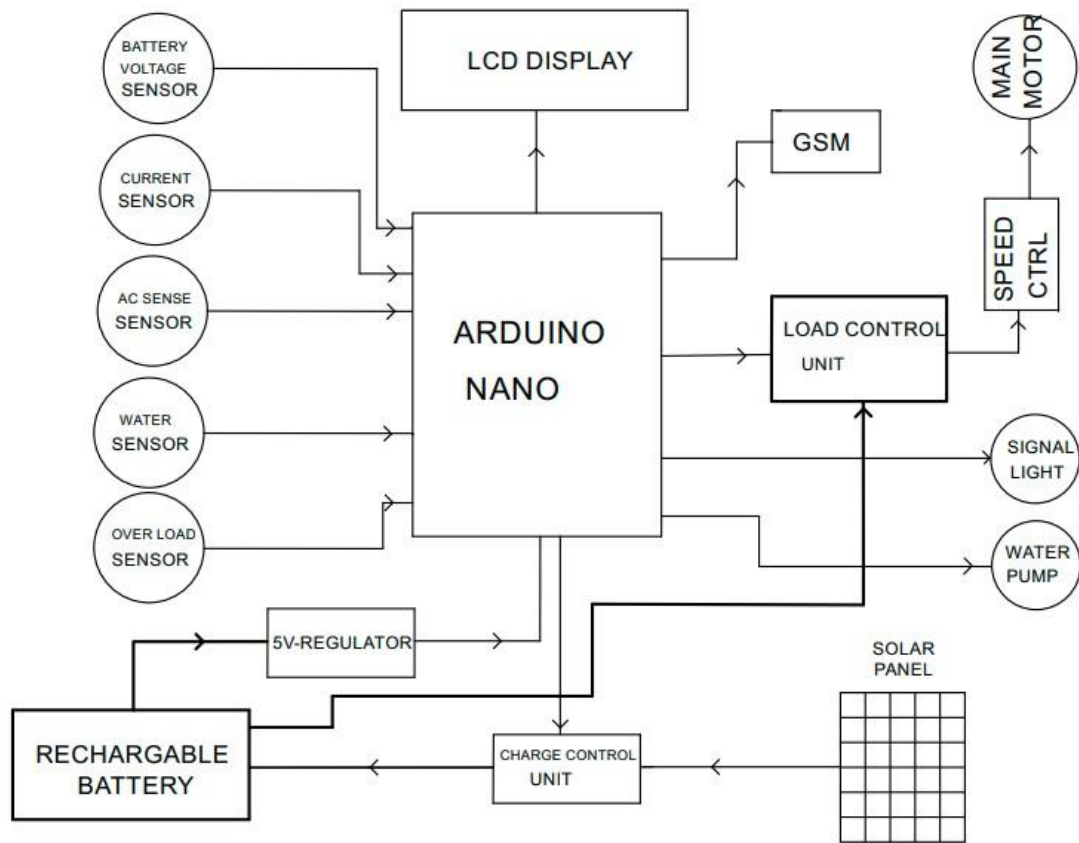

Figure 3. 2 Block Diagram

### 3.3 COMPONENT LIST:

SL	NAME	QTY
1.	SOLAR PANEL	2
2.	PIC 16F73 MICROCONTROLLER	1
3.	16X2 LCD DISPLAY	1
4.	16MHz CRYSTAL	1
5.	CAPACITOR-470uF/16V	1
6.	DIODE-SR560	1
7.	FET P55	1
8.	OPTOCOUPLAR	1
9.	7805 REGULATOR	1
10.	DC LIGHT	1
11.	RESISTOR- 1K,10K,100K,470E,	1
12.	12V TRANSFORMER	1
13.	555TIMER IC	1
14.	POWER SWITH	1
15.	12V DC MOTOR	1
16.	5V DC PUMP	1

### 3.4 Working principle

Solar electric powered boats may promote zero-emission aquatic transportation and recreation not only for Iowa lakes and rivers, but for all US and world waters. For three years the University of Northern Iowa (UNI) solar electric boat project has recruited students both from electrical and information engineering technology (EIET), and manufacturing technology majors. The problem defined by this paper is (1) developing a novel zero-emission boat, the progress and update on current and the last two years of design, and (2) representing UNI in the annual International Solar Boat World Championship. The race also includes competitions for outstanding workmanship, sportsmanship, outstanding technical report, commercially viable hull design, and outstanding solar system design. In June 2004, the UNI solar electric boat team won four trophies; (1) the most commercially viable hull design, (2) the fastest boat in qualifications, (3) the most improved team from the previous year, and (4) the ninth overall place in world championship. Senior students involved in this project have shown excellent progress by developing their technical and teamwork/social skills as part of the Senior Design I and II courses and successfully completing course requirements.

#### 3.4 Ship Environment

2.1. The Catamaran For our project we consider a ship with the following characteristics.

Catamaran

Maximum speed: 10 km/h (~8 kts)

Cruising range: 5 hours

Length over all: 14.00 m

Width: 5.50 m

Draft at full load: 0.9 m Besides we consider that: The ship is equipped with two 8 kW permanent magnet synchronous motors;

Normal cruising speeds equal to 8 km/h (~4 kts);

Boat travels for about 200 days per year (about 1000 hours of navigation for year);

Average electrical power required during the cruise 11 kW (average electrical energy consumption for year 11 MWh).

Not all ships are suitable targets for the integration with photovoltaic generating system. A solar-electric ship must have sufficient deck space. For the project we have chosen a catamaran. In our boat a flat top structure is proposed (see Figure 1) in order to maximize the area available for putting up a photovoltaic array.

##### 3.4.1 Batteries

For our ship, we assume that the average electrical power necessary during the cruise is 11 kW and the maximum peak power is 22 kW. To get a system that can ensure a reliable transport, we must assume that the energy, used during the cruise (5 h), must be entirely taken from the batteries; for designing in safety, we have to hypothesize that the photovoltaic system doesn't supply energy. Therefore, the daily energy consumption that the batteries have to provide is equal to the average power (11 kW) for half cruise time (2.5 hours), while in the other half, we consider an emergency situation during which, is required the maximum power (22 kW) to ensure the fastest return journey to the harbor. With all these hypotheses, the total storage battery capacity has to be >82 kWh. Figure 2 shows the electrical load during a typical day without return in emergency. Furthermore, we have to hypothesize the necessity to charge the batteries during the docking time. To fulfil this task, an access to the industrial grid connection (400 V), on the pier, is necessary. Rectifying the grid tension is possible to ensure an effective DC voltage of 550 V. For our project, we have chosen the batteries Valence U27-36XP model.

Specifications of Battery model lithium yon Voltage (Vo) 12.4 V Normal Capacity 24 Ah Weight 19.6 kg Dimension 306 × 172 × 225 mm Standard discharge (Vcoff , Id) 10 V, 24 A Standard charge (Vch, Ich) 14 V , 24 A DC internal resistance 25 mΩ

If, we consider a system structure of four battery banks (BM1, BM2, BM3 and BM4), as mentioned earlier, the BMx bank must be compatible with the charging voltage of 550V, so we need a series of N batteries:

The maximum necessary current for a return in emergency of the boat is:

Bus 22 kW/DC 44 A . In conclusion we have considered a system made by 52 batteries (four battery banks), with these features: □ Total weight:  $52 \times 19.6 \text{ kg} \approx 1020 \text{ kg}$  □ Volume:  $0.306 \times 0.172 \times 0.225 \times 52 \approx 0.6 \text{ m}^3$  □ Maximum electrical energy storage  $\approx 90 \text{ MWh}$ . The weight of the electric drive system is lower and more efficient to distribute in the hull than a classical system, therefore the drive unit is small and the batteries can be distributed somewhat flexibly and it is possible to divide them between the catamaran hulls. Comparing the whole weight of electric system with diesel systems, including all batteries, PV array, generators, fuel and the electric system comes out either heavier, lighter, de-pending on the assumptions of fuel, or the same. Not surprisingly, since the technology is not being manufactured in high volume, the first cost of the electric system, including installation is higher than the equivalent diesel one, for about 30%, but it must be considered that prices are very likely to come down with time. Another advantage of the electric system is to have “instant power”. There is no need to wait for the engine to warm up; there is no gearbox to engage, it’s sufficient to turn on and go. Instant reverse is available too; one can go from full power forward to full reverse in an instant for a very abrupt emergency stop.

### 3.5 Conclusion

This chapter we discussed about circuit diagram and block diagram and working principle also.

## Chapter-4

### Result and Discussion

#### 4.1 Introduction

In this Chapter We write about our project result and success. First of all we want to thank our God. Then we want to thanks to our supervisor sir for help us.

#### 4.2 Result

We successfully complete our project and got all output.

There have a charging control unit that automatically cut-off charging when battery full charged.

The signal light automatically on after sunset.

Water pump automatically on when water inter inside the boat.

We got overload signal after 20 second when boat is overloaded.

We got boat sink signal after 30 second when boat is sinking.

#### 4.3 Advantages

There has no other cost like diesel or patrol cost.

Low maintenance cost.

No need electricity bill.

Tension free for about 10 year.

#### 4.4 Disadvantages

Need manually drive when battery charge will finished.

Initial production cost hi.

Need extra power when weather is not good.

#### 4.5 Applications

Passenger carrying.

Fishing

For Navy.

For Cost guard.

Tourist carrying.

#### 4.6 Discussion

Many protected areas in the world are facing the growth of tourism pressure; the same problem is present in the areas of naturalistic interest. Tourism is seen as a viable financial option for protected areas with the tourism concessions, through private sector partnerships, that permitted to gaining momentum and that allows the over-arching goal of preservation and conservation to remain with the state. However, without appropriate planning or best practices in place, tourism concessions can lead to such problems as waste, habitat destruction and the displacement of local people and wildlife. In other words, tourism brings economic benefits to countries, but there are usually substantial socio-economic and environmental costs associated with it.



#### **4.7 Management Control**

The principal assignment of the management control system is to determine the real available energy for the navigation and to furnish information on the ship autonomy. To realize this assignment, the system preserves information of the flows of energy and manages the complete discharge/charge of the battery banks. The performances of all electrical systems are monitored by the management control. It manages the discharge of the single battery bank one at a time. With this management strategy we check the battery life and limit the number of charge/discharge. In our system, the sizing of battery capacity has been selected in such a way that, with an opportune control, at most only one cycle of charge/discharge could be done during the navigation. Considering that our batteries bear 2000 complete discharges with a loss within the 20% the time life of the batteries will be greater than 10 years.

## Chapter-5

### Conclusion And Future Work

#### 5.1 Conclusion

The design of a Solar-Electric Boat for tourists' transport along the coast, in the rivers, in the lakes has been presented. With our system, it is possible to replace the standard fuel engine with an electric one, by accepting a loss in power, and without changing the weight and the dimension of the boat. Our boat has greater price in comparison to an equivalent boat equipped with traditional propulsion. Currently to manufacture a solar-electric boat there are extra cost due to photovoltaic plant, battery bank and management control system. These additional costs are partially compensated by reduction of operation costs; in solar-electric boat there is no consumption of fuel and the costs of maintenances are relatively lower. In our boat, the initial additional cost is about of 50,000\$. On the other hand, the annual saving on the exercise is estimable in 5000\$; within ten years the extras costs are amortized. Besides, the great advantage of the use of renewable energy produces indirect socio-economic advantages; ecosystem preservation, reduction of CO<sub>2</sub>, NO<sub>x</sub> and SO<sub>x</sub> emission, etc

#### 5.2 Future Work

The boat has quite a bit of potential for future extension, from changes to the control logic through to fitting out as a monitoring platform.

##### 5.2.1 Use attitude information

As the core controller is designed as an aircraft controller, it has a pitch/roll information that is currently unused by the control code. This information could be used to gain assistance from the ocean swell (effectively surfing), or to avoid capsizing by facing into oncoming waves when they get too large, and in the even of a capsize - to turn off the motors and indicate distress to the ground station.

##### 5.2.2 Collate and present telemetry

The current version of the telemetry server just logs the position, and doesn't support sending updates to the boat. A future task is to take this logged information and display it in a userfriendly manner (and allow updating the mission while the craft is at sea).

##### 5.2.2 Alternate power storage

As noted earlier, the boat's current power storage capacity is well underneath the daily generation of the solar panel, which means that the craft will most likely have to reduce power during the night (or cut off all together). Adding more SLA batteries, or even switching to a more complex power solution, would allow longer continuous operation, and may lead to an improvement in range.

### 5.2.3 Advanced power monitoring

The only aspect of power that is currently being monitored is the battery charge level (through a basic resistor divider feeding into an analogue input on the microcontroller).

Adding other sensors (e.g. battery current, solar panel voltage) would aid in system monitoring (detecting actual motor load, and determining if the solar panel has been fouled). Another potential self-monitoring sensor would be a moisture sensor within the hull, allowing the craft to report if it has sprung a leak (it may not have anything it could do in that case, but such an indication could be useful for forensic purposes).

### 5.2.4 External sensing equipment

As this craft is designed to be able to cross large stretches of water without human interaction, it is the ideal location to place various sensors to measure various aspects of the ocean surface. Options include a basic "CTD" (conductivity, temperature, and depth) sensor, wind speed sensor, or even a full-blown camera. However, with any sensor comes the requirement to extract the recorded data, which ideally would be done by sending over the telemetry channel, which would require integration with the autopilot board (which may be separate to the data collection board).

### 5.3 Definitions

**ESC-** Electronic Speed Controller - A type of motor controller used for brush-less electric motors, typically takes a servo-style PWM signal (1-2 microsecond pulses with a period of 125ms) as input.

**PWM-** Pulse-Width Modulation - Digital signalling method involving sending periodic logic-high signals of varying duration (at a fixed period) to indicate a range of values.

**PVC-** PolyVinyl Chloride - Common plastic polymer, typically used in various forms of piping (notably plumbing and electrical).

**Wh-** Watt-Hour - A measure of electrical energy representing the amount of energy from a device operating at 100W for an hour, equal to 3600 joules.

**SLA-** Sealed Lead-Acid (battery) - A form of lead-acid battery that is completely sealed (not requiring top-up as many automobile batteries do).

**TCP/IP** Transmission Control Protocol / Internet Protocol - Suite of data transmission protocols used to transmit data between two points on the internet.

## REFERENCES:

1. M. Wyman, J. R. Barborak, N. Inamdar and T. "Stein, Best Practices for Tourism Concessions in Protected Areas: A Review of the Field," *Forests*, Vol. 2, No. 4, 2011, pp. 913-928. doi:10.3390/f2040913
2. J. Davenport and J. L. Davenport, "The Impact of Tourism and Personal Leisure Transport on Coastal Environments: A Review Estuarine," *Coastal and Shelf Science*, Vol. 67, No. 1-2, 2006, pp. 280-292. doi:10.1016/j.ecss.2005.11.026
3. J. L. F. Soto, R. G. Seijo, J. A. Formoso, G. Iglesias and L. C. Couce, "Alternative Sources of Energy in Shipping," *Journal of Navigation*, Vol. 63, No. 1-2, 2010, pp. 435- 448. doi:10.1017/S0373463310000111
4. K. Hochkirch and V. Bertram, "Options for Fuel Saving for Ships," *Mare Forum 2010: Maritime Transportation of Energy*, Houston, 19 February 2010.
5. G. Schirripa, Spagnolo, D. Papalillo and A. Martocchia, "Eco friendly Electric Propulsion Boat," 10th International. Conference on Environment and Electrical Engineering, Rome, 8-11 May 2011, pp. 1-4. doi:10.1109/EEEIC.2011.58746P.  
Letellier, "High Power Permanent Magnet Machines for Electric Propulsion Drives," *Proceedings of 3rd International Symposium on All Electric Ship*, Paris, 27 October 2000, pp. 126-132.
6. F. Gieras and M. Wing, "Permanent Magnet Motor Technology," Marcel Dekker Inc., New York, 1997.
7. S. D. Sudhoff, "Currents of Change Electric Ship Propulsion Systems," *IEEE Power & Energy Magazine*, Vol. 9, No. 4, 2011, pp. 30-37. doi:10.1109/MPE.2011.941319
8. <http://oceanshaker.com/2010/07/07/suncat-46-the-first-ser ial-luxury-catamaranpowered-by-100-solar-energy>
9. [http://www.solarnavigator.net/transatlantic\\_21.htm](http://www.solarnavigator.net/transatlantic_21.htm)
10. R. A. Dunstan, "Smart Battery Providing Battery Life and
11. Recharge Time Prediction," US Patent No. 5565759, 1996.
12. M. C. Smart, B. V. Ratnakumar, K. B. Chin, L. D. Whitcanack, E. D. Davies, S. Surampudi, M. A. Manzo and P. J. Dalton, "Lithium-Ion Cell Technology Demonstration for Future NASA," 37th Intersociety Energy Conversion Engineering Conference 2002, Washington DC, 29-31 July 2002, pp. 297-304. doi:10.1109/IECEC.2002.1392029
13. X. Weidong, N. Ozog and W. G. Dunford, "Topology Study of Photovoltaic Interface for Maximum Power Point Tracking," *IEEE Transactions on Industrial Electronics*, Vol. 42, No. 3, 2007, pp. 1696-1704. doi:10.1109/TIE.2007.894732
14. C. Wang, W. Chen, S. Shao, Z. Chen, B. Zhu and H. Li, "Energy Management of Stand-Alone Hybrid PV System," *Energy Procedia*, Vol. 12, 2011, pp. 471-479. doi:10.1016/j.egypro.2011.10.063