

Design and Fabrication of an Evaporative Cooling System

A report submitted to the Department of Mechanical Engineering, Sonargaon University of Bangladesh in partial fulfillment of the requirements for the Award of Degree of Bachelor of Science in Mechanical Engineering.

Submitted by

Sydur Rahman Emon	ID: BME 1901017164
Shohel Hossen	ID: BME 1901017070
Md Mainul Hossain	ID: BME 1901017089
Riton Acharjya	ID: BME 1901017163



Supervised by

Nuruzzaman Rakib
Lecturer

Department of Mechanical Engineering

Sonargaon University (SU)

September, 2022

ACKNOWLEDGEMENT

First we started in the name of almighty Allah. This thesis is accomplished under the supervision of **Nuruzzaman Rakib**, Lecturer, Department of Mechanical Engineering, Sonargaon University. It is a great pleasure to acknowledge our profound gratitude and respect to our supervisor for this consistent guidance, encouragement, helpful suggestion, constructive criticism and endless patience through the progress of this work. The successful completion of this thesis would not have been possible without his persistent motivation and continuous guidance.

The author are also grateful to Md. Mostofa Hossain , Head of the Department of Mechanical Engineering and all respect teachers of the Mechanical Engineering Department for their co-operation and significant help for completing the thesis work successfully.

[Authors]

Sydur Rahman Emon

ID: BME 1901017164

Shohel Hossen

ID: BME 1901017070

Md Mainul Hossain

ID: BME 1901017089

Riton Acharjya

ID: BME 1901017163

ABSTRACT

Evaporative cooling is an energy efficient and environmentally friendly air conditioning technology. Evaporative cooling has a great many advantages over other cooling processes. Due to the non-pollution creating environment. It is considered as one of the suitable ways to cool ones workplace or living place, because of the fact that it uses fresh air and replaces the air. It is based on a natural process of air cooling by water, it won't dry out the air, or irritate human skin, eyes, or other external parts of the human body. Moreover, evaporative cooling is an inexpensive cooling option which enhances the lifestyle of people. However, evaporative cooling requires an abundant water and is efficient when the relative humidity is low. Always an attempt is made to obtain the saturation efficiency at optimum water consumption rate. The feasibilities of evaporative cooling under different climates, efficiencies of various evaporative cooling equipment's and critical parameters and techniques for improving the efficiencies as well as numerical modeling of evaporative cooling processes.

TABLE OF CONTENTS

Acknowledgement		ii
Abstract		iii
CHAPTER-1	INTRODUCTION	1-2
1.1 Introduction		1
1.2 Objectives		2
1.3 Organization of Book		2
CHAPTER-2	LITERATURE REVIEW	3-5
2.1 Literature Review		3
CHAPTER-3	METHODOLOGY	6-8
3.1 History		6
3.2 Principle Evaporator Cooling		6
3.3 Methodology		7
CHAPTER-4	DESIGN	9-10
4.1 Block Diagram		9
4.2 Components List		9
4.3 Cost List		10
CHAPTER-5	CONSTRUCTION	11-24
5.1 SMPS		11
5.2 Evaporator		16
5.3 Pump Motor		20
5.4 Cooling Fan		21
5.5 Complete Project Image		22
CHAPTER-6	EXPERIMENTAL RESULT	25
6.1 Result		25

CHAPTER-7	DISCUSSION	26-27
7.1 Discussion		26
7.2 Advantages		26
7.3 Applications		26
7.4 Limitations		27
CHAPTER-8	CONCLUSION	
8.1 Conclusion		28
8.2 Future Scope		28
Reference		29

LIST OF FIGURES

FIGURE NO	FIGURE NAME	PAGE NO
3.1	Evaporative Cooling Working Principle	6
3.2	Working Principle of Evaporator Cooling System	7
4.1	Block Diagram of Evaporator Cooling System	9
5.1	SMPS	11
5.2	SMPS Circuit Diagram	13
5.3	Power Supply Connection	15
5.4	DC Power Supply Step	16
5.5	Bare Tube Evaporator	18
5.6	Plate Evaporator	19
5.7	Finned Tube Evaporator	20
5.8	Pump Motor	20
5.9	Cooling Fan	21
5.10	Evaporator Pad	22
5.11	Evaporator Water Storage	23
5.12	Exhaust Fan	23
5.13	Project Prototype Image	24

CHAPTER 1

INTRODUCTION

1.1 Introduction

Evaporative cooling is a physical phenomenon in which evaporation of a liquid, typically into surrounding air, cools an object or a liquid in contact with it [1-4]. Evaporative cooling occurs when air, that is not too humid, passes over a wet surface, the faster the rate of evaporation the greater the cooling. It brings the comfort by increasing the humidity in dry climates, improves the air quality, and makes the air more breathable. The most familiar example of this is cooling effect of evaporating perspiration on the human skin. In dry hot climates body temperature is partially controlled by the rapid evaporation of perspiration from the surface of the skin. [2-5] The evaporation rate is raised as air movement is increased. Both of these facts can be applied to natural cooling of structures. This evaporation results in a reduced temperature and an increased vapor content in the air. The bigger the area of contact between the air and water the more evaporation occurs, resulting in more cooling and the addition of moisture. [6-8].

In the fundamental basis for understanding any air conditioning, dehumidification and evaporative cooling is *psychometrics*. It consists of the interaction between heat, moisture and air. It is basically the study of air water mixture and is an essential foundation for understanding how to change air from one condition to another to rises its capacity to hold moisture. This makes moisture a very influential factor for heat gain, both for comfort and in calculation. The knowledge of the system consisting of a dry air and water vapor is essential for the design and analysis of air conditioning devices, cooling towers and industrial processes which requiring close control of the vapor content in air. Air moisture and heat interaction fortunately, this interaction can be combined in a single chart. This rate of evaporation of water purely depends on the temperature humidity of the air as well as the pressure of the particular place. Hence, sweat accumulates more on hot humid days in which the perspiration is impossible to evaporate. Energy demand worldwide for building cooling has increased sharply in the last few decades, which has raised concerns over depletion of energy resources and contributing to global warming. Current energy demand estimates stand at between 40 and 50% of total primary power consumption. In hot climate countries, the

highest share of building energy use is mainly due to space air conditioning using traditional HVAC systems [8-10].

1.2 Objective:

The objectives of this project are:

- To Design an Evaporative Cooling System.
- To Analysis the Cost of Evaporative Cooling System
- To implement an Evaporator Cooling System.
- To test the performance of the cooling system.

1.3 Organization of Book

This project book consists of five chapter. The first chapter contains the statement of the introduction, objectives of the study and the project organization. Chapter two contains literature review in details. Chapter three describes the project theory and working principle, , working principle and shows the complete prototype of the project that we have built.. Chapter four deals with the result and discussion. In the final chapter, we have conclusion and future work of the project and also about some aspects we had to overcome while doing the project and lastly, we gave the conclusion of the book.

CHAPTER 2

LITERATURE REVIEW

2.1 LITRATURE REVIEW

JOURNAL OF ENVIRONMENTAL RESEARCH AND DEVELOPMENT “Design of Air Cooling System for College Auditorium”,S.S. Wane and M.B. Nagadeve, Dr. Punjabrao Deshmukh Krushi Vidhyapeeth, Akola Maharashtra: In this paper we are going to explain the design of centralized air cooling system for college auditorium. The present building of college auditorium posed the problem of ill-ventilated atmosphere and suffocation in most of its part during the programs. Major part of the building exposed to the sun the roof being heated throughout the day. The object of air cooling is to establish a stable thermal environment which satisfies the majority of occupants with respect to comfort under all the climatic conditions to which the building is subjected.

Hence it was decided to provide the false ceiling and design air cooling system for college Auditorium for better comforts to the occupants during longer program. For the cooling system of auditorium requires two coolers with water requirement is estimated as 8 lit/sec and power requirement is 120 Watts. Solar and transmission heat gain through walls and roofs etc. Solar and transmission heat gain through doors, windows or wall glasses. Transmission gain through partition wall ceiling floor etc. Infiltration of direct air from some inlets like doors or windows. Internal heat gain from occupants, light appliances etc. Additional heat gain not accounted above, safety factors etc. Return duct heat gains, supply duct leakage, heat gain from door, fan and pump.[1]

INTERNATIONAL JOURNAL OF EMERGING TECHNOLOGY AND ADVANCED ENGINEERING “Design Optimization and Installation of the Evaporative Cooler.”, Md. Almost Asim Mahmud, Dr. Md. Alamgir Hossain, M.A. Muktadir : This Evaporative cooling is an environmentally friendly air cooling system that operates using induced processes of heat and mass transfer, where water and air are the working fluids. It consists, specifically, in water evaporation, induced by the passage of an air flow, thus decreasing the air temperature.

In Bangladesh, Evaporative cooler is already being used in different industries that is imported from various countries. But most of the cases these are not efficient due to installation error & lack of adjustment with climate change over the year. Initially this paper presents the construction of an evaporative cooler using a test bench of cooling tower for the air flow and water supply facility where local materials were used as evaporative pad. Afterwards; it presents installation in different situation & adjustment of the cooling units with the climate. It concludes that under proper installation, evaporative cooling system is very cost effective & has a very large potential to propagate thermal comfort and can still be used as an alternative to conventional systems in regions where the design wet bulb temperature is low.[2]

DESIGN OF AN AIR DISTRIBUTION SYSTEM FOR A MULTI-STORY OFFICE BUILDING

By- Dave Janquart: Earlier the use of air conditioning for comfort purpose was considered to be expensive, but now-a-days, it has been a necessity for all human beings. Window air conditioners, split air conditioners are used in small buildings, offices etc. But, when the cooling load required is very high such as big buildings, multiplex, multi-story buildings, hospitals etc. centralized unit (central air conditioners) used. The central AC's systems are installed away from building called central plant where water or air is to be cooled. This cooled air not directly supplied to the building rooms. When the cooled air cannot be supplied directly from the air conditioning equipment to the space to be cooled, then the ducts are provided. The duct systems carry the cooled air from the air conditioning equipment for the proper distribution to rooms and also carry the return air from the room back to the air conditioning equipment for recirculation.

When ducts are not properly designed, then it will lead to problem such as frictional loss, higher installation cost, increased noise and power consumption, uneven cooling in the cooling space. For minimizing this problem, a proper design of duct is needed. Equal friction method is used to design the duct, which is simple method as compared with the other design methods. The duct design for TIIR building is done, by using equal friction method. All values are comparable with duct software called ductular. The calculated value of frictional is less or near as calculated by software. Due to less value of friction drop, duct diameter is increased but loss in total pressure (i.e. static pressure, velocity pressure) can be avoided. Due to increased duct diameter the use of damper may be decreased.

Also the circular duct can carry more air in less space, because of that, less duct material, less duct surface friction and less insulation is required. Pressure loss in duct fitting can be minimized by proper design the elbow shape. Ansys 13.0 software is used to analyze the pressure loss in circular and rectangular duct. After analysis we conclude that the circular duct has minimum friction loss, so it is better shape for ducting.[3]

CHAPTER 3

METHODOLOGY

3.1 History

This evaporator cooling system is so effective and safe process. It is mainly used in home, hospital, factory and industrial area. After it used, we reduce the cost of money to cool air. That's way we get good efficiency. Where very cost effective to buy air-condition but our system is reducing the cost. This machine is very easy to use and it works very effectively. A working procedure relevant image is added below –

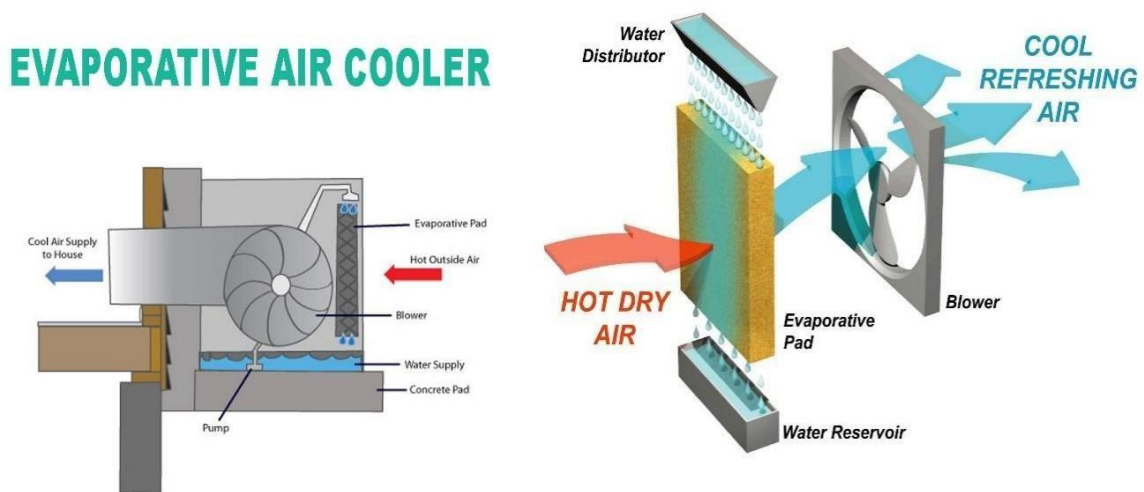

Figure 3.1: Evaporator Cooling Working Principle..

3.2 PRINCIPLES OF EVAPORATIVE COOLING

When trying to understand evaporative cooling, it may be the best to think of air as being like a sponge or cooling pads, in that regard, air has an ability to absorb moisture that it come in contact with. The amount of moisture that the air will absorb depends on the state of air and the temperature of the air. If the air is warm and contains only a small amount of moisture, it will more radially absorb moisture. As air cools, it volumes decreases, and with it, its ability to absorb moisture decreases. Cooling through evaporation is a natural occurrence and the most common we all experiences is perspiration, or sweat as perspiration evaporates, it

absorbs the heat to cool our body. It is a heat and mass transfer process that requires water for evaporation for the coolness in which heat is transferred from air to water and simultaneously the temperature of air decreases [7-9].

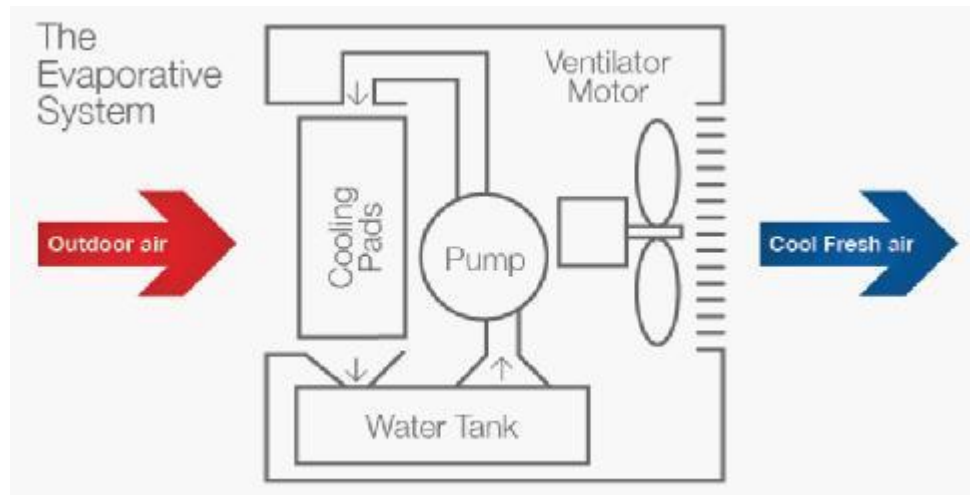

Figure 3.2: Working Principle of Evaporator Cooling System

The principle underlying evaporative cooling is the fact that water must have heat applied to it to change from liquid to vapor. When evaporation occurs, this heat is taken from the water that remains in the liquid state, resulting in a cooler liquid. The evaporative coolers are classified as:

- 1] Direct Evaporative [Working fluid as water and air in direct contact]
- 2] Indirect Evaporative cooler [Surface plates separates the working fluid].
- 3] Combination of both the Direct and Evaporative Coolers [With different cooling cycles][1]

3.3 Methodology

Our project is designed to evaporate of air. We are using soil moisture sensors, relays, pump motor and voltage regulator. Here the current from AC is entering the circuit at 5 volts via SMPS. SMPS is the main power converter of this system. Here we need fixed 5V dc current that's why we use this power supply.

An evaporative air cooler is a type of air conditioner that works by harnessing the power of evaporation to cool air temperatures. Here is a water tank in our system. Firstly we need to fill

water in this tank. From this tank a pump motor will calculate this water . Pump motor will take in evaporator water store. The water will flow down from the evaporator and with the help of an exhaust fan the air will cool down and cool the air in front. Here the exhaust fan with hot air will blow air through the evaporator to the front. As a result of this hot air in contact with water, this air will actually cool down and flow forward. Thus the evaporator system cools the air. This is the main process of our system.

CHAPTER 4

DESIGN

4.1 Block Diagram:

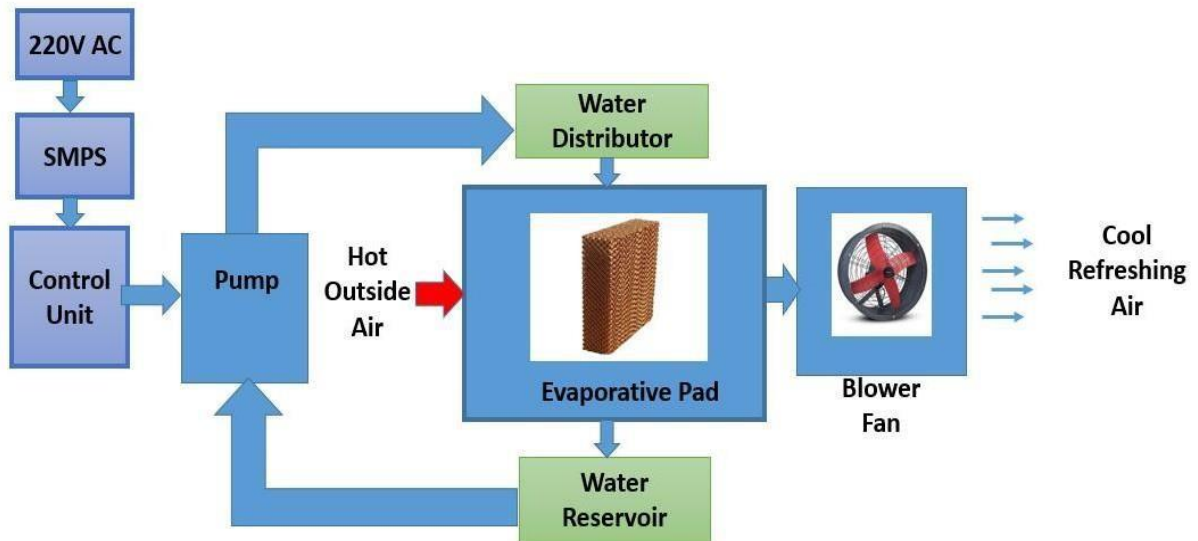

Figure 4.1: Block Diagram of Evaporative Cooling System.

4.2 Components List:

1. SMPS (Switch Mode Power Supply)
2. DC Pump Motor
3. Evaporator Pad
4. Wire
5. Blower Fan
6. Switch
7. Body Structure Material

4.3 Cost Analysis:

No	Product Name	Specification	Qty	Unit Price	Total Price	Market Price
01.	SMPS	5V 7Amp	1	450	450	
02.	Pump	DC	1	120	120	
03.	Evaporator	Pad	1	1100	1100	
05.	Blower Fan	12V DC	1	850	850	
10.	Others				1500	
					2520/=	4500/=

Table 1: Cost Analysis.

CHAPTER 5

CONSTRUCTION

5.1 Switch Mode Power Supply (SMPS):

A switched-mode power supply (switching-mode power supply, switch-mode power supply, switched power supply, SMPS, or switcher) is an electronic power supply that incorporates a switching regulator to convert electrical power efficiently. Like other power supplies, an SMPS transfers power from a DC or AC source (often mains power) to DC loads, such as a personal computer, while converting voltage and current characteristics.

Unlike a linear power supply, the pass transistor of a switching-mode supply continually switches between low-dissipation, full-on and full-off states, and spends very little time in the high dissipation transitions, which minimizes wasted energy. A hypothetical ideal switched-mode power supply dissipates no power. Voltage regulation is achieved by varying the ratio of on-to-off time (also known as duty cycles). In contrast, a linear power supply regulates the output voltage by continually dissipating power in the pass transistor. This higher power conversion efficiency is an important advantage of a switched-mode power supply. Switched-mode power supplies may also be substantially smaller and lighter than a linear supply due to the smaller transformer size and weight.



Figure 5.1: SMPS

Switching regulators are used as replacements for linear regulators when higher efficiency, smaller size or lighter weight are required. They are, however, more complicated; their switching currents can cause electrical noise problems if not carefully suppressed, and simple designs may have a poor power factor.

12V 5A Industrial SMPS Power Supply – 60W – DC Metal Power Supply – Good Quality – Non Waterproof with Aluminum casing.

- Input Voltage: AC 100 – 264V 50 / 60Hz
- Output Voltage: 12V DC, 0-5A
- Output voltage: Adjustment Range: $\pm 20\%$
- Protections: Overload / Over Voltage / Short Circuit
- Auto-Recovery After Protection
- Universal AC input / Full range
- 100% Full Load Burn-in Test
- Cooling by Free Air Convection
- High Quality and High Performance
- LED power supply with a metal body for hidden installation for LED lighting
- Design with Built-in EMI Filter, improve signal precision.
- Certifications: CE & RoHs
- No Minimum Load.
- Compact Size Light Weight.
- High Efficiency, Reliability & low energy consumption
- Category – Switch Mode Power Adaptor (SMPS)

Switched-mode power supplies are classified according to the type of input and output voltages. The four major categories are:

- AC to DC
- DC to DC
- DC to AC
- AC to AC

A basic isolated AC to DC switched-mode power supply consists of:

- Input rectifier and filter
- Inverter consisting of switching devices such as MOSFETs
- Transformer
- Output rectifier and filter
- Feedback and control circuit

The input DC supply from a rectifier or battery is fed to the inverter where it is turned on and off at high frequencies of between 20 KHz and 200 KHz by the switching MOSFET or power transistors. The high-frequency voltage pulses from the inverter are fed to the transformer primary winding, and the secondary AC output is rectified and smoothed to produce the required DC voltages. A feedback circuit monitors the output voltage and instructs the control circuit to adjust the duty cycle to maintain the output at the desired level.

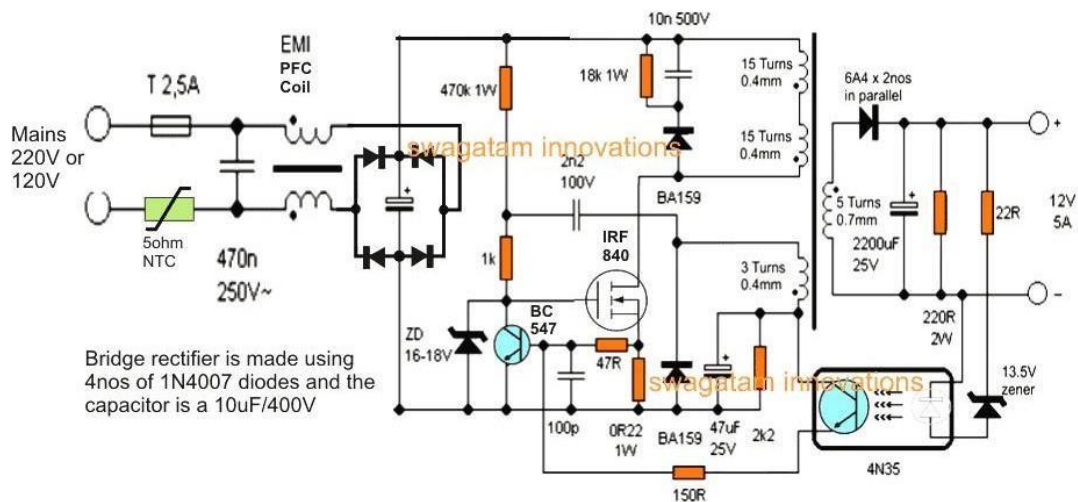

Figure 5.2: SMPS Circuit Design

Basic working concept of an SMPS

A switching regulator does the regulation in the SMPS. A series switching element turns the current supply to a smoothing capacitor on and off. The voltage on the capacitor controls the

time the series element is turned. The continuous switching of the capacitor maintains the voltage at the required level.

Design basics

AC power first passes through fuses and a line filter. Then it is rectified by a full-wave bridge rectifier. The rectified voltage is next applied to the power factor correction (PFC) pre-regulator followed by the downstream DC-DC converter(s). Most computers and small appliances use the International Electro technical Commission (IEC) style input connector. As for output connectors and pin outs, except for some industries, such as PC and compact PCI, in general, they are not standardized and are left up to the manufacturer.

There are different circuit configurations known as topologies, each having unique characteristics, advantages and modes of operation, which determines how the input power is transferred to the output. Most of the commonly used topologies such as fly back, push-pull, half bridge and full bridge, consist of a transformer to provide isolation, voltage scaling, and multiple output voltages. The non-isolated configurations do not have a transformer and the power conversion is provided by the inductive energy transfer.

Advantages of switched-mode power supplies:

- Higher efficiency of 68% to 90%
- Regulated and reliable outputs regardless of variations in input supply voltage
- Small size and lighter
- Flexible technology
- High power density

Disadvantages:

- Generates electromagnetic interference
- Complex circuit design
- Expensive compared to linear supplies

Switched-mode power supplies are used to power a wide variety of equipment such as computers, sensitive electronics, battery-operated devices and other equipment requiring high efficiency.

Switch Mode Power Supply

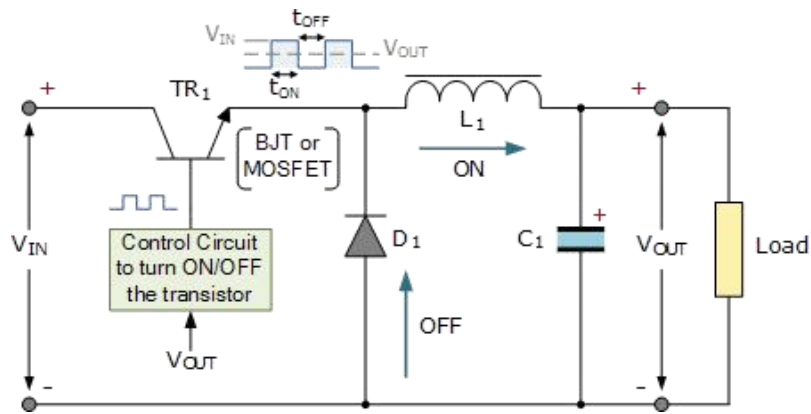

Figure 5.3: Power Supply Connection

Linear voltage IC regulators have been the basis of power supply designs for many years as they are very good at supplying a continuous fixed voltage output. Linear voltage regulators are generally much more efficient and easier to use than equivalent voltage regulator circuits made from discrete components such as a zener diode and a resistor, or transistors and even op-amps. The most popular linear and fixed output voltage regulator types are by far the 78... positive output voltage series, and the 79 negative output voltage series. These two types of complementary voltage regulators produce a precise and stable voltage output ranging from about 5 volts up to about 24 volts for use in many electronic circuits.

There is a wide range of these three-terminal fixed voltage regulators available each with its own built-in voltage regulation and current limiting circuits. This allows us to create a whole host of different power supply rails and outputs, either single or dual supply, suitable for most electronic circuits and applications. There are even variable voltage linear regulators available as well providing an output voltage which is continually variable from just above zero to a few volts below its maximum voltage output.

Most D.C. power supplies comprise of a large and heavy step-down mains transformer, diode rectification, either full-wave or half-wave, a filter circuit to remove any ripple content from

the rectified D.C. producing a suitably smooth D.C. voltage, and some form of voltage regulator or stabilizer circuit, either linear or switching to ensure the correct regulation of the power supplies output voltage under varying load conditions. Then a typical D.C. power supply would look something like this:

Typical DC Power Supply

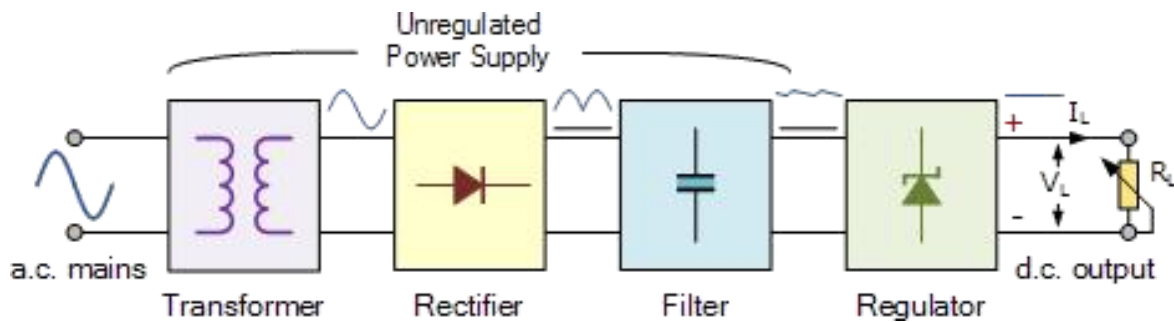

Figure 5.4: DC Power Supply Step

These typical power supply designs contain a large mains transformer (which also provides isolation between the input and output) and a dissipative series regulator circuit. The regulator circuit could consist of a single zener diode or a three-terminal linear series regulator to produce the required output voltage. The advantage of a linear regulator is that the power supply circuit only needs an input capacitor, output capacitor and some feedback resistors to set the output voltage.

5.2 Evaporators

Introduction Evaporation and evaporation are two processes in which simultaneous heat and mass transfer process occurs resulting into separation of vapor from a solution. Evaporation and vaporization occur where molecules obtain enough energy to escape as vapor from a solution. The rate of escape of the surface molecules depends primarily upon the temperature of the liquid, the temperature of the surroundings, the pressure above the liquid, surface area and rate of heat propagation to product.

Working Principle of Evaporator and its Types

The function of evaporator is to absorb heat from surrounding location or medium which is to be cooled by means of refrigerant. The refrigerant either boils as it flows through a pipe, tube or other type of space so that liquid is continuously wetting all the inside surface or it boils in a shell around submerged tubes through which the fluid to be cooling is flowing. Various methods are used for evaporators, depending upon the refrigerant to be used and evaporator application, but iron, steel and copper predominate. Refrigerant evaporators should be of extended surface or finned tube type whatever practical. In order to keep the average surface temperature down, a good bond between the fin and tube is essential. Integral fins formed out of the tube itself are best in this respect and give the best heat transfer rate.

Type of evaporators based on operating condition:

1. Flooded type evaporator
2. Dry or direct expansion type evaporator

Type of evaporator based on construction:

1. Bare tube evaporator
2. Plate evaporator
3. Finned tube evaporator
4. Shell tube evaporator
5. Tube in tube evaporator

Bare tube evaporator:

The bare tube evaporators are made up of copper tubing or steel pipes. The copper tubing is used for small evaporators where the refrigerant other than ammonia is used while the steel pipes are used with the large evaporators that uses ammonia as refrigerants. The evaporator comprises of several turns of tubing and are usually used for liquid chilling. In blast cooling and freezing operations, atmospheric air flows over bare tube evaporator and the chilled air leaving it used for cooling purposes.

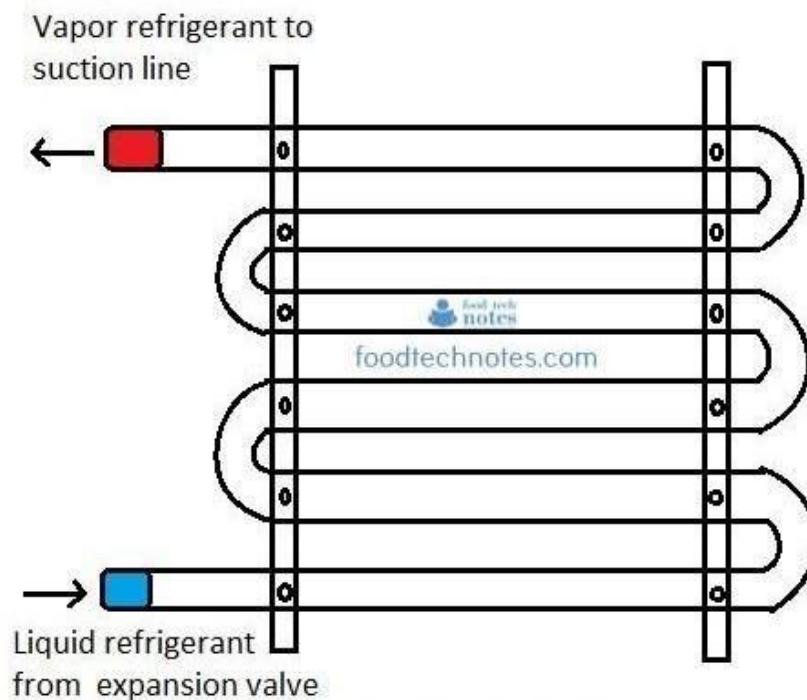

Figure 5.5: Bare Tube Evaporator

Plate evaporators: In plate type evaporators, the coil usually made of copper or aluminum is embedded in the plate so as to form a flat looking surface. Externally the plate type evaporator looks like a single plate but inside it, there are several turns of the metal tubing through which the refrigerant flows.

The advantage of a plate type evaporator is that they are more rigid as the external plate provides lots of safety. The external plate also helps in increasing heat transfer from the metal tubing to the substance to be chilled. These types of evaporators are easy to clean and can be manufactured cheaply. They can be converted into box shape, partitions or shelves as required for different purposes. Due to various advantages and flexibility offered by a plate type evaporator, they are used extensively.

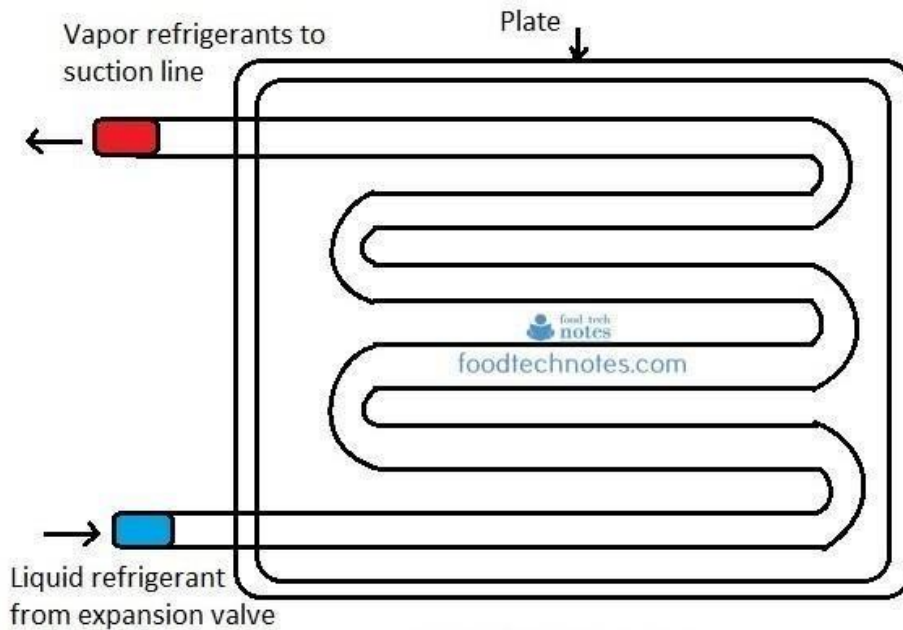

Figure 5.6: Plate Evaporator

Finned tube evaporator:

The finned evaporators are tube type evaporators covered with the fins. When the fluid (air or water) to be chilled flows over the bare tube evaporator, lots of cooling effect from the refrigerant goes wasted since there is less surface for transfer of heat from fluid to refrigerant. The fins on the finned tube evaporator increases contact surface area and increases heat transfer rate. Thus finned evaporators are more effective than bare tube evaporators.

For fins to be effective, it is very important that there is good contact between coil and the fins. In some cases fins are soldered directly to surface of the coil and in other cases, the fins are just slipped over the surface of tubes or coils. The finned evaporators are most commonly used in the air conditioners of almost all type like window, split, packaged and central air conditioning. In this system, finned evaporator is known as cooling coil.

The hot air flows over finned evaporator for cooling. To increase effectiveness of heat transfer from evaporator, the tubing are also given internal fins. These fins are made by forming different internal cross section shapes at the time of manufacturing of tubing.

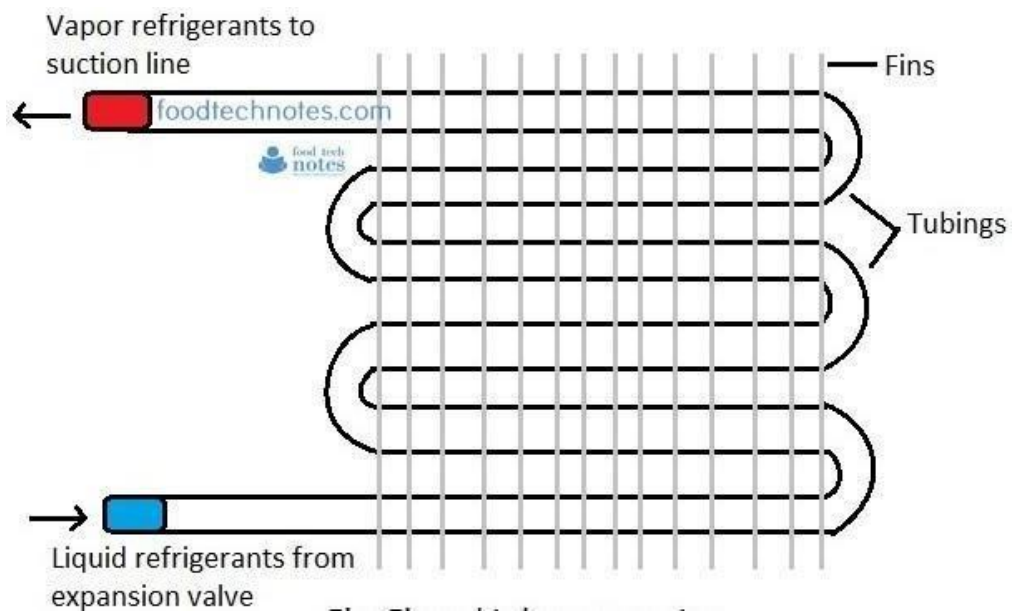

Figure 5.7: Finned Tube Evaporator

5.3 Pump Motor

Introduction

This is a low cost, small size Submersible Pump Motor which can be operated from a 2.5 ~ 6V power supply. It can take up to 120 liters per hour with very low current consumption of 220mA. Just connect tube pipe to the motor outlet, submerge it in water and power it. Make sure that the water level is always higher than the motor. Dry run may damage the motor due to heating and it will also produce noise.



Figure 5.8: Pump Motor

Feature:

- Operating Current : 130 ~ 220mA
- Flow Rate : 80 ~ 120 L/H
- Maximum Lift : 40 ~ 110 mm
- Continuous Working Life : 500 hours
- Driving Mode : DC, Magnetic Driving
- Material : Engineering Plastic
- Outlet Outside Diameter : 7.5 mm
- Outlet Inside Diameter : 5 mm

5.4 Cooling Fan

A fan is a powered machine used to create a flow of air. A fan consists of a rotating arrangement of vanes or blades, which act on the air. The rotating assembly of blades and hub is known as an impeller, rotor, or runner. Usually, it is contained within some form of housing, or case.



Figure 5.9: Cooling Fan

Feature

- Operation Humidity - 0%~95%
- Insulation Grade - According to IEC61858 Grade F
- Voltage V - 220/230
- Frequency Hz - 50/60
- Current - 0.12/0.10
- Power(W) - 19/14
- Speed(R/Min) - 2500/2700

5.5 Complete Project Prototype Image :

Our Project power supply in a SMPS. Here we need 5V DC to operate this project. That's why we use 5V 7Amp rating Switch Mode Power Supply . We input 220V AC and SMPS convert it 5V DC and entire in our Circuit. This evaporator pad mad by PVC board. Its a demo project that's why we made it with PVC board. Its a 14 inches frame. We use here 4 layer net inside evaporator pad. Water goes down through the net and the same time an exhaust fan will blow the cool air . This the main purpose of our system.



Figure 5.10: Evaporator Pad

This is our evaporator water storage. Pump take water from water tank and store it in this tank. Water will goes down (Tank) through evaporator net. That's the water cycle of our system.

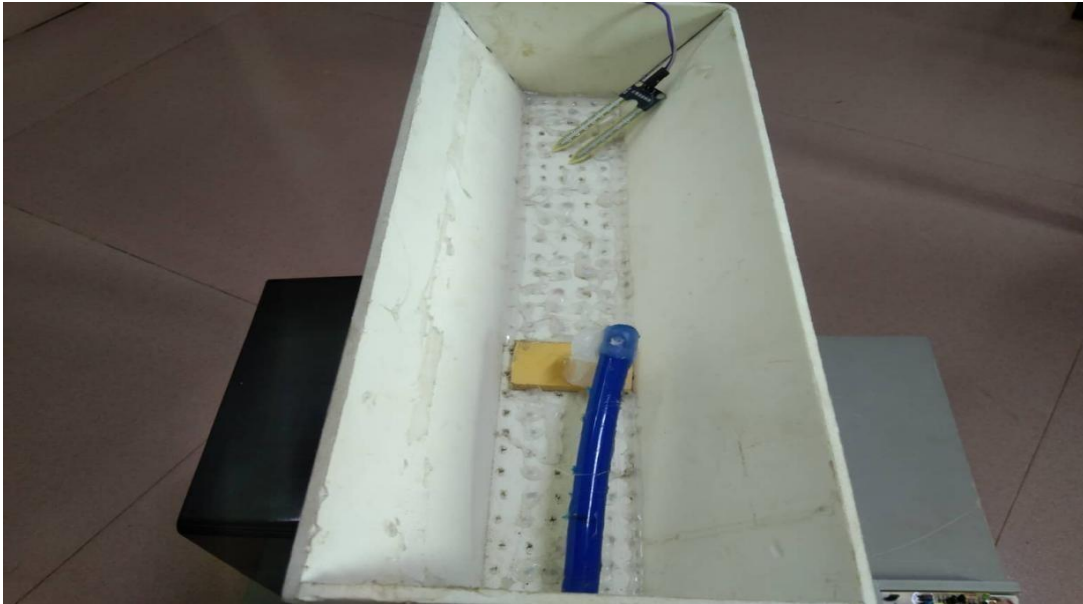

Figure 5.11: Evaporator Water Storage



Figure 5.12: Exhaust Fan

SMPS is one of the most important instrument used here. Here the input of SMPS is 220 volts AC and output is 5V DC. Then here connect with the relay and Soil moisture Sensor (DC Components). Exhaust fan is connected to direct 220V AC current which is control with a switch.



Figure 5.13: Project Prototype Image (Front View)

CHAPTER 6

EXPERIMENTAL RESULT

6.1 Result

We have been able to build our system by following all the objects and methodologies. At first we have set up the all components well for our system. When the system is first turned on, current will flow in the system by converting DC voltage from 220 volts AC for SMPS. Then pump motor will be start as a result, water will continue to circulate from the water reserve tank to the water distribution road through the water evaporator. In this way, when the evaporator is cold, the water inside it also cools and forms steam in the water. Now when the fan is turned on, when air is blown from one end, cold air is available from the other side. The efficiency of this project is very good. It is capable of working for a long time. We are satisfied its performance.

CHAPTER 7

DISCUSSION

7.1 Discussion

The evaporator cooling system works effectively and makes cooling process easy, more precise and reliable and is more advantageous than the conventional methods reducing manual efforts, errors and being much efficient. The proposed prototype allows achieving an economical and a low-cost cooling system. When we made this project then we face some of problem. We did not run it smoothly. After hard work and team work, we did it.

7.2 Advantage

- We usually lower temperature water than the room temperature, so that we can lower the room temperature easily which will not harm our environment.
- In our country, the cooling systems that we usually use it keep the room temperature low, but the humidity outside increases the temperature, which causes a lot of damage to our environment. And with this system maybe the temperature of the room cannot be lowered to -18 degrees or eighteen but our system will have a certain temperature so that there is no damage to our environment or the balance of the environment is all suitable.
- Creates a comfortable and productive work environment.
- Good Indoor Air Quality.
- Energy-efficient ventilation and cooling solution.
- Environmentally friendly.
- Investment in this sustainable technique is often subsidized.
- No Oil consumption.
- Less skill technicians is sufficient to operate.
- Installation is simplified very much.
- Simple construction
- Ease of operation.

7.3 Application

The project has a major application in the

- It can be used for Industrial work.
- It can be used in factories.
- It can be used for indoor purpose.

7.4 Limitation

It is a demo project so we found some limitation. In future we will work for reduce this kind of limitation. These limitations are –

- It is a demo project so its accuracy is 85%.
- Project has no extra power supply.

CHAPTER 8

CONCLUSION

8.1 Conclusion:

As using the water for the evaporation purpose, which leads to decrease the temperature of the air also containing the most economically environmental effective system. In this project paper of evaporating cooling technology, methods are studied for the commercial and comfort purposes. Indirect evaporative coolers have shown higher values of effectiveness and more economically operated in the terms of energy consumption saving, particularly the M-Cycle. However, the combined system of direct and indirect cooling system has similar performance or even the higher but their system consists of higher initial cost and the major problems like noise & vibrations, pressure loss and friction loss. But our system gives the better output better than previous and save the costing.

8.2 Future Scope

The model can be improved by making some changes in the hardware and components. Some suggestions are given below-

- We will increase its working accuracy level.
- We will increase its cooling system.
- We will add a sensor and a display to measure and monitoring the cooling situation.

Reference

- [1] S.S. Wane and M.B. Nagadeve, Dr. Punjabrao Deshmukh Krushi Vidhyapeeth, Akola Maharashtra. JOURNAL OF ENVIRONMENTAL RESEARCH AND DEVELOPMENT “Design of Air Cooling System for College Auditorium”, Published March 2013.

- [2] Md. Almost Asim Mahmud, Dr. Md. Alamgir Hossain, M.A.Muktadir INTERNATIONAL JOURNAL OF EMERGING TECHNOLOGY AND ADVANCED ENGINEERING “Design Optimization and Installation of the Evaporative Cooler.”, Volume 5, Issue 5, October-2015 .

- [3] Dave janquart ; DESIGN OF AN AIR DISTRIBUTION SYSTEM FOR A MULTI-STORY OFFICE BUILDING. International Journal of Advance Technology in Engineering And Science , Vol. 2 , Issue no. 8, November 2018.

- [4] O. Amer, R. Boukhanouf, and H. G. Ibrahim A Review of Evaporative Cooling Technologies International Journal of Environmental Science and Development, Vol. 6, No. 2, February 2015.

- [5] Shashank Shekhar, Santosh Suman, Dr. H.S. Moharana, D. Sethy Performance of Different Pad Materials in Advanced Desert Coolers- A Comparative Study Volume 6 Issue No. 4.

- [6] Avinash Pandey, Dr. P.K .Jhinge Indirect Evaporative Cooling Applications IJSRD - International Journal for Scientific Research & Development| Vol. 3, Issue 03, 2015 .

- [7] Rajesh Maurya, Dr. Nitin Shrivastav, Vipin Shrivastava Performance and Analysis of an Evaporative cooling System International Journal of Scientific & Engineering Research, Volume 5, Issue 10, October-2014 .

- [8] Manoj Kumar Mehra , Vikas Bansal, Ravindra Singh jhala a review on multi-stage evaporative cooler , International Journal of Advance Technology in Engineering And Science , Vol. 4 , Issue no. 11 November 2016.
- [9] V. Vakiloroyaya, B. Samali, A. Fakhar, and K. Pishghadam, “A review of different strategies for HVAC energy saving,” *Energy Conversion and Management*, vol. 77, pp. 738-754, 2014.
- [10] F. Fardeheb, “Examination and review of passive solar cooling strategies in middle eastern and north african vernacular architecture,” in *Proc. ISES World Congress 2007 (Vol. I – Vol. V)*, Florida, 2009, pp. 2511-2515.
- [11] D. Sekulic and R. Shah, *Fundamentals of heat Exchanger Design*, 1st ed. New York, U.S.A.: Wiley, 2002, pp. 15-45.
- [12] M.-H Kim, J. Kim, O. Kwon, A. Choi, and J.-W. Jeong, “Energy conservation potential of an indirect and direct evaporative cooling assisted 100% outdoor air system,” *Building Services Engineering Research and Technology*, vol. 32, pp. 345-360, 2011.