



UGC & Govt. Approved  
**Sonargaon University (SU)**  
সোনারগাঁও ইউনিভার্সিটি (এসইউ)

## **Car Suspension System Using Bevel Gears**

A Thesis

By

Md. Shihab Uddin	ID: BME-1902018139
Md. Rashadul Islam Rony	ID: BME-1802015309
S.M Abbas Hossain Manik	ID: BME-1902018009
Md. Asaduzzaman Asad	ID: BME-1902018016
Md. Masum Rez	ID: BME-1902018140
Md. Mizanur Rahman	ID: BME-1901017599

**Supervisor**

**Niloy Sarkar**

Lecturer

Department of Mechanical Engineering

Sonargaon University (SU)

Dhaka-1215, Bangladesh

# Car Suspension System Using Bevel Gears

Submitted by

Student Name	Student ID	Signature
Md. Shihab Uddin	ID: BME-1902018139	.....
Md. Rashadul Islam Rony	ID: BME1802015309	.....
S.M Abbas Hossain Manik	ID: BME-1902018009	.....
Md. Asaduzzaman Asad	ID: BME-1902018016	.....
Md. Masum Reza	ID: BME-1902018140	.....
Md. Mizanur Rahman	ID: BME-1901017599	.....



Niloy Sarkar

Lecturer

SUBMITTED TO THE:

DEPARTMENT OF MECHANICAL ENGINEERING

SONARGAON UNIVERSITY (SU)

In partial fulfillment of the requirement for award of the degree

Of

Bachelor of Science in Mechanical Engineering

January, 2023

## LETTER OF TRANSMITTAL

January, 2023

To

**Niloy Sarkar**

Lecturer

Department of Mechanical Engineering.

Sonargaon University

Subject: Submission of Project Report.

Dear Sir,

We are pleased to submit the project report on “**Car Suspension System Using Bevel Gears**”. It was a great pleasure to work on such an important topic. This project has been done as per instruction of your supervision and according to the requirements of the Sonargaon University.

We expect that the project will be accepted by the concerned authority we will remain happy to further explanation that you may feel necessary in this regard.

Thank You

Sincerely yours,

S M Abbas Hossain Manik

BME-1902018009

Md. Asaduzzaman Asad

BME-1902018016

Md. Shihab Uddin

BME-1902018139

Md. Masum Reza

BME-1902018140

Md. Rashadul Islam Rony

BME-1802015309

Md. Mizaur Rahman

BME-1901017599

## **BOARD OF EXAMINERS**

The thesis titled “**Car Suspension System Using Bevel Gears**” submitted by S M Abbas Hossain Manik BME-1902018009, Md. Shihab Uddin BME-1902018139, Md. Rashadul Islam Rony BME-1802015309, Md. Asaduzzaman Asad BME-1902018016, Md. Masum Reza BME-1902018140, Md. Mizaur Rahman BME-1901017599, has been accepted as satisfactory in partial fulfillment of the requirement for the degree of Bachelor of Science in Mechanical Engineering on 24-01-2023.

.....

1. Niloy Sarkar

Lecturer

Sonargaon University

.....

2.Internal/External Member

.....

3.Internal/External Member

## DECLARATION

We do hereby solemnly declare that, the work presented here in this project report has been carried out by us and has not been previously submitted to any University/ Organization for award of any degree or certificate

We hereby ensure that the works that has been prevented here does not breach any existing copyright.

We further undertake to indemnify the university against any loss or damage arising from breach of the foregoing obligation.

STUDENT NAME	STUDENT ID	SIGNATUR
S M Abbas Hossain Manik	BME-1902018009	
Md. Shihab Uddin	BME-1902018139	
Md. Asaduzzaman Asad	BME-1902018016	
Md. Masum Reza	BME-1902018140	
Md. Rashadul Islam Rony	BME-1802015309	
Md. Mizanur Rahman	BME-1901017599	

**DEDICATED  
TO  
“OUR BELOVED PARENTS”**

# ACKNOWLEDGEMENT

First, we started in the name of Almighty Allah. This thesis is accomplished under the supervision of **Niloy Sarkar, Lecturer**, Department of Mechanical, **Sonargaon University**. It is a great pleasure to acknowledge our profound gratitude and respect to our supervisor for this consistent guidance, encouragement, helpful suggestion, constructive criticism and endless patience through the progress of this work. The successful completion of this thesis would not have been possible without his persistent motivation and continuous guidance.

The authors are also grateful to **Md. Mostofa Hossain, Head** of the Department of Mechanical Engineering and all respect teachers of the Mechanical Engineering Department for their co-operation and significant help for completing the thesis work successfully.

We sincerely would like to thank all instructions and staffs of the Mechanical Engineering of Sonargaon University (SU), Dhaka which contributed in various ways to the completion of this thesis.

Finally, we would like to express our deepest gratitude to our entire group member whose support and manual labor contributed in various ways for the completion of this thesis work .

Authors

Sonargaon University (SU)

# ABSTARCT

Our Project, The Car Suspension System Combines a differential mechanism and an oscillating system. A differential is a gear train with three drive shafts that has a property such that the rotational speed of one shaft is the average speeds of the others, or a fixed multiple of that average and Oscillation is the repetitive or periodic variation of an object. The Frame of the system is mostly made of Mild steel. The frame that holds the tires oscillates freely. The same frame is connected to the differential. A motor is connected to a gear in the differential mechanism, thereby making it the driving gear. The driving gear is connected by bevel gear on both the side. Each gear is connected to two wheels on each side. Each wheel is driven by an individual motor. The motor makes sure that the gears and the wheels are in motion and the oscillating property makes sure that the vehicle is moving forward even in rough terrain. This system is control by mobile phone through IoT.



## TABLE OF CONTENTS

Letter of Transmittal	ii
Board of Examiners	iii
Declaration	iv
Dedicated	v
Acknowledgement	vi
Abstract	vii
Table of Contents	viii

### CHAPTER-1

#### INTRODUCTION

1.1 Introduction	01
1.2 Objectives	03
1.3 Scope of Use	03
1.4 Internet of Things (IoT) Basic Concept	03
1.5 IoT Characteristics	04
1.6 Structure of the Projects	05

### CHAPTER 2

#### ABOUT BEVEL GEAR

2.1 Introduction	07
2.2 A Brief History	07
2.3 What Is Bevel Gear	07
2.4 A Bevel Gear is Beveled	08
2.5 Types of Bevel Gear	09
2.6 Pros and Cons of The Bevel Gear	10
2.7 Details of the topic	10
2.8 Summary	14

## CHAPTER-3

### HARDWARE AND SOFTWARE ANALYSIS

3.1 Introduction	15
3.2 Node MCU	15
3.3 Motor Driver IC	18
3.4 DC Gear Motor	21
3.5 Battery	23
3.6 Arduino Software	24
3.7 Proteus Software	26
3.8 Blynk IoT App	27

## CHAPTER-4

### METHODOLOGY

4.1 Methodology	30
4.2 Block Diagram	30
4.3 Circuit Diagram	31
4.4 Working Principle	31
4.5 Our Final Project View	31

## CHAPTER-5

### BENEFITS OF BEVEL GEAR

5.1 Advantages	32
5.2 Disadvantages	32
5.3 Why we used bevel gear	32
5.4 How are bevel gear different other	33
5.5 Why bevel gear is better than spring	33
5.6 Other place where bevel gear used	33

## CHAPTER-6

### RESULT AND DISCUSSION

6.1 Weight Stability	34
6.2 Front Wheel (Left Side)	35
6.3 Front Wheel (Right Side)	35
6.4 Back Wheel (Left Side)	36
6.5 Back Wheel (Right Side)	36
6.6 Front Wheel (Both Side)	37
6.7 Back Wheel (Both Side)	37
6.8 Result	38
6.9 Discussion	38
6.10 Application	38

## CHAPTER-7

### CONCLUSION

7.1 Conclusion	39
7.2 Future Scope	39

Reference	40
-----------	----

## LIST OF FIGURES

Figure no	Figure name	Page no
1.1	IoT Basic Structure	04
1.2	IoT Characteristics	05
2.1	Straight bevel gear	08
2.2	Spiral bevel gear	08
2.3	Zerol bevel gear	09
2.4	Straight bevel gear	12
2.5	Zerol Bevel Gear	12
2.6	Spiral Bevel Gear	13
2.7	Hypoid Gear	14
3.1	Node MCU	16
3.2	Node MCU Schematic Diagram	16
3.3	Node MCU Pin Out	17
3.4	Motor driver IC L293D	18
3.5	L293D circuit Diagram	20
3.6	Gear Motor	22
3.7	3.7V Battery	23
3.8	Arduino Software Interface IDE	25
3.9	Proteus Software Interface	27
3.10	Blynk App Interface	28
4.1	Block Diagram	30
4.2	Circuit Design	31
4.3	Our Project Prototype	31

# CHAPTER 1

## INTRODUCTION

### 1.1 Introduction

Gear has emerged as the most important component in modern manufacturing for conveying motion and power because of its precise transmission and ease of control, the. Function generators, robotics, planetary reducers, and gear pumps are examples of common gear applications. The gear meshing concept has been applied to the development of a plethora of different types of gears, including the involute gear, the cycloid gear, the spiral bevel gear, and the hypoid gear, among others. [1] Hypoid bevel gears are widely used in the power transmission business and are found in a variety of applications such as autos, helicopters, and ships. They are generally recognized as an important component of power transmission in mechanical engineering and mechanical science. When working at high speeds and under extreme loads, the machining accuracy and surface quality of a hypoid gear are crucial for transmission precision, noise, and dynamic performance, among other things. [2]

Since it distributes motion and power between two intersecting shafts and is fundamental to the equipment's longevity, the bevel gear is an essential component of mechanical transmission systems. [3] In turbo shaft aircraft engines, the central-driven bevel gear (CDBG) is a vital component of the power transmission system that ensures smooth operation of the engine. It is necessary for the gear transmission system to work at a high rate in order for it to be functional; as a result of complicated excitation sources operating at speeds lower than the operational speed, a variety of modal vibrations arise in the structural system. This issue may become more obvious in the future since future aircraft engines will be more compact and heavily loaded than those currently in use. A high rate of wear on the transmission is nearly inevitable, and accidents affecting the transmission or potentially the engine are a possibility [4].

The compound gear shaft, which is comprised of a bevel gear and a spline, is a fundamental mechanical component for the transmission of power and motion in mechanical systems. They are typically found in mechanical transmission systems, such as those seen in automobiles and aircraft. Inaccurate coaxiality is a common sort of shaft

component defect, and the significance of this error is commonly reflected in the design of mechanical transmission systems. It is possible that the vibration and noise caused by a compound gear shaft with a large coaxiality error will damage the mechanical transmission device, resulting in a significant reduction in its service life. The determination of coaxiality of components in a timely and accurate manner has become crucial for mechanical transmission systems as a result [5].

Rough machining, such as tooth flank milling and heat deformation, is performed as the first three phases in the manufacturing process for aerospace spiral bevel gears, and is followed by finishing, such as tooth flank grinding. When it comes to achieving high geometric precision in the tooth flank, it's always been important to change machine tool settings on the fly. This modification technique is thought to represent a data-driven adaptive process in which the current model flank is infinitely close to the intended flank while still meeting the geometric restrictions of the manufacturing process. In spite of the fact that accurate prediction and optimization are necessary for the development of high tooth flank geometric precision, the critical heat treatment process has been constructed in a random manner. Also possible is that the heat treatment approach will have a significant impact on the accuracy with which the tooth flanks are machined during the actual gear manufacturing process [6].

The spiral bevel gear is a form of gear that is commonly used in mechanical equipment, such as robotics, automation equipment and aeronautical vehicles. Typically, Gleason Work's face-milling technology is used to create this gear part, which is then put into a specialized free-form gear cutting machine for precision cutting. Grain meshing theory states that a gear surface is generated by taking into account how the cutter and gear move relative to one another in their respective envelope kinematics. The gear face-milling operation, despite the fact that it has traits in common with other milling methods and gear generating behaviours, stands out as a one-of-a-kind activity. The discovery of mechanics and the improvement of cutting performance have been the subject of numerous recent efforts, which have been directed specifically at machining processes in particular. Chip form mechanics, cutting force prediction, and even cutting dynamics have all been investigated in these research [7].

The primary gear box of a helicopter can be made much lighter by incorporating face-gear drives into the design. A number of advantages over spiral bevel gears are also available,

including the absence of axial stress on the spur pinion, a high gear ratio, and the ability to accommodate a wider range of shaft angle variations. In spite of this, accurate machining in this manner becomes extremely challenging because of the complicated tooth surface structure. Many hours have been spent researching the development of face-gear drives for use in power transmission applications. Face gears are frequently machined or ground, and simulations of the cylindrical gear meshing with the face gear are frequently used in this process. This is especially true in the case of large face gears. [8]

## **1.2 Objectives**

The objectives of this project are:

- To study about **Car Suspension System Using Bevel Gears**.
- To implement a Spring-less Car Suspension.
- To implement bevel gear.
- To control the vehicle with IoT.
- To test the performance of the system.

## **1.3 Scopes of use**

- In reduce oil wastage.
- Move Smoothly in any rough road..

## **1.4 Internet of Things (IoT) Basic Concept**

The inter communication between device to device or machine learning connected through the internet with embedded technology systems using wireless sensors, actuators which is remotely controlled, monitor and optimized by the user for automation is referred as Internet of things (IoT). Here the term “Things” means physical devices such as chips, cameras, sensors and other such devices. These physical devices are responsible to communicate, collect information and exchange data by connecting a network. The embedded technology of these physical devices makes this exchange of information each other possible. There are an assortment of home robotization includes that can help making life at home increasingly advantageous and simpler to oversee, particularly for

occupied, huge families. Suppose you could consequently manage and control the gadgets that you ordinarily turn on and off each day. With a home computerization framework, you can manage appliances when you're out of the house and wondering if you remembered to turn off light or not, smart system will be there to answer the question. The developing nearness of the Internet of Things in individual's lives has made development and advancement in the savvy home space, enabling clients to associate their gadgets through the web to their phones and tablets, and make better than ever benefits for family units.

In addition, as house owner are adjusting their gadgets to one focal application, gadget or center, they further understand the worth these home robotization items can bring to a family. It is the connectivity apart from the conventional devices using internet such as desktop, laptops, Smartphone, tablets etc.

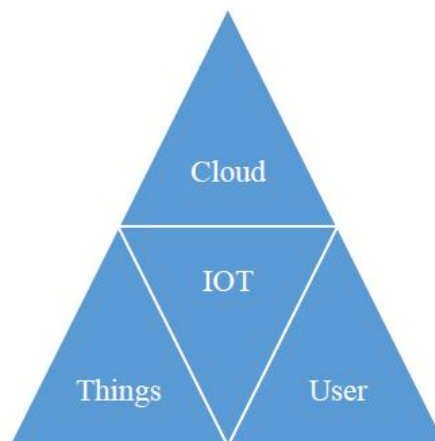

Figure 1.1: IoT Basic Concept

## 1.5 IoT Characteristics

IoT is one of the most popular terms in this modern era of the world. Internet of things (IoT) explains the network of different devices like home appliances or office works that contains software, electronics, sensor and connectivity to allow them to exchange data with connections. Several sensors and actuators are used to connect those devices and give feedback to them according self-operations. IoT has convinced the world with its worldwide features and human beings are fully dependable on it. In the near future, this IoT will make an unimaginable impact on the daily life of human beings which will make



the life of human easier, smarter and safe. At present, it has already grabbed the promising and large digital fields of modernization which is rapidly increasing.

The characteristic of IoT includes the synthesis of hardware and software abiding by complex algorithm and computation technique which intelligence authorizes them to behave and act accordingly to the situations. The connectivity of IoT devices allows connecting various objects by creating network and comprehensive intelligence system. The dynamic nature of IoT devices tells the state of device whether it is on or off. An IoT device also collects dynamic change of data information from its neighboring environment. The essence of IoT is diversity and heterogeneity because of using distinct platform and network. Finally, security issues of IoT are being very important because of its delicate information and enormous action being taken to prevent security problems. In future IoT components enormity will increase in such level so that it becomes very difficult to deal or manage it.

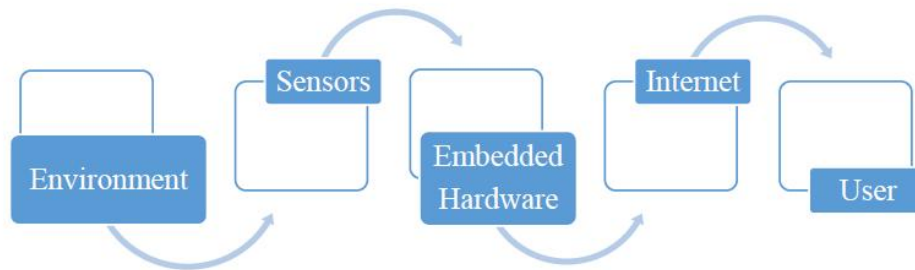

Figure 1.2: IoT Characteristics

## 1.6 Structure of the Project

This Project is organized as follows:

**Chapter 1: Introduction:** The first chapter contains the statement of the introduction, our background study for the project, problem statement, objectives of the study and the project outline.

**Chapter 2: Literature Review:** The chapter two contains our introduction, literature review part.

**Chapter 3: Hardware and Software Analysis:** Chapter three describes the theoretical model. Here we mainly discuss about proposed system Hardware and software development of our project etc.

**Chapter 3: Methodology:** Chapter three describes the theoretical model. Here we mainly discuss about proposed system architecture in details with having block diagram, circuit diagram, structural diagram, project working principle, complete project image etc.

**Chapter 4: Result and Discussion:** Chapter four deals with the result and discussion and discuss about our project advantages and application.

**Chapter 5: Conclusion:** Chapter five all about our project conclusion and future scope.

## CHAPTER 2 ABOUT BEVEL GEAR

### 2.1 Introduction

This chapter is arranged on details of bevel gear. By reading them, we can overcome the mistakes of the previous project and make a more effective project.

### 2.2 A Brief History

Gears were used by mankind since early **400 B.C.** They were first used by the **Chinese** to carry out tasks related to transferring power through rotations, similar to their purpose in the modern times. One of the first applications was the **Chinese South-Pointing Chariot** – a vehicle built on two wheels which bore a movable indicator that always pointed South no matter how the chariot turned, without the use of magnets. The essence is old, but technology has changed and evolved gears a lot. The 18th century **industrial revolution** was the cause of this breakthrough. Alongside many new designs such as the **involute curve**, the bevel gear was born.

### 2.3 What is a Bevel gear?

**Bevel gears** are useful when the direction of a shaft's rotation needs to be changed. They are usually mounted on shafts that are 90 degrees apart, but can be designed to work at other angles as well. The picture on the right shows how bevel gears are used to change direction. They change the transmission of the power or torque from one plane to another, which is different from conventional gears that transfer rotations within a single two dimensional plane.

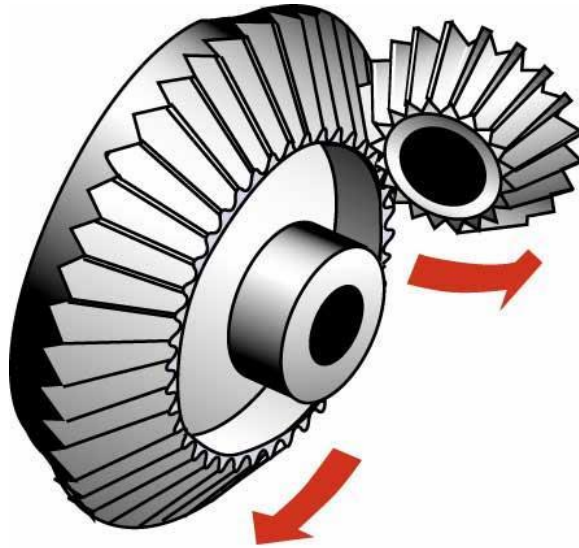

Figure 2.1: Straight bevel gear

#### 2.4 A Bevel gear is ‘Beveled’

As the term “bevel” would suggest, the face of a bevel gear is angled. Typically, a bevel gear is **conical** in shape, with the teeth running along the side of the cone, and the angle of the sides can be varied, depending on the application for the gear.

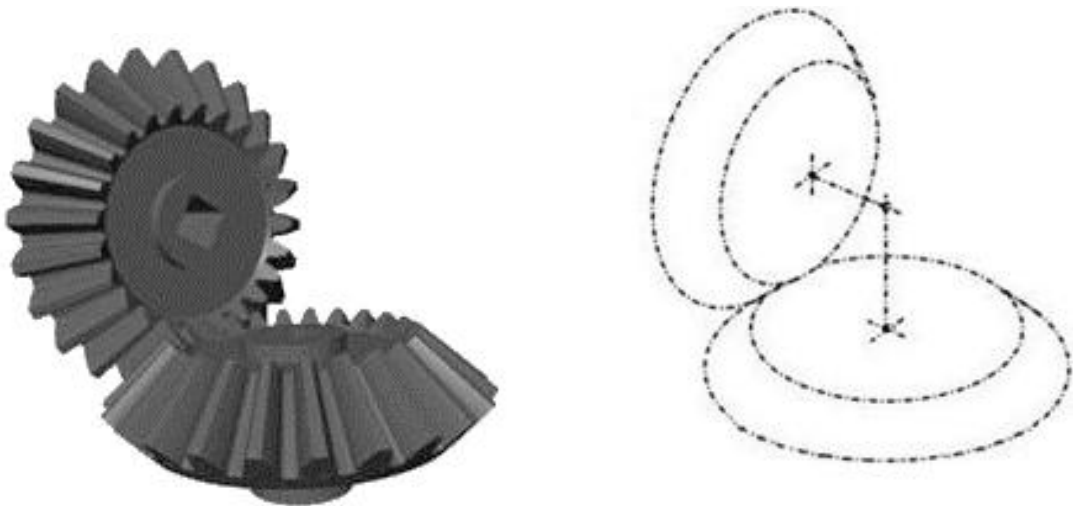

Figure 2.2: Spiral bevel gear

## 2.5 Types of Bevel Gears

There are 4 commonly known types of bevel gears: Straight bevel gear, Zerol bevel gear, Spiral bevel gear, and lastly the Hypoid bevel gear. These will be discussed in detail later on.



**Straight bevel gear**

**Zerol bevel gear**

**Spiral bevel gear**

**Hypoid bevel gear**

Another type of bevel gear is the Miter gear. Miter gears are a type of bevel gears that have **equal numbers of teeth**. Miter gears are useful for transmitting rotational motion at a **90 degree** angle with a **1:1 ratio**. Geometrically, a miter bevel gear's teeth can be straight, zerol, or even spiral in shape.



Figure 2.3: Zerol bevel gear

## 2.6 Pros and Cons of the Bevel Gear

### Advantages:

The main advantage of Bevel gears is that the gears make it possible to change the **operating angle**. Through this, aside from transmitting direction alone, you can increase or decrease the torque, force and speed being transmitted by changing or **Tweaking the ratio of the teeth**. Secondly, they can be made out of a variety of different materials. **Metal** ones are common in clocks as well as in hand tools such as the handheld drill drivers. However, they can also be made out of **plastic** or **nylon**, and they are more common in electronic machines like toys as well as other components. Gears made with non-metallic materials give noiseless operation at higher speeds.

### Disadvantages:

One disadvantage of the Bevel gear is that one wheel of such gear can only work with its **complementary wheel**, and no other. Another downside is that bevel gears need extreme **precision in mounting**. Lastly, the shaft bearings need to be made to support relatively heavier loads or forces

## 2.7 Details Of The Topic

### Four Types of Bevel gear According to Tooth Race

**1. Straight Bevel Gear** – a bevel gear whose **teeth are straight** but their sides are tapered so that they would intersect the axis at a common point (pitch cone apex) if extended inward.

**Features:** Easy to manufacture, and provides high reduction ratios: up to 1:5

**Applications:** Machine tools, printing presses, differential units.

### Straight Bevel Gear Specifications

<b>Number</b>	<b>Items</b>	<b>Values</b>
1	No Of Teeth	20T
2	Module	0.5
3	Material	Plastic
4	Height	8 mm
5	Appox. Outer Dia	11 mm – 0.44 Inch
6	Appox. Inner Dia	3 mm – 0.12 Inch



Figure 2.4: Straight bevel gear

**2. Zerol Bevel Gear** – a bevel gear whose teeth is **curved** but lie in the same direction as the teeth of straight bevel gears. Spiral angle is zero.

**Features:** These gears normally have a pressure angle of **20 deg**. The minimum number of teeth on the pinion is **14**. The design of Zerol gears is relatively specialized and they are manufactured using special "Gleason" machine tools..

**Applications:** Essentially used in applications similar to spiral or straight bevel gear, but with **higher accuracy and speed**.



Figure 2.5: Zerol Bevel Gear



**3. Spiral Bevel Gear** – a bevel gear having **curved oblique teeth** on which contact begins gradually and continues smoothly from end to end.

**Features:** High strength and durability, reduced gear noise, but involves difficulties in manufacturing.

**Applications:** Vehicles, final reduction gearing for ships, suitable for high speed and heavy load drives.



Figure 2.6: **Spiral Bevel Gear**

**4. Hypoid Gear** – is similar to spiral bevel gears; except that the shaft axes are **offset, nonintersecting**.

**Features:** The minimum number of teeth for speed ratios greater than 6:1 is eight although 6 teeth pinions can be used for ratios below 6:1. Hypoid gears have pressure angles between **19 and 22 deg**.

**Applications:** Automotive applications, applications that require **smooth and quiet operation**.



Figure 2.7: Hypoid Gear

## 2.8 Summary

The above has been discussed in detail in the bevel gear details which has given us a lot of motivation to do this project.

## CHAPTER 3

### HARDWARE AND SOFTWARE ANALYSIS

#### 3.1 Introduction

In this section, we will discuss elaborately about our hardware design of “**Car Suspension System Using Bevel Gears**” and the component description, features, working procedure and description of our all equipment.

#### Software

- Proteus 8.9
- Blynk App

#### Hardware

- Node MCU
- Motor Driver
- Bevel Gear
- Battery
- Motor
- Wheel

#### 3.2 Node MCU

Node MCU is an open-source firmware for which open-source prototyping board designs are available. The name "Node MCU" combines "node" and "MCU" (micro-controller unit). The term "Node MCU" strictly speaking refers to the firmware rather than the associated development kits. Both the firmware and prototyping board designs are open source. The firmware uses the Lua scripting language. The firmware is based on the eLua project, and built on the Espressif Non-OS SDK for ESP8266. It uses many open source projects, such as lua-cjson and SPIFFS. Due to resource constraints, users need to select the modules relevant for their project and build a firmware tailored to their needs. Support for the 32-bit ESP32 has also been implemented.

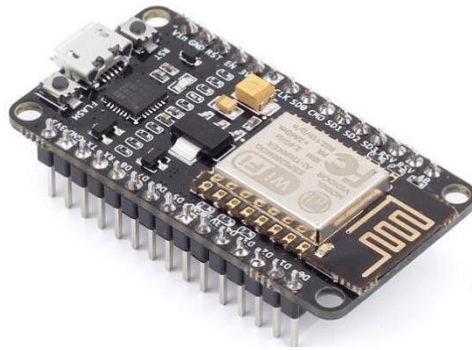

Figure 3.1: Node MCU

The prototyping hardware typically used is a circuit board functioning as a dual in-line package (DIP) which integrates a USB controller with a smaller surface-mounted board containing the MCU and antenna. The choice of the DIP format allows for easy prototyping on breadboards. The design was initially based on the ESP-12 module of the ESP8266, which is a Wi-Fi SoC integrated with a Tensilica Xtensa LX106 core, widely used in IoT applications.

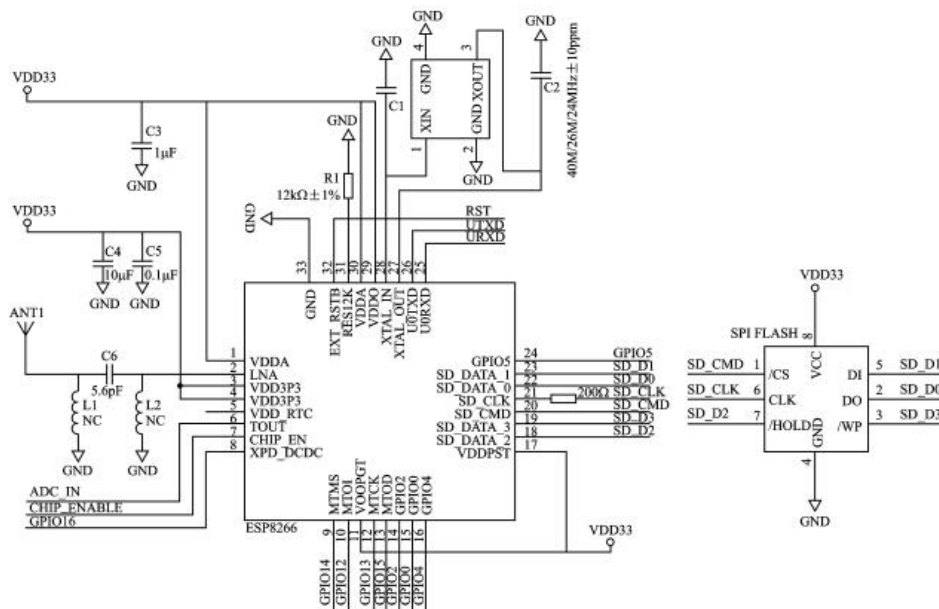

Figure 3.2 Node MCU Schematic Diagram

This is an open source IoT platform. It includes firmware which runs on the ESP8266 Wi-Fi SoC from Express Systems, and hardware which is based on the ESP-12 module. The

term "Node MCU" by default refers to the firmware rather than the development kits. The firmware uses the Luascripting language. It is based on the eLua project, and built on the Espressif Non-OS SDK for ESP8266. Node MCU was created shortly after the ESP8266 came out. On December 30, 2013, Espressif Systems began production of the ESP8266. The ESP8266 is a Wi-Fi SoC integrated with a Tensilica Xtensa LX106 core, widely used in IoT applications (see related projects). Node MCU started on 13 Oct 2014, when Hong committed the first file of nodemcu-firmware to GitHub. Two months later, the project expanded to include an open-hardware platform when developer Huang R committed the gerber file of an ESP8266 board, named devkit v0.9. Later that month, Tuan PM ported MQTT client library from Contiki to the ESP8266 SoC platform, and committed to NodeMCU project, then Node MCU was able to support the MQTT IoT protocol, using Lua to access the MQTT broker. Another important update was made on 30 Jan 2015, when Devsaurus ported the u8glibto Node MCU project,<sup>[15]</sup> enabling NodeMCU to easily drive LCD, Screen, OLED, even VGA displays. In summer 2015 the creators abandoned the firmware project and a group of independent contributors took over. By summer 2016 the NodeMCU included more than 40 different modules. Due to resource constraints users need to select the modules relevant for their project and build a firmware tailored to their needs.

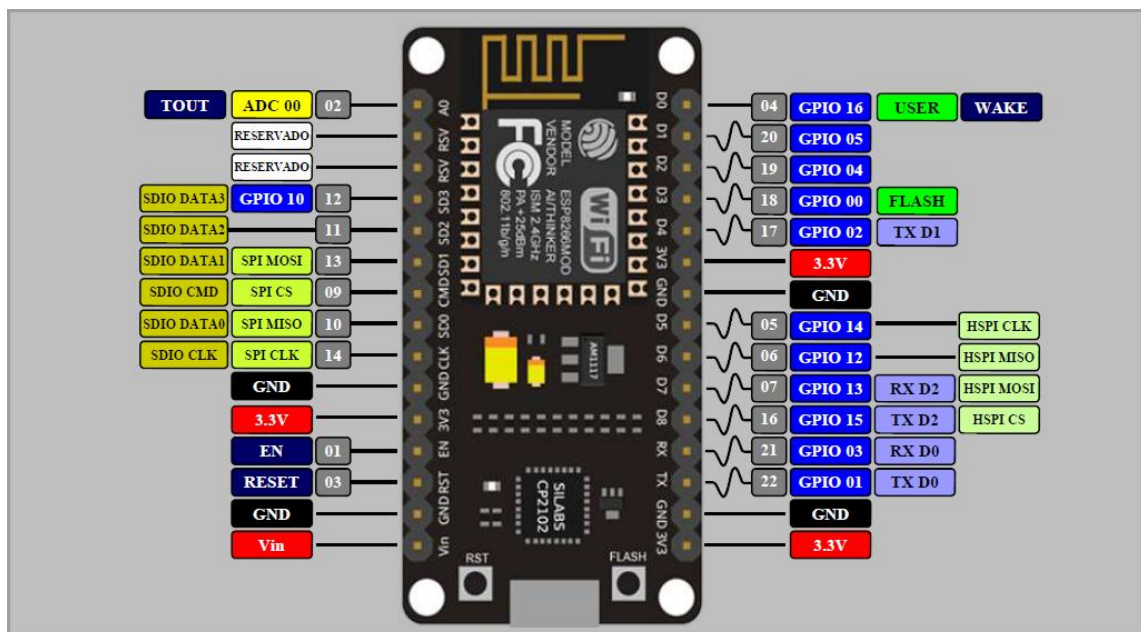

Figure 3.3: Node MCU Pin Out

Node MCU V3 ESP8266 ESP-12E is Wi-Fi development board that helps you to prototype your IoT product with few Lua script lines, or through Arduino IDE. The board

is based on ESP8266 ESP-12E variant, unlike other ESP-12E, you won't need to buy a separate breakout board, USB to serial adapter, or even solder it to a PCB to get started, you will only need a USB cable (Micro USB).

## Features

1. Communication interface voltage: 3.3V.
2. Antenna type: Built-in PCB antenna is available.
3. Wireless 802.11 b/g/n standard
4. Wi-Fi at 2.4GHz, support WPA / WPA2 security mode
5. Support STA/AP/STA + AP three operating modes
6. Built-in TCP/IP protocol stack to support multiple TCP Client connections (5 MAX)
7. D0 ~ D8, SD1 ~ SD3: used as GPIO, PWM, IIC, etc., port driver capability 15mA
8. AD0: 1 channel ADC
9. Power input: 4.5V ~ 9V (10VMAX), USB-powered
10. Current: continuous transmission:  $\approx 70\text{mA}$  (200mA MAX), Standby:  $< 200\mu\text{A}$

## 3.3 L293D Motor Driver IC

The **L293D** is a popular 16-Pin **Motor Driver IC**. As the name suggests it is mainly used to drive **motors**. A single **L293D** IC is capable of running two DC **motors** at the same time; also the direction of these two **motors** can be controlled independently.

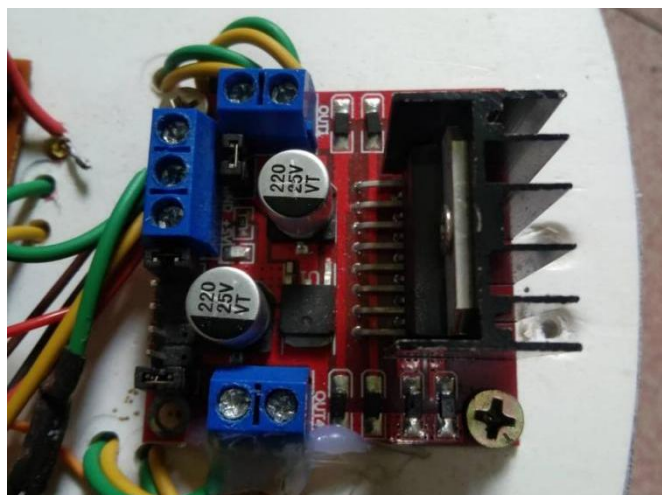

Figure 3.4: Motor driver IC L293D

## Working Process:

**L293D** IC is a typical **Motor Driver** IC which allows the DC **motor** to drive on any direction. This IC consists of 16-pins which are used to control a set of two DC **motors** instantaneously in any direction. It means, by using a **L293D** IC we can control two DC **motors**.

## Features

- Can be used to run Two DC motors with the same IC.
- Speed and Direction control is possible
- Motor voltage  $V_{cc2}$  (Vs): 4.5V to 36V
- Maximum Peak motor current: 1.2A
- Maximum Continuous Motor Current: 600mA
- Supply Voltage to  $V_{cc1}(vss)$ : 4.5V to 7V
- Transition time: 300ns (at 5V and 24V)
- Automatic Thermal shutdown is available

## L293D Pin Configuration

Pin Number	Pin Name	Description
1	Enable 1,2	This pin enables the input pin Input 1(2) and Input 2(7)
2	Input 1	Directly controls the Output 1 pin. Controlled by digital circuits
3	Output 1	Connected to one end of Motor 1
4	Ground	Ground pins are connected to ground of circuit (0V)
5	Ground	Ground pins are connected to ground of circuit (0V)
6	Output 2	Connected to another end of Motor 1
7	Input 2	Directly controls the Output 2 pin. Controlled by digital circuits
8	$V_{cc2}$ (Vs)	Connected to Voltage pin for running motors (4.5V to 36V)

9	Enable 3,4	This pin enables the input pin Input 3(10) and Input 4(15)
10	Input 3	Directly controls the Output 3 pin. Controlled by digital circuits
11	Output 3	Connected to one end of Motor 2
12	Ground	Ground pins are connected to ground of circuit (0V)
13	Ground	Ground pins are connected to ground of circuit (0V)
14	Output 4	Connected to another end of Motor 2
15	Input 4	Directly controls the Output 4 pin. Controlled by digital circuits
16	Vcc2 (Vss)	Connected to +5V to enable IC function

### Use of a L293D Motor Driver IC:

Using this L293D motor driver IC is very simple. The IC works on the principle of **Half H-Bridge**, let us not go too deep into what H-Bridge means, but for now just know that H bridge is a set up which is used to run motors both in clock wise and anti clockwise direction. As said earlier this IC is capable of running two motors at the any direction at the same time, the circuit to achieve the same is shown below.

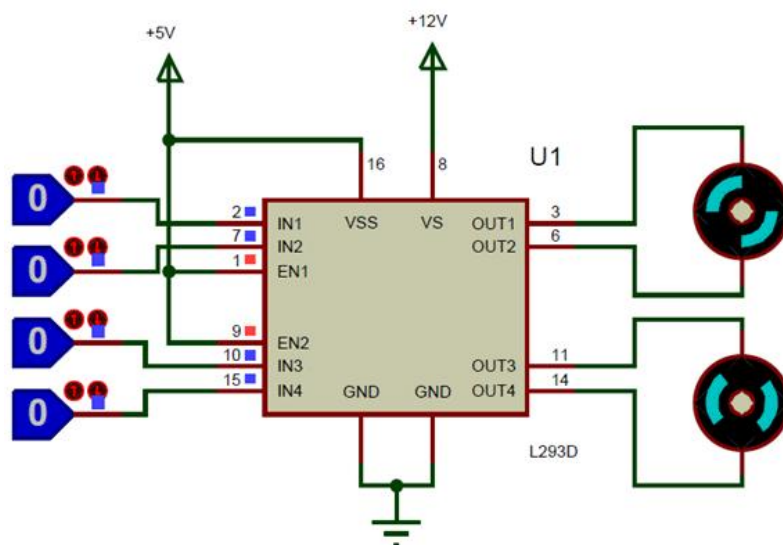

Figure 3.5: L293D circuit Diagram



All the Ground pins should be grounded. There are two power pins for this IC, one is the  $V_{ss}(V_{cc1})$  which provides the voltage for the IC to work, this must be connected to +5V. The other is  $V_s(V_{cc2})$  which provides voltage for the motors to run, based on the specification of your motor you can connect this pin to anywhere between 4.5V to 36V, here I have connected to +12V.

The Enable pins (Enable 1,2 and Enable 3,4) are used to Enable Input pins for Motor 1 and Motor 2 respectively. Since in most cases we will be using both the motors both the pins are held high by default by connecting to +5V supply. The input pins Input 1,2 are used to control the motor 1 and Input pins 3,4 are used to control the Motor 2. The input pins are connected to the any Digital circuit or micro controller to control the speed and direction of the motor.

## **Applications**

- Used to drive high current Motors using Digital Circuits
- Can be used to drive Stepper motors
- High current LED's can be driven
- Relay Driver module (Latching Relay is possible)

### **3.4 DC Gear Motor**

Gear motors are mechanisms that adjust the speed of electric motors, leading them to operate at a certain speed. They are composed of a series of gears that make up a kinematic chain, working on a set of rotary parts.

Their main purpose is to allow the reduction from an initial high speed to a lower one without negatively affecting the mechanism. In addition to this adjustment, a gear motor is in charge of adjusting the mechanical power of a system.

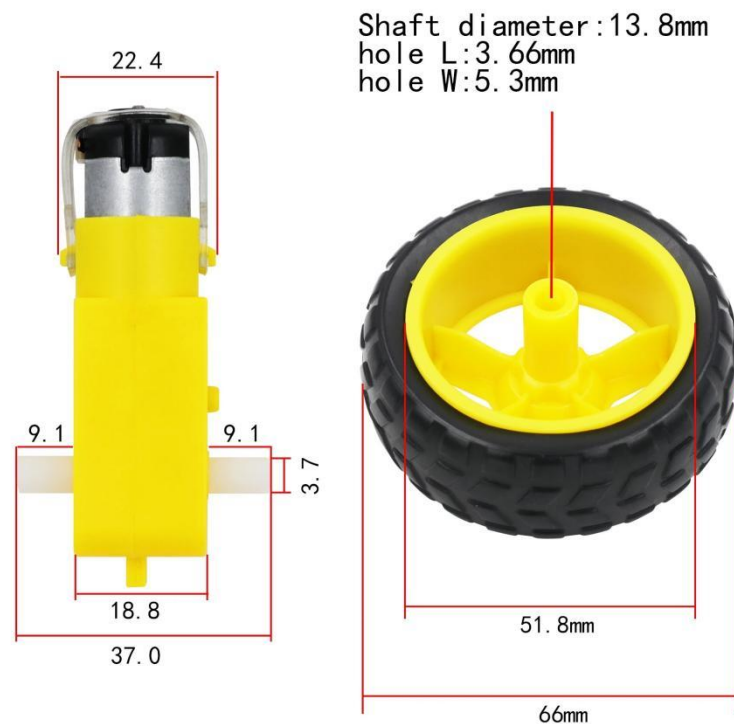

Figure 3.6: Gear Motor

### **Mechanical components that complement gear motors**

Gear motors are composed of an electric motor and gears, which form the kinematic chain – the fundamental component of the gear ratio.

### **Kinematic chain**

A motor's speed reducer is composed of a speed reducer and its gears. This speed reducer is basically a variable speed drive that allows for the speed to be reduced and increased at the output shaft.

### **Gears**

Gears are toothed wheels made of metal or plastic (and new materials with each passing day) that transmit motion when meshing with each other. They are defined by their number of teeth and their size. In addition, they may have straight-cut or helical teeth.

### **Motors**

The five types of motors that see the most use in gear motors are:

- Brushed motors, with brushes normally made out of carbon. They are bidirectional and may be used with DC or AC. They have a service life of about 3000 hours.
- Asynchronous motors, which are brush less single-direction motors. They are highly limited.
- Synchronous brush less motors, which may be single-direction or bidirectional. They have a constant speed if the frequency of the power source is stable.
- Brush less DC motors that use a driver and can attain high speeds.
- Stepper DC brush less motors. They can be positioned with an average precision of 7.5°.

### 3.5 Battery

A lithium battery is the first battery to use a metal lithium anode. This type of battery is also called a lithium metal battery. They differ from other batteries in charging density and high unit cost.



Figure 3.7: 3.7V Battery

## Product Specification

Output Voltage	3.7 V
Product Quality	Lithium-ion
Battery Capacity	2200mAh
Weight	45g
Model Number	ICR 18650

### 3.6 Arduino Software

The digital microcontroller unit named as Arduino Nano can be programmed with the Arduino software IDE. There is no any requirement for installing other software rather than Arduino. Firstly, Select "Arduino Nano from the Tools, Board menu (according to the microcontroller on our board). The IC used named as ATmega328 on the Arduino Nano comes pre burned with a boot loader that allows us to upload new code to it without the use of an external hardware programmer. Communication is using the original STK500 protocol (reference, C header files). We can also bypass the boot loader and programs the microcontroller through the ICSP (In Circuit Serial Programming) header. The ATmega16U2 (or 8U2 in the rev1 and rev2 boards) firmware source code is available. The ATmega16U2/8U2 is loaded with a DFU boot loader, which can be activated by:

On Rev1 boards: connecting the solder jumper on the back of the board (near the map of Italy) and then resetting the 8U2. On Rev2 or later boards: there is a resistor that pulling the 8U2/16U2 HWB line to ground, making it easier to put into DFU mode.

The Arduino Nano is one of the latest digital microcontroller units and has a number of facilities for communicating with a computer, another Arduino, or other microcontrollers. The ATmega328 provides UART TTL at (5V) with serial communication, which is available on digital pins 0 -(RX) for receive the data and pin no.1 (TX) for transmit the data. An ATmega16U2 on the board channels this serial communication over USB and

appears as a virtual com port to software on the computer. The '16U2 firmware uses the standard USB COM drivers, and no external driver is needed. However, on Windows, an .in file is required. The Arduino software includes a serial monitor which allows simple textual data to be sent to and from the Arduino board.

The RX and TX LEDs on the board will flash when data is being transmitted via the USB-to-serial chip and USB connection to the computer (but not for serial Communication on pins 0 and 1). A Software Serial library allows for serial communication on any of the Nano's digital pins. The ATmega328 also supports I2C (TWI) and SPI communication. The Arduino software includes a Wire library to simplify use of the I2C bus. Arduino programs are written in C or C++ and the program code written for Arduino is called sketch. The Arduino IDE uses the GNU tool chain and AVR Lab to compile programs.

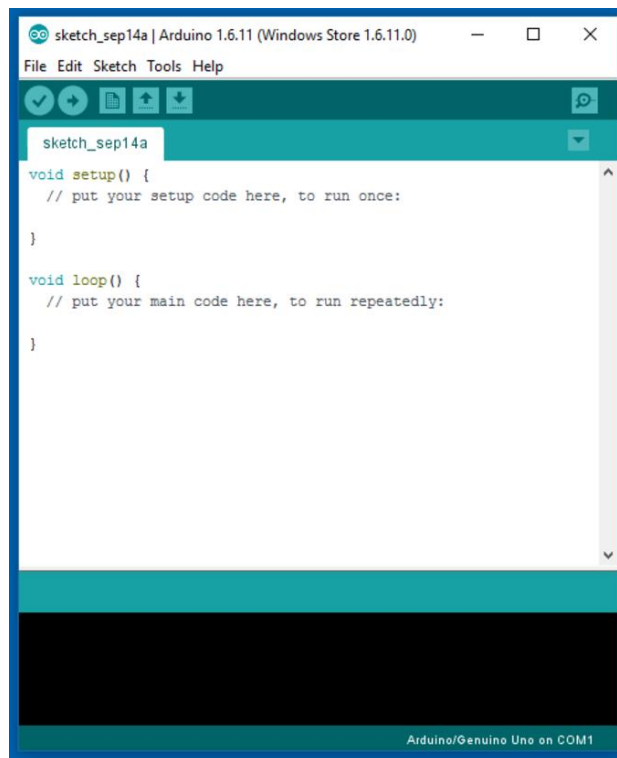

Figure 3.8: Arduino Software Interface IDE

## Writing Sketches

Programs written using Arduino Software (IDE) are called sketches. These sketches are written in the text editor and are saved with the file extension ino. The editor has features for cutting/pasting and for searching/replacing text. The message area gives feedback while saving and exporting and also displays errors. The console displays text output by

the Arduino Software (IDE), including complete error messages and other information. The bottom right hand corner of the window displays the configured board and serial port. The toolbar buttons allow you to verify and upload programs, create, open, and save sketches, and open the serial monitor.

### **Libraries**

Libraries provide extra functionality for use in sketches, e.g. working with hardware or manipulating data. To use a library in a sketch, select it from the Sketch > Import Library menu. This will insert one or more `#include` statements at the top of the sketch and compile the library with your sketch. Because libraries are uploaded to the board with your sketch, they increase the amount of space it takes up. If a sketch no longer needs a library, simply delete its `#include` statements from the top of your code. There is a list of libraries in the reference. Some libraries are included with the Arduino software. Others can be downloaded from a variety of sources or through the Library Manager. Starting with version 1.0.5 of the IDE, you do can import a library from a zip file and use it in an open sketch. See these instructions for installing a third-party library.

### **Third-Party Hardware**

Support for third-party hardware can be added to the hardware directory of your sketchbook directory. Platforms installed there may include board definitions (which appear in the board menu), core libraries, boot loaders, and programmer definitions. To install, create the hardware directory, then unzip the third-party platform into its own sub-directory. (Don't use "arduino" as the sub-directory name or you'll override the built-in Arduino platform.) To uninstall, simply delete its directory.

## **3.7 Proteus Software**

The Proteus Design Suite is a proprietary software tool suite used primarily for electronic design automation. The software is used mainly by electronics design engineers and technicians to create schematics and electronics prints for manufacturing printed circuit boards. The first version of what is now the Proteus Design Suite was called PC-B and was written by the company chairman, John Jameson, for DOS in 1988. Schematic Capture support followed in 1990 with a port to the Windows environment shortly thereafter.

Mixed mode SPICE Simulation was first integrated into Proteus in 1996 and microcontroller simulation then arrived in Proteus in 1998. Shape based auto routing was added in 2002 and 2006 saw another major product update with 3D Board Visualization. More recently, a dedicated IDE for simulation was added in 2011 and MCAD import/export was included in 2015. Support for high speed design was added in 2017.

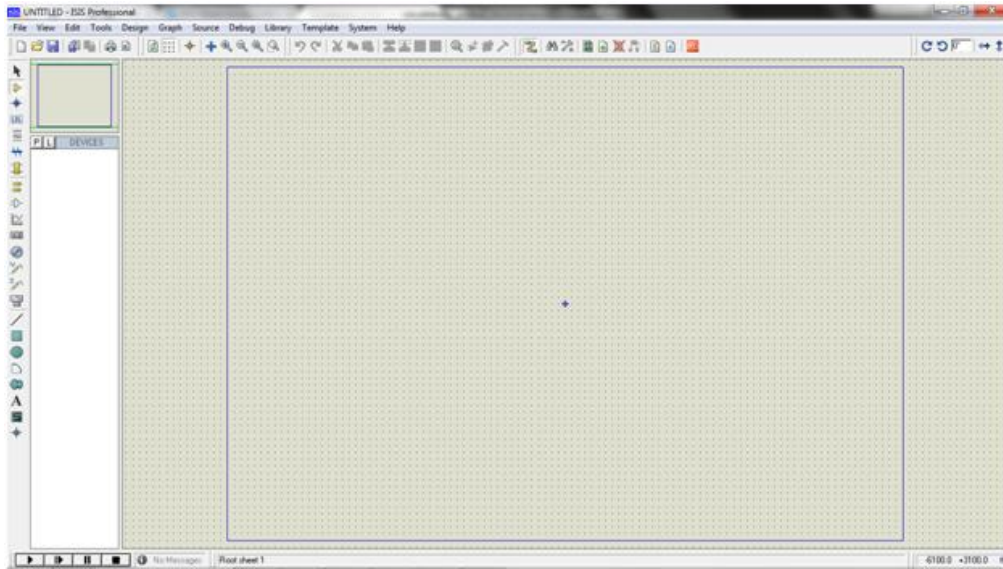

Figure 3.9: Proteus Design of our Skimmer Circuit

### 3.8 Blynk App

Blynk is an **Internet-of-Things** platform designed to make development and implementation of smart IoT devices quick and easy. It can be used to read, store, and visualize sensor data and control hardware remotely.



Figure 3.10: Blynk App

Internet of Things has been all the buzz lately and more and more devices are being talking to internet every day. With the rise of such amazing technology, the risk of security has also increased substantially. Some of the major concerns in IoT are:

- If IoT devices are sending your data to the internet, the communication needs to be closed and encrypted which cannot be possible without using a dedicated and closed server which is really hard to manage.
- The IoT devices also need to be responsive and again, that is not possible without a server with low latency and high responsiveness.
- In IoT, the platform needs to be compatible with many different types of hardware architecture and devices, so that it doesn't restrict its users with single type of hardware with limited capabilities.

**Blynk App** – The mobile app developed by Blynk works as a control panel for visualizing and controlling your hardware. It is available for both Android and iOS. The app offers a very productive interface and various different widgets for different purposes. Blynk works on a currency of its own called energy. New users get 2000 amount of Blynk energy with a free Blynk account and this energy is used to buy and deploy widgets in the projects.



**Blynk Server** – The most amazing component of the Blynk Platform which makes it all possible is the Blynk Server. Blynk offers a secure, responsive and centralized cloud service through its server which allows all of this communication between the devices. The Blynk server is also available as open source so you can literally make your own server and make it even more secure with a little tinkering.

**Blynk Library** – The key feature of Blynk platform which makes it scalable and amazing, is the Blynk Library. The Blynk Library makes it possible to connect your hardware and get it up and running in a blink. The support for multiple hardware devices including **Arduino**, **ESP8266** and **Raspberry Pi** is included in the library and it also makes it possible to connect with hardware through many different ways of communication like Wi-Fi, Bluetooth, BLE, USB and GSM.

## Features

- Similar API & UI for all supported hardware & devices
- Connection to the cloud using:
  - Wi-Fi
  - Bluetooth and BLE
  - Ethernet
  - USB (Serial)
  - GSM
  - Set of easy-to-use Widgets
- Direct pin manipulation with no code writing
- Easy to integrate and add new functionality using virtual pins
- History data monitoring via Super Chart widget
- Device-to-Device communication using Bridge Widget
- Sending emails, tweets, push notifications, etc.

## CHAPTER 4 METHODOLOGY

### 4.1 Our Methodologies for the project

Our methodologies for the project:

- Creating an idea for design and construction of **Belt Type Oil Skimmer**. And designing a block diagram & circuit diagram to know which components we need to construct it.
- Collecting all the components and programming the micro-controller to control the whole system.
- Setting up all the components in a PCB board & then soldering. Lastly, assembling all the blocks in a board and to run the system & for checking purposes.

### 4.2 Block Diagram

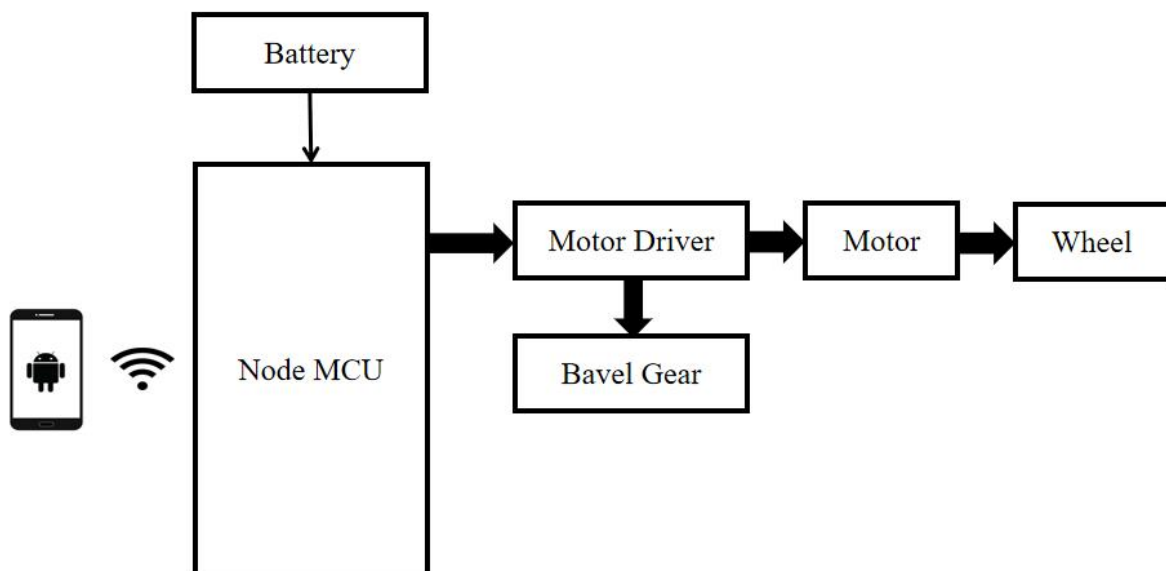

Figure 4.1: Block Diagram

### 4.3 Circuit Diagram of proposed Model:

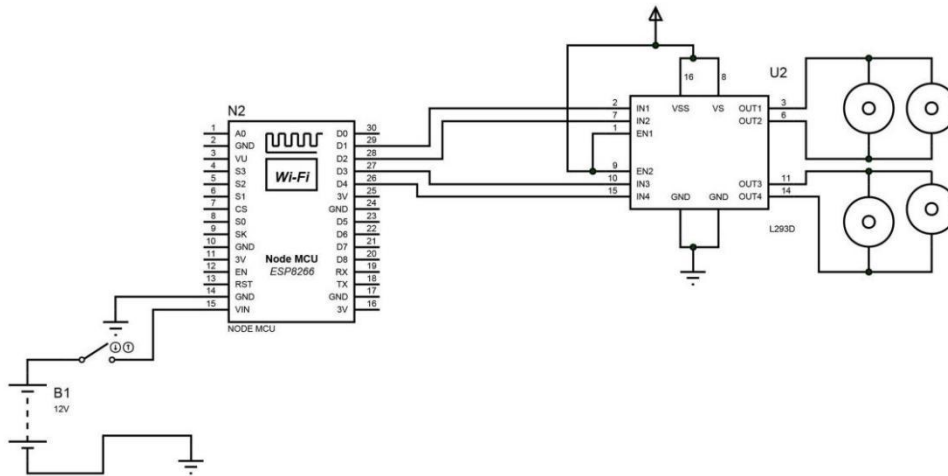

Figure 4.2: Circuit Design

### 4.4 Working Principle

Our project main power will be supply from battery. Here we try to make a project which is Car Suspension System Using Bevel Gears. Here we use motor driver, motor, wheel, bevel gear mechanism, battery. Our System will be powered from battery and supply voltage to the motor driver. This vehicle will move with the mobile phone through IoT system. This vehicle will move to the rough way with out any habitation. Car chassis will be no damage. This is the main procedure of our system.

## 4.5 Real View of project



Figure 4.3: Our Project Prototype

## **CHAPTER 5**

### **BENEFITS OF BEVEL GEAR**

#### **5.1 Advantages**

There are many advantages of our project because of its accuracy. Some of the advantages are pointed out below:

- Its able to move in rough road in without hassle
- Bevel gear helps to move smoothly
- Car motion divided in two shaft which are at right angle.
- The vehicle arrangement is very compact
- Easy Mechanism and Construction.
- Speed can be increased.
- Economical
- Comfort riding experience

#### **5.2 Disadvantages**

1. The torque of the motor is low so it is a little difficult to turn left and right.
2. Our system is controlled by IoT so it always needs internet connection. It cannot run without internet connection.
3. No extra power in this system. If battery discharge fully then the system will stop.

#### **5.3 Why we used bevel gear**

- The Biggest Benefit To Using Bevel Gears Is Their Mechanical Advantage, We Can Increase Or Decrease The Tooth Ratio Between The Drive And Any Accompanying Wheel.
- Ideal For Limited Installation Space
- Compact Design
- Can Be Combined With Other Types Of Gearbox
- Fast Speeds When Spiral Bevel Gears Are Used
- Lower Cost

## 5.4 How Are Bevel Gear Different Other

We Know About Many Types Of Gears, Each Of Which Are Best Suited For A Different Purpose. In Addition To Standard Spur Gears, And Their Close Counterparts Helical Gears, We're Also Known For Bevel Gears. These Are Special Types Of Gears Where Two Different Shaft Axes Intersect At An Angle, And Where The Pitch Surface Is Shaped Like A Cone

## 5.5 Why bevel gear is better than spring

- Day by day spring loose it shape and stability.
- Sometimes when the axial load of the spring is increased it produce the buckling phenomena
- If spring is broken then it is hard to repair.

## 5.6 Other place where bevel gear used

- Aerospace
- Air Pre-heater
- Cement Mills
- Cone Crushers & Sand Mixer
- Cooling Tower
- Marine
- Packaging & Food Processing
  - *Pharmaceutical Packaging Machines*
  - *Can Production equipment*
  - *Polythene Foil Production*
  - *Specially designed gearboxes*
- Printing
- Railways
- Robotics

**CHAPTER- 6**  
**RESULT AND DISCUSSION**

**6.1 WEIGHT STABILITY**

<b>Number</b>	<b>Weight (gm)</b>	<b>Stability/Instability</b>
1	250	Stable
2	500	Stable
3	750	Stable
4	1000	Stable
5	1250	Instable

### 6.2 Front Wheel (Left Side)

<b>Number</b>	<b>Height to over(mm)</b>	<b>Stability/Instability</b>
1	50	Stable
2	80	Stable
3	110	Stable
4	160	Stable
5	180	Instable

### 6.3 Front Wheel (Right Side)

<b>Number</b>	<b>Height to over(mm)</b>	<b>Stability/Instability</b>
1	50	Stable
2	80	Stable
3	110	Stable
4	160	Stable
5	180	Instable



#### 6.4 Back Wheel (Left Side)

<b>Number</b>	<b>Height to over (mm)</b>	<b>Stability/Instability</b>
1	50	Stable
2	80	Stable
3	100	Stable
4	150	Stable
5	170	Instable

#### 6.5 Back Wheel (Right Side)

<b>Number</b>	<b>Height to over (mm)</b>	<b>Stability/Instability</b>
1	50	Stable
2	80	Stable
3	100	Stable
4	150	Stable
5	170	Instable

### 6.6 Front Wheel (Both Side)

<b>Number</b>	<b>Height to over (mm)</b>	<b>Stability/Instability</b>
1	50	Stable
2	100	Stable
3	150	Stable
4	200	Stable
5	220	Instable

### 6.7 Back Wheel (Both Side)

<b>Number</b>	<b>Height to over (mm)</b>	<b>Stability/Instability</b>
1	50	Stable
2	80	Stable
3	100	Stable
4	130	Stable
5	150	Instable

## 6.8 Result

After making our project we observe it very carefully. It works very nicely. Our project give output perfectly and all equipment are work nicely. We check how much it works and we get perfect output from this project.

Finally, we have completed our project successfully & check our project its run accurately according to our objective.

At first, we connect the battery power.

Then when we start the switch then motor will be rotate.

Then from mobile phone we will able to move the car any where.

**Finally we gets result.**

- *Front left wheel is stable up to 160 mm.*
- *Front right wheel is stable up to 160 mm.*
- *Rear left wheel is stable up to 150 mm.*
- *Rear right wheel is stable up to 150 mm.*
- *Two front wheels are stable up to 200 mm together.*
- *The two rear wheels are stable up to 130 mm.*

## 6.9 Discussion

While working on our project, we did face some difficulties as it is a very complex system but the end results, we came up with were quite satisfactory. We have put the whole system through several tasks to validate our work and also have taken necessary notes for future improvements. Some future recommendations that we have involves improvement in system design and wiring, adding features for more efficient.

## 6.10 Application

The application areas for this project in this modern and practical world are huge and some of these are given below:

Its use any kind of vehicle to move smoothly in rough road

## **CHAPTER-7**

### **CONCLUSION**

#### **7.1 Conclusion**

This is a innovative system that could be installed in our vehicle which is used for our daily usage. This idea can an attractive one, people came to know about the mechanism which is been followed behind this concept. The system is designed for all types of locomotion in automobile. This Car Suspension system using bevel gear vehicle able to move in rough and straight road smoothly.

#### **7.2 Future Scope**

We are thinking about adding many features to our project in the future to get more desirable out comes. Some of the steps that we are thinking about taking are given below:

- In future we will add some sensor to measure vehicle condition..
- In future we will add camera monitoring System to view area..
- In future we will add protection equipment to protect this system from any kind of hazard.

## REFERENCE

- [1] Jan Klingelberg. *Bevel gear, Design, production process and technologies are discussed* Springer: Berlin/Heidelberg, Germany, 2016.
- [2] Litvin, Faydor L., Alfonso Fuentes, and Kenichi Hayasaka. "Design, manufacture, stress analysis, and experimental tests of low-noise high endurance spiral bevel gears." *Mechanism and Machine Theory* 41, no. 1 (2006): 83-118.
- [3] Argyris, John, Alfonso Fuentes, and Faydor L. Litvin. "Computerized integrated approach for design and stress analysis of spiral bevel gears." *Computer methods in applied mechanics and engineering* 191, no. 11-12 (2002): 1057-1095.
- [4] Fuentes, Alfonso, Faydor L. Litvin, Baxter R. Mullins, Ron Woods, and Robert F. Handschuh. "Design and stress analysis of low-noise adjusted bearing contact spiral bevel gears." *J. Mech. Des.* 124, no. 3 (2002): 524-532.
- [5] Coleman, W., E. P. Lehmann, D. W. Mellis, and D. M. Peel. *Advancement of straight and spiral bevel gear technology*. GLEASON WORKS ROCHESTER NY, 1969.
- [6] Xiang, Sitong, Huimin Li, Ming Deng, and Jianguo Yang. "Geometric error analysis and compensation for multi-axis spiral bevel gears milling machine." *Mechanism and Machine Theory* 121 (2018): 59-74.
- [7] Vijayakar, Sandeep. *Contact and Bending Durability Calculation for Spiral-Bevel Gears*. No. GRC-E-DAA-TN31732. 2016.
- [8] Chayoukhi, S. L. A. H., K. A. M. E. L. Mehdi, and A. Zghal. "Wingears: A Software Tool for Check and Design of Bevel Gear." *International Journal of Materials Engineering and Technology* 1, no. 1 (2009): 93-103.