

Design & Construction of Springless Car Suspension System Using Bevel Gears

A report submitted to the department of mechanical engineering for the partial fulfillment of the degree of Bachelor of Science in Mechanical Engineering.

Submitted by

Tanvirul Alam	ID: BME1901017200
Md. Nazmul Hossain	ID: BME1902018355
Md. Ashraful Islam	ID: BME1902018098
Md. Mostaqur Rahman	ID: BME1902018360
Md. Abu Bakar Siddique	ID: BME1902018375
Md. Shahidul Islam	ID: BME1902018095



Supervised by

Nuruzzaman Rakib

(Assistant Professor)

Department of Mechanical Engineering

Sonargaon University (SU)

Dhaka-1215, Bangladesh

January, 2023

APPROVAL

This is to certify that the project on “**Design & Construction of Spring-less Car Suspension System Using Bevel Gears**” by Tanvirul Alam (ID:BME1901017200), Md. Mostaqur Rahman (ID:BME1902018360), Md. Nazmul Hossain (ID: BME1902018355), Md. Abu Bakar Siddique (ID:BME1902018375), Md. Ashraful Islam (ID: BME1902018098), Md. Shahidul Islam (ID: BME1902018095) has been carried out under my supervision. The project has been carried out in partial fulfillment of the requirement of the degree of the Bachelor of Science (B.Sc.) in Mechanical Engineering of years of 2023 and has been approved as to its style and content.

.....

Nuruzzaman Rakib
(Assistant Professor)
Department of Mechanical Engineering
Sonargaon University (SU)

Declaration of Authorship

Bangladesh, hereby declare that the project report title—**Design & Construction of Springless Car Suspension System Using Bevel Gears** is prepared after the completion of our project at —**Design & Construction of Springless Car Suspension System Using Bevel Gears**.

We also declared that the project report is prepared for an academic purpose and has not been submitted by me before of any degree.

We declare that the project report embodies the result of own research work, prepared under the supervision of Nuruzzaman Rakib, Assistant Professor, Department of Mechanical Engineering, Sonargaon University (SU)

We also confirm you this report from any counterfeit and no other student either B.Sc. Or other discipline have submitted partially or whole of it.

Tanvirul Alam

BME1901017200

Md. Mostaqur Rahman

BME1902018360

Md. Nazmul Hossain

BME1902018355

Md. Abu Bakar Siddique

BME1902018375

Md Ashraful Islam

BME1902018098

Md. Shahidul Islam

BME1902018095

ACKNOWLEDGEMENT

First, we started in the name of almighty Allah. This thesis is accomplished under the supervision of Nuruzzaman Rakib, Assistant Professor, Department of Mechanical Engineering, Sonargaon University. It is a great pleasure to acknowledge our profound gratitude and respect to our supervisor for this consistent guidance, encouragement, helpful suggestion, constructive criticism and endless patience through the progress of this work. The successful completion of this thesis would not have been possible without his persistent motivation and continuous guidance.

The author are also grateful to Prof. **Md. Mostofa Hossain**, Head of the Department of Mechanical Engineering and all respect teachers of the Mechanical Engineering Department for their co-operation and significant help for completing the thesis work successfully.

[Authors]

Tanvirul Alam

BME 1901017200

Md. Nazmul Hossain

BME1902018355

Md Ashraful Islam

BME1902018098

Md. Mostaqur Rahman

BME1902018360

Md. Abu Bakar Siddique

BME1902018375

Md. Shahidul Islam

BME1902018095

ABSTRACT

Our Initiative, the suspension system without springs combines an oscillating system and a differential mechanism. A gear train with three driving shafts that has the property that one shaft's rotational speed is equal to the average speed of the others, or a fixed multiple of that average, is said to have a differential. The recurrent or regular fluctuation of a thing is called oscillation. Most of the system's frame is built of mild steel. The tire-supporting frame is free to swivel. The differential is attached to the same frame. A differential mechanism gear becomes the driving gear when it is coupled to a motor. Bevel gears on both sides connect the driving gear to the motor driver. There are two wheels on each side of each gear. There is a separate motor for each wheel. The motor driver ensures that the wheels and gears are turning, and the oscillating feature guarantees that the vehicle is going forward even on rough ground. This system is controlled by RF Controller.

TABLE OF CONTENTS

Approval	i	
Declaration of Authorship	ii	
Acknowledgement	iii	
Abstract	iv	
Table of Content	v	
List of Figure	vii	
CHAPTER-1	INTRODUCTION	01-04
1.1 Introduction		01
1.2 Objectives		03
1.3 Scope of use		03
1.3 Organization of Book		04
CHAPTER-2	LITERATURE REVIEW	05-12
2.1 Introduction		05
2.2 A Brief History		05
2.2 What is a Bevel Gear		05
2.4 A Bevel Gear is Beveled		06
2.5 Type of Bevel Gear		07
2.6 Pros and Cons of the Bevel		08
2.7 Details of the topic		08
2.8 Block Diagram		11
2.9 Schematic Diagram		12
2.10 Summary		12
CHAPTER-3	HARDWARE AND SOFTWARE ANALYSIS	13-30
3.1 Introduction		13
3.2 Components list		13
3.3 Arduino Nano		13
3.4 RF Transceiver		16

3.5 Motor Driver IC	18	
3.6 DC Gear Motor	21	
3.7 HC-05 Bluetooth Module	22	
3.8 Battery	26	
3.9 Arduino Software	28	
3.10 Proteus Software	30	
CHAPTER-4	METHODOLOGY	32-35
4.1 Our Methodology of the Project	32	
4.2 Working Principle	32	
4.3 Final Project Image	33	
4.4 Project Components	35	
CHAPTER-5	RESULT'S AND DISCUSSION	35-38
5.1 Discussion	35	
5.2 Results	35	
5.3 Table Of Data Analysis	37	
5.4 Advantages	37	
5.5 Disadvantages	38	
5.6 Applications	38	
CHAPTER-6	CONCLUSION	39
6.1 Conclusion	39	
6.2 Future Scope of Work	39	
REFERENCE	40	

LIST OF FIGURES

FIGURE NO	FIGURE NAME	PAGE NO
2.1	Straight bevel gear	06
2.2	Spiral bevel gear	06
2.3	Zerol bevel gear	07
2.4	Straight bevel gear	09
2.5	Zerol Bevel Gear	09
2.6	Spiral Bevel Gear	10
2.7	Hypoid Gear	11
2.8	Block Diagram	11
2.9	Circuit Diagram	12
3.1	Arduino Nano	14
3.2	Arduino Nano Schematic Diagram	14
3.3	How Arduino Nano looks like	15
3.4	Micro controller IC AT mega 328p	15
3.5	4-Channel RF Module	17
3.6	Motor driver IC L293D	18
3.7	L293D circuit Diagram	20
3.8	Gear Motor	21
3.9	Bluetooth Module HC-05	23
3.10	HC-05 Bluetooth Module	25
3.11	3.7V Battery	27
3.12	Arduino Software Interface IDE	29
3.13	Proteus Software Interface	31
4.1	Project Final Image Top View	33
4.2	Project Final Image Side View	33
4.3	Ready Project Image With RF Controller	34

4.4	Power Supply System	34
5.1	Project Is Before The Objects	36
5.2	Project Is Moving Over The Object	36
5.3	Car Wheel and Bevel Gear With Dimension	37

CHAPTER 1

INTRODUCTION

1.1 Introduction

Due to its exact transmission and simplicity of control, gear has become the most crucial element in modern production for transmitting motion and power. Common gear uses include robotics, planetary reducers, gear pumps, and function generators. Numerous distinct forms of gear, including the involute gear, the cycloid gear, the spiral bevel gear, and the hypoid gear, among others, have been developed using the gear meshing idea.[1] In the power transmission industry, hypoid bevel gears are frequently employed in a wide range of applications, including ships, helicopters, and automobiles. The importance of them as a part of power transmission in mechanical engineering and mechanical science is widely acknowledged. The machining accuracy and surface quality of a hypoid gear are essential for transmission precision, noise, and dynamic performance, among other things, when operating at high speeds and under intense loads. [2]

The bevel gear is a crucial part of mechanical transmission systems because it divides motion and power between two crossing shafts and is crucial to the equipment's durability. [3] The central-driven bevel gear (CDBG), which is an essential part of the power transmission system in turbo shaft aviation engines, guarantees the engine runs smoothly. In order for the gear transmission system to function, it must operate at a high rate. When complex excitation sources operate at rates lower than the operational speed, a range of modal vibrations in the structural system manifest themselves. Future aircraft engines will be more compact and heavily loaded than those currently in use, which could make this problem more visible. Accidents involving the transmission or even the engine are a risk as well as a high rate of wear on the transmission. [4].

A crucial mechanical part for the transfer of force and motion in mechanical systems is the compound gear shaft, which consists of a bevel gear and a spline. They are frequently discovered in mechanical transmission systems, like those in cars and airplanes. A typical type of shaft component defect is inaccurate coaxiality, and mechanical transmission system designs frequently take this inaccuracy into account. The mechanical transmission device's service life may be drastically reduced as a result of damage from vibration and

noise brought on by a compound gear shaft with a significant coaxiality defect. As a result, for mechanical transmission systems, the timely and precise assessment of component coaxiality has become essential. [5].

The first three steps in the production of aerospace spiral bevel gears are rough machining, such as tooth flank milling and heat deformation, and the final phase is finishing, such as tooth flank grinding. It has always been crucial to adjust machine tool settings as needed in order to achieve high geometric precision in the tooth flank. The current model flank is infinitely close to the planned flank while still matching the geometric requirements of the manufacturing process. This modification technique is assumed to reflect a data-driven adaptive process. The crucial heat treatment method has been created at random, despite the fact that precise prediction and optimization are required for the establishment of high tooth flank geometric precision. It's also conceivable that the heat treatment strategy will significantly affect how precisely the tooth flanks are machined throughout the actual gear production process. [6].

Spiral bevel gears are a type of gear that are frequently used in mechanical equipment, including robots, automation devices, and aircraft. This gear part is typically made using Gleason Work's face-milling technology and then placed into a specialized free-form gear cutting machine for precise cutting. According to grain meshing theory, a gear surface is produced by considering how the cutter and gear move in relation to one another in their individual envelope kinematics. Despite having characteristics in common with other milling techniques and gear generating behaviors, the gear face-milling process stands out as a unique operation. Numerous recent initiatives have focused primarily on machining processes in order to improve cutting performance and further the understanding of mechanics. These studies have all looked into chip form mechanics, cutting force prediction, and even cutting dynamics [7].

Face-gear drives can be used into the design of a helicopter's primary gear box to significantly reduce weight. Additionally, there are a number of benefits over spiral bevel gears, such as a high gear ratio, the capacity to accommodate a larger range of shaft angle fluctuations, and the absence of axial stress on the spur pinion. Despite this, the intricate tooth surface structure makes precision machining in this way extremely difficult. The creation of face-gear drives for use in power transmission applications has been the subject of extensive research. Face gears are routinely machined or ground; during this process,

simulations of the cylindrical gear meshing with the face gear are frequently used. When it comes to large face gears, this is especially true. [8]

1.2 Objectives

The objectives of this project are:

- To study about Design & Construction of Springless Car Suspension System Using Bevel Gears.
- To implement a Springless Car Suspension system.
- To implement bevel gear.
- To control the vehicle with RF controller.
- To test the performance of the system.

1.3 Scopes of use

- Reducing oil waste
- Smoothly navigate any hilly terrain.

1.4 Structure of the Project

This Project is organized as follows:

Chapter 1 Introduction: The first chapter contains the statement of the introduction, our background study for the project, problem statement, objectives of the study and the project outline.

Chapter 2 Literature Review: The chapter two contains our introduction, literature review part.

Chapter 3 Hardware and Software Analysis: Chapter three describes the theoretical model. Here we mainly discuss about proposed system Hardware and software development of our project etc.

Chapter 3 Methodology: Chapter three describes the theoretical model. Here we mainly discuss about proposed system architecture in details with having block diagram, circuit diagram, structural diagram, project working principle, complete project image etc.

Chapter 4 Result and Discussion: Chapter four deals with the result and discussion and discuss about our project advantages and application.

Chapter 5 Conclusion: Chapter five all about our project conclusion and future scope.

CHAPTER 2

ABOUT BEVEL GEAR

2.1 Introduction

This chapter is arranged on details of bevel gear. By reading them, we can overcome the mistakes of the previous project and make a more effective project.

2.2 A Brief History

Humanity has been using gears since the early 400 B.C. Similar to how they are used now, the Chinese first employed them for jobs involving the transfer of power through rotation. One of the earliest examples was the Chinese South-Pointing Chariot, a two-wheeled machine with a moving indicator that, without the aid of magnets, always pointed southward no matter which way the chariot turned. The fundamentals are still the same, but technology has advanced greatly. This innovation was brought forth by the industrial revolution of the eighteenth century. The bevel gear was created together with many other innovative designs, such as the involute curve.

2.3 What is a Bevel gear?

Bevel gears are useful when the direction of a shaft's rotation needs to be changed. They are usually mounted on shafts that are 90 degrees apart, but can be designed to work at other angles as well. The picture on the right shows how bevel gears are used to change direction. They change the transmission of the power or torque from one plane to another, which is different from conventional gears that transfer rotations within a single two dimensional plane.

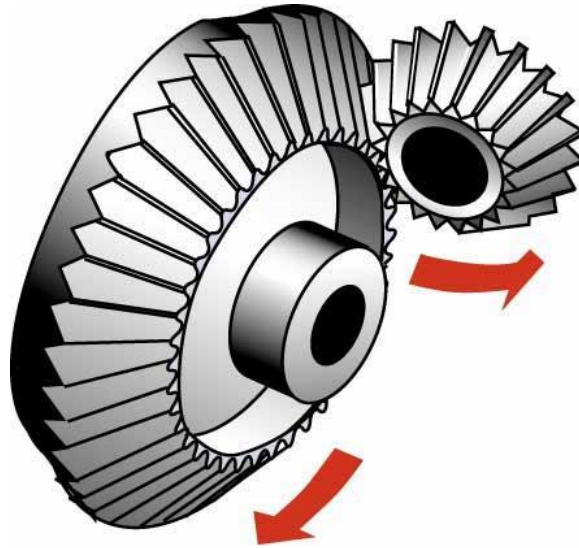

Figure 2.1: Straight bevel gear

2.4 A Bevel gear is ‘Beveled’

As the term “bevel” would suggest, the face of a bevel gear is angled. Typically, a bevel gear is **conical** in shape, with the teeth running along the side of the cone, and the angle of the sides can be varied, depending on the application for the gear.

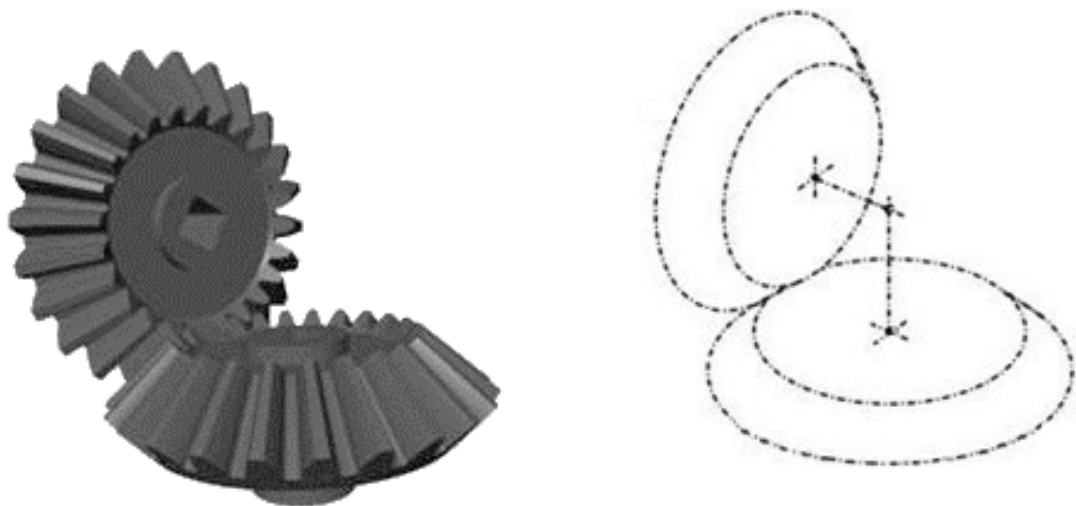

Figure 2.2: Spiral bevel gear

2.5 Types of Bevel Gears

There are 4 commonly known types of bevel gears: Straight bevel gear, Zerol bevel gear, Spiral bevel gear, and lastly the Hypoid bevel gear. These will be discussed in detail later on.



Straight bevel gear Zerol bevel gear Spiral bevel gear Hypoid bevel gear

Another type of bevel gear is the Miter gear. Miter gears are a type of bevel gears that have **equal numbers of teeth**. Miter gears are useful for transmitting rotational motion at a **90 degree** angle with a **1:1 ratio**. Geometrically, a miter bevel gear's teeth can be straight, zerol, or even spiral in shape.



Figure 2.3: Zerol bevel gear

2.6 Pros and Cons of the Bevel Gear

Advantages:

The main advantage of Bevel gears is that the gears make it possible to change the **operating angle**. Through this, aside from transmitting direction alone, you can increase or decrease the torque, force and speed being transmitted by changing or **tweaking the ratio of the teeth**. Secondly, they can be made out of a variety of different materials. **Metal** ones are common in clocks as well as in hand tools such as the handheld drill drivers. However, they can also be made out of **plastic** or **nylon**, and they are more common in electronic machines like toys as well as other components. Gears made with non-metallic materials give noiseless operation at higher speeds.

Disadvantages:

One disadvantage of the Bevel gear is that one wheel of such gear can only work with its **complementary wheel**, and no other. Another downside is that bevel gears need extreme **precision in mounting**. Lastly, the shaft bearings need to be made to support relatively heavier loads or forces

2.7 Details Of The Topic

Four Types of Bevel gear According to Tooth Race

1. Straight Bevel Gear – a bevel gear whose **teeth are straight** but their sides are tapered so that they would intersect the axis at a common point (pitch cone apex) if extended inward.

Features: Easy to manufacture, and provides high reduction ratios: up to 1:5

Applications: Machine tools, printing presses, differential units.



Figure 2.4: Straight bevel gear

2. Zerol Bevel Gear – a bevel gear whose teeth is **curved** but lie in the same direction as the teeth of straight bevel gears. Spiral angle is zero.

Features: These gears normally have a pressure angle of **20 deg**. The minimum number of teeth on the pinion is **14**. The design of Zerol gears is relatively specialized and they are manufactured using special "Gleason" machine tools..

Applications: Essentially used in applications similar to spiral or straight bevel gear, but with **higher accuracy and speed**.



Figure 2.5: Zerol Bevel Gear

3. Spiral Bevel Gear – a bevel gear having **curved oblique teeth** on which contact begins gradually and continues smoothly from end to end.

Features: High strength and durability, reduced gear noise, but involves difficulties in manufacturing.

Applications: Vehicles, final reduction gearing for ships, suitable for high speed and heavy load drives.



Figure 2.6: **Spiral Bevel Gear**

4. Hypoid Gear – is similar to spiral bevel gears; except that the shaft axes are **offset, nonintersecting**.

Features: The minimum number of teeth for speed ratios greater than 6:1 is eight although 6 teeth pinions can be used for ratios below 6:1. Hypoid gears have pressure angles between **19 and 22 deg**.

Applications: Automotive applications, applications that require **smooth and quiet operation**.



Figure 2.7: Hypoid Gear

2.8 Block Diagram

In our project we have set up a **Spring-less Car Suspension System Using Bevel Gears**. In this circuit we have used one RF controller for control this vehicle, motor driver, bevel gear, motor, wheel, battery etc. In this diagram we will show by block the individual parts.

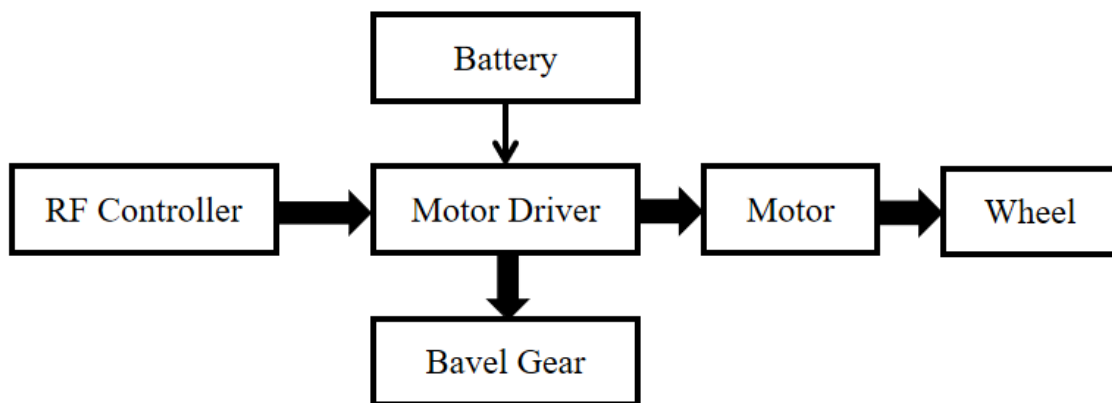

Figure 2.8: Block Diagram

2.9 Schematic Diagram

The schematic diagram here is representing the electrical circuit and the components of the **Design & Construction of Springless Car Suspension System Using Bevel Gears**. Here we connect equipment with be smart wire connection.

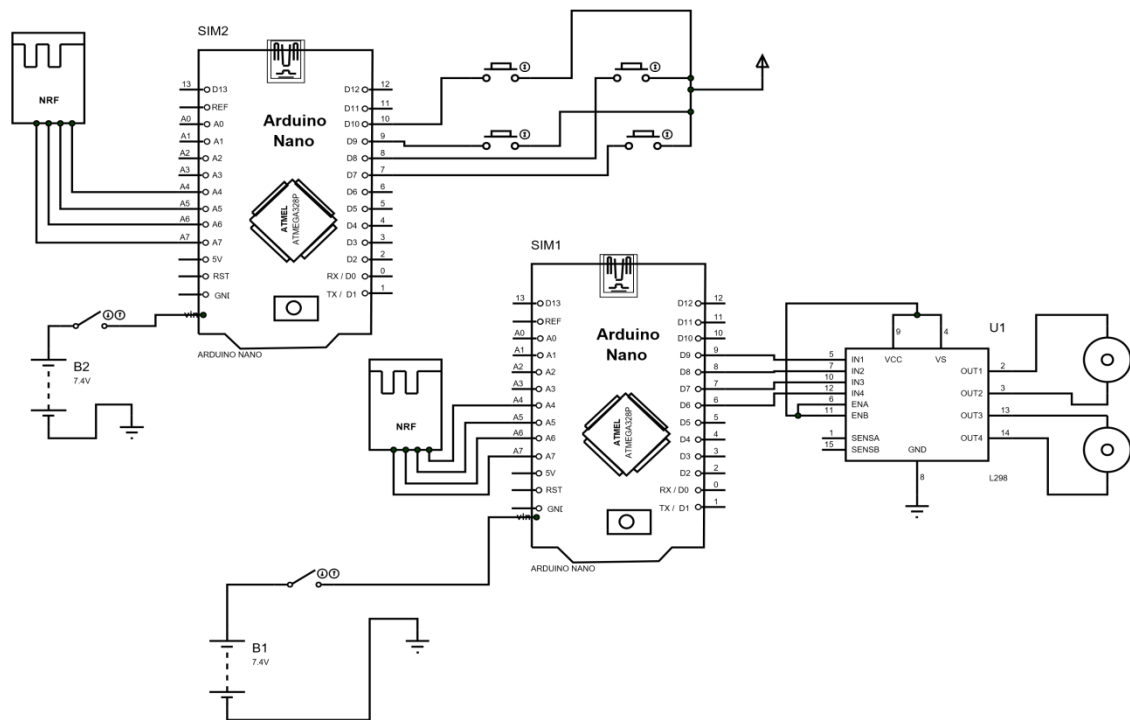

Figure 2.9: Schematic Diagram of our circuit

2.10 Summary

The above discussion gives an idea about the **Design & Construction of Springless Car Suspension System Using Bevel Gears**. All that work on this system has already been done here, and the results of their work, the use of **Design & Construction of Spring-less Car Suspension System Using Bevel Gears** in the situation are described in detail. From this we also got the direction of work of the project.

CHAPTER 3

HARDWARE ANALYSIS

3.1 Introduction

In this section, we will discuss elaborately about our hardware of “**Design & Construction of Spring-less Car Suspension System Using Bevel Gears System**” and the component description, features, working procedure and description of our all equipment.

3.2 Components List:

Hardware Part:

1. RF Controller
2. Motor Driver
3. Arduino Nano
4. Bluetooth Controller
5. Motor
6. Wheel
7. Bevel Gear
8. Battery
9. Hexagonal coupling
10. Frame

Software Part :

1. Proteus Software

3.3 Arduino Nano

Arduino is an open source electronics prototyping platform based on flexible, easy-to-use hardware and software. It's intended for artists, designers, hobbyists, and anyone interested in creating interactive objects or environments. Arduino can sense the environment by

receiving input from a variety of sensors and can affect its surroundings by controlling Lights, motors, and other actuators.

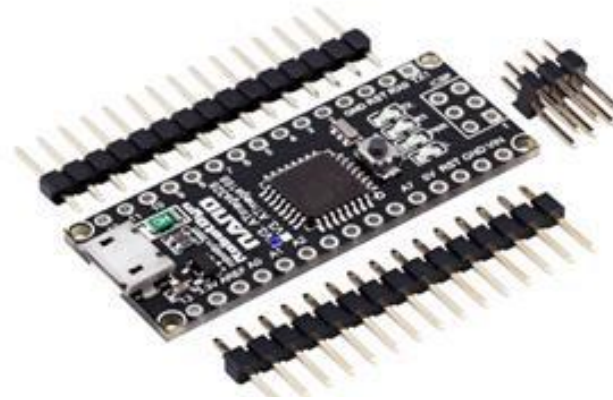

Figure 3.1: Arduino Nano

The micro controller on the board is programmed using the Arduino programming language (based on Wiring) and the Arduino development environment (based on Processing). Arduino projects can be stand-alone or they can communicate with software on running on a computer (e.g. Flash, Processing, Maxims’).

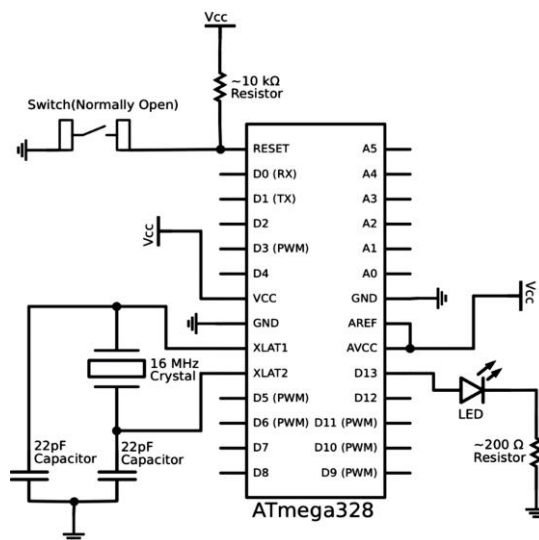

Figure 3.2: Arduino Nano Schematic Diagram

Arduino Nano is a surface mount breadboard embedded version with integrated USB. It is a small, complete, and breadboard friendly component. It has everything that Duemilanove has (electrically) with more analog input pins and onboard +5V AREF jumper. Physically, it is missing power jack. The Nano can automatically sense and switch

to the higher potential source of power. Nano's got the breadboard-ability of the Boarding and the Minibus with smaller footprint than either, so users have more breadboard space. It's got a pin layout that works well with the Mini or the Basic Stamp (TX, RX, ATN, and GND on one top, power and ground on the other).

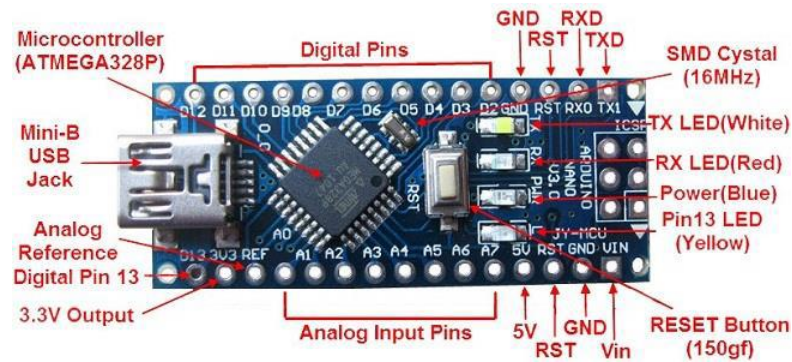

Figure 3.3: How Arduino Nano looks like

Specifications

- Micro controller: Atmel ATmega328
- Operating Voltage (logic level): 5 V
- Input Voltage (recommended): 7-12 V
- Input Voltage (limits): 6-20 V
- Digital I/O Pins: 14 (of which 6 provide PWM output)
- Analog Input Pins: 8
- DC Current per I/O Pin: 40 mA

Micro controller IC ATmega328p



Figure 3.4: Micro controller IC AT mega 328p

Features:

- Automatic reset during program download
- Power OK blue LED
- Green (TX), red (RX) and orange (L) LED
- Auto sensing/switching power input
- Small mini-B USB for programming and serial monitor
- ICSP header for direct program download
- Standard 0.1 spacing DIP (breadboard friendly)
- Manual reset switch

The high-performance Microchip Pico Power 8-bit AVR RISC-based microcontroller combines 32KB ISP flash memory with read-while-write capabilities, 1024B EEPROM, 2KB SRAM, 23 general purpose I/O lines, 32 general purpose working registers, three flexible timer/counters with compare modes, internal and external interrupts, serial programmable USART, a byte-oriented 2-wire serial interface, SPI serial port, a 6-channel 10-bit A/D converter (8-channels in TQFP and QFN/MLF packages), programmable watchdog timer with internal oscillator, and five software selectable power saving modes. The device operates between 1.8-5.5 volts. By executing powerful instructions in a single clock cycle, the device achieves throughputs approaching 1 MIPS per MHz, balancing power consumption and processing speed.

3.4 4-Channel 433 MHz RF Transceiver

4 Channel RF Remote Transmitter and Receiver allows to remotely control four appliances. RF Remote Control provides 4 momentary outputs that can be wired to relays and control home appliances, lights, motors, light dimmers, robotic devices, RC cars, computer, etc. RF transmitter provides up to 150m range. Selection of custom address codes allows to operate more than one remote control system in the same area or to control one receiver with multiple transmitters. If required momentary outputs can be converted to toggle with low cost digital 4013 IC. 12V (27A) alkaline battery is included.

Specifications

- 4 Momentary Outputs
- 150m Transmission Range
- Rock-solid oscillator provides reliable operation
- Valid transmission LED status through VT connection
- High noise immunity
- Standard header connection (breadboard compatible)
- Selection of custom address codes allows to operate more than one unit in the same area or controlling the same receiver with multiple remotes

RF Transmitter Specifications

- Voltage Supply: 12V (Included 27A Alkaline Battery)
- Transmission Frequency: 433MHz
- Transmission Range: 150m

RF Receiver Specifications

- Voltage Supply: 5V
- Transmission Frequency: 433MHz
- Output Mode: Momentary
- Power Consumption: 5 mA
- Receiving Sensitivity: -101 dbm



Figure 3.5: 4-Channel RF Module

3.5 L293D Motor Driver IC

The **L293D** is a popular 16-Pin **Motor Driver IC**. As the name suggests it is mainly used to drive **motors**. A single **L293D** IC is capable of running two DC **motors** at the same time; also the direction of these two **motors** can be controlled independently.

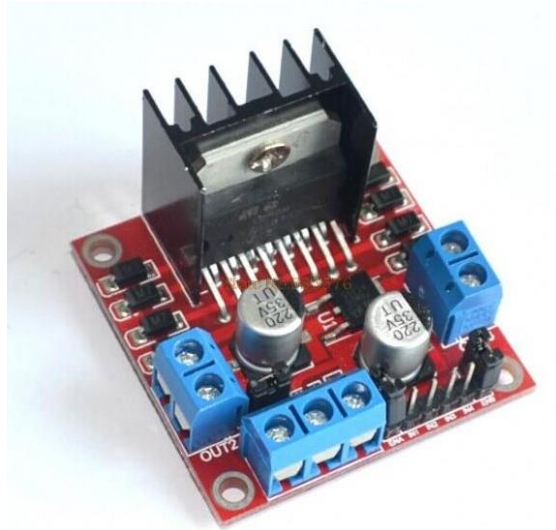

Figure 3.6: Motor driver IC L293D

Working Process:

L293D IC is a typical **Motor Driver IC** which allows the DC **motor** to drive on any direction. This IC consists of 16-pins which are used to control a set of two DC **motors** instantaneously in any direction. It means, by using a **L293D** IC we can control two DC **motors**.

Features

- Can be used to run Two DC motors with the same IC.
- Speed and Direction control is possible
- Motor voltage V_{cc2} (V_s): 4.5V to 36V
- Maximum Peak motor current: 1.2A
- Maximum Continuous Motor Current: 600mA
- Supply Voltage to V_{cc1} (v_{ss}): 4.5V to 7V
- Transition time: 300ns (at 5V and 24V)
- Automatic Thermal shutdown is available

L293D Pin Configuration

Pin Number	Pin Name	Description
1	Enable 1,2	This pin enables the input pin Input 1(2) and Input 2(7)
2	Input 1	Directly controls the Output 1 pin. Controlled by digital circuits
3	Output 1	Connected to one end of Motor 1
4	Ground	Ground pins are connected to ground of circuit (0V)
5	Ground	Ground pins are connected to ground of circuit (0V)
6	Output 2	Connected to another end of Motor 1
7	Input 2	Directly controls the Output 2 pin. Controlled by digital circuits
8	Vcc2 (Vs)	Connected to Voltage pin for running motors (4.5V to 36V)
9	Enable 3,4	This pin enables the input pin Input 3(10) and Input 4(15)
10	Input 3	Directly controls the Output 3 pin. Controlled by digital circuits
11	Output 3	Connected to one end of Motor 2
12	Ground	Ground pins are connected to ground of circuit (0V)
13	Ground	Ground pins are connected to ground of circuit (0V)
14	Output 4	Connected to another end of Motor 2
15	Input 4	Directly controls the Output 4 pin. Controlled by digital circuits
16	Vcc2 (Vss)	Connected to +5V to enable IC function

Use of a L293D Motor Driver IC:

Using this L293D motor driver IC is very simple. The IC works on the principle of **Half H-Bridge**, let us not go too deep into what H-Bridge means, but for now just know that H bridge is a set up which is used to run motors both in clock wise and anti clockwise direction. As said earlier this IC is capable of running two motors at the any direction at the same time, the circuit to achieve the same is shown below.

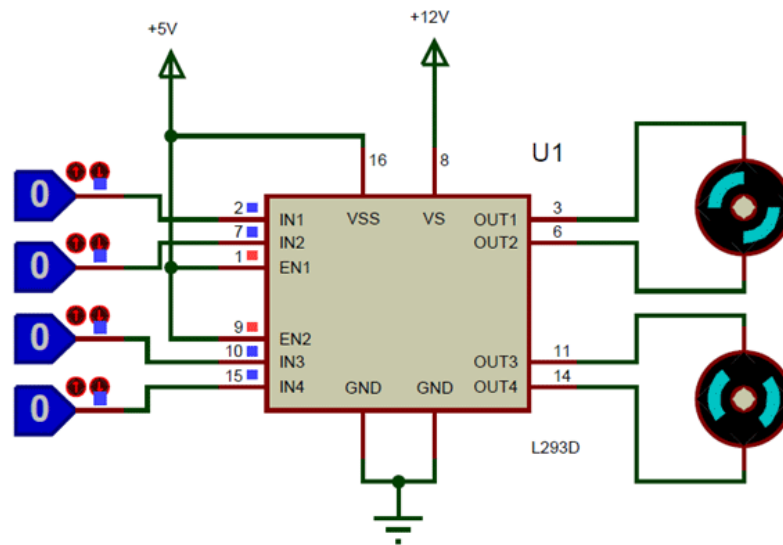

Figure 3.7: L293D circuit Diagram

All the Ground pins should be grounded. There are two power pins for this IC, one is the Vs (Vcc1) which provides the voltage for the IC to work, this must be connected to +5V. The other is Vs (Vcc2) which provides voltage for the motors to run, based on the specification of your motor you can connect this pin to anywhere between 4.5V to 36V, here I have connected to +12V.

The Enable pins (Enable 1,2 and Enable 3,4) are used to Enable Input pins for Motor 1 and Motor 2 respectively. Since in most cases we will be using both the motors both the pins are held high by default by connecting to +5V supply. The input pins Input 1,2 are used to control the motor 1 and Input pins 3,4 are used to control the Motor 2. The input pins are connected to the any Digital circuit or micro controller to control the speed and direction of the motor.

Applications

- Used to drive high current Motors using Digital Circuits
- Can be used to drive Stepper motors
- High current LED's can be driven
- Relay Driver module (Latching Relay is possible)

3.6 DC Gear Motor

Gear motors are mechanisms that adjust the speed of electric motors, leading them to operate at a certain speed. They are composed of a series of gears that make up a kinematic chain, working on a set of rotary parts.

Their main purpose is to allow the reduction from an initial high speed to a lower one without negatively affecting the mechanism. In addition to this adjustment, a gear motor is in charge of adjusting the mechanical power of a system.



Figure 3.8: Gear Motor

Mechanical components that complement gear motors

Gear motors are composed of an electric motor and gears, which form the kinematic chain – the fundamental component of the gear ratio.

Kinematic chain

A motor's speed reducer is composed of a speed reducer and its gears. This speed reducer is basically a variable speed drive that allows for the speed to be reduced and increased at the output shaft.

Gears

Gears are toothed wheels made of metal or plastic (and new materials with each passing day) that transmit motion when meshing with each other. They are defined by their number of teeth and their size. In addition, they may have straight-cut or helical teeth.

Motors

The five types of motors that see the most use in gear motors are:

- Brushed motors, with brushes normally made out of carbon. They are bidirectional and may be used with DC or AC. They have a service life of about 3000 hours.
- Asynchronous motors, which are brush less single-direction motors. They are highly limited.
- Synchronous brush less motors, which may be single-direction or bidirectional. They have a constant speed if the frequency of the power source is stable.
- Brush less DC motors that use a driver and can attain high speeds.

3.7 HC-05 Bluetooth Module

Bluetooth is a wireless technology standard for exchanging data between fixed and mobile devices over short distances using short-wavelength UHF radio waves in the industrial, scientific and medical radio bands, from 2.400 to 2.485 GHz, and building personal area networks.

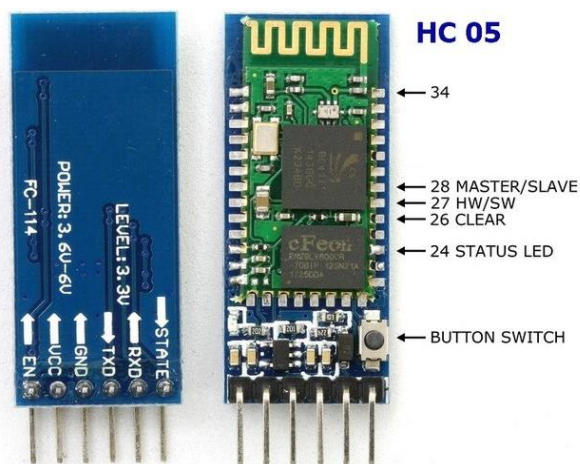

Figure 3.9: Bluetooth Module HC-05

HC-05 Technical Specifications

- Serial Bluetooth module for Arduino and other micro controllers
- Operating Voltage: 4V to 6V (Typically +5V)
- Operating Current: 30mA
- Range: <100m
- Works with Serial communication (USART) and TTL compatible
- Follows IEEE 802.15.1 standardized protocol
- Uses Frequency-Hopping Spread spectrum (FHSS)
- Can operate in Master, Slave or Master/Slave mode
- Can be easily interfaced with Laptop or Mobile phones with Bluetooth
- Supported baud rate: 9600,19200,38400,57600,115200,230400,460800.

Applications

The HC-05 is a very cool module that can add two-way (full dual) wireless functionality to your projects. You can use this module to communicate between two micro controllers, such as Arduino, or to communicate with any device that has Bluetooth functionality, such as a phone or laptop. We can also configure module defaults using command mode. So if you are looking for a wireless module capable of transferring data from your computer or mobile phone to micro controller or vice versa, then this module may be the right choice for you. But don't expect this module to transfer multimedia like pictures or songs; For this you need to look for the CSR 8645 module.

1. Wireless communication between two micro controllers
2. Communicate with Laptop, Desktops and mobile phones
3. Data Logging application
4. Consumer applications
5. Wireless Robots
6. Home Automation

How to Use the HC-05 Bluetooth Module

The HC-05 has two operating modes, one is the data mode which allows it to send and receive data from other Bluetooth devices and the other is the command mode where the default device settings can be changed. We can operate the device in either of these two modes using the PIN key described in the PIN description. Connecting the HC-05 module to micro-controllers is very easy because it operates using the Serial Port Protocol (SPP). Power the module with only + 5V and connect the RX pin of the module to the TX of the MCU and the TX pin of the module to the RX of the MCU as shown in the figure below.

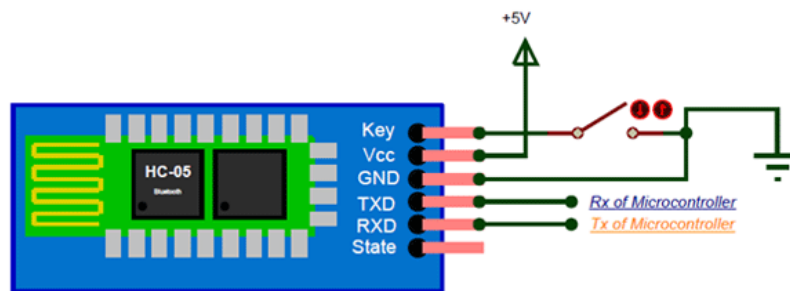

Figure: 3.10 HC-05 Bluetooth Module

During power-up, the key pin can be used to enter the command mode. If this pin is not used, it will enter the data mode by default. After the input module is activated, you should be able to detect the Bluetooth device as "HC-05" and then as the default password. Use 1234 to connect and start communicating with it.

Pin Configuration of HC-05 Bluetooth Module

Pin Number	Pin Name	Description
1	Enable / Key	This pin is used to toggle between Data Mode (set low) and AT command mode (set high). By default it is in Data mode
2	Vcc	Powers the module. Connect to +5V Supply voltage
3	Ground	Ground pin of module, connect to system ground.

4	TX Transmitter	Transmits Serial Data. Everything received via Bluetooth will be given out by this pin as serial data.
5	RX Receiver	Receive Serial Data. Every serial data given to this pin will be broadcasted via Bluetooth
6	State	The state pin is connected to on board LED, it can be used as a feedback to check if Bluetooth is working properly.
7	LED	Indicates the status of Module <ul style="list-style-type: none"> • Blink once in 2 sec: Module has entered Command Mode • Repeated Blinking: Waiting for connection in Data Mode • Blink twice in 1 sec: Connection successful in Data Mode
8	Button	Used to control the Key/Enable pin to toggle between Data and command Mode

3.8 Battery

Lithium batteries are primary batteries that have metallic lithium as an anode. These types of batteries are also referred to as lithium-metal batteries. They stand apart from other batteries in their high charge density and high cost per unit. Depending on the design and chemical compounds used, lithium cells can produce voltages from 1.5 V (comparable to a zinc-carbon or alkaline battery) to about 3.7 V.

Disposable primary lithium batteries must be distinguished from secondary lithium-ion or a lithium-polymer, which are rechargeable batteries. Lithium is especially useful, because its ions can be arranged to move between the anode and the cathode, using an intercalated lithium compound as the cathode material but without using lithium metal as the anode material. Pure lithium will instantly react with water, or even moisture in the air; the lithium in lithium ion batteries is in a less reactive compound.



Figure 3.11: 3.7V Battery

Lithium batteries are widely used in portable consumer electronic devices. The term "lithium battery" refers to a family of different lithium-metal chemistries, comprising many types of cathodes and electrolytes but all with metallic lithium as the anode. The battery requires from 0.15 to 0.3 kg of lithium per kWh. As designed these primary systems use a charged cathode, that being an electro-active material with crystallographic vacancies that are filled gradually during discharge.

Product Specification

Voltage	3.7 V
Product Type	Lithium-Ion
Battery Capacity	2200mAh
Weight	45 g
Model Number	ICR 18650

3.9 Arduino Software

The digital microcontroller unit named as Arduino Nano can be programmed with the Arduino software IDE. There is no any requirement for installing other software rather than Arduino. Firstly, Select "Arduino Nano from the Tools, Board menu (according to the microcontroller on our board). The IC used named as ATmega328 on the Arduino Nano comes pre burned with a boot loader that allows us to upload new code to it without the use of an external hardware programmer. Communication is using the original STK500 protocol (reference, C header files). We can also bypass the boot loader and programs the microcontroller through the ICSP (In Circuit Serial Programming) header. The ATmega16U2 (or 8U2 in the rev1 and rev2 boards) firmware source code is available. The ATmega16U2/8U2 is loaded with a DFU boot loader, which can be activated by:

On Rev1 boards: connecting the solder jumper on the back of the board (near the map of Italy) and then resetting the 8U2. On Rev2 or later boards: there is a resistor that pulling the 8U2/16U2 HWB line to ground, making it easier to put into DFU mode.

The Arduino Nano is one of the latest digital microcontroller units and has a number of facilities for communicating with a computer, another Arduino, or other microcontrollers. The ATmega328 provides UART TTL at (5V) with serial communication, which is available on digital pins 0 -(RX) for receive the data and pin no.1 (TX) for transmit the data. An ATmega16U2 on the board channels this serial communication over USB and appears as a virtual com port to software on the computer. The '16U2 firmware uses the standard USB COM drivers, and no external driver is needed. However, on Windows, an .in file is required. The Arduino software includes a serial monitor which allows simple textual data to be sent to and from the Arduino board.

The RX and TX LEDs on the board will flash when data is being transmitted via the USB-to-serial chip and USB connection to the computer (but not for serial Communication on pins 0 and 1). A Software Serial library allows for serial communication on any of the Nano's digital pins. The ATmega328 also supports I2C (TWI) and SPI communication. The Arduino software includes a Wire library to simplify use of the I2C bus. Arduino programs are written in C or C++ and the program code written for Arduino is called sketch. The Arduino IDE uses the GNU tool chain and AVR Lab to compile programs.

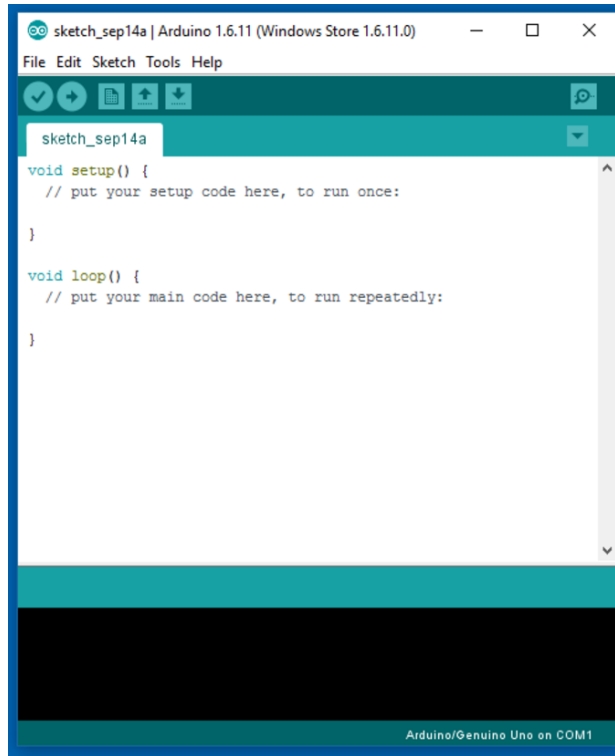

Figure 3.12: Arduino Software Interface IDE

Writing Sketches

Programs written using Arduino Software (IDE) are called sketches. These sketches are written in the text editor and are saved with the file extension. The editor has features for cutting/pasting and for searching/replacing text. The message area gives feedback while saving and exporting and also displays errors. The console displays text output by the Arduino Software (IDE), including complete error messages and other information. The bottom righthand corner of the window displays the configured board and serial port. The toolbar buttons allow you to verify and upload programs, create, open, and save sketches, and open the serial monitor.

Libraries

Libraries provide extra functionality for use in sketches, e.g. working with hardware or manipulating data. To use a library in a sketch, select it from the Sketch > Import Library menu. This will insert one or more `#include` statements at the top of the sketch and compile the library with your sketch. Because libraries are uploaded to the board with your sketch, they increase the amount of space it takes up. If a sketch no longer needs a library, simply delete its `#include` statements from the top of your code. There is a list of libraries in the reference. Some libraries are included with the Arduino software. Others can be downloaded from a variety of sources or through the Library Manager. Starting with version 1.0.5 of the IDE, you do can import a library from a zip file and use it in an open sketch. See these instructions for installing a third-party library.

Third-Party Hardware

Support for third-party hardware can be added to the hardware directory of your sketchbook directory. Platforms installed there may include board definitions (which appear in the board menu), core libraries, boot loaders, and programmer definitions. To install, create the hardware directory, then unzip the third-party platform into its own sub-directory. (Don't use "arduino" as the sub-directory name or you'll override the built-in Arduino platform.) To uninstall, simply delete its directory.

3.10 Proteus Software

The Proteus Design Suite is a proprietary software tool suite used primarily for electronic design automation. The software is used mainly by electronics design engineers and technicians to create schematics and electronics prints for manufacturing printed circuit boards. The first version of what is now the Proteus Design Suite was called PC-B and was written by the company chairman, John Jameson, for DOS in 1988. Schematic Capture support followed in 1990 with a port to the Windows environment shortly thereafter. Mixed mode SPICE Simulation was first integrated into Proteus in 1996 and microcontroller simulation then arrived in Proteus in 1998. Shape based auto routing was added in 2002 and 2006 saw another major product update with 3D Board Visualization. More recently, a dedicated IDE for simulation was added in 2011 and MCAD import/export was included in 2015. Support for high speed design was added in 2017.

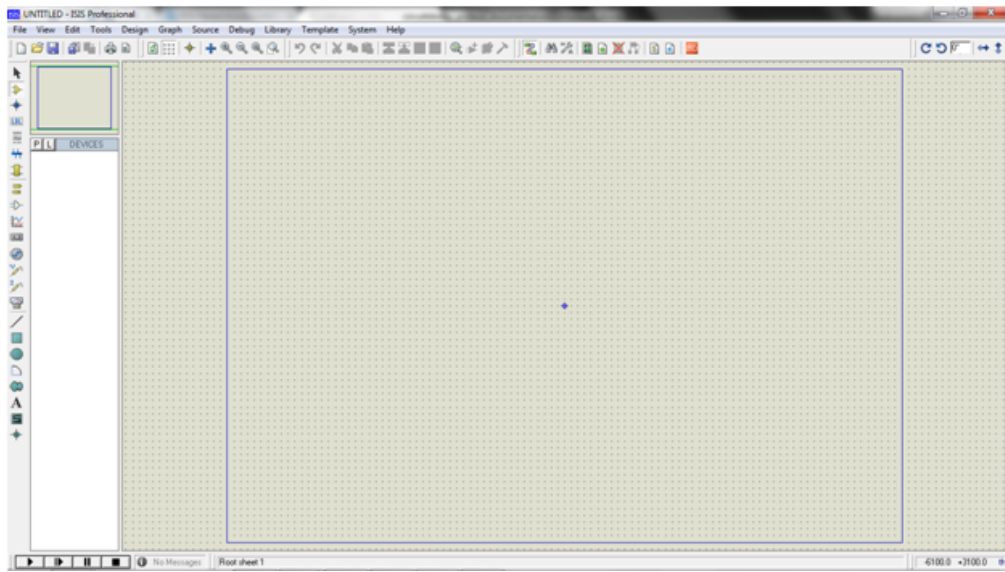

Figure 3.13: Proteus Design of our Skimmer Circuit

CHAPTER 4

METHODOLOGY

4.1 Our methodologies for the project:

- Creating an idea for the **Design & Construction of Spring-less Car Suspension System Using Bevel Gears**. And designing a block diagram to know which components we need to construct it.
- Collecting all the components for our desired system.
- Setting up all the components in a system. Then assembling all the blocks in a system and finally running the system to check if it actually works or not.

4.2 Working Principle

The springless suspension system combines a differential mechanism and an oscillating system. We connected two frame surfaces with three bevel gears through bolts. At the bottom sides of two frames we attached four motors and wheels. Shocks are created when the vehicle moves on rough roads and will be absorbed by the rotation of the gears. The main power will be supplied from battery. Here we use motor driver, motor, wheel, bevel gear mechanism, battery and RF controller. Our system will be powered by a battery and supply voltage to the motor driver. This vehicle will move with the RF controller instruction. This vehicle will move in the rough way without any hesitation. Car chassis will be no damage. This is the main procedure of our system.

4.3 Final Project Image



Figure 4.1: Project Final Image Top View



Figure 4.2: Project Final Image Side View

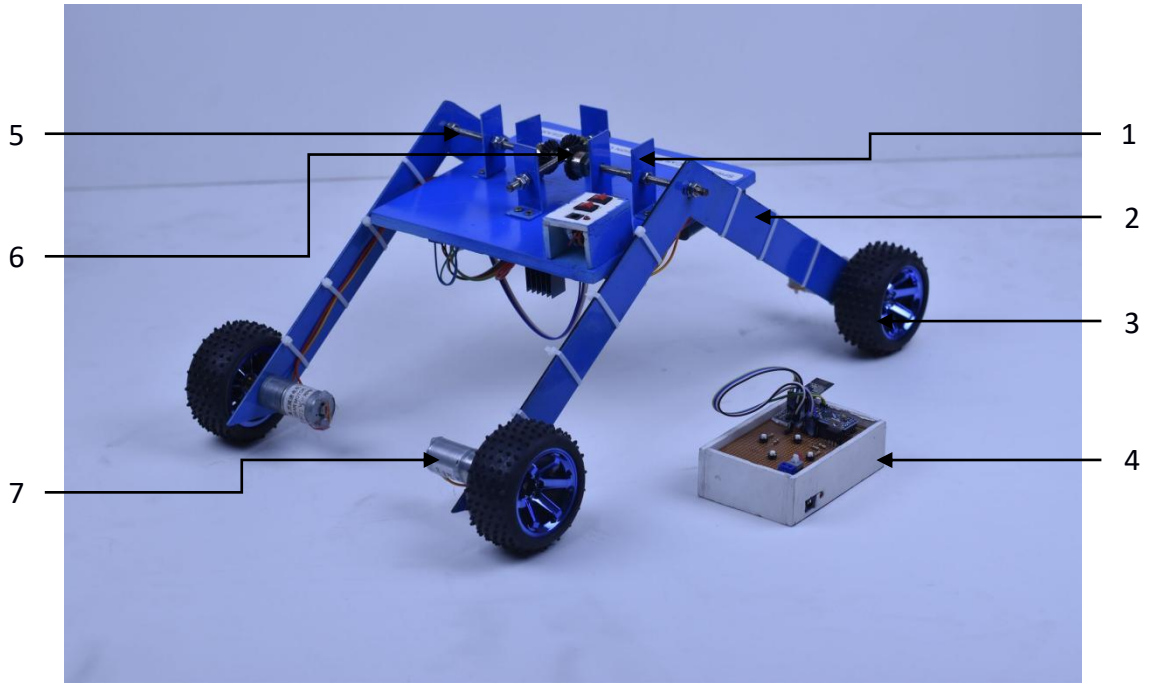

Figure 4.3: Ready Project Image with RF Controller

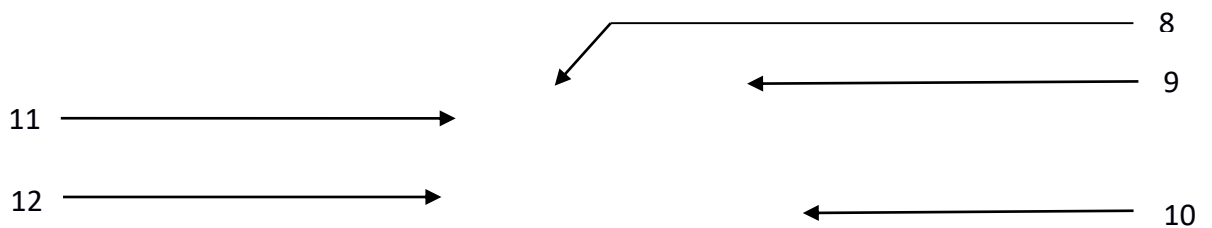
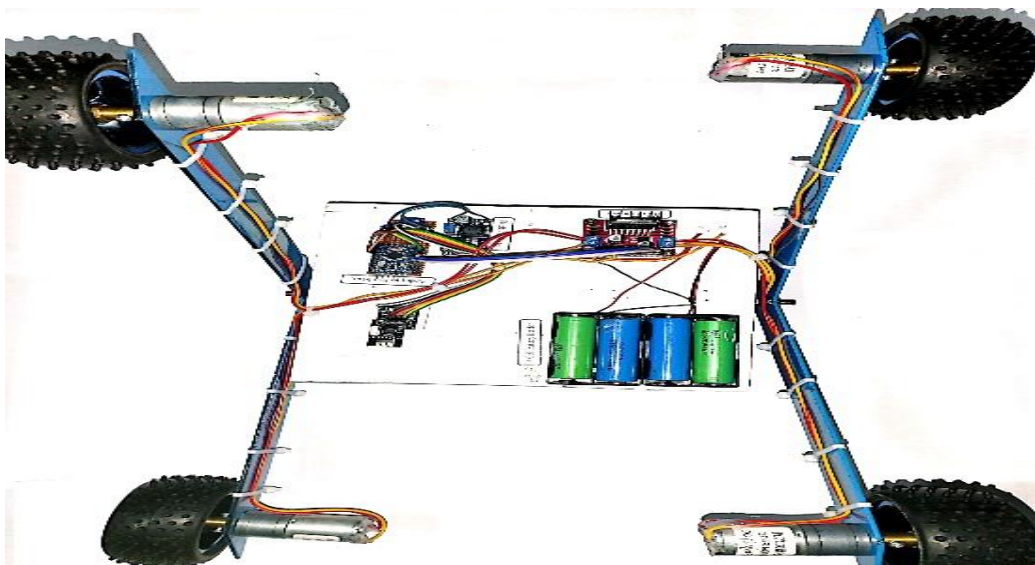

Figure 4.4: Power Supply System

4.3 Components List

1. L – Shaft
2. Frame
3. Wheel
4. Remote controller
5. Bold
6. Bevel Gear
7. Motor
8. Buck Converter
9. Motor Driver
10. Battery Cell
11. Arduino Pro Mini
12. Radio Frequency (RF)

CHAPTER 5

RESULTS AND DISCUSSION

5.1 Discussion

While working on our project, we did face some difficulties as it is a very complex system but the end results, we came up with were quite satisfactory. We have put the whole system through several tasks to validate our work and also have taken necessary notes for future

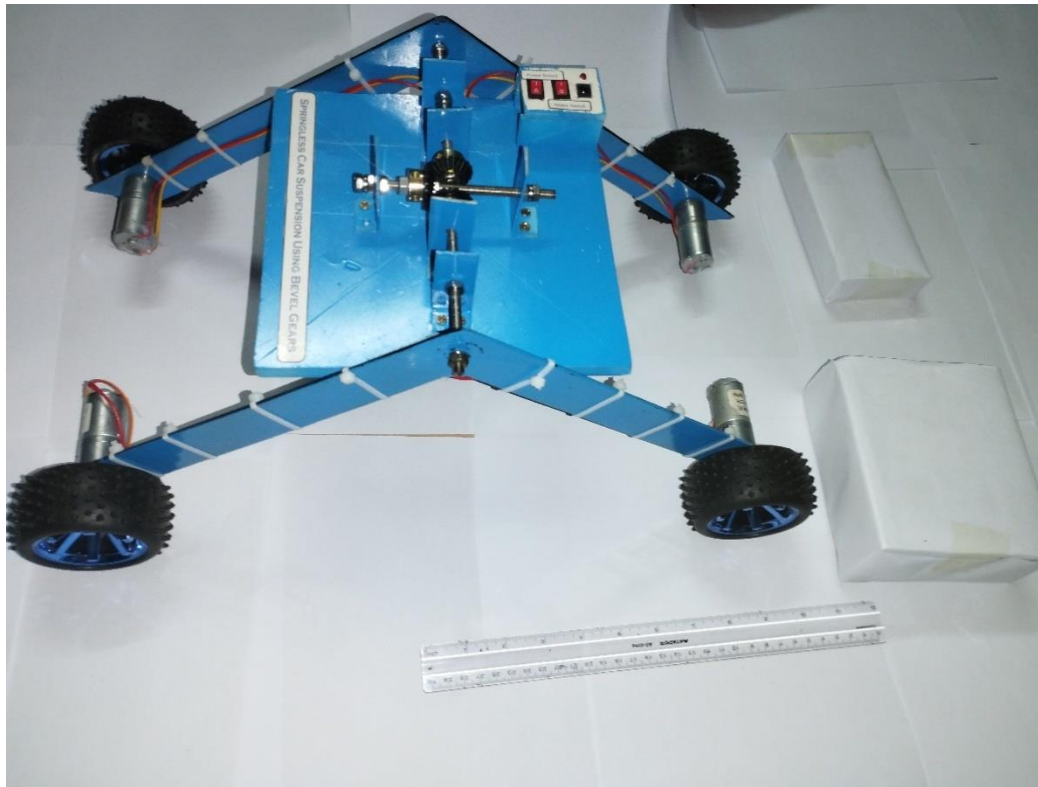

improvements. Some future recommendations that we have involves improvement in system design and wiring, adding features for more efficient.

5.2 Results

Now, it's time to talk about the results.

- When this project is power up then it is able to work.
- Then by RF controller button can move the vehicle easily.
- And this type of vehicle can move also in rough way.

ct- 01

← 30 mm

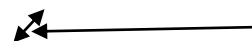

Object- 02

← 60 mm

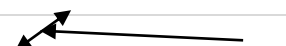

Figure 5.1: Project Is Before The Objects

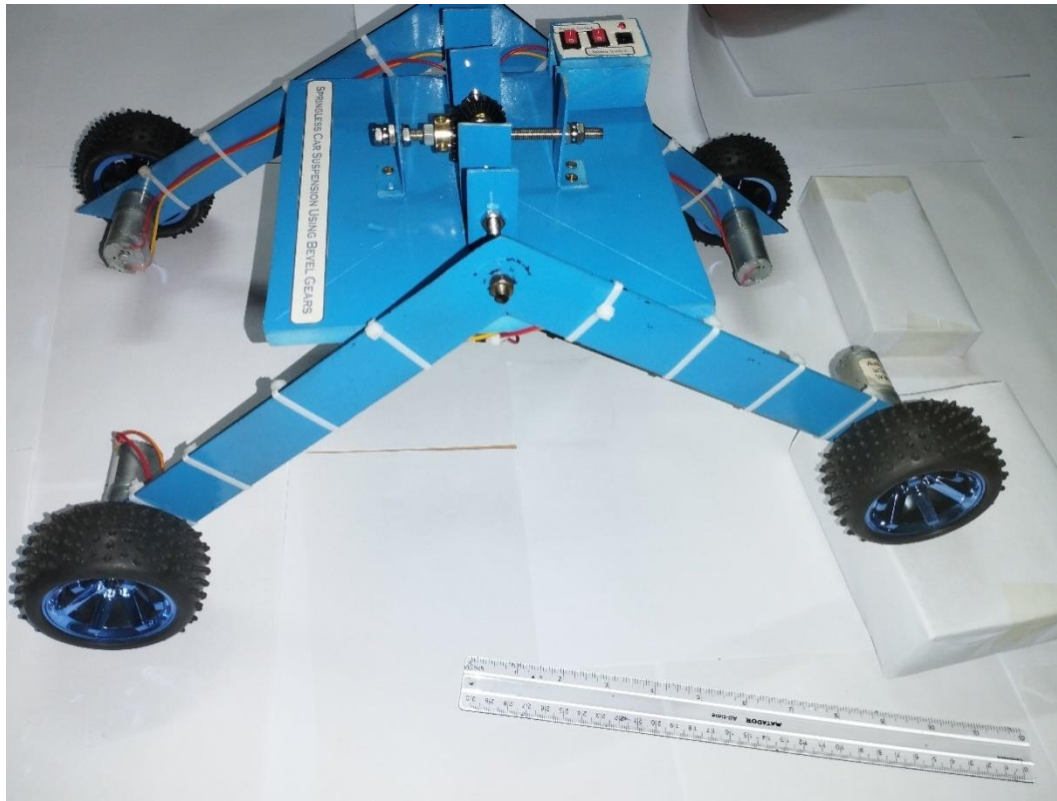

Figure 5.2: Project Is Moving Over The Object



Figure 5.3: Car Wheel and Bevel Gear with Dimension

5.3 Table of Data Analysis by Rectangular Object

SL No.	Object	Object length (mm)	Object Width (mm)	Diameter of Wheel (mm)	Diameter of Gears (mm)	Rotation of Gears (mm)
1	Rectangular	130	60	85	26.3	4
2		145	30			2
3		130	20			1

5.4 Advantages

There are many advantages of our project because of its accuracy. Some of the advantages are pointed out below:

- It is able to move in rough road in without hassle
- Bevel gear helps to move smoothly
- Car motion divided in two shaft which are at right angle.
- The vehicle arrangement is very compact
- Easy Mechanism and Construction.
- Speed can be increased.
- Comfort riding experience

5.5 Disadvantages

1. Our system is controlled by RF controller so it take time to operate
2. No extra power in this system. If battery discharge fully then the system will stop.

5.6 Applications

Springless suspension system made of bevel gears can be used in various applications where suspension is required. These can be include vehicles such as cars, trucks, and off-road vehicles, as well as industrial equipment and machinery. Bevel gears-based suspension system can provide a smooth, stable ride and can be designed to handle heavy loads and off-road conditions. They are also commonly used in robotics and automation where precision movement is required.

This project has applications in many fields due its necessity. We have selected a few of them and they are given below:

- Control the car properly in unlevel ground and hilly roads.
- Drives for high – torque and high speed applications.
- This system can use any kind of vehicle.

CHAPTER 6

CONCLUSION

6.1 Conclusion

This is a slashing technology that might be fitted in the car we drive every day. People learned about the methodology used to support this viewpoint, which makes it potentially interesting. The system is made for all kinds of vehicle mobility. This car with a bevel gear transmission can travel smoothly on both curved and straight roads.

6.2 Future Scope

We are thinking about adding many features to our project in the future to get more desirable out comes. Some of the steps that we are thinking about taking are given below:

- In future we will add some sensor to measure vehicle condition.
- In future we will add camera monitoring System to view area.
- In future we will add protection equipment to protect this system from any kind of hazard.

Reference

- [1] Chan W., Lee S.C., Hon A., Liu L., Li D., Zhu N., 2015, Management learning from air purifier tests in hotels: Experiment and action research, International journal of hospitality management, 44.
- [2] Hao Z.G., Su X.M., 2018, Determination and Distribution of Indoor Off-odor Pollutants, Chemical Engineering Transactions, 68.
- [3] Klepeis N.E., Bellettiere J., Hughes S.C., Nguyen B., Berardi V., Liles S., Hovell M.F., 2017, Fine particles in homes of predominantly low-income

- families with children and smokers: Key physical and behavioral determinants to inform indoor-air-quality interventions, *PloS one*, 12(5), e0177718, DOI: 10.1371/journal.pone.0177718
- [4] Oh H.J., Nam I.S., Yun H., Kim J., Yang J., Sohn J.R., 2014, Characterization of indoor air quality and efficiency of air purifier in childcare centers, Korea, *Building and Environment*, 82, 203-214, DOI: 10.1016/j.buildenv.2014.08.019
- [5] Park H.K., Cheng K.C., Tetteh A.O., Hildemann L.M., Nadeau K.C., 2017, Effectiveness of air purifier on health outcomes and indoor particles in homes of children with allergic diseases in Fresno, California: A pilot study, *Journal of Asthma*, 54(4), 341-346, DOI: 10.1080/02770903.2016.1218011
- [6] Rice J.L., Brigham E., Dineen R., Muqueeth S., O'keefe G., Regenold S., Diette G.B., 2018, The feasibility of an air purifier and secondhand smoke education intervention in homes of inner city pregnant women and infants living with a smoker, *Environmental research*, 160, 524-530, DOI: 10.1016/j.envres.2017.10.020
- [7] Shao D., Du Y., Liu S., Brunekreef B., Meliefste K., Zhao Q., Xu H., 2017, Cardiorespiratory responses of air filtration: A randomized crossover intervention trial in seniors living in Beijing: Beijing indoor air purifier study, *Science of the Total Environment*, 603, 541-549, DOI: 10.1016/j.scitotenv.2017.06.095
- [8] Wongaree M., Chiarakorn S., Chuangchote S., Sagawa T., 2016, Photocatalytic performance of electrospun CNT/TiO₂ nanofibers in a simulated air purifier under visible light irradiation, *Environmental Science and Pollution Research*, 23(21), 21395-21406, DOI: 10.1007/s11356-016-7348-z
- [9] Xiao R., Mo J., Zhang Y., Gao D., 2018, An in-situ thermally regenerated air purifier for indoor formaldehyde removal, *Indoor air*, 28(2), 266-275, DOI: 10.1111/ina.12441

