

# Bluetooth Operated Garage Door Opener

A thesis report submitted to the Department of Mechanical Engineering for the partial fulfillment of the degree of Bachelor of Science in Mechanical Engineering

A Thesis by

Safayet Hassan Khan

ID No: BME1901017176



Supervisor:

Nuruzzaman Rakib

Assistant Professor

DEPARTMENT of MECHANICAL ENGINEERING

SONARGAON UNIVERSITY (SU)

147/I, Green Road, Panthapath, Dhaka, Bangladesh

JANUARY 2023

# APPROVAL

This is to certify that the project on Bluetooth Operated Garage Door Opener

” by **Safayet Hassan Khan (ID No: BME1901017176)** has been carried out under our supervision. The project has been carried out in partial fulfillment of the requirements of the degree of Bachelor of Science (B.Sc.) in Mechanical Engineering in the year of 2023 and has been approved as to its style and contents.

.....

*Nuruzzaman Rakib*  
Assistant Professor  
Department of Mechanical  
Engineering  
Sonargaon University (SU)

# DECLARATION

We, hereby, declare that the work presented in this project is the outcome of the investigation and research work performed by us under the supervision of Nuruzzaman Rakib, Assistant Professor, Department of Mechanical Engineering, Sonargaon University (SU). We also declare that no part of this project and thesis has been or is being submitted elsewhere for the award of any degree.

Safayet Hassan Khan

ID No: BME1901017176

# ACKNOWLEDGEMENT

First of all, we are grateful to God, the Almighty for giving us the courage and enthusiasm to complete the thesis work. The authors express their gratitude to “**Nuruzzaman Rakib**” for his constant & meticulous supervision, valuable suggestion and encouragement to carry out this work. For all this, the authors acknowledge their sincere gratitude to him. We are also grateful to all our thesis & project working team of SU for their help in construction of the project work and give their valuable knowledge and time for completing the experiment. Finally, we would like to thank everybody who supported us in any respect for the completion of the thesis.

Authors

Safayet Hassan Khan

# Abstract

This dissertation will present a new method of controlling a garage door in a smart and more developed way. It will be focused on the software part of this project. It can be fully controlled autonomously through multiple control devices including control of humans by analog buttons and a mobile application, which is programmed fully by the developer. This project aims at enhancing the functionality of a garage door and make it more secure by inserting some sensors and actuators to ensure more safety of the overall method for this mechanical device.

The improvement of innovation is progressively. Exceptional and gives a great deal of comfort in the utilization of gadgets. Or instruments identified with human requirements. Considering this, the creator made an entryway regulator utilizing a Bluetooth signal from an. Android versatile. And a carport. Entryway regulator utilizing an Arduino-based. Metal finder. This examination depicts. Clients are not needed to get off the vehicle to open the entryway and carport. On the grounds that through a Bluetooth signal from an Android telephone, clients can open and close the carport. Door naturally and through discovery of metal sensors, the carport entryway can be opened and shut consequently. Without troubling. Individuals to open the carport. Bluetooth Classic (BT) remains the true network innovation in vehicle sound systems, remote headsets, workstations, and a plenty of wearables, particularly for applications that require high information rates, for example, sound streaming, voice calling, tying, and so on Dissimilar to in Bluetooth Low Energy (BLE)., The nonstop worldwide expansion in the quantity of vehicles has prompted an expansion in leaving issues, especially concerning the quest for accessible parking spots and discovering vehicles. In this paper, we propose a route framework for vehicle proprietors to discover their vehicles in indoor parking structures. The proposed framework includes a vehicle looking through portable application and a situating helping subsystem. The application guides vehicle proprietors to their vehicle's dependent on a "turn-by-turn". Route methodology and can address the clients. Going direction. The subsystem utilizes reference point innovation for indoor situating, supporting self-direction. of the vehicle looking through portable application. This investigation. Likewise planned a nearby facilitate framework.

# List of Contents

<b>APPROVAL .....</b>	<b>II</b>
<b>DECLARATION.....</b>	<b>III</b>
<b>ACKNOWLEDGEMENT .....</b>	<b>IV</b>
<b>ABSTRACT.....</b>	<b>IV</b>
<b>LIST OF CONTENTS.....</b>	<b>VI</b>
<b>LIST OF FIGURE .....</b>	<b>IX</b>
<b>CHAPTER-1.....</b>	<b>10</b>
<b>INTRODUCTION.....</b>	<b>10</b>
1.1 INTRODUCTION.....	10
1.2 PURPOSE AND SCOPE OF WORK .....	10
1.3 OBJECTIVE .....	11
1.4 SUMMARY .....	11
<b>CHAPTER-2.....</b>	<b>12</b>
<b>LITERATURE REVIEW .....</b>	<b>12</b>
2.1 LITERATURE REVIEW .....	12
2.2 ACCORDING TO SISWATI KUMAR .....	15
2.3 ACCORDING TO CHRISTOPHER K. PRINUS. ....	15
2.4 ACCORDING TO SANNER MAHMOOD.....	15
2.5 METHODOLOGY .....	16
<b>CHAPTER-3.....</b>	<b>17</b>
<b>DESIGN AND IMPLEMENTATIONS .....</b>	<b>17</b>
3.1 CIRCUIT DIAGRAM.....	17
3.2 BLOCK DIAGRAM.....	18

<b>CHAPTER-4.....</b>	<b>20</b>
<b>DESIGN AND IMPLEMENTATION.....</b>	<b>20</b>
4.1 INTRODUCTION.....	20
4.2 THE SPECIFICATIONS OF THE ARDUINO UNO.....	21
4.3 BLUETOOTH RECEIVER HC-05.....	21
4.4 TABLE SPECIFICATIONS OF HC-06.....	22
4.5 ANDROID APPLICATION AND MOBILE PHONE.....	23
4.6 PROGRAMMING THE ARDUINO.....	23
4.7 INTEGRATING THE BLUETOOTH MODULE TO ARDUINO.....	23
4.7 COMMUNICATION BETWEEN ANDROID PHONE AND THE APPLIANCES.....	24
4.9 HOW TO TEST THE CONNECTION.....	25
4.10 CONNECTING THE APPLIANCE TO THE ARDUINO BOARD.....	25
4.11 MAJOR COMPONENT EXPLANATION.....	26
4.12 DEFINING ARDUINO.....	26
4.13 ARDUINO ARCHITECTURE:.....	27
4.14 ARDUINO PIN DIAGRAM:.....	28
4.15HOW TO PROGRAM AN ARDUINO?.....	29
4.16 FIVE STEPS TO PROGRAM AN ARDUINO.....	30
4.17 A BASIC SKETCH CONSISTS OF 3 PARTS:.....	30
4.18 FEW OF BASIC ADRUINO FUNCTIONS ARE:.....	30
4.18 HOW TO DESIGN YOUR OWN ARDUINO?.....	31
4.19 SEVEN REASONS WHY ARDUINO IS BEING PREFERRED THESE DAYS.....	31
4.20 LCD (LIQUID CRYSTAL DISPLAY).....	32
4.21 PIN DESCRIPTION OF LCD:.....	33
4.22 BREAD BROAD:.....	34
4.23 ADAPTER (AC TO DC 12V):.....	34
4.24 LED LIGHT:.....	34
4.25 WORKING PRINCIPLE OF LED LIGHT:.....	35
4.26 BUZZER:.....	35
4.27 FEATURES OF BUZZER:.....	35

4.28 WORKING PRINCIPLE OF BUZZER: .....	36
4.29 APPLICATION OF BUZZER: .....	36
<b>CHAPTER 5 .....</b>	<b>37</b>
<b>RESULTS AND DISCUSSION .....</b>	<b>37</b>
5.1 RESULT .....	37
5.2 LIMITATIONS AND PROBLEMS ENCOUNTERED .....	37
5.3 ADVANTAGES.....	38
5.4 DISADVANTAGE .....	38
5.5 APPLICATIONS.....	38
5.6 PROJECT IMAGE.....	38
<b>CHAPTER 6 .....</b>	<b>39</b>
<b>CONCLUSION AND FUTURE WORKS .....</b>	<b>39</b>
6.1 INTRODUCTION.....	39
6.2 CONCLUSION.....	39
5.3 FUTURE WORKS .....	39
<b>REFERENCES.....</b>	<b>41</b>
<b>APPENDIX A .....</b>	<b>44</b>
CODE FOR ARDUINO .....	44



## List of Figure

Figure 3. 1 Circuit Diagram of Mechanical Garage Door Opener using Bluetooth .....	17
Figure 3. 2 Circuit Diagram of Mechanical Garage Door Opener using Bluetooth .....	18
Figure 4. 1 Hardware implementation. Arduino Nano .....	20
Figure 4. 2 Specifications of Arduino .....	21
Figure 4. 3 HC-05 and its various pins. ....	22
Figure 4. 4 Specifications of HC-06 .....	22
Figure 4. 5 Connection between Arduino and the Bluetooth Module .....	23
Figure 4. 6 Connection between the Bluetooth module and the Arduino.....	24
Figure 4. 7 Communication between Android Phone and the Appliances .....	25
Figure 4. 8 Arduino NANO .....	26
Figure 4. 9 Block Diagram of Arduino Architecture .....	27
Figure 4. 10 Pin Diagram of Arduino .....	28
Figure 4. 11 Program file of Arduino .....	29
Figure 4. 12 Liquid Crystal Display .....	32
Figure 4. 13 Connection diagram of LCD .....	33
Figure 4. 14 Pin Description of LCD.....	33
Figure 4. 15 Piezo Buzzer.....	35
Figure 5.1 <i>Project Real picture</i> .....	38

# Chapter 1

## Introduction

### 1.1 Introduction

Nowadays, almost all our lives have started being developed and worked on in order to improve on their functionality and overall performance, and digitization and controlling everything using computers has helped a great deal in making this goal easier. Computers managed to break the barriers of manual or human control to full on automatic, autonomous, and smart controls over entire projects without the need of being in the same country. This has allowed engineers to create different algorithms and programs in order to control the most complex machines and prevent them from fatal accidents and flaws that were harmful to the people using them or even around them. In our project, we present a new smart way to operate a garage door autonomously while taking in consideration the risks that are usually accompanied with garage doors and operating them. We have worked on ways to give people total control of the garage door with a click of a button as well as control over the risks of someone being in the way of the door and might be in danger of an accident with the door. This project introduced microcontrollers like the Arduino Uno microcontroller. [1] This central processing unit, along with other electronic components manages to provide order to all the actuators operating the garage door and authorize full control for users.

the Arduino Nano microcontroller uses an open-source software and requires specific C++ programming for the board on an integrated development unit called Arduino IDE. This entirety of the code is programmed on that IDE and sometimes it requires the inclusion of additional libraries that provide better control of the components connected to the Arduino.

### 1.2 Purpose and Scope of Work

This project aims at bettering the way a garage door functions and how computers and smart sensors and actuators can help improve its functions. In this dissertation, we will discuss how we managed to improve on the functionality using the coding and the types of algorithms used in order to control all the components and allow them to work together coherently as one unit to perform all the programmed

functions on the microcontroller. By perfecting the code for the Arduino to easily control all the components without any complication, we would have reached our main goal of the best software solution. The scope of our work starts with a small introduction, followed by the specification of the purpose of our work, afterwards, an overview of some existing solutions is provided and then a morphological chart explaining all the solution choices we picked. Furthermore, we start discussing our model and simulations, followed by the testing phase of the code. Finally, we finish with a conclusion that summarizes our work and provides reader with all the necessary information about the project. We then cite all the resources that we have gotten our information from and used in this dissertation about the software design if the smart garage door project.

### **1.3 Objective**

The main objectives of our project are given bellow,

- To the make an electromechanically control gate.
- Tp the make a Bluetooth control mechanical gate.
- To the design a low-cost electromechanical gate.
- To the learn about electromechanical controlling.
- To the learn about Bluetooth communication

### **1.4 summary**

The heart of these smart devices is microcontrollers. In other words, the microcontrollers are heavily used in embedded applications. As well as mobile phone, tablet and laptop, everybody has almost an intelligent device such under their hands, and they are basically created from hardware components like processor, ram/rom/flash memory/display/input-output ports. In this system, an operating system that controls the hardware is needed in order that the electronic card can work. The microcontrollers have the necessary structure so that we can simply prepare and control this operating system.

# Chapter 2

## Literature Review

### 2.1 Literature Review

Recently, studies have investigated the issue of pedestrian navigation. Typically, pedestrian navigation focuses on how to plan the guidance of the route to the destination effectively and efficiently. The solution to the navigation of car searching is like that of representative pedestrian navigation. For car searching, the following three tasks should be performed: positioning, route planning, and guidance information presentation. Positioning aims to identify the location of the pedestrian and parking space.

Route planning involves the determination of the route from the car owner's location to the parking space of the car. Given the planned route and environmental information (e.g., a map or floor plan), the presentation of guidance information physically shows the planned route and/or direction to the car owner, possibly in visual, audio, haptic, or hybrid forms.

The global positioning system (GPS) is a conventional and widely used approach for user localization. But may not be accurate for indoor environments because of the indoor shadowing effect. Prior studies have proposed feasible mechanisms for indoor positioning. The mechanisms use information and communication-based technologies, such as infrared, Wi-Fi, Bluetooth, and the vision-based method.

The micro-location technique based on beacon technology provides another localization technique in the indoor environment. Beacon technology operates over Bluetooth Low Energy (BLE), which is a wireless form of technology with low power and low cost and is presently considered as the primary form of wireless technology in mobile devices. As a result, beacon

technology is regarded as an appropriate indoor positioning solution, and a comprehensive survey of BLE-based indoor positioning mechanisms for smart phones was proposed in. Mobile devices have currently become prevalent. For human beings, and thus it is quite suitable for car owners to use a mobile device to obtain navigation information.

The majority of the existing approaches utilize the whole map along with the determined route as the output modality of navigation information. However, the whole map may include unnecessary information for users, therefore increasing their burden.

When walking toward their destinations. To solve this problem, previous studies have introduced an intuitive navigation. Scheme known as turn by-turn navigation. The main concept of the scheme is to provide users with the necessary navigation. Information, such as directions with the distance and time to turn based on the physical world.

The paper proposes a BLE-based pedestrian. Navigation system, called BLE-PNS, for car searching in indoor parking garages. As car owners search for their own cars and walk toward the spaces where their cars are parked, this paper uses the term “pedestrian”. To represent the term “car owner” hereafter.

The main concept of BLE-PNS includes self-guiding and effortless navigation. Self-guiding indicates that pedestrians. Obtain the navigation information according to their mobile devices instead of the facilities of parking garages, e.g., liquid-crystal display (LCD) or light emitting diode (LED) display boards). Effortless navigation implies that the proposed system provides intuitive and accurate navigation information to pedestrians.

Recall that the GPS coordinates (i.e., latitude and longitude) are inappropriate for indoor positioning. Thus, in BLE-PNS, we deployed numerous location-aware devices, called anchors, to assist pedestrians to determine their locations, and introduced a local coordinate system to identify the locations of parking spaces and anchors. In addition, BLEPNS uses the “walk-straight-first” strategy to derive the shortest route with the minimum number of changing directions (i.e., turning left or right) at intersections as the optimal guidance route.

With respect to navigation information provision, the proposed BLE-PNS considers the “turn-by-turn” navigation information rather than the map of the whole parking garage with a thorough guidance route for pedestrians.

The turn-by-turn strategy is defined as a navigation scheme which only provides users with the guidance indication of the walking direction at the next intersection. Specifically, in our navigation strategy, if a pedestrian does not approach the parking space of the parked car, the mobile device provides an indication with respect to the walking direction (walk straight, turn right, or turn left) at the

next intersection. Otherwise, the mobile device provides the local map and emphasizes. The parking space where the pedestrian.

Has parked his/her car. The BLE-PNS. Also proposes an orientation correction scheme to avoid the misunderstanding of navigation. Information resulting from the “might-mill-around-and-get-off course” movement of pedestrians. The scheme provides an instant hint to the pedestrian when the pedestrian’s heading orientation does not conform to the indicated direction.

Derived from the proposed system. In this study, we considered the parking lot in the campus of Minchin University of Science and Technology as the testing field and conducted a series of field trials to evaluate.

The performance of the proposed system. We implemented the prototype of the proposed system, which deploys enough anchors in the predetermined locations of the field and develops the car-searching. Mobile app running on an Android-based smartphone. The anchor’s location is represented by a pair of the coordinates. of the proposed local coordinate system. The anchors use the BLE technology to communicate with the pedestrian’s smartphone.

The field test results showed that the proposed BLE-based pedestrian. Navigation system can correctly identify the location of the pedestrian. Moreover, the pedestrian can not only obtain the correct route guidance information. When walking toward the space of the parked car but also receive instant indication when the pedestrian’s heading orientation.

Is incorrect. We also evaluated the performance of the proposed route planning scheme. Simulation results validated that the proposed route planning scheme outperforms. The traditional Dijkstra’s algorithm in the number of changing directions. The rest of this paper is organized. As follows.

Section 2 formulates the system model and gives an overview of the proposed system. Section 3 elaborates. The design and implementation of the proposed BLE-based pedestrian navigation system. Section 4 shows the field testing. And simulation results. Section 5 provides concluding remarks.

## **2.2 According to siSwati Kumar**

The goal of their project was to make a modification to the garage door in order to reduce human effort while the opening and closing were also increasing the safety of garage. They were designing a door modification which could also applied to several door that were sliding and rolling in nature. For security purpose, they were considering swiping of a card or fingerprint scanning which makes their project secure but a bit costly because these security systems are pre made and thus they are not cheap

## **2.3 According to Christopher K. Prinus.**

In their project they designed a low-cost automatic gate with a proper secure system. The aim of their project was to show simply how an automatic door works. They used remote to open and close the garage door with IR sensors, they did not provide the system which opens automatically when car is near the garage door. This could have made the system advanced

## **2.4 According to Sanner Mahmood**

They designed the project which was capable to reduce human efforts and provided 3 ways to open the garage

1. Using IR sensors
2. Using Bluetooth
3. by a switch

They designed a system which could turn off the light or garage automatically after 60 seconds from any last order. The security that they were providing is not sufficient because they were not providing a series of pre-defined buttons to open the gate, they were only providing a single button to open it. Thus, a unknown person can easily open the garage door if he got the remote.

## 2.5 METHODOLOGY

In our project we are designing automatic garage door by using sensors and to ensure proper working we are providing an authenticate electrical system. We are also providing a special feature in our system in which the garage door automatically opens when the car will come near to it. In this feature, the door will open only for a particular car. We are using an IR transmitter to transmit the signal and an IR receiver to receive the signal. The signal carries out a binary code which is unique. We will attach this transmitter to the car. After receiving signal, authenticity of the code will be processed to check. To open and close the gate, there is also a remote which works on the same principle of IR sensors, we have to press a series of fix buttons in order to open the gate and a signal button to close it. Each button of remote have its own binary codes, when we press a series of buttons the microcontroller will check whether the series of codes are defined in our Arduino program or not and will open and close the gate accordingly. We use Arduino Uno as a microcontroller board based on AT mega 328P(datasheet). It has 14 digital pins, of which 6 can be used as PWM outputs ,6 as analog input, we can feed the command in Arduino uno with the help of IDE. In IDE programming we will allow only those certain binary codes to open the gate which are generated by IR sensors that we are using in our designing. In this way we can provide a secure automatic mechanical door opener. We will also mount IR obstacle avoidance sensor to the garage door to prevent closing of it while car is in the middle of the door. Now to open the gate we have a 12V DC motor which provides a normal torque of 2.5N-m, when microcontroller transmits the signal to open the door, current will flow in motor and when signal is to close the door, the current will be flowing in opposite direction A 12V DC supply is given to the motor and Arduino Uno. Arduino Uno converts this voltage to its operating voltage i.e., 5V and thus IR sensors have a supply of 5V. The potential is used to provide a rotational motion to the pinion via motor which is then converted into translational motion with the help of rack. Our door is clamped with this arrangement; thus, it will also slide as rotation of motor takes place. Once the door is fully open the motor will stop and the door will remain at open position until another signal will be sent. In the final (opening and closing) positions we have placed a sensor which will break the circuit as the door will reach to the end. (In opening) and start (in closing). Thus, motor stops running and our door will remain stop at the end position.



# Chapter 3

## Design and Implementations

### 3.1 Circuit Diagram

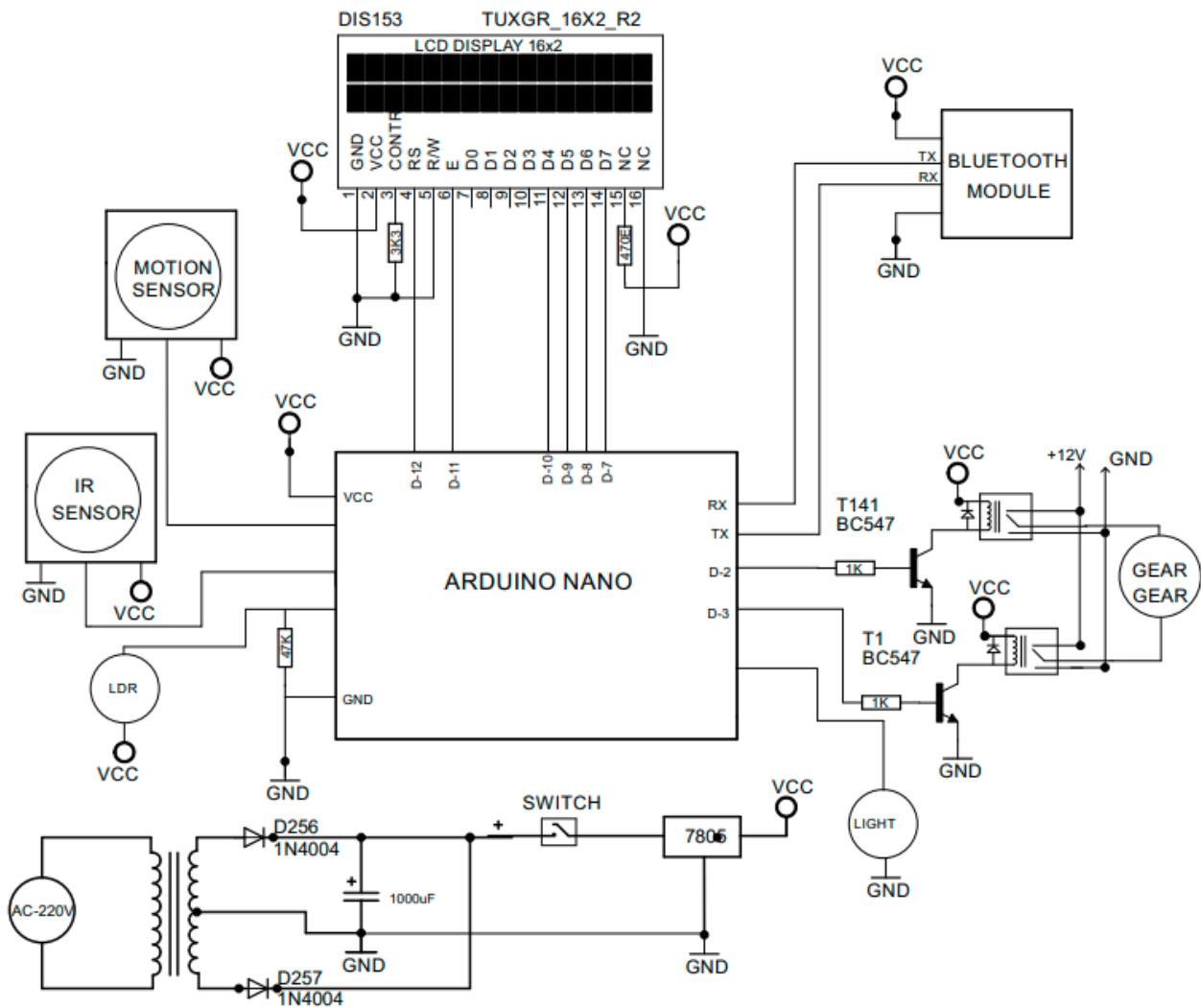

Figure 3. 1 Circuit Diagram of Bluetooth Operated Garage Door Opener

### 3.2 Block Diagram

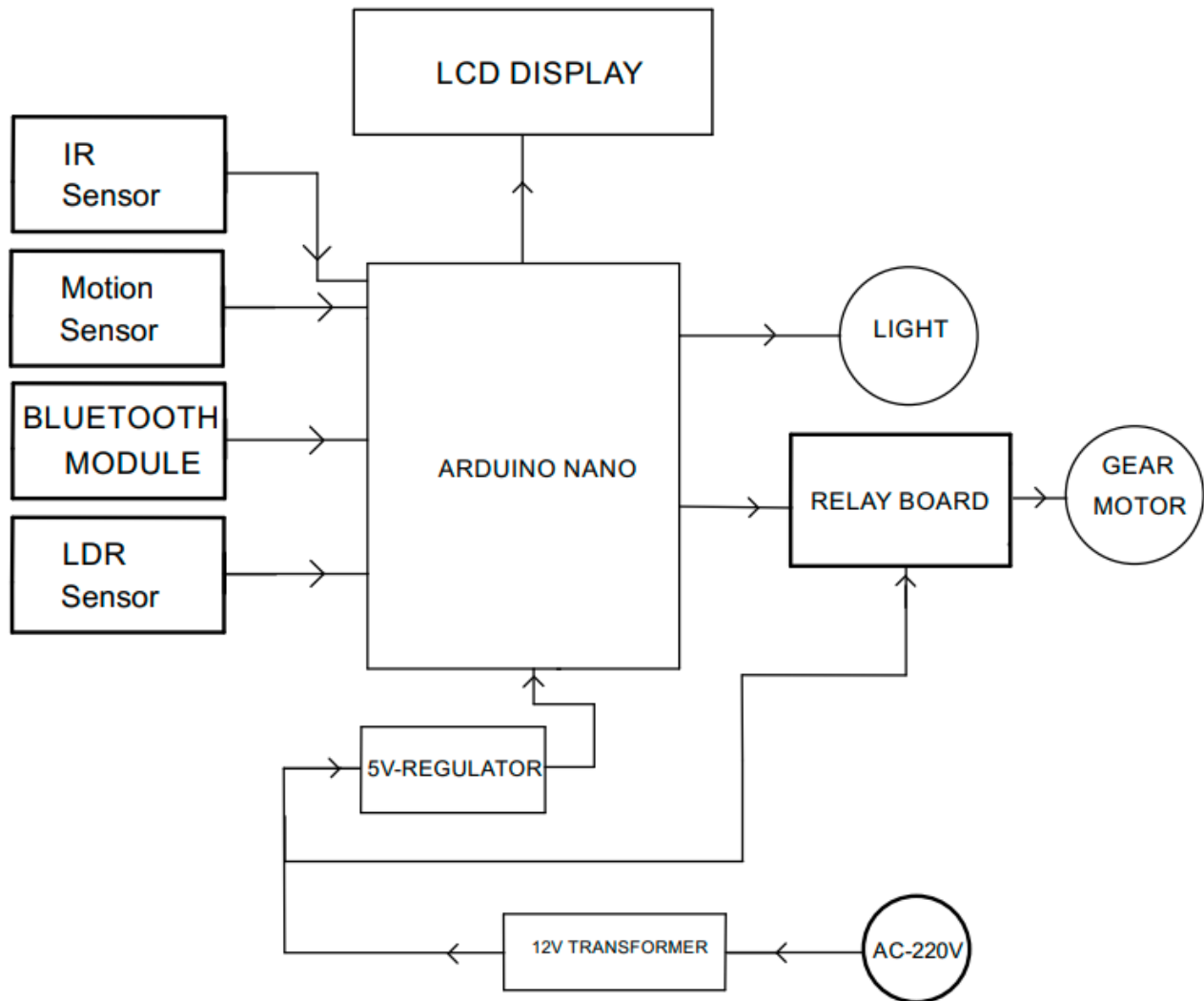

Figure 3. 2 Circuit Diagram of Mechanical Garage Door Opener using Bluetooth

### 3.3 Working Principle

In this early flood detection project, we use an ARDUINO, LCD display, Bluetooth module, Step-Down transformer, 5v DC water pump, motion sensor, 12v relay, 12v step down transformer, buzzer and some other necessary equipment. Step-down transformer converts 220v ac to 12v ac. We used 2 diodes for rectify and 1000uf capacitor for filtrating. 3.7v 3 battery are connect to series. This battery charged from this rectifier and filtered dc voltage. We use 1708 linier voltage regulator for 12v to 5 regulation that call VCC. Center tape transformer middle terminal connect to capacitor negative terminal and battery negative terminal that called GND.in this project we use as a programmable microcontroller. Here our all sensor and output device connect to Arduino's analog and digital input/output pin. We also use a Bluetooth module for commination system That's why we can call this project "Electromechanical based Gurage door opening system". In this project motion sensor connect to Arduino A0 pin, LDR sensors connect to A1, pin. motor control relay connects to pin no D2 and D3. And security light also connects to D3 pin. For Bluetooth module we choose TX and RX pin, Bluetooth TX pin connect to Arduino RX pin and Bluetooth RX pin connect to Arduino TX pin. And LCD 6 data pin connect to Arduino D12, D11, D10, D9, D8, D7 pin. When we send command "gate open" using Bluetooth app then turn on motor and gate open slowly. And when we send command "gate close" using Bluetooth app then turn on motor and gate close slowly. When motion sensor detects any motion then then system generate thief detection alarm.

# Chapter 4

## Design and Implementation

### 4.1 Introduction

This section describes the overall hardware needed to design this project. The system is designed using the Arduino Uno Board, the Bluetooth module (HC-06), optocouplers, an Android mobile phone, and an Android application to control the Arduino board as shown in It also uses various electronic components involved.

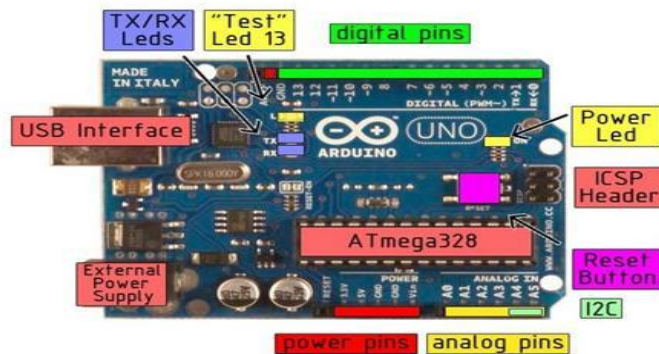

Figure 4. 1 Hardware implementation. Arduino Nano

Arduino Uno is a microcontroller board based on the Atmega 328. It has a ceramic resonator that is 16MHz, fourteen digital input/output pins (six of which can be used as PWM outputs), a reset button, a USB connection, a power jack and six analog inputs. It is an 8-bit microcontroller based on RISC architecture. The Arduino Uno board is shown in figure 8 with the parts labeled.

## 4.2 The specifications of the Arduino Uno.

Microcontroller	Atmega 328
Operating Voltage	5V
Input Voltage (Recommended)	7-12V
Input Voltage Limitation	6-12V
Digital Input/Output Pins	14
Analog Input Pins	6
Clock Speed	16MH z
EEPROM	1KB

*Figure 4. 2 Specifications of Arduino*

The recommended voltage is between 7-12V because if the voltage dips below 7V, the 5V pin on the Arduino board will become unstable and if the voltage rises above 12V, the board may overheat and become damaged. The Arduino does not use a RC oscillator, but rather a crystal oscillator because of the quality factor (Q). The quality factor for a crystal oscillator is of the order 100,000 whereas the quality factor for an RC oscillator is of the order 100. A quality factor is defined as:

$$Q = f/BW$$

Where f is the resonant frequency and BW is the bandwidth.

## 4.3 Bluetooth Receiver HC-05

A Bluetooth receiver HC 06 is used to receive signal from an Android phone. The benefit of using a Bluetooth module is that it only acts as a slave. The communication of voice and data over a wireless network, which is also known as Wireless Personal Area Network (WPAN) and works on a 2.4GHz band, gives the simplicity of communication with a mobile device under the same protocol. This

Bluetooth module has a range of 10m to 30m and can work at 3.3V or 5V giving it an advantage compared to other Bluetooth modules. This Bluetooth module can be used on projects that require low power. The state

pin in HC-06 will determine whether the module will work as a master or slave. RXD, TXD, VCC and GND pins of the Bluetooth module will be connected to the respective pins of the Arduino Uno.



Figure 4. 3 HC-05 and its various pins.

#### 4.4 TABLE Specifications of HC-06

Working Temperature	-20~+75 Centigrade
Mode of Operation	Slave
Default Baud Rate	9600
Default Pin Code	1234
Security Features	Authentication and Encryption
Frequency	2.4GHz ISM Band
Port	Serial Port

Figure 4. 4 Specifications of HC-06

## **4.5 Android Application and Mobile Phone**

The Android mobile phone used for this Project is Google Nexus 5 with an installed application called LMBT.

The LMBT application is a simple application on Android and is used to control the pins of the Arduino-Uno from an Android phone in a wireless manner. A simple Android user interface is employed by LMBT to control digital pins of Arduino Uno and PWM pins, to send commands to Arduino Uno in the form of text and reception of data over a Bluetooth serial module from Arduino.

## **4.6 Programming the Arduino**

The Arduino-Uno board needs to be programmed with a code so that it is able to interact with the application. Arduino provides a flexible platform, which helps to write a code for any function to be performed by the Arduino Uno and upload to the board.

APPENDIX A shows the full source code of the Arduino Uno. Interfacing the Atmega 328 with Electrically Erasable Programmable Read Only Memory (EEPROM) is done using the Universal Synchronous Asynchronous Receiver Transmitter (USART) protocol. The code is written in Embedded C using Atmel studio 6.0. The code is then compiled and converted to HEX code. Afterwards, the HEX code is then burned to the Atmega 328 microcontroller.

**4.7 Integrating the Bluetooth Module to Arduino**

For the Arduino Uno to be controlled, a connection is required between the Bluetooth module and the Arduino Uno.

The VCC port on the Arduino Uno board is connected to the VCC pin on the Bluetooth module (HC-06). The GND port on the Arduino Uno is connected to the GND pin on the Bluetooth module (HC-06). Finally, the transmitter of the Bluetooth module is connected to the receiver of the Arduino Uno as well as the transmitter of the Arduino Uno to the receiver of the Bluetooth module need to be connected. Table 3 shows the connection between the Arduino Uno and the Bluetooth module.

Arduino Uno Board	Bluetooth Module
GND port	GND pin
VCC port	VCC pin
Transmitter Pin	Receiver Port
Receiver Pin	Transmitter Port

*Figure 4. 5 Connection between Arduino and the Bluetooth Module*



The connection between the Arduino Uno and the Bluetooth module is the fundamental connection in the circuit Connection between the Bluetooth Module and Arduino Uno

Shows the connection between the Bluetooth module and the Arduino Uno.

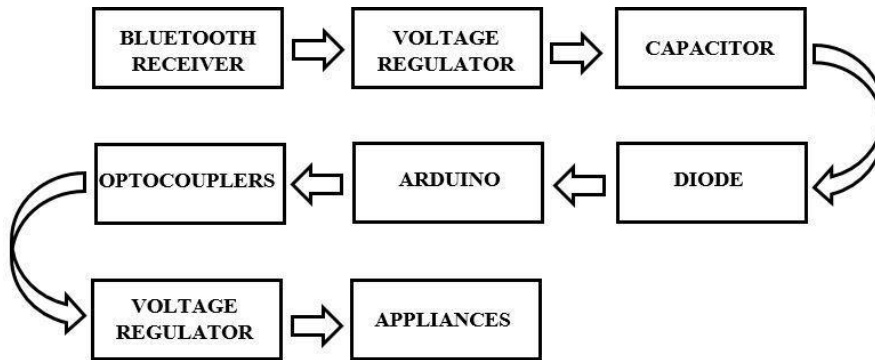

Figure 4. 6 Connection between the Bluetooth module and the Arduino.

The Bluetooth receiver transfers the signal to the voltage regulator, which then regulates the voltage and forwards it to the capacitor. Two capacitors are used in this circuit. One capacitor is of 1000 microfarad for appliances, that requires high power to operate and the other is of 10 microfarads, which requires low power to operate. The signal from the capacitor goes to the diode that restricts the flow of current to one side and allows the current to flow only in a single direction. The Arduino board then receives the signal from the diode, which goes to the opt couplers. Afterwards, the optocoupler is connected to the voltage regulator before being connected to the appliances. This connection is due to the opt coupler having a maximum power of 9000 watts, which if directly connected to the appliances may cause damage. The opt coupler is connected to a voltage regulator that regulates the voltage and drives the appliances.

#### 4.7 Communication Between Android Phone and the Appliances

The application on a mobile phone is coded with an integer value of 49, 50, 51, 52, 53, 54, 55, and 56. After opening the application, 1 and 49 are pressed and converted to the binary Value as well as sent to the receiver of the Bluetooth module (HC-05) via the Bluetooth on a cell phone. The binary value from the Bluetooth module goes to the Arduino. Arduino checks in its database

the equivalent of the binary code. If it is HIGH, the light should be turned ON and if it is LOW, the light should be turned OFF.

The block diagram in Figure 11 explains the steps needed to establish the connection.

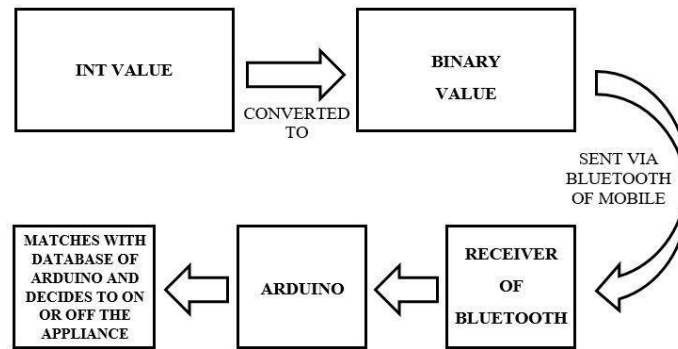

*Figure 4. 7 Communication between Android Phone and the Appliances*

## 4.9 How to Test the Connection

After the application is installed on the mobile phone and the Bluetooth module is connected to the Arduino Uno, the connection is to be tested to make sure that the phone is interacting with the Arduino Uno via the Bluetooth module (HC-06).

The steps to test the connection are as follows:

Open the application installed on the mobile phone.

With the help of the application, search for the Bluetooth devices.

Connect to the Bluetooth module (HC-06).

If the blinking of the light stops in the Bluetooth module, then it is working correctly, and the connection is established. If the light continues to blink, the connection needs to be checked.

## 4.10 Connecting the Appliance to the Arduino Board

After all the connections are done, the home appliances should be connected to the Arduino.

The positive end of the home appliance has to be connected to the anode port of the optocoupler and negative end of the appliance has to be connected to the power source using wires.

Using different optocouplers and Arduino ports, the connections is made for other appliances. Finally, with the help of a Bluetooth connected Android phone, all of the appliances in the house are controlled wirelessly.

#### **4.11 Major Component Explanation**

#### **4.12 Defining Arduino**

An Arduino is actually a microcontroller-based kit which can be either used directly by purchasing from the vendor or can be made at home using the components, owing to its open-source hardware feature. It is basically used in communications and in controlling or operating many devices. It was founded by Massimo Banzi and David Cuartielles in 2005.

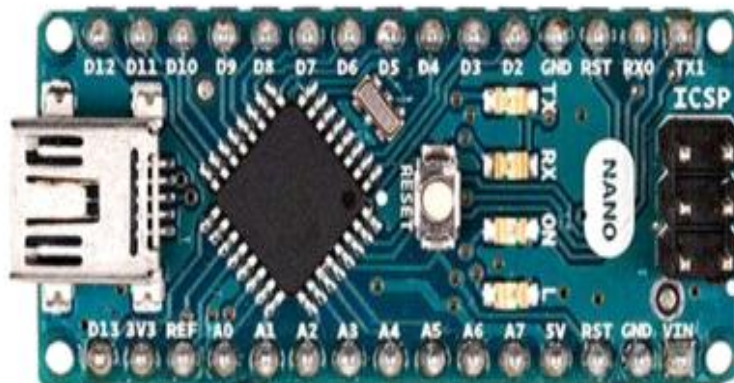

*Figure 4. 8 Arduino NANO*

### 4.13 Arduino Architecture:

Arduino's processor basically uses the Harvard architecture where the program code and program data have separate memory. It consists of two memories- Program memory and the data memory. The code is stored in the flash program memory, whereas the data is stored in the data memory. The code is stored in the flash program memory, whereas the data is stored in the data memory. The Atmega328 has 32 KB of flash memory for storing code (of which 0.5 KB is used for the bootloader), 2 KB of SRAM and 1 KB of EEPROM and operates with a clock speed of 16MHz.

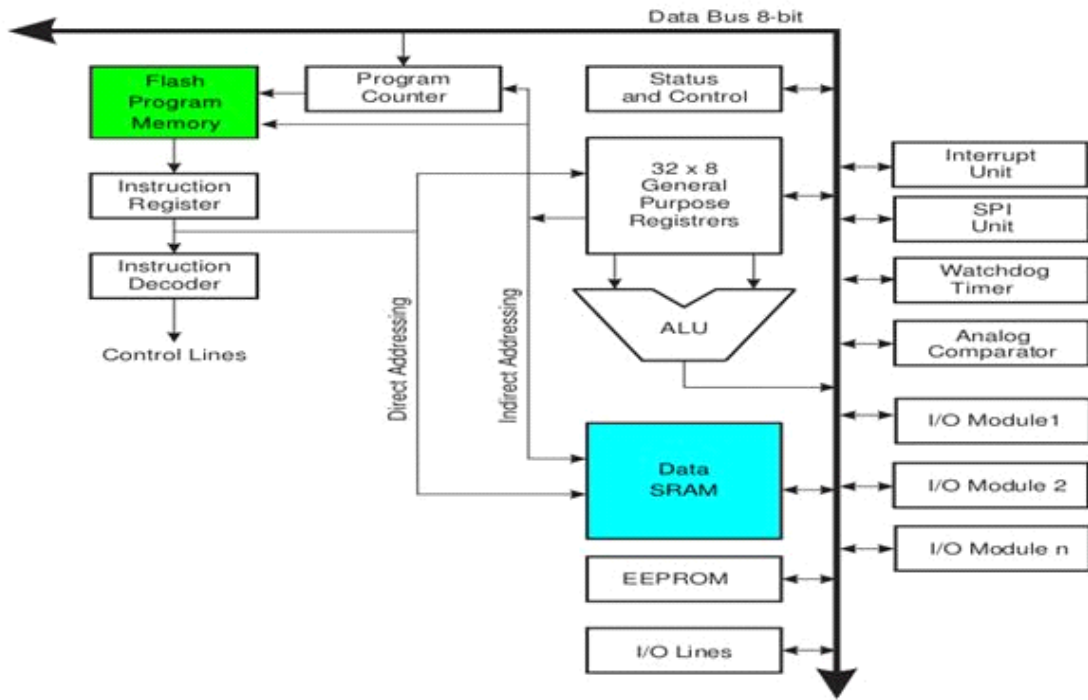
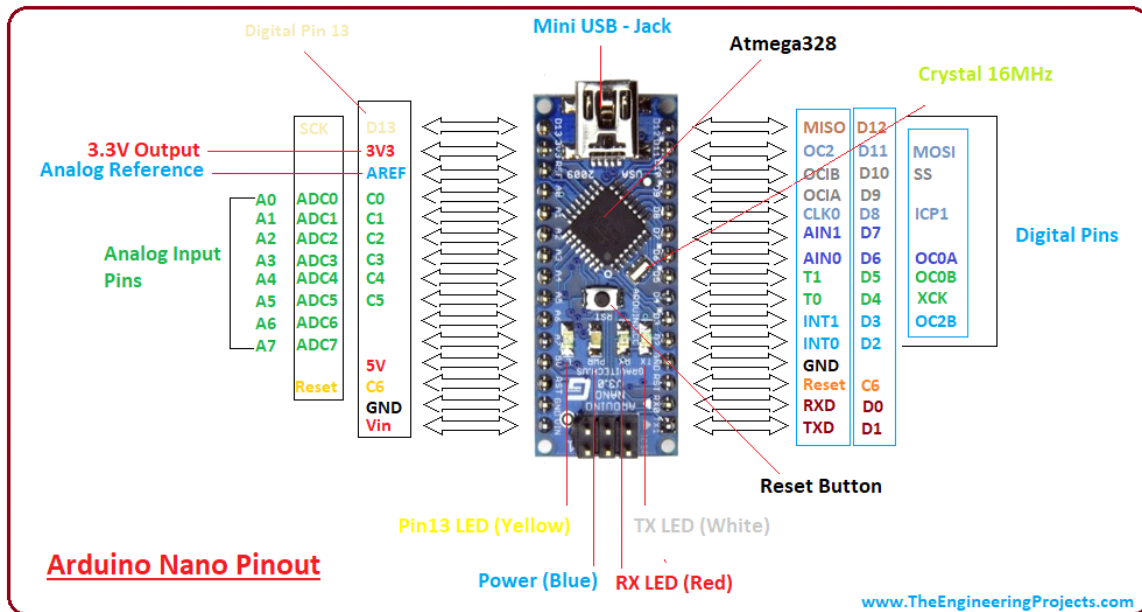

Figure 4. 9 Block Diagram of Arduino Architecture

## 4.14 Arduino Pin Diagram:

A typical example of Arduino board is Arduino Uno. It consists of ATmega328- a 28 pin



microcontrollers.

Figure 4. 10 Pin Diagram of Arduino

**Power Jack:** Arduino can be power either from the pc through a USB or through external source like adaptor or a battery. It can operate on an external supply of 7 to 12V. Power can be applied externally through the pin Vin or by giving voltage reference through the IORef pin.

**Digital Inputs:** It consists of 14 digital inputs/output pins, each of which provide or take up 40mA current. Some of them have special functions like pins 0 and 1, which act as Rx and Tx respectively, for serial communication, pins 2 and 3-which are external interrupts, pins 3,5,6,9,11 which provides pwm output and pin 13 where LED is connected.

**Analog inputs:** It has 6 analog input/output pins, each providing a resolution of 10 bits.

**ARef:** It provides reference to the analog inputs

**Reset:** It resets the microcontroller when low.

## 4.15 How to program an Arduino?

The most important advantage with Arduino is the programs can be directly loaded to the device without requiring any hardware programmer to burn the program.

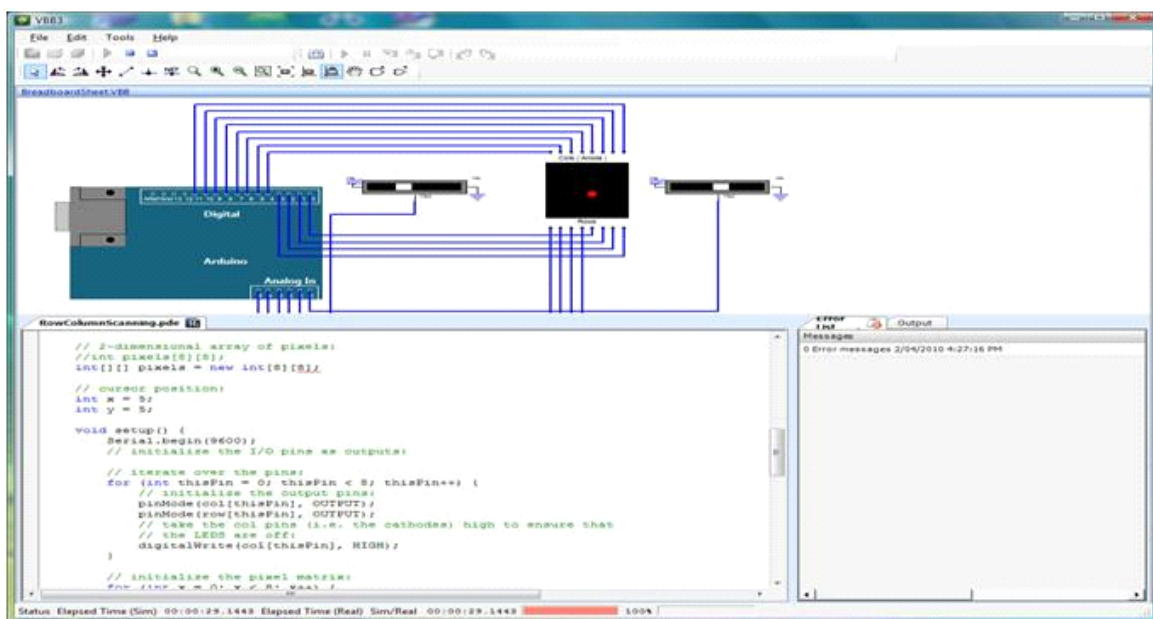

Figure 4. 11 Program file of Arduino

This is done because of the presence of the 0.5KB of Bootloader which allows the program to be burned into the circuit. All we have to do is to download the Arduino software and writing the code.

The Arduino tool window consists of the toolbar with the buttons like verify, upload, new, open, save, serial monitor. It also consists of a text editor to write the code, a message area which displays the feedback like showing the errors, the text console which displays the output and a series of menus like the File, Edit, and Tools.

#### **4.16 Five Steps to program an Arduino**

1. Programs written in Arduino are known as sketches.
2. The sketch is saved with .ino extension. Any operations like verifying, opening a sketch, saving a sketch can be done using the buttons on the toolbar or using the tool menu.
3. The sketch should be stored in the sketchbook directory
4. Chose the proper board from the tool's menu and the serial port numbers.
5. Click on the upload button or chose upload from the tool's menu. Thus, the code is uploaded by the boot loader onto the microcontroller.

#### **4.17 A basic sketch consists of 3 parts:**

1. Declaration of Variables
2. Initialization: It is written in the setup () function.
3. Control code: It is written in the loop () function.

#### **4.18 Few of basic Arduino functions are:**

1. **digitalRead**(pin): Reads the digital value at the given pin.
2. **digitalWrite**(pin, value): Writes the digital value to the given pin.
3. **pinMode**(pin, mode): Sets the pin to input or output mode.
4. **analogRead**(pin): Reads and returns the value.
5. **analogWrite**(pin, value): Writes the value to that pin.
6. **serial.begin**(baud rate): Sets the beginning of serial communication by setting the bit rate.

## **4.18 How to Design your own Arduino?**

We can also design our own Arduino by following the schematic given by the Arduino vendor and also available at the websites. All we need are the following components- A breadboard, a led, a power jack, a IC socket, a microcontroller, few resistors, 2 regulators, 2 capacitors. **The procedure as follows:**

1. The IC socket and the power jack are mounted on the board.
2. Add the 5v and 3.3v regulator circuits using the combinations of regulators and capacitors.
3. Add proper power connections to the microcontroller pins.
4. Connect the reset pin of the IC socket to a 10K resistor.
5. Connect the crystal oscillators to pins 9 and 10
6. Connect the led to the appropriate pin.
7. Mount the female headers onto the board and connect them to the respective pins on the chip.
8. Mount the row of 6 male headers, which can be used as an alternative to upload programs.
9. Upload the program on the Microcontroller of the readymade Arduino and then pry it off and place back on the user kit.

## **4.19 Seven Reasons why Arduino is being preferred these days**

1. It is inexpensive
2. It comes with an open-source hardware feature which enables users to develop their own kit using already available one as a reference source.
3. The Arduino software is compatible with all types of operating systems like Windows, Linux, and Macintosh etc.
4. It also comes with open-source software feature which enables experienced software developers to use the Arduino code to merge with the existing programming language libraries and can be extended and modified.
5. It is easy to use for beginners.
6. We can develop an Arduino based project which can be completely stand alone or projects which involve direct communication with the software loaded in the computer.
7. It comes with an easy provision of connecting with the CPU of the computer using serial communication over USB as it contains built in power and reset circuitry.



## 4.20 LCD (Liquid Crystal Display)

LCD (Liquid Crystal Display) screen is an electronic display module and find a wide range of applications. A 16x2 LCD display is very basic module and is very commonly used in various devices and circuits. It is available in a 16-pin package with back light, contrast adjustment function and each dot matrix have 5x8 dot resolution.

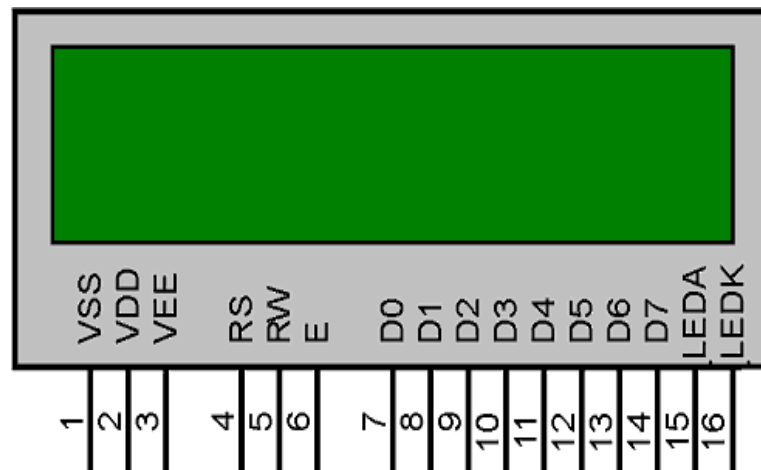

Figure 4. 12 Liquid Crystal Display

A **16x2 LCD** means it can display 16 characters per line and there are 2 such lines. In this LCD each character is displayed in 5x7 pixel matrix. This LCD has two registers, namely, Command and Data. The command register stores the command instructions given to the LCD. A command is an instruction given to LCD to do a predefined task like initializing it, clearing its screen, setting the cursor position, controlling display etc. The data register stores the data to be displayed on the LCD. The data is the ASCII value of the character to be displayed on the LCD. Click to learn more about internal structure of an LCD

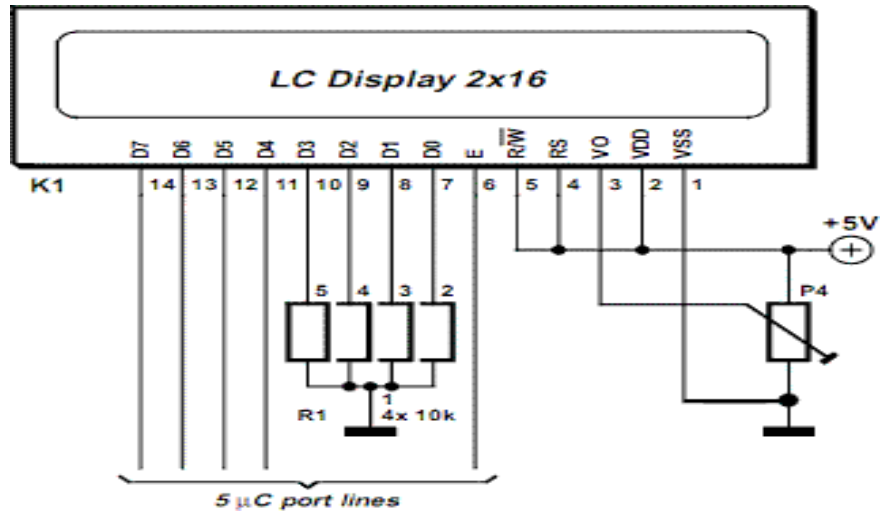

Figure 4. 13 Connection diagram of LCD

#### 4.21 Pin Description of LCD:

Pin No	Function	Name
1	Ground(0V)	Ground
2	Supply voltage; 5V (4.7V – 5.3V)	V <sub>cc</sub>
3	Contrast adjustment; through a variable resistor	V <sub>EE</sub>
4	Selects command register when low; and data register	Register
5	Low to write to the register; High to read from the register	Read/write
6	Sends data to data pins when a high to low pulse is given	Enable
7	8-bit data pins	DB0
8		DB1
9		DB2
10		DB3
11		DB4

Figure 4. 14 Pin Description of LCD

## **4.22 Bread Board:**

A breadboard is a construction base for prototyping of electronics. Originally the word referred to a literal bread board, a polished piece of wood used for slicing bread. In the 1970s the solder less breadboard (a.k.a. plug board, a terminal array board) became available and nowadays the term "breadboard" is commonly used to refer to these.

Because the solder less breadboard does not require soldering, it is reusable. This makes it easy to use for creating temporary prototypes and experimenting with circuit design. For this reason, solder less breadboards are also popular with students and in technological education

## **4.23 Adapter (AC to DC 12V):**

The main principle, we use this project to reduce the voltage from AC-line 220V to 12V DC. An AC adapter, AC/DC adapter, or AC/DC converter is a type of external power supply, often enclosed in a case similar to an AC plug. Other common names include plug pack, plug-in adapter, adapter block, domestic mains adapter, line power adapter, wall wart, power brick, and power adapter. Adapters for battery-powered equipment may be described as chargers or rechargers (see also battery charger). AC adapters are used with electrical devices that require power but do not contain internal components to derive the required voltage and power from mains power. The internal circuitry of an external power supply is very similar to the design that would be used for a built-in or internal supply.

External power supplies are used both with equipment with no other source of power and with battery-powered equipment, where the supply, when plugged in, can sometimes charge the battery in addition to powering the equipment

## **4.24 LED Light:**

LED (Light Emitting Diode) is basically a small light emitting device that comes under "active" semiconductor electronic components. It's quite comparable to the normal general-purpose diode, with the only big difference being its capability to emit light in different colors. The two terminals (anode and cathode) of a LED when connected to a voltage source in the correct

polarity, may produce lights of different colors, as per the semiconductor substance used inside it.

#### **4.25 Working Principle of LED Light:**

A light-emitting diode is a two-lead semiconductor light source. It is a p–n junction diode that emits light when activated. When a suitable voltage is applied to the leads, electrons are able to recombine with electron holes within the device, releasing energy in the form of photons. This effect is called electroluminescence, and the color of the light (corresponding to the energy of the photon) is determined by the energy band gap of the semiconductor.

#### **4.26 Buzzer:**

This module is a low-cost alarm buzzer called Piezo Buzzer. This device is the alarm for this system. It starts ringing when temperature increases very high and smoke is detected. It also starts ringing when PIR sensor is high.



Figure 4. 15 **Piezo Buzzer.**

#### **4.27 Features of Buzzer:**

1. Rated Voltage: 6V DC
2. Operating Voltage: 4-8V DC
3. Rated current: <30mA

4. Sound Type: Continuous Beep
5. Resonant Frequency: ~2300 Hz
6. Small and neat sealed package
7. Breadboard and Perf board friendly

#### **4.28 Working Principle of Buzzer:**

A **buzzer** is a small yet efficient component to add sound features to our project/system. It is very small and compact 2-pin structure hence can be easily used on breadboard, Perf Board and even on PCBs which makes this a widely used component in most electronic applications.

There are two types are buzzers that are commonly available. The one shown here is a simple buzzer which when powered will make a Continuous Beeeeeppp.... sound, the other type is called a readymade buzzer which will look bulkier than this and will produce a Beep. Beep. Beep. Sound due to the internal oscillating circuit present inside it. But the one shown here is most widely used because it can be customized with help of other circuits to fit easily in our application.

This buzzer can be used by simply powering it using a DC power supply ranging from 4V to 9V. A simple 9V battery can also be used, but it is recommended to use a regulated +5V or +6V DC supply. The buzzer is normally associated with a switching circuit to turn ON or turn OFF the buzzer at required time and require interval.

#### **4.29 Application of Buzzer:**

1. Alarming Circuits, where the user has to be alarmed about something
2. Communication equipment's
3. Automobile electronics
4. Portable equipment, due to its compact size

# Chapter 5

## Results and Discussion

### 5.1 Result

As per our calculation the door slides smoothly and the speed of rotation of motor is controlled by microcontroller, IR sensors are working properly and we have fixed the distance within which they will work properly. We have also checked the working of IR obstacle avoidance sensor. It stops the door closing when someone /car is in between the garage door.

In addition to the above materials and tools, you will need an Android. Device to there are links to the simple commands so that applications for other types of Bluetooth devices Can be created. By connecting the Bluetooth module to a general-purpose relay switch it can switch higher voltages and currents. When the Bluetooth module is reset or not set as an. output, the pin effectively floats - it has a weak pull-down. The Bluetooth board GPIO 3, 6, 7, 10, and 11. Default to low upon power-up and will be off. GPIO 8 and 9. Default to high upon power up and will be on. Finally, the pair of the Bluetooth Module to send the data through the Arduino. The receiving of Arduino to turn on/off control to the motor. When Arduino receive gate open command then reraly-1 on and relay 2 off and motor move forward and gate open. When Arduino receive gate close command then reraly-2 on and relay 1 off and motor move reverse and gate close. When motion sensor detect motion and send information to Arduino then Arduino generate generated alarm. And LDR pin ADC value less than 300 then Arduino turn on light and when LDR value greater than 400 then Arduino turn off light.

### 5.2 Limitations and Problems Encountered

This project encountered certain difficulties that are described below.

Initially, when all the connections were done, the major problem was the connection between the Bluetooth module and the Arduino Uno. It was repeatedly unsuccessful because the Xbee module was used in the project. When the Xbee module was replaced with the HC- 06, the connection was only established after reading about the specifications of the XBEE module and

the HC-06 online. A second problem was also encountered with the use of the fixing of the opt couplers on the board.

### 5.3 Advantages

- Easy to control
- More reliable
- Low implementation cost
- Easy to access
- No extra bill like GSM/ Wi-Fi.

### 5.4 Disadvantage

- We can't control from long distance.

### 5.5 Applications

- House Gurage
- Office Gurage
- House main gate
- Factory or any other place.

### 5.6 Project image

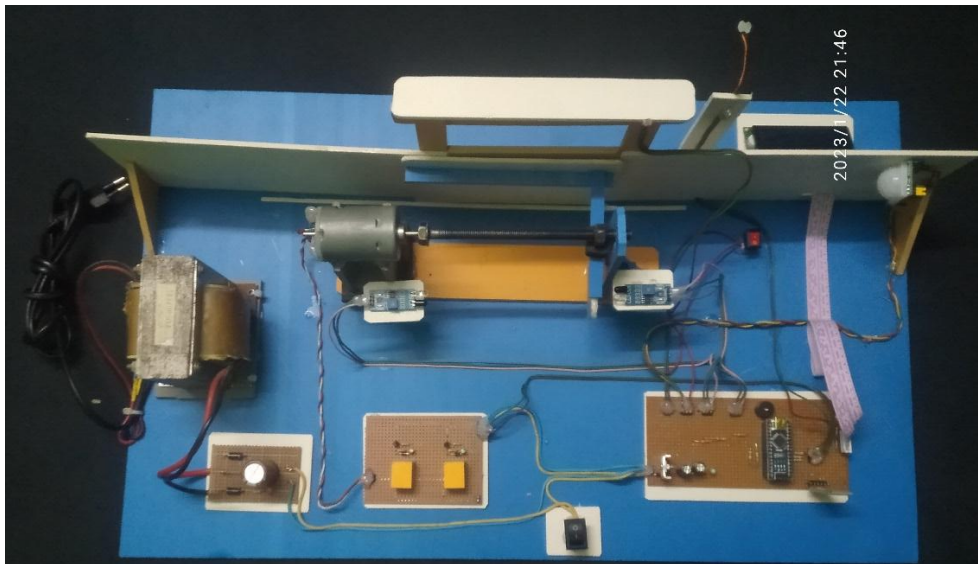

Figure 5. 1 *Project Real picture*

# CHAPTER 6

## CONCLUSION AND FUTURE WORKS

### 6.1 Introduction

The current project presented the implementation of an inexpensive home automation system, within the framework of assistive technology. The system implementation is based on the Arduino microcontroller, which has been programmed to control a range of home automation devices based on sensor signals and on direct commands by the user. The system has been programmed to have Bluetooth communication capability. Demonstrations of the system show that it facilitates the control of home-based devices such as electrical appliances, lights, heating, cooling systems and security devices by the intended users, i.e., the elderly and the disabled.

### 6.2 Conclusion

A project with secured system easily accessible at low cost has designed. We come to know about Arduino programming, electrical circuit, sensor working and some essential mechanical processor and concepts. We also come to know how sensors can be used to make a system more advanced technically. We need to do some reliability test so that the project can be used in future. We can also use the concept behind this project in toll collection and to identify a particular vehicle after some modification.

### 5.3 Future Works

This undertaking proposed a BLE-based passerby route framework for vehicle looking in indoor parking structures. The proposed framework utilizes a neighborhood arrange framework to aid the limitation of parking spots and anchors. Furthermore, the framework embraces the walk-straight-first and turn-by-turn route techniques to manage the person on foot. Toward the objective parking spot. The walk-straight-first procedure infers the briefest course with the base number. Of



changing bearings at crossing points, while the turn-by turn system furnishes. The walker with non-map headings at every convergence prior to arriving at the objective stopping module. Just when the person. On foot shows up at the walkway of the objective leaving module does the vehicle looking application. Show the neighborhood map data of the objective leaving module and accentuate the objective parking spot. Furthermore, the proposed framework has the capacity. To address the passerby's going direction when this direction doesn't adjust to the framework sign. We executed the model of the proposed framework and assessed the framework. Execution. The test results checked the accuracy and adequacy of the proposed framework.

## REFERENCES

1. Schlote, A.; King, C.; Crisostomi, E.; Shorten, R. Delay-Tolerant Stochastic Algorithms for Parking Space Assignment. *Trans. Intell. Transp. Syst.* 2014, 15, 1922–1935.
2. Verroios, V.; Efstathiou, V.; Delis, A. Reaching Available Public Parking Spaces in Urban Environments Using Ad Hoc Networking. In *Proceedings of the 12th IEEE International Conference on Mobile Data Management (MDM 2011)*, Lulea, Sweden, 6–9 June 2011; pp. 141–151.
3. Chen, Z.; Fu, J.; Sun, R.; Han, H. QR Code Location Based Reverse Car-Searching Route Recommendation Model. In *Proceedings of the IEEE International Conference on Vehicular Electronics and Safety (ICVES)*, Hyderabad, India, 16–17 December 2014; pp. 73–77.
4. Fallah, N.; Apostolopoulos, I.; Bekris, K.; Folmer, E. Indoor Human Navigation Systems: A Survey. *Interact. Comput.* 2013, 25, 21–23.
5. Giannopoulos, I.; Kiefer, P.; Raubal, M. GazeNav: Gaze-Based Pedestrian Navigation. In *Proceedings of the 17th International Conference on Human Computer Interaction with Mobile Devices and Services*, Copenhagen, Denmark, 24–27 August 2015; pp. 337–346.
6. Popa, M. Pedestrian Navigation System for Indoor and Outdoor Environments. In *Human—Computer Systems Interaction: Backgrounds and Applications*; Hippe, Z.S., Kulikowski, J.L., Mroczek, T., Eds.; Springer: Berlin/Heidelberg, Germany, 2012; pp. 487– 502.
7. Guo, Q.; Deng, W.; Bebek, O.; Cavusoglu, C.; Mastrangelo, C.; Young, D. Personal Inertial Navigation System Employing MEMS Wearable Ground Reaction Sensor Array and Interface ASIC Achieving a Position Accuracy of 5.5 m over 3 km Walking Distance without GPS. In

Proceedings of the IEEE International Solid-State Circuits Conference, San Francisco, CA, USA, 11–15 February 2018; pp. 180–182.

8. Tariq, Z.B.; Cheema, D.M.; Kamran, M.Z.; Naqvi, I.H. Non-GPS Positioning Systems: A Survey. *ACM Comput. Surv.* 2017, 50, 57.

9. Lee, C.; Chang, Y.; Park, G.J.R.; Jeong, S.; Park, S.; Park, J.W.; Lee, H.C.; Hong, K.; Lee, M.H. Indoor Positioning System Based on Incident Angles of Infrared Emitters. In Proceedings of the 30th Annual Conference of the IEEE Industrial Electronics Society, Busan, Korea, 2–6 November 2004; pp. 2218–2222.

10. Elloumi, W.; Latoui, A.; Canals, R.; Chetouani, A.; Treuillet, S. Indoor Pedestrian Localization with a Smartphone: A Comparison of Inertial and VisionBased Methods. *IEEE Sens. J.* 2016, 16, 5376–5388.

11. Shu, Y.; Bo, C.; Shen, G.; Zhao, C.; Li, L.; Zhao, F. Magicol: Indoor Localization Using Pervasive Magnetic Field and Opportunistic WiFi Sensing. *IEEE J. Sel. Areas Commun.* 2015, 33, 1443–1457.

12. Zhuang, Y.; Yang, J.; Li, Y.; Qi, L.; El-Sheimy, N. Smartphone-Based Indoor Localization with Bluetooth Low Energy Beacons. *Sensors* 2016, 16, 596.

13. Faragher, R.; Harle, R. Location Fingerprinting with Bluetooth Low Energy Beacons. *IEEE J. Sel. Areas Commun.* 2015, 33, 2418–2428.

14. Kriz, P.; Maly, F.; Kozel, T. Improving Indoor Localization Using Bluetooth Low Energy Beacons. *Mob. Inf. Syst.* 2016, 2016, 2083094.
15. Mohebbi, P.; Stroulia, E.; Nikolaidis, I. Sensor-Data Fusion for Multi-Person Indoor Location Estimation. *Sensors* 2017, 17, 2377.
16. Huh, J.H.; Seo, K. An Indoor Location-Based Control System Using Bluetooth Beacons for IoT Systems. *Sensors* 2017, 17, 2917.
17. K. Gill, S.-H. Yang, F. Yao, and X. Lu, "A ZigBee-based home automation system." *Consumer Electronics, IEEE Transactions on*, vol. 55, pp. 4224302009
18. C. Klemenjak, D. Egarter, and W. Elmenreich. "YOMOThe Arduino based smart metering board," arXiv preprint arXiv: 140934042014
19. Duhamel, D.C. (1984) Home Security and Garage Door Operator System, ed: Google Patents,
- 20 F. S. Chai "Design of automatic gate mechanism." UNIVERSITI MALAYSIA PAHANG, 2009,
21. W. Parsadayan, "Safety gate operator which prevents entrapment, and method of its operation. "ed: Google Patents, 2000. [6] H. Luo, "Intelligent Home Security System. Ed: Google Patents, 2006.
22. R. Teich, "Garage door opener with remote safety sensors," ed: Google Patents, 1997

# APPENDIX A

## CODE FOR ARDUINO

```
voisotp()

{

Serial.begin(9600);//Change the baud rate value depending on the default baud rate of your
bluetooth module, for Bluesmirf-115200 and for JY-MCU-9600

pinMode(2,OUTPUT);//Light1 pin

pinMode(3,OUTPUT);//Light2

pinpinMode(4,OUTPUT);//Light3 pin

pinMode(5, OUTPUT);//AC pin

pinMode(6, OUTPUT);//Door Lock

}

void loop()

{

int a=0; if(Serial.available())

{

val=Serial.read();

Serial.println(int(val));//Display received value on Serial Monitor

if(int(val)==49)//Turn Light1 ON digitalWrite(2,HIGH);
```

```
else if (int(val)==50)//Turn Light1 OFF digitalWrite(2,LOW);
```

```
if(int(val)==51)//Turn Light2 ON digitalWrite(3,HIGH);
```

```
else if(int(val)==52)//Turn Light2 OFF digitalWrite(3,LOW);
```

```
if(int(val)==53)//Turn Light3 ON digitalWrite(4,HIGH);
```

```
else if(int(val)==54)//Turn Light3 OFF digitalWrite(4,LOW);
```

```
if(int(val)==55)//Turn AC ON digitalWrite(5,HIGH else if(int(val)==56)//Turn AC OFF  
digitalWrite(5,LOW);
```

```
if(int(val)==57)//Lock the DOOR digitalWrite(6,HIGH);
```

```
else if(int(val)==48)//Unlock the DOOR digitalWrite(6,LOW);
```

```
}
```

```
}
```