

# **Design, Construction and Performance Test Boiler Water Flow and Temperature Control System**

A thesis report submitted to the department of mechanical engineering for the partial fulfillment of the degree of Bachelor of Science in Mechanical Engineering

A Thesis by

Name: MD. ZAHID HASAN

ID No: ME 2102024564

Name: S M SAZID HOSSAIN

ID No: BME 1902018314

Name: AKM JAHANGIR ALAM

ID No: BME 1601008334

Name: MD TAZUL ISLAM

ID No: BME 1902018244



Supervisor:

Md. Ahatashamul Haque Khan Shuvo  
Assistant Professor & Course Coordinator  
Department of Mechanical Engineering  
SONARGAON UNIVERSITY (SU)

Dhaka, Bangladesh  
January 2023

## **APPROVAL**

This is to certify that the project on “**Design, Construction and Performance Test Boiler Water Flow and Temperature Control System**”, By Md. Zahid Hasan (ID No: ME 2102024564), S M Sazid Hossain (ID No: BME 1902018314), AKM Jahangir Alam (ID No: BME 1601008334), Md. Tazul Islam (ID No: BME 1902018244) has been carried out under our supervision. The project has been carried out in partial fulfillment of the requirements of the degree of Bachelor of Science (B.Sc.) in Mechanical Engineering of years of 2023 and has been approved as to its style and contents.

Md. Ahatashamul Haque Khan Shuvo  
Assistant professor & Course Coordinator  
Department of Mechanical Engineering  
Sonargaon University (SU)

## DECLARATION

We, hereby, declare that the work presented in this project is the outcome of the investigation and research work performed by us under the supervision of Md. Ahatashamul Haque Khan Shuvo, Assistant professor & Course Coordinator, Department of Mechanical Engineering, Sonargaon University (SU). We also declare that no part of this project and thesis has been or is being submitted elsewhere for the award of any degree.

Md. Zahid Hasan

ID No: ME 2102024564

S M Sazid Hossain

ID No: BME 1902018314

AKM Jahangir Alam

ID No: BME 1601008334

Md. Tazul Islam

ID No: BME 1902018244

## ACKNOWLEDGEMENT

First of all, we are grateful to Allah, the almighty for giving us the courage and enthusiasm to complete the thesis work. The authors express their gratitude to “Md. Ahatashamul Haque Khan Shuvo” for his constant & meticulous supervision, valuable suggestion and encouragement to carry out this work. For all this, the authors acknowledge their sincere gratitude to him. We are also grateful to all our thesis & project working team of SU for their help in construction of the project work and give their valuable knowledge and time for completing the experiment. Finally, we would like to thank everybody who supported us in any respect for the completion of the thesis.

### Authors

Md. Zahid Hasan

ID No: ME 2102024564

S M Sazid Hossain

ID No: BME 1902018314

AKM Jahangir Alam

ID No: BME 1601008334

Md. Tazul Islam

ID No: BME 1902018244

## **Abstract**

Boiler is the main component in generating steam in thermal power generation units and its control is very important in many applications. In present situation conventional PID control is being used for this purpose. These conventional controllers in power plants are not very stable when there are fluctuations and, in particular, there is an emergency occurring. Continuous processes in power plant and power station are complex systems characterized by nonlinearity, uncertainty and load disturbances. The conventional controllers do not work accurately in a system having nonlinearity in it. So, an intelligent control using fuzzy logic is developed to meet the nonlinearity of the system for accurate control of the boiler steam temperature and water level. The Control system of the industry boiler water level is designed. The control algorithm used normalized PID control algorithm based traditional PID. A normalized parameter setting method is introduced for adjustment of PID parameters. The boiler water level control system is designed based on the Kingview software development platform. The main controller is realized with PLC. The configuration software is used to configure hardware and network. The experimental results prove that the combination of the PLC control system and Kingview configuration software is valuable for design, testing and application.

## List of Contents

|   |             |
|---|-------------|
| <b>APPROVAL</b>                                 | <b>VI</b>   |
| <b>DECLARATION</b>                              | <b>VII</b>  |
| <b>ACKNOWLEDGEMENT</b>                          | <b>VIII</b> |
| <b>ABSTRACT</b>                                 | <b>IX</b>   |
| <b>LIST OF CONTENTS</b>                         | <b>X</b>    |
| <b>LIST OF FIGURES</b>                          | <b>XIII</b> |
| <br>  |             |
| <b>CHAPTER 1</b>                                | <b>1</b>    |
| <hr/>   |             |
| <b>INTRODUCTION</b>                             | <b>1</b>    |
| 1.1 INTRODUCTION                                | 1           |
| 1.2 OBJECTIVE:                                  | 2           |
| <br>  |             |
| <b>CHAPTER 02</b>                               | <b>3</b>    |
| <hr/>   |             |
| <b>LITERATURE REVIEW</b>                        | <b>3</b>    |
| 2.1 BOILER:                                     | 3           |
| 2.2 THE FUNCTION OF BOILER LEVEL CONTROL SYSTEM | 3           |
| 2.3 THE DESIGN OF SOFTWARE SYSTEM               | 7           |
| 2.4 CHEMICAL DRAIN CLEANERS                     | 7           |
| 2.5 THE DESIGN OF MAIN MONITORING INTERFACE     | 8           |
| 2.6 THE DESIGN OF ALARM SYSTEM                  | 9           |
| 2.7 THE DESIGN OF TREND CURVE                   | 9           |
| 2.8 PARAMETER SETTING                           | 9           |
| 2.9 THE DEBUGGING OF THE CONTROL SYSTEM         | 9           |
| <br>  |             |
| <b>CHAPTER 03</b>                               | <b>11</b>   |
| <hr/>   |             |
| <b>METHODOLOGY</b>                              | <b>11</b>   |
| 3.1 PROCESS OF PROJECT:                         | 11          |
| 3.2 WORKING PRINCIPAL:                          | 12          |
| 3.2.1 CURRENT SCENARIO OF BOILER CONTROL        | 12          |
| 3.2.2 PROPOSED METHODOLOGY                      | 13          |

|   |    |
|---|----|
| 3.2.3 TEMPERATURE MONITORING & CONTROL                    | 14 |
| 3.2.4 TEMPERATURE CONTROL                                 | 14 |
| 3.2.5 LEVEL CONTROL                                       | 14 |
| 3.3 REQUIRED COST ANALYSIS:                               | 15 |
| 3.4 ARDUINO NANO MICROCONTROLLER BOARD                    | 16 |
| 3.4.1 DEFINING ARDUINO NANO                               | 16 |
| 3.4.2 ARDUINO ARCHITECTURE:                               | 16 |
| 3.4.3 ARDUINO PIN DIAGRAM                                 | 17 |
| 3.4.4 HOW TO PROGRAM AN ARDUINO?                          | 17 |
| 3.4.5 5 STEPS TO PROGRAM AN ARDUINO                       | 18 |
| 3.4.6 FEW OF BASIC ARDUINO FUNCTIONS ARE:                 | 18 |
| 3.4.7 HOW TO DESIGN YOUR OWN ARDUINO?                     | 19 |
| 3.4.8 7 REASONS WHY ARDUINO IS BEING PREFERRED THESE DAYS | 19 |
| 4.2.8A IT IS INEXPENSIVE                                  | 19 |
| 4.2.8A IT IS EASY TO USE FOR BEGINNERS.                   | 20 |
| 3.5 POWER SUPPLY  | 20 |
| 3.5.1 TRANSFORMER   | 20 |
| 3.5.2 WORKING OF THIS TRANSFORMER                         | 21 |
| 3.6 DIODE   | 21 |
| 3.6.1 CHARACTERISTICS CURVE OF DIODE                      | 22 |
| 3.6.2 FULL-WAVE RECTIFIERS                                | 22 |
| 3.6.3 WORKING OF A BRIDGE RECTIFIER                       | 23 |
| 3.7 CAPACITOR   | 24 |
| 3.7.1 THEORY OF OPERATION                                 | 25 |
| 3.8 VOLTAGE REGULATOR                                     | 26 |
| 3.9 SIM 800L GSM MODULE                                   | 26 |
| 3.9.1 INTRODUCTION:                                       | 26 |
| 3.9.2 SIM800L OVERVIEW:                                   | 26 |
| 3.9.3 SIM800L KEY FEATURES:                               | 28 |
| 3.9.6 FUNCTIONAL DIAGRAM                                  | 31 |
| 3.9.6 PIN OUT DIAGRAM                                     | 31 |
| 3.9.7 PIN DESCRIPTION                                     | 32 |
| 3.9.9A POWER ON SIM800L                                   | 37 |
| 3.10 LCD DISPLAY  | 38 |

|  |           |
|--|-----------|
| 3.10.1 WHAT IS A LCD (LIQUID CRYSTAL DISPLAY)? | 38        |
| 3.10.1 HOW LCDS ARE CONSTRUCTED?               | 39        |
| 3.10.2 HOW LCDS WORK?                          | 40        |
| 4.8.2A ADVANTAGES OF AN LCD'S:                 | 40        |
| 3.10.2B DISADVANTAGES OF AN LCD'S:             | 41        |
| 3.11 RELAY                                     | 41        |
| 3.11.1 POLE AND THROW                          | 42        |
| 3.11.2 CONSTRUCTION OF RELAY                   | 42        |
| 3.11.2 CONTACTS                                | 43        |
| 3.11.3 BEARING                                 | 43        |
| 3.11.4 ELECTROMECHANICAL DESIGN                | 43        |
| 3.11.5 TERMINATIONS AND HOUSING                | 43        |
| 3.11.6 HOW RELAYS WORK                         | 43        |
| <b>CHAPTER 4</b>                               | <b>45</b> |
| <b>RESULT AND DISCUSSION</b>                   | <b>45</b> |
| 4.1 RESULT:                                    | 45        |
| 4.2 DISCUSSION:                                | 45        |
| 4.3 FUTURE SCOPE                               | 46        |
| <b>CHAPTER 5</b>                               | <b>47</b> |
| <b>CONCLUSION</b>                              | <b>47</b> |
| 5.1 ADVANTAGES:                                | 47        |
| 5.2 APPLICATIONS:                              | 47        |
| 5.3 CONCLUSION:                                | 48        |
| 5.4 FUTURE SCOPE:                              | 48        |
| <b>REFERENCES</b>                              | <b>49</b> |
| <b>APPENDIX</b>                                | <b>50</b> |



## List of Figures

|   |    |
|---|----|
| Figure 2. 1 Structure of level control .....                                      | 5  |
| Figure 2. 2 Hardire control.....  | 6  |
| Figure 2. 3 Main monitoring sysytem.....  | 7  |
| Figure 2. 4 Operation result .....  | 10 |
| <br>  |    |
| Figure 3. 1Block Diagram of Boiler water flow and temperature control system..... | 11 |
| Figure 3. 2 Boiler water flow and temperature control system.....                 | 12 |
| Figure 3. 3 Process of FLC based boiler control .....                             | 13 |
| Figure 3. 4 Fuzzy interface system .....  | 14 |
| <br>  |    |
| Figure 4. 1 Arduino NANO .....  | 16 |
| Figure 4. 2 Arduino Architecture:.....  | 16 |
| Figure 4. 3 Arduino pin diagram.....  | 17 |
| Figure 4. 4 Arduino programming process .....                                     | 18 |
| Figure 4. 5 AC-DC Power Supply & Circuit Diagram.....                             | 20 |
| Figure 4. 6 Diode and symbol.....   | 21 |
| Figure 4. 7 Junction diode symbol and static I-V characteristics .....            | 22 |
| Figure 4. 8 Bridge rectifier circuit .....  | 23 |
| Figure 4. 9 Input sine wave.....  | 23 |
| Figure 4. 10 Pulsating DC output .....  | 23 |
| Figure 4. 11 Capacitors & Capacitor symbols. ....                                 | 24 |
| Figure 4. 12 Internal constriction of capacitors .....                            | 25 |
| Figure 4. 13 Voltage regulator output voltages. ....                              | 26 |
| Figure 4. 14 Overview of SIM800L GSM Module .....                                 | 27 |
| Figure 4. 15 Package Information.....   | 27 |
| Figure 4. 16 SIM800L Pin out diagram .....  |    |
| Figure 4. 17 Reference circuit of the DC-DC power supply .....                    | 36 |
| Figure 4. 18 16x2 LCD (Liquid Crystal Display).....                               | 38 |
| Figure 4. 19 Simple facts that should be considered while making an LCD:.....     | 39 |

## **Chapter 1**

### **Introduction**

#### **1.1 Introduction**

The boiler liquid level is a very important parameter. It is particularly important for boiler liquid level control system [1]. The PID control algorithm has been widely used in industrial [2] because the PID algorithm is accuracy and real-time. According to the dynamic characteristics of the control object, PID algorithm is used in P, PI, and PID control regulation. The most complex control uses the PID control law. But because of its parameter setting complexity and specialization, many applications are blocked. A normalized parameter setting method is introduced for parameter adjustment, which is greatly convenient for users to use. Configuration software Kingview is general configuration software which has such advantage as ease for use, openness, integration, and can complete the real-time multitask control [3][4]. Application of Kingview can also enable the engineer to focus on control object, instead of every communication protocol, complex graphics, and boring statistics [5]. The enterprise integrated automation can be realized. A real-time boiler liquid level monitoring and control system is designed based on Kingview software and PLC controller.

Temperature controllers are needed in any situation requiring a given temperature be kept stable. This can be in a situation where an object is required to be heated, cooled or both and to remain at the target temperature (set point), regardless of the changing environment around it. Temperature controllers are used in a wide variety of industries to manage manufacturing processes or operations. There are several reasons for using automatic temperature controls for steam applications. For some processes, it is necessary to control the product temperature to within fairly close limits to avoid the product or material being processed being spoiled. Steam flashing from boiling tanks is a nuisance that not only produces unpleasant environmental conditions, but can also damage the fabric of the building. Automatic temperature controls can keep hot tanks just below boiling temperature. Also, for economy, quality and consistency of production, saving in manpower, comfort control, safety and to optimize rates of production in industrial processes boiler temperature control is necessary.

Conventional control system in power station adopts PID controller. system could not attain well result by using PID parameter which previously set. Since the introduction of fuzzy set

theory by Zadeh and the first invention of a fuzzy controller by Mamadani, fuzzy control has gained a wide acceptance, due to the closeness of inference logic to human thinking, and has found applications in some power plants and power systems. It provides an effective means of converting the expert-type control knowledge into an automatic control strategy. A fuzzy control mainly simulates control experience of human and gets rid of control object. It discusses definite nature, fuzzy and imprecise information system control in the real world.

[ref. 1 & 3]

## **1.2 Objective:**

The objectives of this thesis are:

- a) To design and construct a boiler water flow and temperature control system
- b) To test the performance of boiler water flow and temperature control system
- c) Use GMS system to get result.

## **Chapter 02**

### **Literature Review**

#### **2.1 Boiler:**

The boiler is the mechanical equipment that the water is heated into hot water or steam by using of fuel or other heat energy. The boiler can be used to provide continuous hot water and central house heating. Boiler water level is an important parameter of the boiler to ensure the normal operation. That the level is too low will affect the steam amount, then tends to dry out and even results into a serious accident, while the higher level will cause steam with entrained water and even overflow. Therefore, the boiler level must strictly be controlled [6][7]. Boiler liquid level is considered as the controlled variable. The main factors that change the boiler liquid level includes as follows: one is the boiler inflow; another is the boiler water yield. The change of the boiler water yield takes a certain time to react to the boiler level changes, but with relatively large time constant and longer time delay, which has not timely controlled to the system, weak anti-jamming capability and poor control accuracy.

#### **2.2 THE FUNCTION OF BOILER LEVEL CONTROL SYSTEM**

The history of drain cleaners parallels the development of common drain systems themselves. As a result, there is not an extensive history of cleaners in the US, as municipal plumbing systems were not readily available in middle-class American homes until the early 20th century. Prior to this time, Americans often discarded the dirty water collected in basins after use. Limited piping systems gradually developed with lead materials, but after WWI when the poisonous properties of lead became more well-known, piping was reconstructed with galvanized iron. Galvanized iron is actually steel covered in a protective layer of zinc, but it was soon discovered that this zinc layer naturally corroded due to exposure to the atmosphere and rainwater, as well as cement, runoff, etc. Once corrosion occurred down to the base metal, plaques and rust would form, leading to sediment build-up that would gradually clog these drains. Thus, the first motivation for drain cleaners came to be. The struggle against corroding galvanized iron pipes eventually led to a replacement by copper or plastic (PVC) piping by the 1960s. Copper and plastic do not possess that zinc layer that naturally corrodes to

expose the base metal to decay. Still, however, natural substances such as hair, grease, or other oils continued to be an issue in drain clogs, and so, the development of more effective chemical drain cleaners became necessary.

Therefore, the system by using the realtime monitoring and control system based on Kingview software improves the control accuracy, and through PID control [8] makes the boiler level vary with the given value. Furthermore, when the system suffers disturbance, the level will finally stabilize at the given value. The monitoring and control system adjusts the inlet valve opening according to the boiler level  $h$ , thus allows eventually the level  $h_r$  reach the setting value  $h_c$ , and finally meets the control requirements.

### THE ALGORITHM OF WATERLEVEL CONTROL

The output of the PID controller for boiler water level control system is showed as formula

$$u(t)=K_p e(t)+k_i \int_0^t e(t)dt+K_D \frac{de(t)}{dt} \quad (1)$$

where  $K_P$  is the proportional coefficient,  $K_I=K_P \cdot T/T_I$  is the integral coefficient,  $T_I$  is the integral time,  $T$  is the sampling period,  $K_D=K_P \cdot T_D/T$  is the differential coefficient,  $T_D$  is differential time. The role of PID algorithm as follows:

- (1) Proportion: Reflect the difference between the signal control system, deviation once generated, regulator immediately produce the control, reduce the error.
- (2) Integral: To eliminate the static error, and improve the system stability, integral time constant  $T_I$  increased integral effect is weak, whereas stronger.
- (3) Differential: To reflect the variation trend of deviation in the deviation becomes too large, before effective introduction of early correction of signal, to reduce the time of system regulation. The formula (2) can be expressed as the following by discretization formula (3) [9]:

$$u(k)=K_p e(k)+K_i \sum_{i=0}^k e(i)+K_D [e(k)-e(k-1)] \quad (2)$$

The incremental formulation for digital PID algorithm [10]

is:

$$\begin{aligned} \Delta u(k) &= u(k)-u(k-1) \\ &= K_p [e(k)-e(k-1)]+K_i e(k)+K_D [e(k)-2e(k-1)+e(k-2)] \quad (3) \end{aligned}$$

where  $u(k)$  is the controller output,  $u(k-1)$  is the last time controller output,  $e(k)$  is the error

signal of this time,  $e(k-1)$  is the error signal of last time,  $e(k-2)$  if the error signal before last time.

As a rule of thumb, we can set the relationships between the time parameters. namely the constraint conditions. Lets:

$$T=0.1T_s, T_i=0.5T_s, T_D=0.125T_s \quad (4)$$

from 3 & 4, we get

$$\Delta u(k)=K_P[2.45e(k)-3.5e(k-1)]+1.25E(k-2)] \quad (5)$$

This formula is the PID algorithm of normalized parameters. In formula (5) only one parameter needs adjusted. We will obtain the satisfied control effect through experiments on the adjustment of the proportional coefficient  $K_P$ . Normalized adjustment of PID parameters is applied in boiler liquid level control system. The normalized PID parameter adjustment method is the three adjustment parameters normalized to a parameter adjustment. The PID control parameters are obtained from the adjustment parameter multiplied by a respective normalized coefficient. The enable adjustment parameter is the proportional coefficient  $K_p$ . The flowchart of the boiler level control system is given in Figure 1, where  $e(k)$ ,  $e(k-1)$ ,  $e(k-2)$  is the deviation in the order of  $k$ -th, the  $(k-1)$ -th,  $(k-2)$ -th,  $u(k)$ ,  $u(k-1)$  the controller output of the  $k$ -th,  $(k-1)$ -th, and  $h(k)$ ,  $h(k-1)$  the actual boiler level of the  $k$ -th,  $(k-1)$ -th,  $k$  is the counting value of sampling point. The output of the normalized PID controller is obtained as formula (6). The real boiler liquid level  $h(k)$  is calculated by using the following formula (7). Where  $K_v$  is the valve proportion coefficient,  $T_1$  is time constant

$$u(k) = u(k-1) + \Delta u(k) \quad (6)$$

$$h(k) = \frac{K_v T}{T_1 + T} u(k) + \frac{T_1}{T_1 + T} h(k-1) \quad (7)$$

**THE DESIGN OF HARDWARE SYSTEM** The control system structure shows in Figure 2, where the transmitter is used to convert actual level into the analog electrical signal and transmit to the control center or display devices. The output signal of transmitter depends on the specific application, of which some are simulation, other digital. Figure 2 is a structure diagram of continuous system, which cannot design the digital controller until discrete treatment.

The system hardware structure diagram is given in Figure

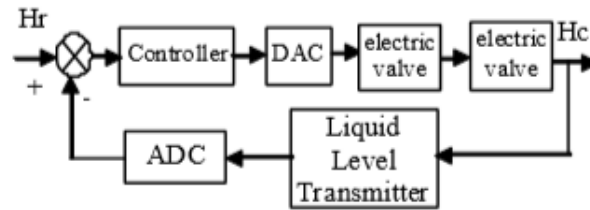

Fig. 2. Structure of level control system

The industrial control computer is used as host controller of the liquid level control system. The programmable logic controller (PLC) is used as slave controller of the liquid level control system. The interface of slave controller includes the analog to digital converter (ADC) and the digital to analog converter (DAC). The PCL-818L is the ADC module from YanHua corporation. The PCL-726L is the DAC module from YanHua. The actuator of control system use the electromagnetic valve. In figure 3, the liquid level sensor and the turbine flowmeter via standard industry connector box send the collected data to DAC module from YanHua Corporation, through RS485/RS232 by PLC, and then send out data to the host computer, which records and analysis. According the results PLC transmits control signals to the electronic valve, and then changes the valve opening, finally finishes the purposes that adjust the boiler inflow to achieve control. [ref.1 & 3]

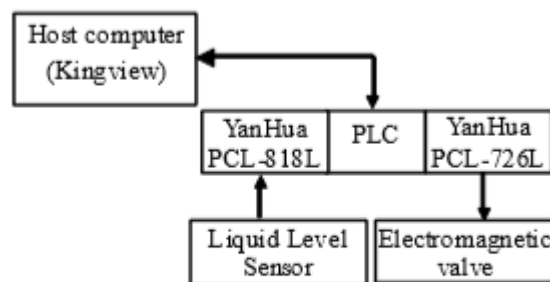

Fig. 3. Hardware of control system

## **2.3 THE DESIGN OF SOFTWARE SYSTEM**

A. Brief Introduction of Kingview the KingviewV6.52 is the configuration software, which can be run in Windows XP/NT/2000. The KingviewV6.52 configuration software uses the new technology of multithread, COM, components etc. The KingviewV6.52 configuration software makes full use of the Windows graphic editing functions, also can be to realize real-time multi-tasking control. The KingviewV6.52 configuration software is composed of ProjManager, Touch Explorer and Touch View. The Kingview configuration software can enable the engineer to focus on control object, instead of every communication protocol, complex graphics and boring statistics so that we realize the enterprise integrated automation.

B. The Design of Main Monitoring Interface The main monitoring interface of boiler level control system shows as Figure 4, where the monitoring picture can directly reveal the dynamic changes of the object parameters. Moreover, the monitoring picture according to control result implements of data receiving, processing and sending to achieve the boiler level control in real time. Its main functions include: dynamic controls which display the boiler level changes in real time, parameter setting that can accomplish the setting of PID parameters.

C. The Definition of Database Variables Database of variables in the set is called data dictionary, which records detailed information of data variables for all users. These variables include the memory variables and I/O variables that are directly exchanged with external data acquisition program. While memory variables are only for the Kingview, but not used in other applications. Click on browser current project, after that click on "data dictionary" in the directory filed, which shows "new" icon that finishes the variable definition. [ref. 2]

## **2.4 Chemical Drain Cleaners**

Be they liquid, gel or powder form, most of the drain cleaners you'll find on store shelves use strong chemicals, and they come in liquid, gel and powder forms. All chemical reactions involve moving electrons, and drain cleaners work by either taking or giving electrons to the clogging substance, generating heat in the process. There are three main types of drain cleaners:

Aside from their effect on pipes, there are other disadvantages to chemical drain cleaners. They're extremely toxic if swallowed, and they can burn eyes, skin and mucous membranes and eat through clothing. They can release noxious fumes, and if used improperly, they can cause explosions. These products can also harm septic systems by killing beneficial bacteria, and they can mar bathroom and kitchen fixtures.



If you use chemical drain cleaners, read the directions carefully and heed all the warnings. Use the product in a well-ventilated area, wear rubber gloves, and keep children and pets away from the drain. Never mix different drain cleaners, and don't use a plunger in conjunction with drain cleaners.

Most drain cleaners advise waiting 15 minutes or more after pouring the product into the drain before flushing it with hot water. If your drain is still clogged afterward, you may need to repeat the process.

## 2.5 The Design of Main Monitoring Interface

The main monitoring interface of boiler level control system shows as Figure 4, where the monitoring picture can directly reveal the dynamic changes of the object parameters. Moreover, the monitoring picture according to control result implements of data receiving, processing and sending to achieve the boiler level control in real time. Its main functions include: dynamic controls which display the boiler level changes in real time, parameter setting that can accomplish the setting of PID parameters.

C. The Definition of Database Variables Database of variables in the set is called data dictionary, which records detailed information of data variables for all users. These variables include the memory variables and I/O variables that are directly exchanged with external data acquisition program. While memory variables are only for the Kingview, but not used in other applications. Click on browser current project, after that click on "data dictionary" in the directory filed, which shows "new" icon that finishes the variable definition.

Fig

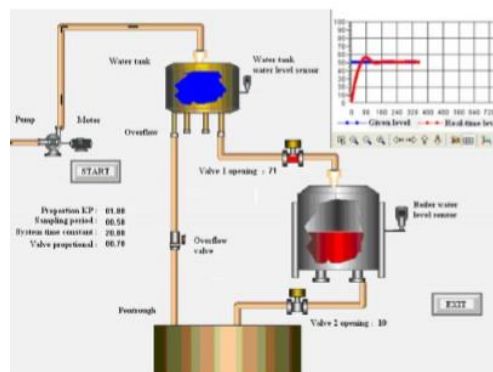

Fig. 4. main monitoring interface

After selecting the "device/card" in the Touch Explorer interface, the project directory appears on the right side. Later on, double click the "new" icon, according to "equipment configuration guide", and establish the card device "Yanhua PCL\_818L". Finally, set up I/O variable for system. In this way, industry computer collects signal from the field, and also sends operation value to actuators.

## **2.6 The Design of Alarm System**

In Kingview TouchExplorer directory, after choosing "database alarm group", double click on the Icon of "please double click here to enter < alarm group > dialog box..." showed in the right area. Then popup the dialog for the alarm group definitions, as well as set the variables alarm attribute and alarm group for the project (such as boiler level alarm).

## **2.7 The Design of Trend Curve**

Trend curve, including real-time trend curve and history trend curve, is used to reflect the change of the data variables with time. The difference between the two kinds of trend curves is that during running the picture program, real-time trend curve rolls automatically with time, and responds the latest variables change, therefore cannot reflect the variable history data. The history trend curve can observe the historical data, but it does not automatically scroll. In the establishment of two kinds of trend curves, the X, Y scale interval and data update frequency etc are also needed to define.

## **2.8 Parameter Setting**

When system is running, the user can modify the boiler level given value and can adjust PID control parameters. The interface window of parameter setting is included in the main monitoring interface window. The actual boiler level will track the given value by control system.

## **2.9 THE DEBUGGING OF THE CONTROL SYSTEM**

The control system can be debugged by using the simulation PLC and the simulation I/O equipment. When program is debugging and testing the data of the monitoring picture is provided from the simulation I/O equipment and the simulation slaved controller. When debugging, TOUCHVIEW is processed continuously so that the digital controller improves to a better point. This design uses the PLC system simulation software to realize the function of

simulation and test, when the program debugging, provides data to the screen using the simulation of I/O device simulation computer, provide a convenient debugging for picture program. KingView to provide a simulation of PLC equipment, used to simulate the actual equipment to provide data for the user program debugging. Online testing and analysis data, the performance test system meets the design requirements. Revising "valve proportional coefficient" and "PID proportional coefficient KP", so that the control accuracy can meet the design requirements. The sampling period  $T=0.5s$ , this design using  $T1=20$ , and by changing the PID proportional coefficient KP, valve proportional coefficient KI value. The test data as shown in Figure 5, and figure 6. The operation results is shown in Figure 5 while  $KP=1$ ,  $KI=0.7$ . The operation results are shown in Figure 6 while  $KP=2$ ,  $KI=1.5$ .

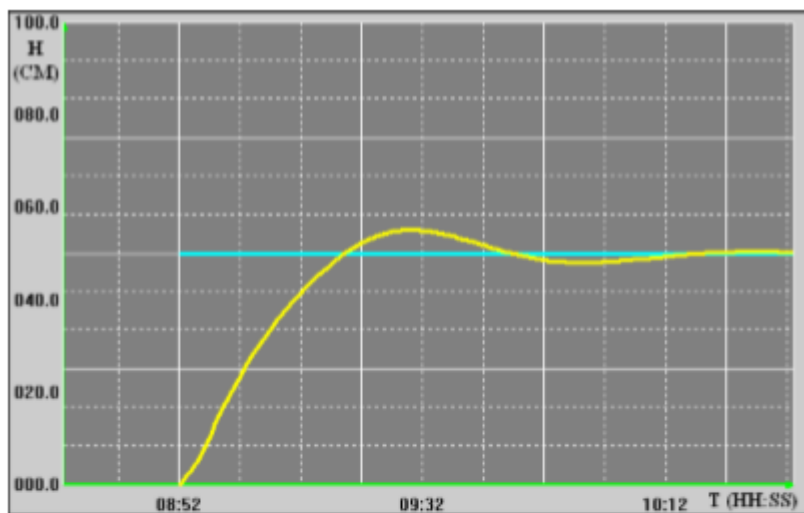

Fig. 5. The operation results while  $KP=1$ ,  $KI=0.7$

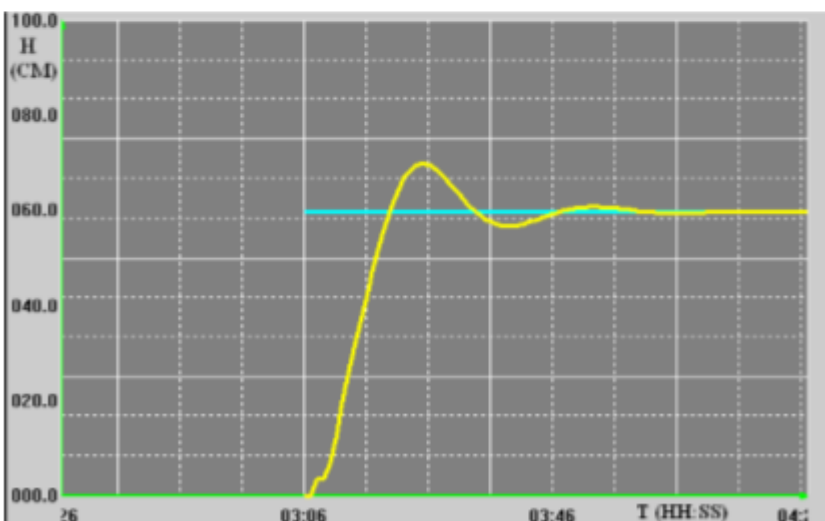

Fig. 6. The operation results while  $KP=2$ ,  $KI=1.5$

Figure 2. 1 Operation result

The results show that the rise time of the system is improved, but the relatively large amplitude oscillation while  $K_P=2$ ,  $K_I=1.5$ . After Determining the appropriate parameters, such as  $K_P=2$ ,  $K_I=1.5$ , remain constant. After the output of controller is good point, then the actual PLC is accessed in control system by keeping the parameters unchanged, and observes whether the actual boiler level is tracking the given value under the requirement of  $t_p \leq t_r$ . Repeat the operation for control system until the satisfied effect is reached. [ref. 6]

## Chapter 03

### Methodology

[ref. 5 & 6]

#### 3.1 Process of Project:

- Creating an idea for Design and construction of Android Control Automatic Drain Cleaner.
- And designing a block diagram & circuit diagram to know which components need to construct it.
- Collecting the all components and programming for the microcontroller to controlled the system.
- Setting all components in a PCB board & soldering. Then assembling the whole block in a board and finally run the system & checking.

#### 3.2 Block Diagram:

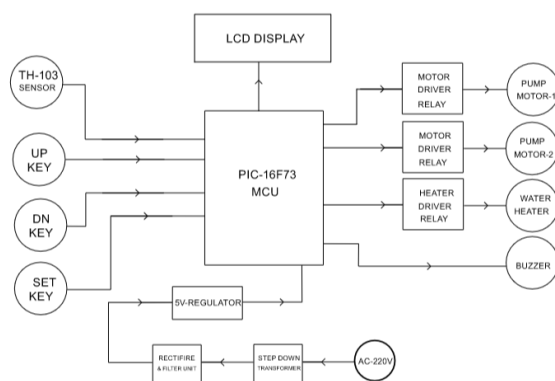

BLOCK DIAGRAM :BOILER WATER TEMPERATURE AND FLOW CONTROL AND MONITORING SYSTEM

Figure 3. 1Block Diagram of Boiler water flow and temperature control system

#### 3.1 Circuit Diagram:

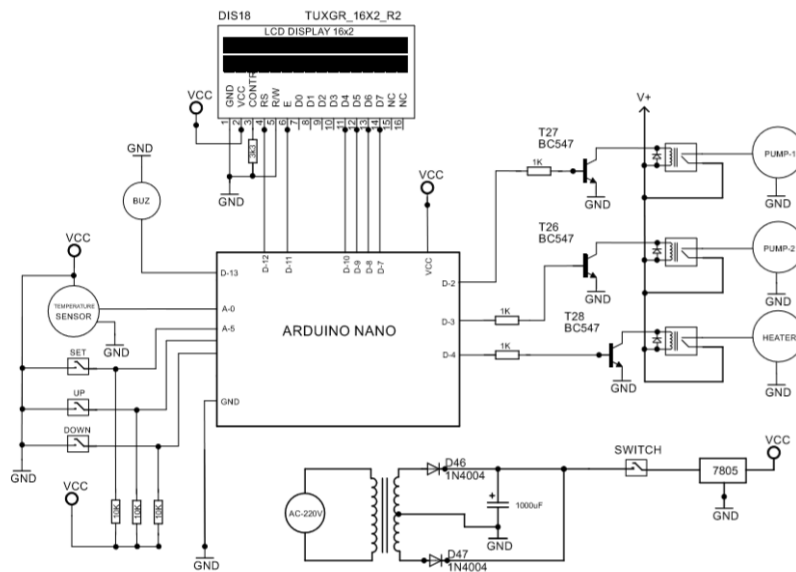

Figure 3. 2 Boiler water flow and temperature control system

## 3.2 Working Principal:

### 3.2.1 CURRENT SCENARIO OF BOILER CONTROL

In electric boilers, the resistance of the water to the passage of electricity generates heat and steam. No part of the generator is ever hotter than the water or steam itself. Therefore, no baking of solids or residue occurs. Furthermore, when the electrode tips become uncovered, no current can pass, hence, no low water damage can occur. Within the pressure vessel of the generator, a cylinder, open at the bottom, is welded to the inside of the upper-head of a pressure vessel. This cylinder divides the vessel into two concentric chambers. The outer chamber (K) is the regulating chamber. The inner chamber (J) is the generating chamber. Suspended within the generating chamber are the electrodes (N). Electric power (P) is easily connected to the three electrode terminals. A prescribed quantity of Electrolyte is dissolved in water and poured into the generator through the hand fill (G). This Electrolyte remains in the generator until drawn off with the water through the drain valve (M). Electric power is turned on, and heat is generated by the resistance of the water to the passage of current between the solid electrodes. Steam produced in the generating chamber (J) flows through the steam valve outlet (I), and via the steam header (E), through the pressure regulating valve or(C) to the regulating chamber (K). Before the electric boiler is turned on, water levels would be balanced. Adjusting the screw on the pressure regulator valve (D) sets the desired pressure. When the system is turned on, air is automatically exhausted through the air eliminator (A), which closes when heated by the steam. If the steam consumed is less than maximum, pressure built-up in the generator chamber until it reaches the pressure limit set by the

pressure regulator. At this point the pressure regulator valve partially closes, reducing the amount of steam entering the regulating chamber. This unbalances the system momentarily, permitting the water to rise in the regulating chamber due to the higher-pressure condition in the generating chamber. As the water level drops in the generating chamber the electrodes are progressively exposed, and the amount of steam being generated decreases. Inasmuch as current input is proportional to the immersed area of the electrodes, the falling water level reduces the electric input. Conversely, if heavy use of steam tends to lower the desired pressure, the regulating valve opens wide, allowing more steam into the regulating chamber. These forces water back into the generating chamber, increasing the flow of current and rate of steam production by completely enveloping the electrodes. The water level in both chambers is rarely balanced. This condition occurs only at full load. [ref. 2]

### 3.2.2 PROPOSED METHODOLOGY

The proposed method consists of two sections. First section is to develop a steam temperature monitoring and control system and the second section consists of water level control. For both of the sections Fuzzy Logic Control will be used. A microcontroller will be programmed with the fuzzy knowledge base rule. The temperature sensor will be interfaced with the microcontroller to monitor the steam temperature and a level indicator circuit will be interfaced with the microcontroller which will indicate the water level inside the boiler chamber. The microcontroller will take the temperature sensor output and level indicator output as the two inputs for the Fuzzy Inference System. After fuzzification of the inputs and applying suitable rules and defuzzifying the output the microcontroller generates appropriate control signals.

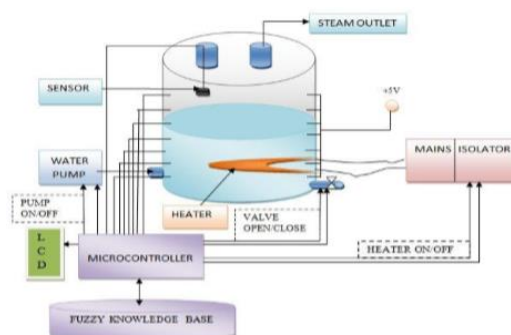

Fig.2. Proposed FLC based boiler control

Figure 3. 3 Process of FLC based boiler control

### 3.2.3 TEMPERATURE MONITORING & CONTROL

#### Temperature Monitoring

The temperature is measured using the sensor. The sensor output is compared with the set value. The error or deviation from the set value is given as an input to the fuzzy logic control system.

#### 3.2.4 Temperature Control

The Fuzzy Inference system fuzziest the inputs and applies suitable rules and calculates the defuzzified value. □ It then decides the suitable control action to be performed. □ The microcontroller gives command to perform the required control action to turn the heater ON/OFF for safe operation of the boiler.

### 3.2.5 LEVEL CONTROL

The water level control is also an important parameter for boiler control. The water level inside the boiler chamber needs to be controlled because of changing load demand. When there is a need of more steam water level should be high and when there is a need of less steam the water level should be low. To maintain the water level inside the boiler, chamber a level indicator circuit is used and the circuit is interfaced with the microcontroller. The Fuzzy Inference System stored inside the microcontroller then fuzziest the inputs and applies suitable rules and then gives the defuzzified values which is then processed by the microcontroller to give the suitable control action to turn ON/OFF the inlet pump and OPEN/CLOSE the outlet valve.

#### FUZZY INFERENCE SYSTEM

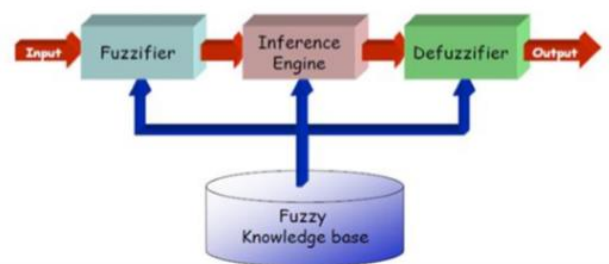

Fig.6. Block diagram of fuzzy inference system

Figure 3. 4 Fuzzy interface system

### 3.3 Required cost analysis:

#### LIST OF COMPONENTS

| SL  | COMPONENT NAME     | QTY | PRICE         |
|-----|--------------------|-----|---------------|
| 1.  | ARDUINO NANO       | 1   | 350           |
| 2.  | 16X2 LCD DISPLAY   | 1   | 200           |
| 3.  | TEMP SENSOR        | 1   | 200           |
| 4.  | 12V RELAY          | 2   | 150           |
| 5.  | 12V TRANSFOMER     | 4   | 400           |
| 6.  | BUZZER             | 1   | 20            |
| 7.  | DIODE              | 5   | 20            |
| 8.  | CAPACITOR          | 5   | 30            |
| 9.  | RESISTER           |     | 20            |
| 10. | BC547 TRANSISTOR   | 3   | 20            |
| 11. | BD135 TRANSISTOR   | 2   | 20            |
| 12. | LED                |     | 30            |
| 13. | POWER SWITCH       | 1   | 20            |
| 14. | 7805 REGULATOR     | 1   | 30            |
| 15. | AC CORD            | 1   | 50            |
| 16. | PCB BOARD          | 1   | 100           |
| 17. | PROJECTS STRUCTURE | 1   | 300           |
| 18. | HEATER             | 1   | 200           |
| 19. | BOILER POT         | 1   | 100           |
| 20. | TANK POT           | 1   | 100           |
| 21. | 5V DC PUMP         | 2   | 300           |
| 22. | PUSH SWITCH        | 3   | 20            |
|     | <b>TOTAL PRICE</b> |     | <b>2640/-</b> |



### 3.4 Arduino Nano Microcontroller Board

#### 3.4.1 Defining Arduino Nano

An Arduino is actually a microcontroller-based kit which can be either used directly by purchasing from the vendor or can be made at home using the components, owing to its open-source hardware feature. It is basically used in communications and in controlling or operating many devices. It was founded by Massimo Banzi and David Cuartielles in 2005.



Figure 4. 1 Arduino NANO

#### 3.4.2 Arduino Architecture:

Arduino's processor basically uses the Harvard architecture where the program code and program data have separate memory. It consists of two memories- Program memory and the data memory. The code is stored in the flash program memory, whereas the data is stored in the data memory. The Atmega328 has 32 KB of flash memory for storing code (of which 0.5 KB is used for the bootloader), 2 KB of SRAM and 1 KB of EEPROM and operates with a clock speed of 16MHz.

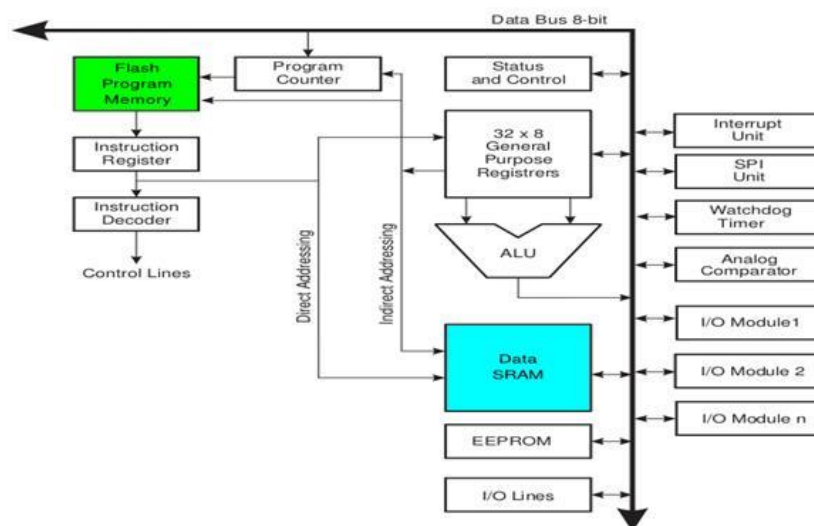

Figure 4. 2 Arduino Architecture:

### 3.4.3 Arduino Pin Diagram

A typical example of Arduino board is Arduino Uno. It consists of ATmega328- a 28 pin microcontrollers.

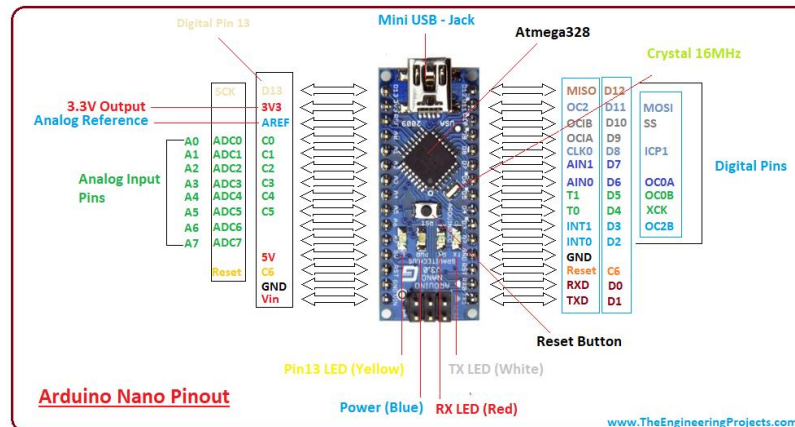

Figure 4.3: Arduino pin diagram

**Power Jack:** Arduino can be power either from the pc through a USB or through external source like adaptor or a battery. It can operate on a external supply of 7 to 12V. Power can be applied externally through the pin Vin or by giving voltage reference through the IOREf pin.

**Digital Inputs:** It consists of 14 digital inputs/output pins, each of which provide or take up 40mA current. Some of them have special functions like pins 0 and 1, which act as Rx and Tx respectively, for serial communication, pins 2 and 3-which are external interrupts, pins 3,5,6,9,11 which provides pwm output and pin 13 where LED is connected.

**Analog inputs:** It has 6 analog input/output pins, each providing a resolution of 10 bits.

**AREf:** It provides reference to the analog inputs

**Reset:** It resets the microcontroller when low.

### 3.4.4 How to program an Arduino?

The most important advantage with Arduino is the programs can be directly loaded to the device without requiring any hardware programmer to burn the program.

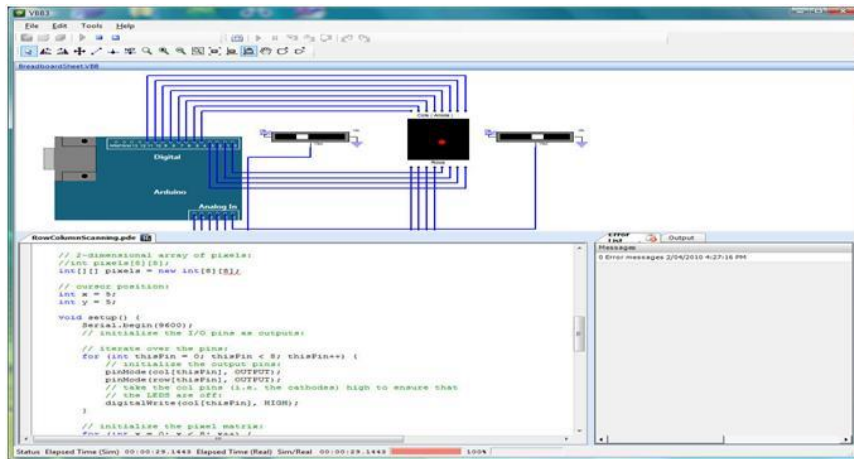

Figure 4. 4 Arduino programming process

This is done because of the presence of the 0.5KB of Bootloader which allows the program to be burned into the circuit. All we have to do is to download the Arduino software and writing the code.

The Arduino tool window consists of the toolbar with the buttons like verify, upload, new, open, save, serial monitor. It also consists of a text editor to write the code, a message area which displays the feedback like showing the errors, the text console which displays the output and a series of menus like the File, Edit, Tools

### 3.4.5 5 Steps to program an Arduino

Programs written in Arduino are known as sketches. A basic sketch consists of 3 parts

1. Declaration of Variables
2. Initialization: It is written in the setup () function.
3. Control code: It is written in the loop () function.

The sketch is saved with .ino extension. Any operations like verifying, opening a sketch, saving a sketch can be done using the buttons on the toolbar or using the tool menu.

The sketch should be stored in the sketchbook directory.

Chose the proper board from the tool's menu and the serial port numbers.

Click on the upload button or chose upload from the tool's menu. Thus, the code is uploaded by the bootloader onto the microcontroller.

### **3.4.6 Few of basic Arduino functions are:**

digital Read(pin): Reads the digital value at the given pin.

digital Write(pin, value): Writes the digital value to the given pin.

pin Mode(pin, mode): Sets the pin to input or output mode.

analog Read(pin): Reads and returns the value.

analog Write(pin, value): Writes the value to that pin.

serial. Begin(baud rate): Sets the beginning of serial communication by setting the bit rate.

### **3.4.7 How to Design your own Arduino?**

We can also design our own Arduino by following the schematic given by the Arduino vendor and also available at the websites. All we need are the following components- A breadboard, a led, a power jack, a IC socket, a microcontroller, few resistors, 2 regulators, 2 capacitors.

The IC socket and the power jack are mounted on the board.

Add the 5v and 3.3v regulator circuits using the combinations of regulators and capacitors.

Add proper power connections to the microcontroller pins.

Connect the reset pin of the IC socket to a 10K resistor.

Connect the crystal oscillators to pins 9 and 10

Connect the led to the appropriate pin.

Mount the female headers onto the board and connect them to the respective pins on the chip.

Mount the row of 6 male headers, which can be used as an alternative to upload programs.

Upload the program on the Microcontroller of the readymade Arduino and then pry it off and place back on the user kit.

### **3.4.8 7 Reasons why Arduino is being preferred these days**

#### **4.2.8a It is inexpensive**

It comes with an open-source hardware feature which enables users to develop their own kit using already available one as a reference source.

The Arduino software is compatible with all types of operating systems like Windows, Linux, and Macintosh etc.

It also comes with open-source software feature which enables experienced software

developers to use the Arduino code to merge with the existing programming language libraries and can be extended and modified.

#### 4.2.8a It is easy to use for beginners.

We can develop an Arduino based project which can be completely stand alone or projects which involve direct communication with the software loaded in the computer.

It comes with an easy provision of connecting with the CPU of the computer using serial communication over USB as it contains built in power and reset circuitry.

### 3.5 Power Supply

A power supply is an electronic device that supplies electric energy to an electrical load. The primary function of a power supply is to convert one form of electrical energy to another. As a result, power supplies are sometimes referred to as electric power converters. Some power supplies are discrete, stand-alone devices, whereas others are built into larger devices along with their loads. Examples of the latter include power supplies found in desktop computers and consumer electronics devices. The source of this power can come from different source like the main AC voltage, a battery or even from a renewable power source like solar panel wind turbine or fuel cell to name just a few. The most common source of power is usually the main AC

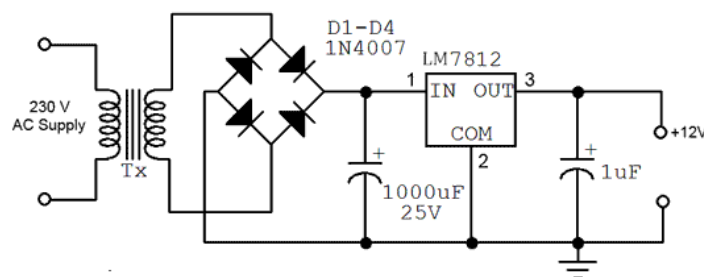

Figure 4. 5 AC-DC Power Supply & Circuit Diagram.

#### 3.5 .1 Transformer

A transformer is a device consisting of two closely coupled coils called primary and secondary coils. An AC voltage applied to the primary appears across the secondary with a voltage multiplication proportion to the turn ratio of the transformer and a current multiplication inversely proportional to the turn ratio power is conserved

turn ration =  $V_P/V_S = N_P/N_S$  and power out = power in or  $V_s$

### 3.5.2 Working of this Transformer

The two voltages, between line 1 and neutral and between neutral and line 2 can be named as  $V_A$  and  $V_B$  respectively.

Then the mathematical relation of these two voltages shows that they are dependent upon the primary voltage as well as the turn ration of the transformer.

Diagram of transformer

$$V_A = (N_A / N_P) * V_P$$

$$V_B = (N_B / N_P) * V_P$$

One thing that should be noted here is that both the outputs  $V_A$  and  $V_B$  respectively are equal in magnitude but opposite in direction, which means that they are 180 degrees out of phase with each other. For this purpose, we also use a full wave rectifier with a center tapped transformer, to make both the voltages in phase with each other.

### 3.6 Diode

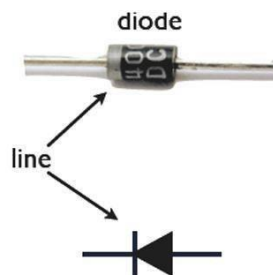

Figure 4. 6 Diode and symbol

The term diode usually implies a small signal device with current typically in the milliamp range. A semiconductor diode consists of a PN junction and has two (2) terminals, an anode (+) and cathode (-) current flows from anode to cathode within the diode. Diodes are semiconductor device that might be described as passing current in one direction only. The latter part of that statement applies equally vacuum tube diodes. Diodes however are far more extremely versatile in fact. Diode can be used as rectifier, voltage regulators, turning devices

in radio frequency tuned circuit, frequency multiplying device in radio frequency circuit, mixing devices application or can be used to make logic decision in digital circuit.

### 3.6.1 Characteristics curve of diode

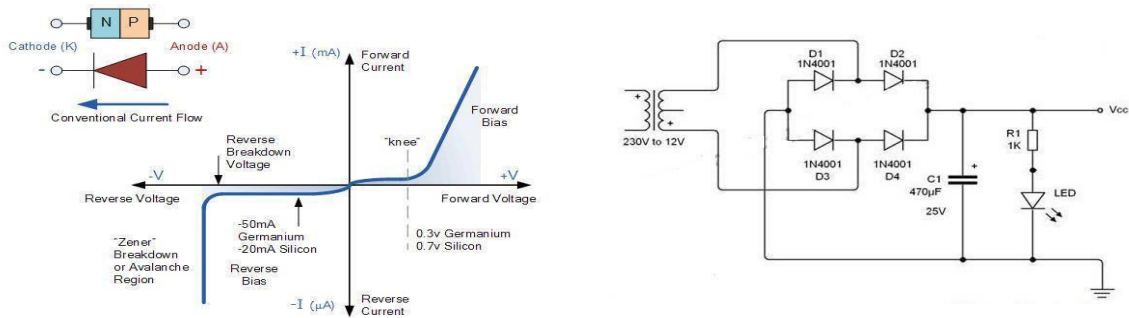

Figure 4. 7 Junction diode symbol and static I-V characteristics

There are two operating regions and three possible “biasing” conditions for the standard Junction Diode and these are:

1. Zero Bias – No external voltage potential is applied to the PN junction Diode
2. Reverse Bias – The voltage potential is connected negative, (-ve) to the P type material and positive, (+ve) to the N-type material across the diode which has the effect of Increasing the

PN junction diode’s width.

3. Forward Bias – The voltage potential is connected positive, (+ve) to the P type material and negative, (-ve) to the N-type material across the diode which has the effect of Decreasing the PN junction diodes width.

### 3.6.2 Full-Wave Rectifiers

A rectifier is an electronic circuit that converts AC voltage to DC voltage. It can be implemented using a capacitor diode combination. The unique property of diodes, permitting the current to flow in a single direction is utilized in here. It converts an ac voltage into a pulsating dc voltage using both half cycles of the applied ac voltage. Bridge rectifier is a full wave rectifier circuit using the combination of four diodes to form a bridge. It has the advantage that it converts both the half cycles of AC input into DC output.

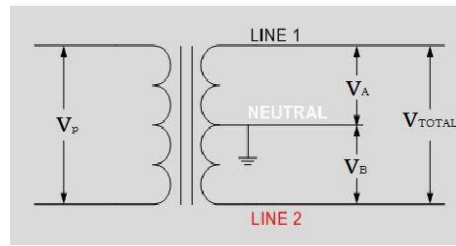

Figure 4. 8 Bridge rectifier circuit

### 3.6.3 Working of a Bridge Rectifier

- During the positive half cycle of secondary voltage, diodes D2 and D3 are forward biased and diodes D1 and D4 are reverse biased. Now the current flows through D2– >Load–>D3.
- During the negative half cycle of the secondary voltage, diodes D1 and D4 are forward biased and rectifier diodes D2 and D3 are reverse biased. Now the current flows through D4– >Load>D1.
- In both the cycles, load current flows in the same direction. Hence, we get a pulsating DC voltage as shown in fig (3.5,3.6).

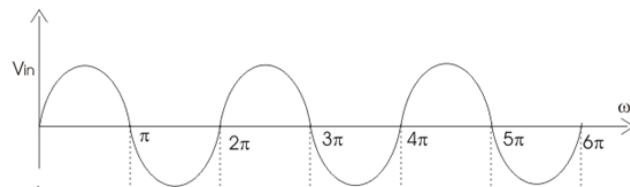

Figure 4.9 Input sine wave

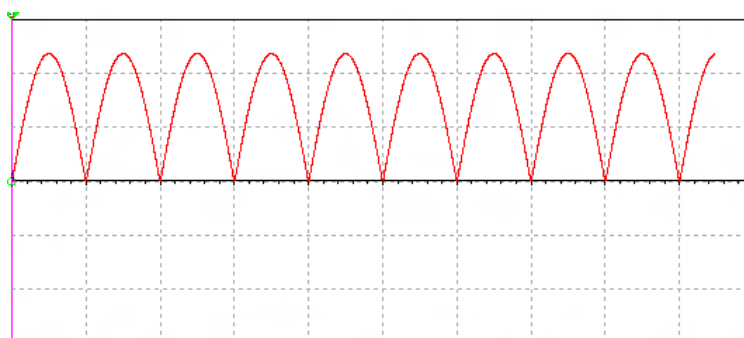

Figure 4. 9 Pulsating DC output



- Addition of a capacitor at the output converts the pulsating DC voltage to fixed DC voltage.
- Up to a time period of  $t=1s$  input voltage is increasing, so the capacitor charges up to peak value of the input. After  $t=1s$  input starts to decrease, then the voltage across the capacitor reverse biases the diodes D2 and D4 and therefore it will not conduct. Now capacitor discharges through the load, then voltage across the capacitor decreases.
- When the peak voltage exceeds the capacitor voltage, diodes D2 or D4 forward biases and as a result capacitor again charges to the peak value. This process continues. Hence, we get almost smooth DC voltage as shown in fig (3.7).

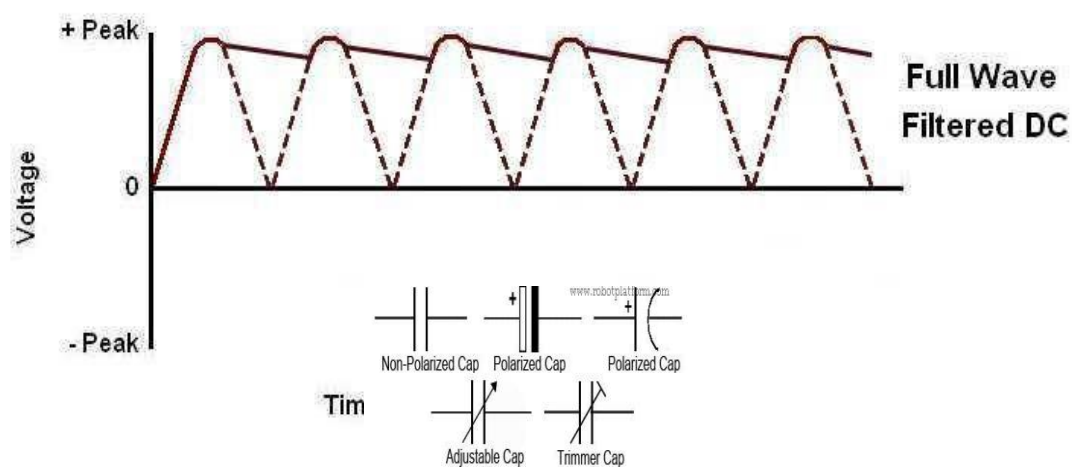

Fig. 3.10 Filtered output

### 3.7 Capacitor

Capacitor is a passive two-terminal electrical component used to store energy in an electric field. The forms of practical capacitors vary widely, but all contain at least two conductors separated by a non-conductor. Capacitors used as parts of electrical systems, for example consist of metal soils separated by a layer of insulating film. A capacitor is passive electronic component consisting of a pair of conductors separated by a dielectric (insulator) when there is a potential difference (voltage) across the detected on one plate and negative charge on the other plate. Energy is stored in the electrostatic field and is measured in farads.



Figure 4. 10 Capacitors & Capacitor symbols.

### 3.7.1 Theory of Operation

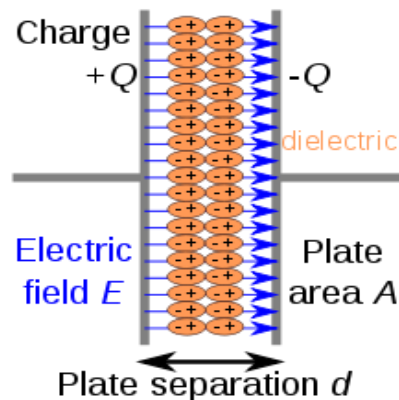

Figure 4. 11 Internal constriction of capacitors

A capacitor consists of two conductors separated by a non-conductive region. The non-conductive region is called the dielectric. In simpler terms, the dielectric is just an electrical insulator. Examples of dielectric media are glass, air, paper, vacuum, and even a semiconductor depletion region chemically identical to the conductors. A capacitor is assumed to be self-contained and isolated, with no net electric charge and no influence from any external electric field. The conductors thus hold equal and opposite charges on their facing surfaces, and the dielectric develops an electric field. In SI units, a capacitance of one farad means that one coulomb of charge on each conductor causes a voltage of one volt across the device.

An ideal capacitor is wholly characterized by a constant capacitance  $C$ , defined as the ratio of charge  $\pm Q$  on each conductor to the voltage  $V$  between them:

$$C=QV$$

Because the conductors (or plates) are close together, the opposite charges on the conductors attract one another due to their electric fields, allowing the capacitor to store more charge for a given voltage than if the conductors were separated, giving the capacitor a large capacitance.

Sometimes charge build-up affects the capacitor mechanically, causing its capacitance to vary. In this case, capacitance is defined in terms of incremental changes:

$$C=dQdV$$

### 3.8 Voltage Regulator

A voltage regulator is a system designed to automatically maintain a constant voltage level. A voltage regulator may use a simple feed-forward design or may include negative feedback. It may use an electromechanical mechanism, or electronic components.

#### 4.6.1 Voltage Regulators Output Voltages

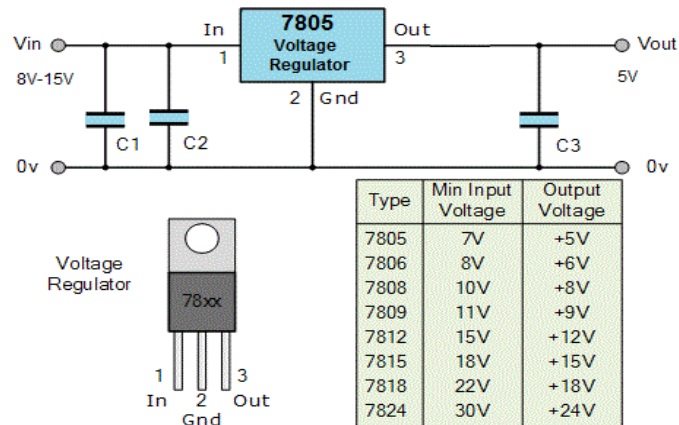

Figure 4. 12 Voltage regulator output voltages.

### 3.9 SIM 800L GSM MODULE

#### 3.9.1 Introduction:

This document describes SIM800L hardware interface in great detail. This document can help user to quickly understand SIM800L interface specifications, electrical and mechanical details. With the help of this document and other SIM800L application notes, user guide, users can use SIM800L to design various applications quickly

#### 3.9.2 SIM800L Overview:

SIM800L is a quad-band GSM/GPRS module, that works on frequencies GSM850MHz, EGSM900MHz, DCS1800MHz and PCS1900MHz. SIM800L features GPRS multi-slot class 12/ class 10 (optional) and supports the GPRS coding schemes CS-1, CS-2, CS-3 and CS-4.

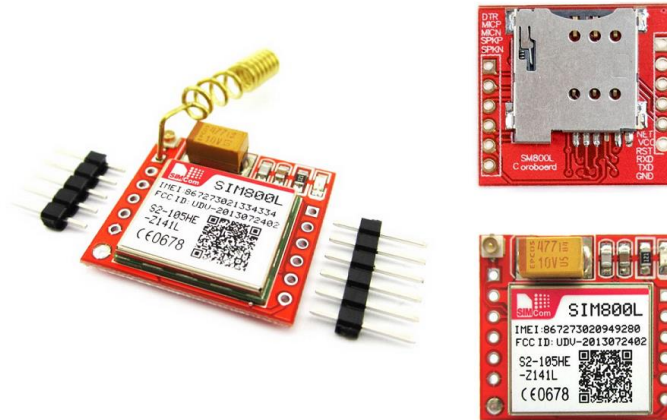

Figure 4.13 Overview of SIM800L GSM Module

With a tiny configuration of 15.8\*17.8\*2.4mm, SIM800L can meet almost all the space requirements in user applications, such as smart phone, PDA and other mobile devices.

SIM800L has 88pin pads of LGA packaging, and provides all hardware interfaces between the module and customers' boards.

- Support 5\*5\*2 keypads
- One full modem serial port, user can configure two serial ports
- One USB, the USB interfaces can debug, download software
- Audio channel which includes two microphone input; a receiver output and a speaker output
- Programmable general-purpose input and output.
- A SIM card interface
- Support FM
- Support one PWM

SIM800L is designed with power saving technique so that the current consumption is as low as 0.7mA in sleep mode.

### 3.9.3 SIM800L Key Features:

Table 1. Operating Mode

| Feature            | Implementation  |
|--------------------|---|
| Power supply       | 3.4V ~4.4V  |
| Power saving       | typical power consumption in sleep mode is 0.7mA (AT+CFUN=0 )   |
| Frequency bands    | <ul style="list-style-type: none"><li>• Quad-band: GSM 850, EGSM 900, DCS 1800, PCS 1900. SIM800L can search the 4 frequency bands automatically. The frequency bands can also be set by AT command “AT+CBAND”. For details, please refer to document[1].</li><li>• Compliant to GSM Phase 2/2+</li></ul> |
| Transmitting power | <ul style="list-style-type: none"><li>• Class 4 (2W) at GSM 850 and EGSM 900</li><li>• Class 1 (1W) at DCS 1800 and PCS 1900</li></ul>  |
| GPRS connectivity  | <ul style="list-style-type: none"><li>• GPRS multi-slot class 12 (default)</li><li>• GPRS multi-slot class 1~12 (option)</li></ul>  |
| Temperature range  | <ul style="list-style-type: none"><li>• Normal operation: -40°C ~ +85°C</li></ul>   |

|                            |   |
|----------------------------|---|
|                            | <ul style="list-style-type: none"> <li>Storage temperature -45°C ~ +90°C</li> </ul>   |
| Data GPRS                  | <ul style="list-style-type: none"> <li>GPRS data downlink transfer: max. 85.6 kbps</li> <li>GPRS data uplink transfer: max. 85.6 kbps</li> <li>Coding scheme: CS-1, CS-2, CS-3 and CS-4</li> <li>PAP protocol for PPP connects</li> <li>Integrate the TCP/IP protocol.</li> <li>Support Packet Broadcast Control Channel (PBCCH)</li> <li>CSD transmission rates : 2.4, 4.8, 9.6, 14.4 kbps</li> </ul>  |
| CSD                        | <ul style="list-style-type: none"> <li>Support CSD transmission</li> </ul>  |
| USSD                       | <ul style="list-style-type: none"> <li>Unstructured Supplementary Services Data (USSD) support</li> </ul>   |
| SMS                        | <ul style="list-style-type: none"> <li>MT, MO, CB, Text and PDU mode</li> <li>SMS storage: SIM card</li> </ul>  |
| SIM interface              | Support SIM card: 1.8V, 3V  |
| External antenna           | Antenna pad   |
| Audio features             | <p>Speech codec modes:</p> <ul style="list-style-type: none"> <li>Half Rate (ETS 06.20)</li> <li>Full Rate (ETS 06.10)</li> <li>Enhanced Full Rate (ETS 06.50 / 06.60 / 06.80)</li> <li>Adaptive multi rate (AMR)</li> <li>Echo Cancellation</li> <li>Noise Suppression</li> </ul>  |
| Serial port and debug port | <p><b>Serial port:</b></p> <ul style="list-style-type: none"> <li>Full modem interface with status and control lines, unbalanced, asynchronous.</li> <li>1200bps to 115200bps.</li> <li>Can be used for AT commands or data stream.</li> <li>Support RTS/CTS hardware handshake and software ON/OFF flow control.</li> <li>Multiplex ability according to GSM 07.10 Multiplexer Protocol.</li> <li>Autobauding supports baud rate from 1200 bps to 57600bps.</li> <li>upgrading firmware</li> </ul> <p><b>Debug Port</b></p> <ul style="list-style-type: none"> <li>USB_DM and USB_DP</li> <li>Can be used for debugging and upgrading firmware.</li> </ul> |
| Phonebook management       | Support phonebook types: SM, FD, LD, RC, ON, MC.  |
| SIM application toolkit    | GSM 11.14 Release 99  |
| Real time clock            | Support RTC   |
| Timing functions           | Use AT command set  |
| Physical characteristics   | <p>Size:15.8*17.8*2.4mm</p> <p>Weight:1.35g</p>   |
| Firmware upgrade           | Main serial port or USB port.   |

| Mode             | Function       |  |
|------------------|----------------|--|
| Normal operation | GSM/GPRS SLEEP | <p>Module will automatically go into sleep mode if the conditions of sleep mode are enabling and there is no on air and no hardware interrupt (such as GPIO interrupt or data on serial port).</p> <p>In this case, the current consumption of module will reduce to the minimal level.</p> <p>In sleep mode, the module can still receive paging message and SMS.</p> |
|                  | GSM IDLE       | <p>Software is active. Module is registered to the GSM network, and the module is ready to communicate.</p>  |
|                  | GSM TALK       | <p>Connection between two subscribers is in progress. In this case, the power consumption depends on network settings such as DTX off/on, FR/EFR/HR, hopping sequences, antenna.</p>   |
|                  | GPRS STANDBY   | <p>Module is ready for GPRS data transfer, but no data is currently sent or received. In this case, power consumption depends on network settings and GPRS configuration.</p>  |

Table 4. 1  
SIM800L  
Key Features:

Table 4. 2  
SIM800L  
function:

|                            |   |  |  |
|----------------------------|---|--|--|
|                            | GPRS DATA   | There is GPRS data transfer (PPP or TCP or UDP) in progress. In this case, power consumption is related with network settings (e.g. power control level); uplink/downlink data rates and GPRS configuration (e.g. used multi-slot settings). |  |
| Power down                 | Normal power down by sending AT command “AT+CPOWD=1” or using the PWRKEY. The power management unit shuts down the power supply for the baseband part of the module, and only the power supply for the RTC is remained. Software is not active. The serial port is not accessible. Power supply (connected to VBAT) remains applied.                                    |  |  |
| Minimum functionality mode | AT command “AT+CFUN” can be used to set the module to a minimum functionality mode without removing the power supply. In this mode, the RF part of the module will not work or the SIM card will not be accessible, or both RF part and SIM card will be closed, and the serial port is still accessible. The power consumption in this mode is lower than normal mode. |  |  |

| Coding scheme | 1 timeslot | 2 timeslot | 4 timeslot |
|---------------|------------|------------|------------|
| CS-1          | 9.05kbps   | 18.1kbps   | 36.2kbps   |
| CS-2          | 13.4kbps   | 26.8kbps   | 53.6kbps   |
| CS-3          | 15.6kbps   | 31.2kbps   | 62.4kbps   |
| CS-4          | 21.4kbps   | 42.8kbps   | 85.6kbps   |

[ref. 9]

#### 4.7.4 Coding schemes and maximum net data rates over air interface

The table below summarizes the various operating modes of SIM800L.

### 3.9.6 Functional Diagram

The following figure shows a functional diagram of SIM800L:

- GSM baseband
- GSM RF
- Antenna interface
- Other interface



### 3.9.7 Pin Description

Table 2 SIM800L Pin Description

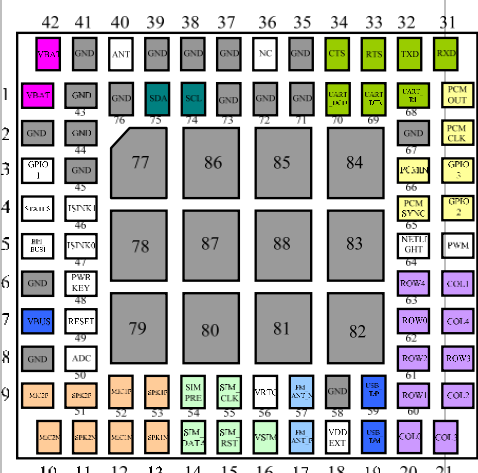
| Pin name  | Pin number  | I/O    | Description          | Comment   |
|---|---|--------|----------------------|---|
| <b>Power supply</b>   |   |        |                      |   |
| VBAT  | 1,42  | I      | Power supply         |   |
| VRTC  | 56  | I/O    | Power supply for RTC | It is recommended to use a capacitor (e.g., 4.7uF). |
| VEXT  | 18  | O      | 2.8V power output    | If these pins are unused, keep open.                |
|  <p><b>SIM800L pin out Diagram (Top view)</b></p> |   |        |                      |   |
| GND   | 2,6,8,35,37,38,39,41,43,44,45,58,67,71,72,73,76,77,79 | Ground | Ground               | GND for VBAT recommend to use 2,43,44,45pin         |

|                          |                       |   |  |   |
|--------------------------|-----------------------|---|--|---|
|                          | 8,79,80,81,82,83<br>, |   |  |   |
|                          | 84,85,86,87,88        |   |  |   |
| <b>Power on/down</b>     |                       |   |  |   |
| PWRKEY                   | 48                    | I | PWRKEY should be pulled low at least 1 second and then released to power on/down the module. | Internally pulled up to   |
| <b>Audio interfaces</b>  |                       |   |  |   |
| MIC1P                    | 52                    | I | Differential audio input   | If these pins are unused, keep open.  |
| MIC1N                    | 12                    |   |  |   |
| SPK1P                    | 53                    | O | Differential audio output  |   |
| SPK1N                    | 13                    |   |  |   |
| MIC2P                    | 9                     | I | Differential audio input   |   |
| MIC2N                    | 10                    |   |  |   |
| SPK2P                    | 51                    | O | Differential audio output  |   |
| SPK2N                    | 11                    |   |  |   |
| <b>PCM interface</b>     |                       |   |  |   |
| PCMCLK                   | 29                    | O | PCM interface for audio  | If these pins are unused, keep open.  |
| PCMOUT                   | 30                    | O |  |   |
| PCMSYNC                  | 65                    | O |  |   |
| PCMIN                    | 66                    | I |  |   |
| <b>Keypads interface</b> |                       |   |  |   |
| COL4                     | 24                    | I | Support up to 50 buttons (5*5*2)   | If these pins are unused, keep open. (Pin number 20 external cannot be pulled down) |
| COL3                     | 21                    | I |  |   |
| COL2                     | 22                    | I |  |   |
| COL1                     | 25                    | I |  |   |
| COL0                     | 20                    | I |  |   |
| ROW4                     | 63                    | O |  |   |
| ROW3                     | 23                    | O |  |   |

|                        |    |     |   |                                      |                                      |
|------------------------|----|-----|---|--------------------------------------|--------------------------------------|
| ROW2                   | 61 | O   |   |                                      |                                      |
| ROW1                   | 60 | O   |   |                                      |                                      |
| ROW0                   | 62 | O   |   |                                      |                                      |
| <b>GPIO</b>            |    |     |   |                                      |                                      |
| GPIO1                  | 3  | I/O | Programmable general-purpose input and output |                                      |                                      |
| GPIO2                  | 27 | I/O |   |                                      |                                      |
| GPIO3                  | 28 | I/O |   |                                      |                                      |
| NETLIGHT               | 64 | O   | Network status                                |                                      |                                      |
| STATUS                 | 4  | O   | Power on status                               |                                      |                                      |
| <b>Serial port</b>     |    |     |   |                                      |                                      |
| UART_DTR               | 69 | I   | Data terminal ready                           | If these pins are unused, keep open. |                                      |
| UART_RI                | 68 | O   | Ring indicator                                |                                      |                                      |
| UART_DCD               | 70 | O   | Data carrier detect                           |                                      |                                      |
| CTS                    | 34 | O   | Request to send                               |                                      |                                      |
| RTS                    | 33 | I   | Clear to send                                 |                                      |                                      |
| TXD                    | 32 | O   | Transmit data                                 |                                      |                                      |
| RXD                    | 31 | I   | Receive data                                  |                                      |                                      |
| <b>Debug interface</b> |    |     |   |                                      |                                      |
| VBUS                   | 7  | I   | Debug and download                            | If these pins are unused, keep open. |                                      |
| USB_DP                 | 59 | I/O |   |                                      |                                      |
| USB_DM                 | 19 | I/O |   |                                      |                                      |
| <b>ADC</b>             |    |     |   |                                      |                                      |
| ADC                    | 50 | I   | 10bit general analog converter                | digital                              | If these pins are unused, keep open. |

| <b>PWM</b>                        |    |         |   |  |
|-----------------------------------|----|---------|---|--|
| PWM                               | 26 | O       | Pulse-width modulation                                      | If these pins are unused, keep open.   |
| <b>I<sup>2</sup>C</b>             |    |         |   |  |
| SDA                               | 75 | I/<br>O | I <sup>2</sup> C serial bus data                            | Need external pulled up  |
| SCL                               | 74 | O       | I <sup>2</sup> C serial bus clock                           |  |
| <b>SIM card interface</b>         |    |         |   |  |
| VSIM                              | 16 | O       | Voltage supply for SIM card.<br>Support 1.8V or 3V SIM card | All signals of SIM interface should be protected against ESD with a TVS diode array. |
| SIM_DAT A                         | 14 | I/<br>O | SIM data input/output                                       |  |
| SIM_CLK                           | 55 | O       | SIM clock   |  |
| SIM_RST                           | 15 | O       | SIM reset   |  |
| SIMPRE                            | 54 | I       | SIM card detection  | Reservation function   |
| <b>Antenna interface</b>          |    |         |   |  |
| ANT                               | 40 | I/<br>O | Connect GSM antenna   |  |
| FM_ANT_P                          | 17 | I       | Differential antenna for FM                                 |  |
| FM_ANT_N                          | 57 | I       |   |  |
| <b>Synchronizing signal of RF</b> |    |         |   |  |

| BPI_BUS1     | 5  | O | Synchronizing signal of RF |  |
|--------------|----|---|----------------------------|--|
| <b>Other</b> |    |   |                            |  |
| RESET        | 49 | I | Reset input(Active low)    |  |
| ISINK1       | 46 | I | Drive keypad backlight     |  |
| ISINK0       | 47 | I | Drive LCD backlight        |  |
| <b>NC</b>    |    |   |                            |  |

|    |    |  |  |
|----|----|--|--|
| NC | 36 |  |  |
|----|----|--|--|

[ref. 9]

### 4.7.8 Power Supply

The power supply range of SIM800L is from 3.4V to 4.4V. Recommended voltage is 4.0V. The transmitting burst will cause voltage drop and the power supply must be able to provide sufficient current up to 2A. For the VBAT input, a bypass capacitor (low ESR) such as a 100  $\mu$ F is strongly recommended.

Increase the 33PF and 10PF capacitors can effectively eliminate the high frequency interference. A 5.1V/500mW Zener diode is strongly recommended, the diode can prevent chip from damaging by the voltage surge. These capacitors and Zener diode should be placed as close as possible to SIM800L VBAT pins.

Table 8: Recommended Zener diode

|   | Vendor  | Part number  | Power(watts) | Packages |
|---|---------|--------------|--------------|----------|
| 1 | On semi | MMSZ5231BT1G | 500mW        | SOD123   |
| 2 | Prisemi | PZ3D4V2H     | 500mW        | SOD323   |
| 3 | Prisemi | PZ5D4V2H     | 500mW        | SOD523   |
| 4 | Vishay  | MMSZ4689-V   | 500mW        | SOD123   |
| 5 | Crownpo | CDZ55C5V1SM  | 500mW        | 0805     |

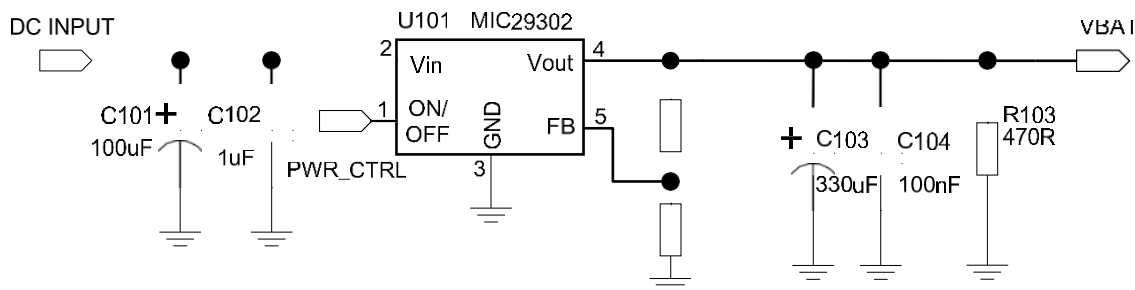

Figure 4. 14 Reference circuit of the DC-DC power supply

The following figure is the reference design of +5V input power supply. The designed output for the power supply is 4.1V, thus a linear regulator can be used.

R101  
100K

R102

The single 3.7V Li-ion cell battery can be connected to SIM800L VBAT pins directly. But the Ni-Cd or Ni-MH battery must be used carefully, since their maximum voltage can rise over the absolute maximum voltage of the module and damage it

When battery is used, the total impedance between battery and VBAT pins should be less than 150mΩ.

The following figure shows the VBAT voltage drop at the maximum power transmit phase, and the test condition is as following:

VBAT=4.0V,

A VBAT bypass capacitor  $C_A=100\mu\text{F}$  tantalum capacitor (ESR=0.7Ω), Another VBAT bypass capacitor  $C_B=1\mu\text{F}$ .

#### 4.7.9 Power supply pin

Pin 1 and Pin 42 are VBAT input, Pins 2,43,44,45 are GND of power supply, VRTC pin is power supply of the RTC circuit in the module. VDD\_EXT output 2.8V when module is in normal operation mode.

When designing the power supply in user's application, pay special attention to power losses. Ensure that the input voltage never drops below 3.0V even when current consumption rises to 2A in the transmit burst. If the power voltage drops below 3.0V, the module may be shut down automatically. The PCB traces from the VBAT pins to the power supply must be wide enough (at least 60mil) to decrease voltage drops in the transmit burst. The power IC and the bypass capacitor should be placed to the module as close as possible.

#### Monitoring Power Supply

AT command "AT+CBC" can be used to monitor the VBAT voltage. For detail, please refer to document [1].

#### Power on/down Scenarios

##### 3.9.9a Power on SIM800L

User can power on SIM800L by pulling down the PWRKEY pin for at least 1 second and release. This pin is already pulled up to VBAT in the module internal, so external pull up is not

necessary. Reference circuit is shown as below.

### 3.10 LCD Display

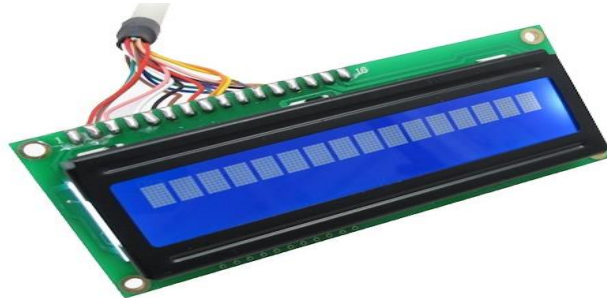

Figure 4. 15 16x2 LCD (Liquid Crystal Display)

LCD (Liquid Crystal Display) screen is an electronic display module. These modules are preferred over seven segments and other multi segment LEDs. LCDs are economical.

Construction and Working Principle of LCD Display

#### 3.10.1 What is a LCD (Liquid Crystal Display)?

A liquid crystal display or LCD draws its definition from its name itself. It is combination of two states of matter, the solid and the liquid. LCD uses a liquid crystal to produce a visible image. Liquid crystal displays are super-thin technology display screen that are generally used in laptop computer screen, TVs, cell phones and portable video games. LCD's technologies allow displays to be much thinner when compared to cathode ray tube (CRT) technology.

Liquid crystal display is composed of several layers which include two polarized panel filters and electrodes. LCD technology is used for displaying the image in notebook or some other electronic devices like mini computers. Light is projected from a lens on a layer of liquid crystal. This combination of colored light with the grayscale image of the crystal (formed as electric current flows through the crystal) forms the colored image. This image is then displayed on the screen.

An LCD is either made up of an active-matrix display grid or a passive display grid. Most of the Smartphone's with LCD display technology uses active-matrix display, but some of the older

displays still make use of the passive display grid designs. Most of the electronic devices mainly depend on liquid crystal display technology for their display. The liquid has a unique advantage of having low power consumption than the LED or cathode ray tube.

Liquid crystal display screen works on the principle of blocking light rather than emitting light. LCD's requires backlight as they do not emit light by them. We always use devices which are made up of LCD's displays which are replacing the use of cathode ray tube. Cathode ray tube draws more power compared to LCD's and are also heavier and bigger.

### 3.10.1 How LCDs are Constructed?

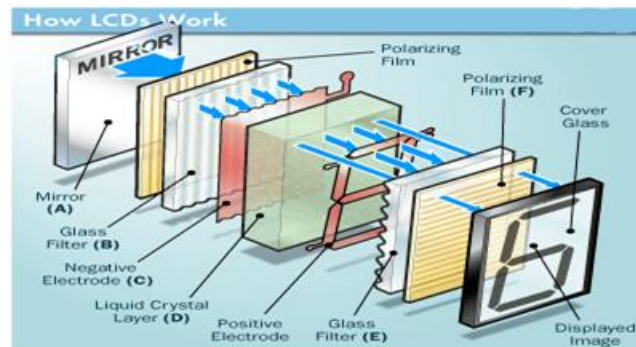

Figure 4. 16 Simple facts that should be considered while making an LCD:  
The basic structure of LCD should be controlled by changing the applied current.  
We must use a polarized light.  
Liquid crystal should be able to control both of the operation to transmit or can also be able to change the polarized light.  
As mentioned above that we need to take two polarized glass pieces' filter in the making of the liquid crystal. The glass which does not have a polarized film on the surface of it must be rubbed with a special polymer which will create microscopic grooves on the surface of the polarized glass filter. The grooves must be in the same direction of the polarized film. Now we have to add a coating of pneumatic liquid phase crystal on one of the polarized filters of the polarized glass. The microscopic channel causes the first layer molecule to align with filter orientation. When the



right angle appears at the first layer piece, we should add a second piece of glass with the polarized film. The first filter will be naturally polarized as the light strikes it at the starting stage.

Thus, the light travels through each layer and guided on the next with the help of molecule. The molecule tends to change its plane of vibration of the light in order to match their angle. When the light reaches to the far end of the liquid crystal substance, it vibrates at the same angle as that of the final layer of the molecule vibrates. The light is allowed to enter into the device only if the second layer of the polarized glass matches with the final layer of the molecule.

### **3.10.2 How LCDs Work?**

The principle behind the LCD's is that when an electrical current is applied to the liquid crystal molecule, the molecule tends to untwist. This causes the angle of light which is passing through the molecule of the polarized glass and also cause a change in the angle of the top polarizing filter. As a result, a little light is allowed to pass the polarized glass through a particular area of the LCD. Thus, that particular area will become dark compared to other. The LCD works on the principle of blocking light. While constructing the LCD's, a reflected mirror is arranged at the back. An electrode plane is made of indium-tin oxide which is kept on top and a polarized glass with a polarizing film is also added on the bottom of the device. The complete region of the LCD has to be enclosed by a common electrode and above it should be the liquid crystal matter.

Next comes to the second piece of glass with an electrode in the form of the rectangle on the bottom and, on top, another polarizing film. It must be considered that both the pieces are kept at right angles. When there is no current, the light passes through the front of the LCD it will be reflected by the mirror and bounced back. As the electrode is connected to a battery the current from it will cause the liquid crystals between the common-plane electrode and the electrode shaped like a rectangle to untwist. Thus, the light is blocked from passing through. That particular rectangular area appears blank.

#### **4.8.2a Advantages of an LCD's:**

- LCDs consumes less amount of power compared to CRT and LED
- LCDs are consisting of some microwatts for display in comparison to some mill watts for LED's

- LCDs are of low cost
- Provides excellent contrast
- LCDs are thinner and lighter when compared to cathode ray tube and LED

### **3.10.2b Disadvantages of an LCD's:**

- Require additional light sources
- Range of temperature is limited for operation
- Low reliability
- Speed is very low
- LCD's need an AC drive

### **3.10.3 Applications of Liquid Crystal Display**

- Liquid crystal technology has major applications in the field of science and engineering as well on electronic devices.
- Liquid crystal thermometer
- Optical imaging
- The liquid crystal display technique is also applicable in visualization of the radio frequency waves in the waveguide
- Used in the medical applications

## **3.11 Relay**

Definition: The relay is the device that open or closes the contacts to cause the operation of the other electric control. It detects the intolerable or undesirable condition with an assigned area and gives the commands to the circuit breaker to disconnect the affected area. Thus protects the system from damage.

Working Principle of Relay

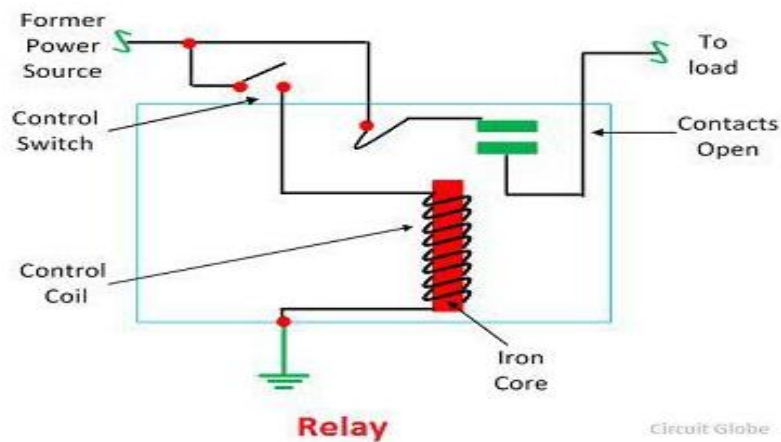

It works on the principle of an electromagnetic attraction. When the circuit of the relay senses the fault current, it energizes the electromagnetic field which produces the temporary magnetic field.

This magnetic field moves the relay armature for opening or closing the connections. The small power relay has only one contacts, and the high-power relay has two contacts for opening the switch.

The inner section of the relay is shown in the figure below. It has an iron core which is wound by a control coil. The power supply is given to the coil through the contacts of the load and the control switch. The current flows through the coil produces the magnetic field around it.

Due to this magnetic field, the upper arm of the magnet attracts the lower arm. Hence close the circuit, which makes the current flow through the load. If the contact is already closed, then it moves oppositely and hence open the contacts.

### 3.11.1 Pole and Throw

The pole and throws are the configurations of the relay, where the pole is the switch, and the throw is the number of connections. The single pole, the single throw is the simplest type of relay which has only one switch and only one possible connection. Similarly, the single pole double throw relay has a one switch and two possible connections.

### 3.11.2 Construction of Relay

The relay operates both electrically and mechanically. It consists electromagnetic and sets of contacts which perform the operation of the switching. The construction of relay is mainly classified into four groups. They are the contacts, bearings, electromechanical design, terminations and housing.

**3.11.2 Contacts** – The contacts are the most important part of the relay that affects the reliability. The good contact gives limited contact resistance and reduced contact wear. The selection of the contact material depends upon the several factors like nature of the current to be interrupted, the magnitude of the current to be interrupted, frequency and voltage of operation.

**3.11.3 Bearing** – The bearing may be a single ball, multi-ball, pivot-ball and jewel bearing. The single ball bearing is used for high sensitivity and low friction. The multi-ball bearing provides low friction and greater resistance to shock.

**3.11.4 Electromechanical design** – The electromechanical design includes the design of the magnetic circuit and the mechanical attachment of core, yoke and armature. The reluctance of the magnetic path is kept minimum for making the circuit more efficient. The electromagnet is made up of soft iron, and the coil current is usually restricted to 5A and the coil voltage to 220V.

**3.11.5 Terminations and Housing** – The assembly of an armature with the magnet and the base is made with the help of spring. The spring is insulated from the armature by moulded blocks which provide dimensional stability. The fixed contacts are usually spot welded on the terminal link.

### **3.11.6 How relays work**

When power flows through the first circuit (1), it activates the electromagnet (brown), generating a magnetic field (blue) that attracts a contact (red) and activates the second circuit (2). When the power is switched off, a [spring](#) pulls the contact back up to its original position, switching the second circuit off again.

This is an example of a "normally open" (NO) relay: the contacts in the second circuit are not connected by default, and switch on only when a current flows through the magnet. Other relays are "normally closed" (NC; the contacts are connected so a current flow through them by default) and switch off only when the magnet is activated, pulling or pushing the contacts apart. Normally open relays are the most common.

Here's another animation showing how a relay links two circuits together. It's essentially the same thing drawn in a slightly different way. On the left side, there's an input circuit powered by a switch or a sensor of some kind. When this circuit is activated, it feeds current to an electromagnet that pulls a metal switch closed and activates the second, output circuit (on the right side). The relatively small current in the input circuit thus activates the larger current in the output circuit

1. The input circuit (blue loop) is switched off and no current flows through it until something (either a sensor or a switch closing) turns it on. The output circuit (red loop) is also switched off.
2. When a small current flows in the input circuit, it activates the electromagnet (shown here as a dark blue coil), which produces a magnetic field all around it.

3. The energized electromagnet pulls the metal bar in the output circuit toward it, closing the switch and allowing a much bigger current to flow through the output circuit.
4. The output circuit operates a high-current appliance such as a lamp or an electric motor.

[ref. 9]

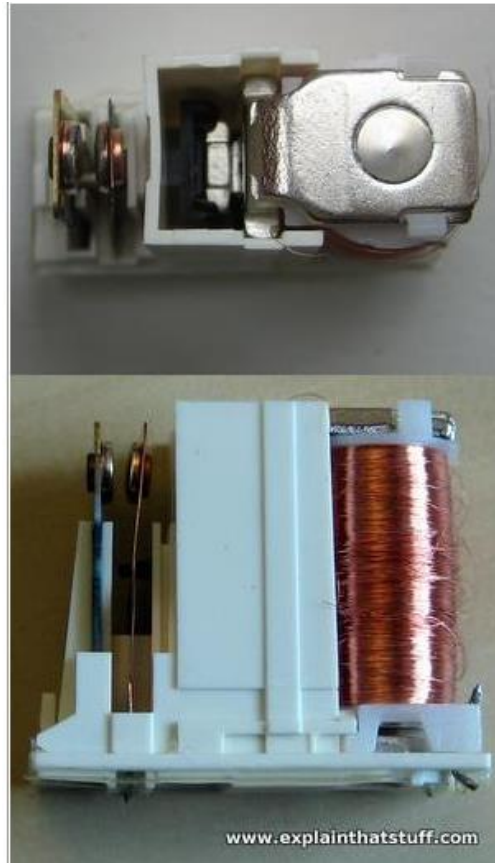

## Chapter 4

### Result and Discussion

#### 4.1 Result:

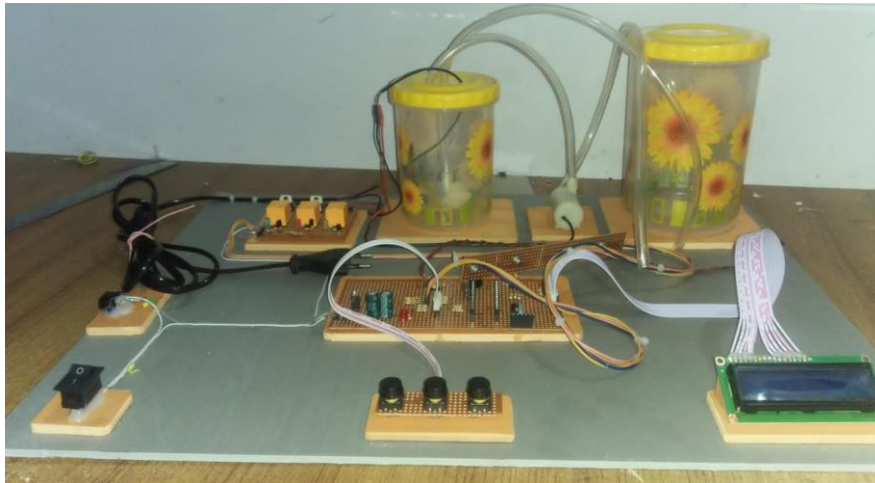

Finally, we were able to create our project successfully. After making the Mechanical body, we designed a circuit to control it and when we operated it with mobile apps, we called it working pretty well. It is very well controlled and is again able to clean the drain dirt very well. Below is a picture of our successfully completed entire project.

Figure 4.1.1: Complete Project Picture.

#### 4.2 Discussion:

From the above displayed figures, we can observe that the temperature monitoring & control portion as well as the level control portion is simulated successfully in MATLAB and also using C-Program. The temperature monitoring & control portion is also experimentally verified using a prototype model.

### **4.3 FUTURE SCOPES**

Fuzzy logic is a very emerging intelligent control method which can be applied successfully in nonlinear as well as in linear systems. Till now the conventional controllers like PID controllers are used in boiler temperature control applications but it has some disadvantages and errors when there is variation of load and nonlinearity arises in the system. But intelligent control system like fuzzy control works efficiently under these environments and can be easily implemented as observed in the experiment performed on the prototype model and using more ranged temperature sensors and level indicators and more powerful microcontrollers it can be implemented easily in industrial boiler and other steam temperature control applications as well as in other temperature and water level control applications

## Chapter 5

### Conclusion

#### 5.1 Advantages:

- Production cost is very low.
- No need of purchase special machine.
- Its operated and maintenance is simple.
- It can be efficiently used.
- Totally wireless controlled.
- No Need for External Energy Sources
- Can be Used in Tall Buildings
- Cleaning and Maintenance is Simple
- Additions Can Easily Be Made

#### 5.2 Applications:

This device finds place in.

- Still factory
- Garments factory
- Cement factory
- Ceramic factory
- And other factories where used boiler to produce energy



### **5.3 Conclusion:**

The boiler liquid level control system is designed based on the King view configuration software. The industrial control computer is used as host controller of the control system. The programmable logic controller (PLC) is used as slave controller of the control system. The normalized PID has been introduced for control algorithm. This method has the advantage of simplicity and is easy to implement. The results of the experiment and simulation show the design of system is feasible and effective.

The fuzzy logic based boiler temperature monitoring & control and Water level control inside the boiler chamber is simulated successfully and also the temperature monitoring & control portion is experimented successfully using a prototype model and the results are also verified. So, we can conclude that the fuzzy logic based boiler temperature and level control is working properly and the results obtained are very promising and satisfactory.

### **5.4 Future Scope:**

- In future we can developed this boiler system for any industry
- In future It's can help us to easily control the any type of boiler.

## REFERENCES

- [1] [https://en.wikipedia.org/wiki/PID\\_controller](https://en.wikipedia.org/wiki/PID_controller)
- [2] Qingbao Huang, Shaojian Song, Xiaofeng Lin, Kui Peng. “Research on Water Level Optimal Control of Boiler Drum Based on Dual Heuristic Dynamic Programming,” *Lecture Notes in Computer Science* 2011,6675:455-463.
- [3] Tan W, Liu J, Fang F, et al. “Tuning of PID controllers for boiler-turbine units,” *ISA transactions*, 2004, 43(4): 571-583.
- [4] [3] Yao Y P, Shi Y, Fei J Y. “Application of Configuration Technology in Traffic Light Control System Based on PLC,” *Applied Mechanics and Materials*, 2012, 151: 510-513.
- [5] Qiu Na, Li Yingying. “Configuration Software-based Monitoring System of the Boiler,” *Boiler Manufacturing*, 2012, (1):44-47
- [6] LiDa-wei, Duan Da-wei. “A Configuration Software-Based Supervisory System,” *Techniques of Automation and Applications*, 2009, 28(5):9395.
- [7] S. G. Dukelow, *The Control of Boilers*, 2nd ed., United States of America: Instrumentation Society of America, 1991.
- [8] B. G. Liptak, *Process Control and Optimization*, 4th ed., United States of America: Taylor and Francis Group, 2006.
- [9] G. F. Gilman, *Boiler Control System Engineering*, 1st ed., United States of America: The Instrumentation, Systems and Automation Society, 2005.
- [10] E. Peterschmidt, and M. Taylor, “Boilers and Boiler Control Systems,” in *Taylor & Francis*, paper 7.2.8, p. 93.
- [11] B. Stanmore, and M. Desai, “Steam Explosions in Boiler Ash Hoppers,” in *Proceedings of the Institution of Mechanical Engineers*, paper 1993, p. 133.
- [12] *Boiler Operation and Combustion Systems Hazards Code*, NFPA Std. 85, 2011.
- [13] *ASME Boiler and Pressure Vessel Code with Addenda*, ASME Std., 2010.
- [14] *Fossil Fuel Power Plant Steam Turbine Bypass System*,

## Appendix

```
#include<LiquidCrystal.h>
```

```
#Define BUZ 13
```

```
#Define PUMPin 4
```

```
#Define PUMPout 3
```

```
#Define HEATER 5
```

```
#Define LEVAP A3
```

```
#Define LEVBP A2
```

```
#Define LEVCP A1
```

```
#Define UP_PIN A5
```

```
#Define DN_PIN A6
```

```
#Define SET_PIN A7
```

```
int temp=0,  
i=0,cnt,cnt1,TF=0,SEC,MIN,HR,MSGF1,MSGF2,HON=90,HOF=95,BUZF=0,RLF=0,LEV,LE  
VA,LEVBP,LEVCP,Tf,Tc;
```

```
void setup ()
```

```
{
```

```
pinMode(LEVAP,INPUT);
```

```
pinMode(LEVBP,INPUT);
```

```
pinMode(LEVCP,INPUT);
```

```
pinMode(UP_PIN,INPUT);
```

```
pinMode(DN_PIN,INPUT);  
pinMode(SET_PIN,INPUT);
```

```
pinMode(PUMPIn, OUTPUT);  
pinMode(PUMPout, OUTPUT);  
pinMode(BUZ, OUTPUT);
```

```
lcd.setCursor(0,0);  
lcd.print("WELCOME TO ");  
lcd.setCursor(0,1);  
lcd.print(" su ");  
digitalWrite(BUZ, LOW);  
delay (1500);
```

```
lcd.setCursor(0,0);  
lcd.print(" SUBMITTED BY: ");  
lcd.setCursor(0,1);  
lcd.print(" mokarram ");  
delay (1500);
```

```
lcd.setCursor(0,0);  
lcd.print(" DEBASISH ");  
lcd.setCursor(0,1);  
lcd.print(" ");  
delay (2500);
```

```
digitalWrite(BUZ, LOW);  
delay (60);  
digitalWrite(BUZ, HIGH);  
delay (60);
```

```
digitalWrite(BUZ, LOW);
delay (60);
digitalWrite(BUZ, HIGH);
delay (60);
digitalWrite(BUZ, LOW);
delay (500);

lcd.print("Circuit Digest ");
delay (500);
lcd.setCursor(0,1);
lcd.print("System Ready... ");
```

```
SendMessage();
```

```
}
```

```
////////////////////////////////////
```

```
////////////////////////////////////
```

```
void loop ()
```

```
{
```

```
Temperature ();
```

```
LOAD_CONTROL ();
```

```
////////////////////////////////////
```

```
LEVA= digital Read (LEVAP);
```

```
LEVB= digital Read (LEVBP);
```

```
LEVC= digital Read (LEVCP);
```

```
if (LEVA==1)
```

```
LEV=10;
```

```
if (LEVA==0)
```

```
LEV=20;
```

```
if (LEVB==0)
```

```

LEV=60;
if (LEVC==0)
LEV=100;

DISPLAY1();

////////////////////////////////////
}
////////////////////////////////////
////////////////////////////////////
void Temperature ()
{
Tc = analog Read (A0);
Tf = (Tc * 9.0)/ 5.0 + 32.0;
}
////////////////////////////////////
////////////////////////////////////

void DISPLAY1()
{
lcd.setCursor(0, 0);
lcd.print("LEV:");
lcd.print(LEV);
lcd.print("% ");
lcd.print(HON);

lcd.setCursor(0, 1);
lcd.print("T:");
lcd.print(Tf);
lcd.write(0xdf); // for dgree sign
lcd.print("F ");

```

```

    lcd.print(HOF);
}
////////////////////////////////////////////////////////////////
////////////////////////////////////////////////////////////////

void check ()
{
    if (! (strcmp(str,"p1on",4)))
    {
        digitalWrite(PUMPin,HIGH);
        SendMessage1();
    }
    if (! (strcmp(str,"p1off",5)))
    {
        digitalWrite(PUMPin,LOW);
        SendMessage2();
    }
    if (! (strcmp(str,"p2on",4)))
    {
        digitalWrite(PUMPout,HIGH);
        SendMessage3();
    }
    if (! (strcmp(str,"p2off",5)))
    {
        digitalWrite(PUMPout,LOW);
        SendMessage4();
    }
    if (! (strcmp(str,"HON",3)))
    {
        digitalWrite(HEATER,HIGH);
        SendMessage3();
    }
}

```

```

}
if (! (strcmp(str,"HOFF",4)))
{
    digitalWrite(HEATER,LOW);
    SendMessage4();
}
if (! (strcmp(str,"WLEV",4)))
{
    SendMessage4();
}
if (! (strcmp(str,"TP",2)))
{
    SendMessage5();
}
}
////////////////////////////////////

////////////////////////////////////

void SendMessage()
{

Serial.println("AT+CMGS=\"+88017788\"\\r");
Serial.println("SYSTEM READY...");

}

void SendMessage1()
{
Serial.println("AT+CMGS=\"+8801680657376\"\\r");
Serial.println("PUMP-IN ON");
}

void SendMessage2()

```



```

{
Serial.println("AT+CMGS="+8801680657376+"\r");
Serial.println("PUMP-IN OFF");
}
void SendMessage3()
{
Serial.println("AT+CMGS="+8801680657376+"\r");
Serial.println("PUMP OUT ON");
}
void SendMessage4()
{
Serial.println("AT+CMGS="+8801680657376+"\r");
Serial.println("PUMP OUT OFF");
}
void SendMessage5()
{
Serial.println("AT+CMGS="+8801680657376+"\r");
Serial.println(Tf);
}

```

```

////////////////////////////////////
////////////////////////////////////

```

```

void LOAD_CONTROL ()
{
if (LEV==10)
digitalWrite(PUMPIn, HIGH);
if (LEV==100)
digitalWrite(PUMPIn, LOW);

if (Tf > HOF)
{

```

```
digitalWrite (HEATER, LOW);
```

```
digitalWrite (BUZ, HIGH);
```

```
}
```

```
if (Tf < HON)
```

```
{
```

```
digitalWrite (HEATER, HIGH);
```

```
}
```

```
}
```

```
////////////////////////////////////
```