



UGC & Govt. Approved  
**Sonargaon University (SU)**  
সোনারগাঁও ইউনিভার্সিটি (এসইউ)

## **Design And Construction Of A Solar Based Automatic Drain Cleaner System**

A Project

By

Md. Rana Ahmed	ID: BME 1903019151
Md. Alamin	ID: BME 1903019035
Md. Porag Ahmed	ID: BME 1903019209
Md. Jahangir Alom	ID: BME 1901017112
Md. Sahidul Islam	ID: BME 1903019313
Kabid hasan	ID: BME 1803016065

Supervisor

Istiaque Zahur

Lecturer

Department of Mechanical Engineering

Sonargaon University (SU)

Dhaka-1215, Bangladesh

# **A Solar Based Automatic Drain Cleaner System**

Submitted by

Md. Rana Ahmed	ID: BME 1903019151
Md. Alamin	ID: BME 1903019035
Md. Porag Ahmed	ID: BME 1903019209
Md. Jahangir Alom	ID: BME 1901017112
Md. Sahidul Islam	ID: BME 1903019313
Kabid Hasan	ID: BME 1803016065



Istiaque Zahur

Lecturer

SUBMITTED TO

Department of Mechanical Engineering

SONARGAON UNIVERSITY (SU)

In partial fulfillment of the requirement for award of the degree

Of

Bachelor of Science in Mechanical Engineering

May, 2023

## LETTER OF TRANSMITTAL

May, 2023

To

Istiaque Zahur

Lecturer

Department of Mechanical Engineering.

Sonargaon University

Subject: Submission of Project Report.

Dear Sir,

We are pleased to submit the project report on “**Design and Development of a Solar Based Automatic Drain Cleaner System**

". It was a great pleasure to work on such an important topic. This project has been done as per instruction of your supervision and according to the requirements of the Sonargaon University.

We expect that the project will be accepted by the concerned authority we will remain happy to further explanation that you may feel necessary in this regard.

Thank You

Sincerely yours,

Md. Rana Ahmed

ID: BME 1903019151

Md. Jahangir Alom

ID: BME 1901017112

Md. Alamin

ID: BME 1903019035

Md. Sahidul Islam

ID: BME 1903019313

Md. Porag Ahmed

ID: BME 1903019209

Kabid Hasan

ID: BME 1803016065

## DECLARATION

We do here by solemnly declare that, the work presented here in this project report has been carried out by us and has not been previously submitted to any University/ Organization for award of any degree or certificate

We hereby ensure that the works that has been prevented here does not breach any existing copyright.

We further undertake to indemnify the university against any loss or damage arising from breach of the foregoing obligation.

Md. Rana Ahmed

ID: BME 1903019151

Md. Jahangir Alom

ID: BME 1901017112

Md. Alamin

ID: BME 1903019035

Md. Sahidul Islam

ID: BME 1903019313

Md. Porag Ahmed

ID: BME 1903019209

Kabid Hasan

ID: BME 1803016065

## ACKNOWLEDGEMENT

First, we started in the name of almighty Allah. This thesis is accomplished under the supervision of Istiaque Zahur, Lecturer, Department of Mechanical, Sonargaon University. It is a great pleasure to acknowledge our profound gratitude and respect to our supervisor for this consistent guidance, encouragement, helpful suggestion, constructive criticism and endless patience through the progress of this work. The successful completion of this thesis would not have been possible without his persistent motivation and continuous guidance.

The authors are also grateful to Md. Mostofa Hossain, Head of the Department of Mechanical Engineering and all respect teachers of the Mechanical Engineering Department for their co-operation and significant help for completing the thesis work successfully.

## ABSTARCT

In this project the proposed concept is to replace the manual work in drainage cleaning by automated system controlled by micro-controller. Now-a-days even though automation plays a vital role in all industrial applications in the proper disposal of sewage from industries and commercials are still a challenging task. Drainage pipes are using for the disposal and unfortunately sometimes there may be loss of human life while cleaning the blockages in the drainage pipes. To overcome this problem and to save human life we implement a design and construction of a Solar Based Automatic Drain Cleaner System . We designed our project to use this in efficient way to control the disposal of wastage's and with regular filtration of wastage's, clearance of gaseous substance are treated separately and monitor the disposal in frequent manner.

## TABLE OF CONTENTS

Letter of Transmittal	ii
Declaration	iii
Acknowledgement	iv
Abstract	v
Table of Contents	vi
Table of Figure	viii
CHAPTER-1	INTRODUCTION
1.1 Introduction	01
1.2 Background Study	02
1.3 Problem Statement	02
1.4 Objective	03
1.5 Structure of the Projects	03
CHAPTER 2	LITERATURE REVIEW
2.1 Introduction	05
2.2 Literature Review	05
2.3 Summary	08
CHAPTER-3	HARDWARE AND SOFTWARE ANALYSIS
3.1 DC Gear Motor	09
3.2 Solar Panel	10
3.3 Solar Charge Controller	12
3.3 12V Battery	13
3.4 Smoothing Capacitor	14
3.5 Resistor	16
3.6 Easy EDA Software	17
CHAPTER-4	METHODOLOGY
4.1 Methodology	19

4.2	Structural Design	19
4.3	Block Diagram	20
4.4	Schematic Diagram	20
4.5	Working Principle	21
4.6	Our Final Project View	21
CHAPTER-5		RESULT AND DISCUSSION
5.1	Discussion	22
5.2	Result	22
5.3	Advantage	22
5.4	Application	23
CHAPTER-6		CONCLUSION
6.1	Conclusion	24
6.2	Future Scope	24
	Reference	25



## LIST OF FIGURES

FIGURE NO	FIGURE NAME	PAGE NO
3.1	DC Gear Motor	09
3.2	Solar Panel	10
3.3	Picture of solar cell system	11
3.4	Solar Panel Schema diagram	12
3.5	Solar Cell System Curve	12
3.6	Solar Charge controller	13
3.7	12V Battery	14
3.8	Capacitor	15
3.9	The Smoothing Capacitor with Full Bridge Rectifier	16
3.10	Resistor	16
3.11	Easy EDA Software Interface	18
4.1	Our Project Structural View	19
4.2	Block Diagram	20
4.3	Schematic Diagram	20
4.4	Our Final System Overview	21

# CHAPTER 1

## INTRODUCTION

### 1.1 Introduction

1. The proper disposal of common wastes is still a challenge faced nowadays, even though automation plays a vital role in the industrial and commercial applications. Usually what we see in a country like India is that common wastes like plastic bottles, covers, sanitary pads, etc and others are left in the streets and in the open drains. These waste particles obviously cause blockage of the drainage system during monsoon season when there is a flow of water through the roads and drainage systems. Also where the closed drainage system open near a river causes the pollution of river. This blockage of drainage system can cause accumulation of waste water in these drains.

2. Several water borne diseases such as cholera, worm disease, typhoid, malaria etc will occur due to the contamination of these stagnant water. This can cause many health issues and may even lead to deaths, other than the local common issues caused by the blockage of drainage. In India, there is no existing automated mechanism by which this blockage of drainage can be removed. Currently these blocked drains are cleared with the help of manual workers were the workers have to get into the drains and manually remove the wastes. In such situations the rate of diseases spread among these workers are high and this affects their life's and reduces their immunity.

3. Since the world is fast approaching towards the technology of digitalization and automation, humans want every task and operations to be performed quickly and easily. Now the time is for advanced techniques which can perform tasks efficiently and with minimum time. The human wants to apply minimum effort in order to accomplish its tasks. To achieve this there has to be automated techniques which can fulfill these objectives. Hence in this project we tried to add this automation technology with the knowledge of drainage systems in order to make the drainage cleaning system easy and efficient tool for the cleaning of the drainage systems and hence save the environment. For this we are using system by which drainage cleaner can do his work smartly using communication through application.

4. The problem of the sewage disposal coming from the industries is growing rapidly day by day and thus it needs to be resolved urgently since this problem is causing various environmental issues and is very harmful to the human life. This is a real time problem and it needs to be resolved and overall speaking this proposed concept is very much efficient in this work to be accomplished. Also, there is one more important advantage of this drainage cleaning system is that the health of the workers working in drainage scavenging can be improved and maintained since they have to no longer be in drainage for its scavenging process. One more very useful and important advantage of our system is that this system can replace the manual work done in sewage scavenging by a semi-automatic scavenging system and the worker can access this system very easily and efficiently.

## **1.2 Background Study**

Automatic Drainage Water cleaning and Control System Using auto mechanism proposed to overcome the real time problems. With the continued expansion of industries, the problem of sewage water must be urgently resolved due to the increasing sewage problems from industries of the surrounding environment. The waste and gases produced from the industries are very harmful to human beings and to the environment. the proposed system is to cleaning and control the drainage level using auto mechanism technique. auto mechanism is the major controlling unit and the drainage level is monitor by municipal. In this system we used motor, chain, driver, bucket, frame. Before examine the function of a drive, we must understand the basic operation of the motor. It is used to convert the electrical energy, supplied by the controller, to mechanical energy to move the load. There are really two types of motors, AC and DC. The basic principles are alike for both. Magnetism is the basis for all electric motor operation. It produces the force required to run the motor.

## **1.3 Problem Statement**

In today's era automation plays a very important role in all industrial applications for the proper disposal of sewage from industries and household is still a challenging task. Drain pipes are used for the adequate disposal of waste and unfortunately sometimes there may be a threat to human life during the cleaning of blockage in the drain pipes or it can cause serious health issues because of the pertaining problems like malaria, dengue, etc.

In order to overcome this problem as well as to save human life we implement a design “Automatic Drainage Cleaning System”. We designed our project in order to use it in an efficient way to control the disposal of waste along with regular filtration of drains, removal of solid waste in order to avoid blockage in drains to promote continuous flow of drainage water which ultimately reduces the threat to human life.

## 1.4 Objective

We have some specific objectives for this project and they are pointed below:

- To design & construction of **Solar Based Automatic Drain Cleaner System**.
- To implementation of solar based Drain Cleaner system.
- To take output for future modification in our work.

## 1.5 Structure of the Project

This Project is organized as follows:

Chapter 1 Introduction: The first chapter contains the statement of the introduction, our background study for the project, problem statement, objectives of the study and the project outline.

Chapter 2 Literature Review: The chapter two contains our introduction, literature review part.

Chapter 3 Hardware and Software Analysis: Chapter three describes the theoretical model. Here we mainly discuss about proposed system Hardware and software development of our project etc.

Chapter 3 Methodology: Chapter three describes the theoretical model. Here we mainly discuss about proposed system architecture in details with having block diagram, circuit diagram, structural diagram, project working principle, complete project image etc.

Chapter 4 Result and Discussion: Chapter four deals with the result and discussion and discuss about our project advantages and application.

Chapter 5 Conclusion: Chapter five all about our project conclusion and future scope.

## CHAPTER 2

### LITERATURE REVIEW

#### **2.1 Introduction**

In this section topics related to Automatic Drain Cleaner System are included. These provide a sampling of problems appropriate for application of Automatic Drain Cleaner System. The references are summarized below.

#### **2.2 Literature Review**

Ganesh U L, et.al. [1] showed the usage of mechanical drainage cleaner to replace the manual work required for drainage cleaning system. Drainage pipes are very dirty. Sometimes it is harmful for human life while it is need for cleaning drainage system. To overcome this problem, they implemented a mechanical semi-automatic drainage water cleaner and so the water flow is efficient because of regular filtration of wastages with the help of that project. Different kinds of environment hazards reduced with the help of Drainage system machine.

Elan govan K., et.al. [2] reviewed about drainage cleaning to replace manual work to automated system because manually cleaning system it is harmful for human life and cleaning time, is more so to overcome this problem they implemented a design “Automatic drainage water pump monitoring and control system using PLC and SCADA”. PLC and SCADA were designed. In this project to use efficient way to control the disposal of wastage regularly, treatment of disposal in different way toxic and non-toxic gases. PLC controller from Siemens was used in the treatment system of drainage wastewater control by the stepper motor, compressor, gas exhauster, pressure valve and the liquid level, flow and other analog variables to achieve automatic control of sewage waste water treatment.

Dr.K.KUMARESAN [3] explained manual work converted to automated system. Drainage pipe using for disposal and it may be loss for human life while cleaning the blockage in the drainage pipes. To overcome this problem they implemented “Automatic Sewage Cleaning System”. They designed their project different way clearance of gaseous substance are treated separately so the flow of water efficiently. This project

may be developed with the full utilization of men, machines, and materials and money. They made their project economical and efficient with the available resources. They used automation technology concerned with his application of mechanical, electronics, computer based systems to operate and control production.

Sathiyakala, et.al. [4] explained E bucket (electronic bucket) use for drainage cleaning system because E-bucket lifted a sewage and used evaporation treatment for this sewage wet sewage was converted into dry matters, with the of ARM board (ARDUINO) this process was performed. After this process they were add this waste a government bank without any kind of affection of the bacteria.

S D Rahul Bharadwaj, et.al. [5] proposed with the automatic cleaning of waste water in order to prevent global warming and melting of glaciers. The results emphasize the need of waste water treatment plants, through which the water is treated before suspending in rivers. Firstly power is generated and that power is used for waste water cleaning process.

NitinSall, et.al. [6] explained flow of used water from homes, business industries, commercial activities is called waste water. 200 and 500 liters wastage water are generated each person every day. So using waste water technology that removes, rather than destroys, a pollutant in a drainage system.

Mr. Nikhil S. Pisal1, et.al. [7] proposed safe load for the chain and the ability of the same to withstand the use of Finite Element Modeling would be the core objective of the work. An existing chain link was used for benchmarking the research work. Finite Element Analysis tools like Hyper Mesh and ANSYS were suitable to find the performance of the link under tensile loads. The design for the chain would be subjected to F.E Analysis to find the effect of loads (tension) on the link. The proposed method utilizes software in the FEA domain for analyzing the effects of the variation in the values of the design parameters influencing the performance criterion. The FEM method is used to analyze the stress state of an elastic body with a given geometry, such as chain link.

NDUBUISI C. Daniels, et.al. [8] showed the Drainage system cleaner machine used to remove garbage and sewage automatically which helped to protect the environment from different kinds of environmental hazards. The drainage system cleaner has three major parts which are the Propeller, the Cleaner and the Pan all makes up for its effective functioning.

Shao-Wu-Zhang, et.al. [9] introduced three drainage devices about the ceramic filter dewatering system, improved the design according to the short coming of drainage device and working mechanism of automatic drainage device. This device have stable performance, low cost and low failure rate. They compared the working processes of three drainage devices, and analyzed its future development. Their aim was the shortcomings of the three types of drainage devices and their application situations, the automatic drainage device was improved.

Prof S.D.Anap, et.al. [10], showed blockage is the major cause of the pollution and flooding in the metro cities. They have designed the drainage blockage detection system to avoid such problems. The system provides monitoring of drainage condition and to inform authorities of these condition. This design preset an implementation wireless sensor network in the monitoring of drainage system using GSM system. To detecting blockage and monitoring water level condition we use level sensor. They explained about the design of the cost effective, easy method to control the water level of the tank wirelessly and automatically. They used level and IR sensor to monitor and control drainage blockage. They also used solenoid valve for bypass purpose.

James C.Y. Guo, et.al. [11] showed roadway sanding is a common practice in cold regions because sand increases the roadway friction when mixing with snow. In this study, a snow storage element is introduced to the renascence project of a mountainous highway which is running through an environmental sensitive forest area in Colorado. Recovery of winter sanding material from the highway was designed to be a joint effort of surface runoff and sweeping machines. As a tradeoff exist between sand recovery and size of snow storage area. This study also presented a maximization methodology by which the size of snow storage area can be determined by the diminishing return of sand recovery.

James C. Conwell, G. E. Jhonson [12] proposed the design and construction of a new test machine configuration that offers same advantages over the traditional one. The new machine and attendant instrumentation provide more realistic chain loading and allow link tension and roller sprocket impact monitoring during normal operation. The incorporation of idle sprocket allows independent adjustment of test on length and preload.

Prabhushankar, et.al. [13] showed dewatering of drainage is generally done using centrifugal pump, but using centrifugal pump is not much effective in complete removal of the suspended and heavy solids and also it consumes lot of electric power for its operation. The main aim of the proposed work was to remove drainage water by the pneumatic operated spring return reciprocating pump. It reduced the man power required for the drainage cleaning activity. Instead of slider crank mechanism the pneumatic and spring system with reciprocating cylinder was used which discharged the large sized drainage particles easily and there was no need of external power supply.

Gregor Burger, et.al. [14] described the concept and software design of an innovative general purpose platform for network based model development and look at some of crucial computational design issues. They developed the improvement in the design of very fast, easy to use, easy to integrate and extensible general purpose simulator platform. It was running up to 40 times faster than its MATLAB based predecessor and allowing it to be flexibly applied. They included features such as the hot-start mechanism and the extension interfaces have proven to be extremely useful when linking city drain 3 as a sub-model into larger software project.

MsT.Deepiga, et.al. [15] defined the water monitoring systems such as Tank water pollution monitoring and water pipeline leakage sensing monitoring. They avoided huge amount of water wasted by uncontrolled use of large apartments. They used the PID based water level monitoring to indicate the level of water in the tank.

## **2.3 Summary**

We try to do this project by reading the above literature, and we have been able to make our project successful by reducing the mistakes of last year's project.



CHAPTER 3  
HARDWARE AND SOFTWARE ANALYSIS

### 3.1 DC Gear Motor

Description:

A DC motor is any motor within a class of electrical machines whereby direct current electrical power is converted into mechanical power. A 12v DC motor is small and inexpensive, yet powerful enough to be used for many applications.

Specification:

- Voltage: 12V DC
- Gear ratio: 1/31
- No-load speed: 200 RPM
- Rated Speed: 140 RPM
- Rated torque: 10 kg.cm
- Rated current: 2.5 Amp
- Length of Motor (including spindle): 106 mm/4.17"
- Diameter: 37 mm/1.45"
- Shaft length: 21 mm/0.82"
- Shaft diameter: 6 mm/0.24"



Figure 3.1: DC Gear Motor

### 3.2 Solar Panel

A solar panel is a set of solar photovoltaic modules that are electrically connected and mounted on a support structure. A photovoltaic module is a packaged, connected assembly of solar cells. The solar panel can be used as a component of large photovoltaic systems for power generation and supply in commercial and residential applications. Each module is rated by DC output power under Standard Test Conditions (STC) and typically ranges from 100 to 320 watts. The efficiency of the module determines the area of the given module with the same rated output - an 8% efficient 230 watt module will be twice the area of a 16% efficient 230 watt module. A single solar module can produce only a limited amount of energy; Most organizations have more than one module. A photovoltaic system usually consists of an array of panels or solar modules, an inverter and sometimes a battery and / or solar tracker and interconnection wires.



Figure 3.2: Solar Panel

Solar cell modules only generate electricity when the sun is shining. They do not store energy, so to ensure the flow of electricity when the sun is not burning, some of the energy produced needs to be stored. The most obvious solution is to use batteries, which chemically store electrical energy. Batteries are connected in series with a group of electro chemical cells (devices that convert chemical energy into electrical energy). The battery cells have two electrodes immersed in the electrolyte solution which creates an electric current when a circuit is formed between them. The current is the result of opposite chemical reactions between the electrode and the electrolyte in the cell. Rechargeable batteries are called

secondary or rechargeable batteries. As the battery is charged, electrical energy is stored in the cells as chemical energy. During discharge, the stored chemical energy is removed from the battery and converted into electrical energy. Lead-acid batteries are the most common type of battery in East Africa.

A single solar module can produce only a limited amount of power; most installations contain multiple modules. A photovoltaic system typically includes a panel or an array of solar modules, an inverter, and sometimes a battery and/or solar tracker and interconnection wiring. Solar cell modules produce electricity only when the sun is shining. They do not store energy, therefore to ensure flow of electricity when the sun is not shining, it is necessary to store some of the energy produced.

The most obvious solution is to use batteries, which chemically store electric energy. Batteries are groups of electro-chemical cells (devices that convert chemical energy to electrical energy) connected in series. Battery cells are composed of two electrodes immersed in electrolyte solution which produce an electric current when a circuit is formed between them. The current is caused by reversible chemical reactions between the electrodes and the electrolyte within the cell. Batteries that are re-chargeable are called secondary or accumulator batteries. As the battery is being charged, electric energy is stored as chemical energy in the cells. These panels are designed with solar cells composed of semiconductor materials. The main function of Solar panels is to convert solar energy into DC electrical energy generally of 12V, which is further used for the rest of the circuit. The number of cells required and their size depends on the rating of the load. The collection of solar cells can produce maximum electricity. But, the solar panel must place exactly at right angles to the sun rays.

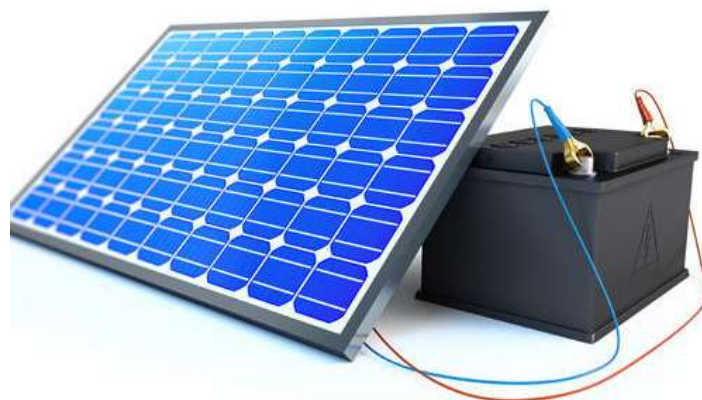

Figure 3.3: Picture of solar sell system.

### 3.3 Solar Charger Controller

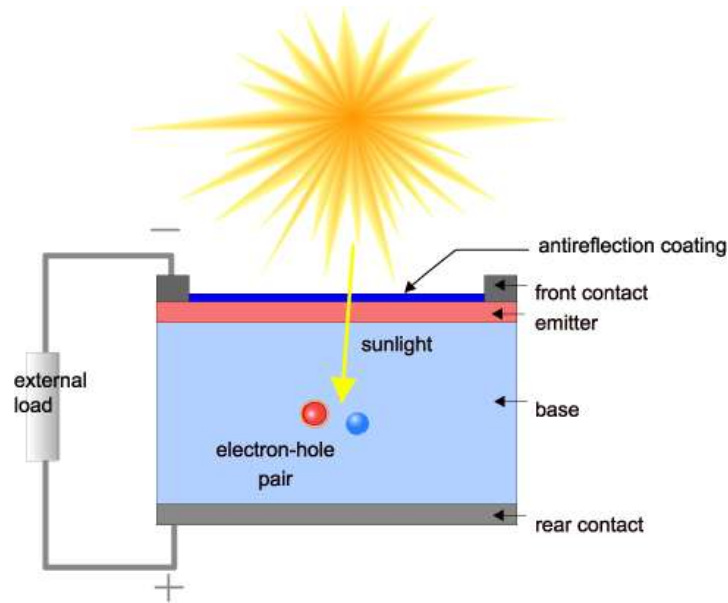

Figure 3.4: Solar Panel Schema Diagram

Here is a solar charger circuit that uses solar energy to charge lead acid or non-CD batteries. The circuit produces solar energy to charge a 6.5 4.5 rechargeable battery of 6 volts for various applications. The charger has voltage and current control and over voltage cut-off facility.

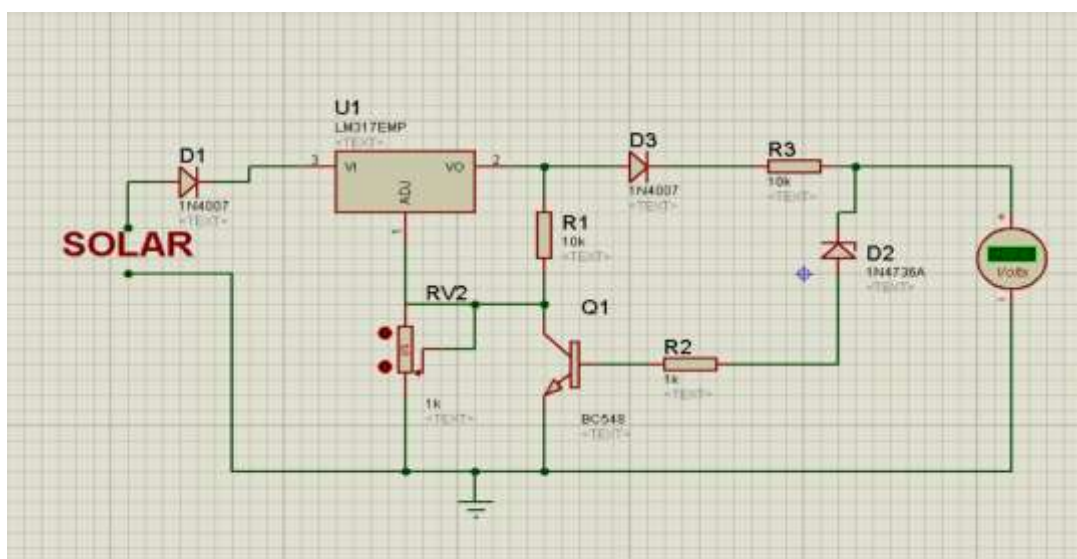

Figure 3.7: Solar Charger Controller Circuit

The circuit uses a 12volt solar panel and a variable voltage regulator IC LM317. A 12volt DC is available from the panel to charge the battery. Output voltage and current can be controlled by adjusting its adjusting pin when the current is charged via D1 in voltage regulator IC LM317. Adjustments are placed between the pin and ground to supply an output voltage of 9 volts to the VRT battery.

The resistor R3 limits the charging current and the diode D2 prevents the discharge of current from the battery. Transistor T1 and Zener diode ZD act as cutoff switches when the battery is full. Usually the T1 stays off and the battery current is charged. When the terminal voltage of the battery rises above 6.8 volts, the base current is supplied to the Zener T1. It then turns on the output grounding of the LM317 to stop charging.

### **3.4 12v Battery**

A twelve-volt battery consists of six single cells that produce a fully charged output voltage of 12.6 volts. Contains elements (separators).

### **Quick Details**

- Brand Name: DOUBLE TECH (rechargeable 12v dc battery pack)
- Model Number: DBG12-200(12V 200AH)
- Nominal Capacity: 200AH
- Place of Origin: Fujian, China
- Weight: 57kgs
- Certification: ISO9001,CE,MSDS
- rechargeable 12v dc battery pack: 1PCS/CTN(according to the actual situation)
- Production Capacity: rechargeable 12v dc battery pack:50000PCS/Month
- Lifetime: 8-12years
- OEM/ODM: 8 years experience
- Total Workers: 300
- QC Stuffs: 12

- Technical Engineers: 5
- Battery Production Lines: 5
- Factory space: 6000m<sup>2</sup>



Fig 3.8 : 12V Battery

### 3.5 The Smoothing Capacitor

When there is a potential difference across the conductors (e.g., when a capacitor is attached across a battery), an electric field develops across the dielectric, causing positive charge (+Q) to collect on one plate and negative charge (-Q) to collect on the other plate. If a battery has been attached to a capacitor for a sufficient amount of time, no current can flow through the capacitor. However, if an accelerating or alternating voltage is applied across the leads of the capacitor, a displacement current can flow.



Figure 3.9: Capacitor

An ideal capacitor is characterized by a single constant value for its capacitance. Capacitance is expressed as the ratio of the electric charge ( $Q$ ) on each conductor to the potential Difference ( $V$ ). The SI unit of capacitance is the farad (F), which is equal to one coulomb per volt ( $1\text{ C/V}$ ). Typical capacitance values range from about  $1\text{ pF}$  ( $10^{-12}\text{ F}$ ) to about  $1\text{ mF}$  ( $10^{-3}\text{ F}$ ). The capacitance is greater when there is a narrower separation between conductors and when the conductors have a larger surface area.

In practice, the dielectric between the plates passes a small amount of leakage current and also has an electric field strength limit, known as the breakdown voltage. The conductors and leads introduce an undesired inductance and resistance. Capacitors are widely used in electronic circuits for blocking direct current while allowing alternating current to pass. In analog filter networks, they smooth the output of power supplies. In resonant circuits they tune radios to particular frequencies. In electric power transmission systems, they stabilize voltage and power flow.

The full-wave bridge rectifier however, gives us a greater mean DC value ( $0.637\text{ V}_{\text{max}}$ ) with less superimposed ripple while the output waveform is twice that of the frequency of the input supply frequency. We can improve the average DC output of the rectifier while at the same time reducing the AC variation of the rectified output by using smoothing capacitors to filter the output waveform. Smoothing or reservoir capacitors connected in parallel with the load across the output of the full wave bridge rectifier circuit increases the average DC output level even higher as the capacitor acts like a storage device as shown below. Too low a capacitance value and the capacitor has little effect on the output waveform. But if the smoothing capacitor is sufficiently large enough (parallel capacitors can be used) and the load current is not too large, the output voltage will be almost as smooth as pure DC.

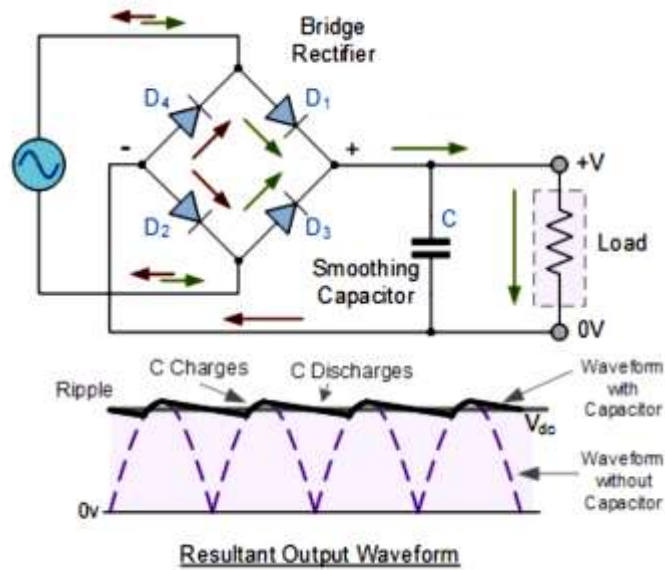

Figure 3.10: The Smoothing Capacitor with Full Bridge Rectifier

### 3.6 Resistor

A resistor is a passive two-terminal electrical component that implements electrical resistance as a circuit element. Resistors act to reduce current flow, and, at the sometime, act to lower voltage levels within circuits. Resistors may have fixed resistances or variable resistances, such as those founding thermostats, visitors, trimmers, photo resistors, hamsters and potentiometer. The current through a resistor is in direct proportion to the voltage across the resistor's terminals. This relationship is represented by Ohm's law.



Figure 3.11: Resistor



Theory of operation:

The behavior of an ideal resistor is dictated by the relationship specified by Ohm 'slaw:

$$V = I.R$$

Ohm's law states that the voltage (V) across a resistor is proportional to the current (I), where the constant of proportionality is the resistance (R).

Equivalently, Ohm's law can be stated:

$$I = V/R$$

This formulation states that the current (I) is proportional to the voltage (V) and inversely proportional to the resistance (R). This is directly used in practical computations. For example, if a 300ohm resistor is attached across the terminals of a 12 volt battery, then a current of  $12 / 300 = 0.04$  amperes flows through that resistor.

### **3.7 Easy EDA Software**

Easy EDA is a web-based EDA tool suite that enables hardware engineers to design, simulate, share - publicly and privately - and discuss schematics, simulations and printed circuit boards. Other features include the creation of a bill of materials, Gerber files and pick and place files and documentary outputs in PDF, PNG and SVG formats. EasyEDA allows the creation and editing of schematic diagrams, SPICE simulation of mixed analogue and digital circuits and the creation and editing of printed circuit board layouts and, optionally, the manufacture of printed circuit boards.

Subscription-free membership is offered for public plus a limited number of private projects. The number of private projects can be increased by contributing high quality public projects, schematic symbols, and PCB footprints and/or by paying a monthly subscription. Registered users can download Gerber files from the tool free of charge; but for a fee, Easy EDA offers a PCB fabrication service. This service is also able to accept Gerber file inputs from third party tools.

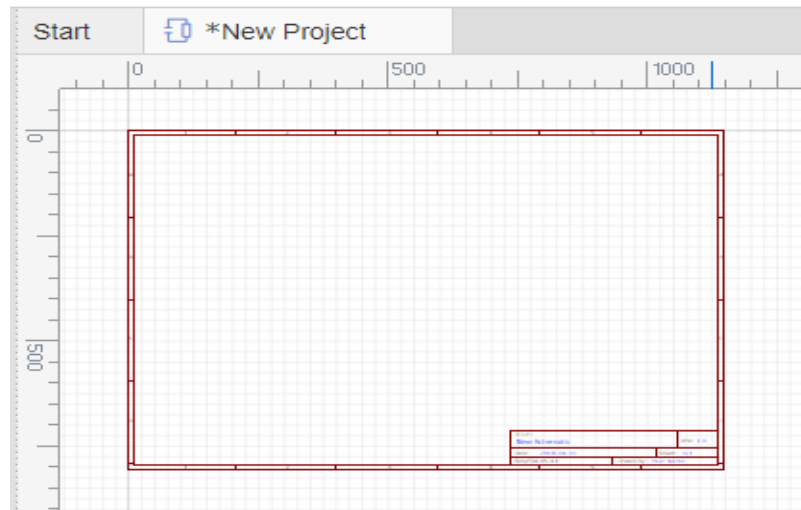

Figure 3.12: Easy EDA Software Interface

## CHAPTER 4 METHODOLOGY

### 4.1 Our methodologies for the project

Our methodologies for the project:

- Creating an idea for **A Solar Based Automatic Drain Cleaner System.**
- And designing a block diagram & circuit diagram to know which components need to construct it.
- Collecting the all components and programming for the micro controller to controlled the system.
- Setting all components in a PCB board & soldering. Then assembling the all block in a board and finally run the system & checking.

### 4.2 Structural Design

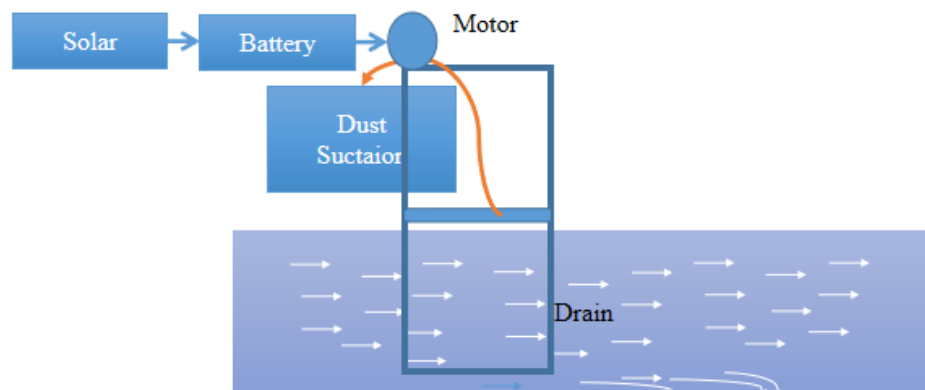

Figure 4.1: Our Project Structural View

### 4.3 Block Diagram

The way of whole project works is that we use DC 12V from the supply voltage and control the all module. Here we use Solar, Battery, switch and a DC Motor. Here we also use various instrument which is visible in this block diagram.

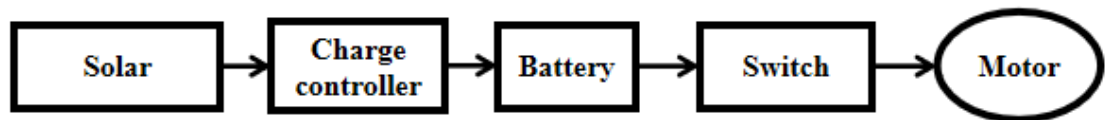

Figure 4.2: Block Diagram of Our System

### 4.4 Schematic Diagram

The schematic diagram here is representing the electrical circuit and the components of the project. Here we have used standardized symbols and lines.

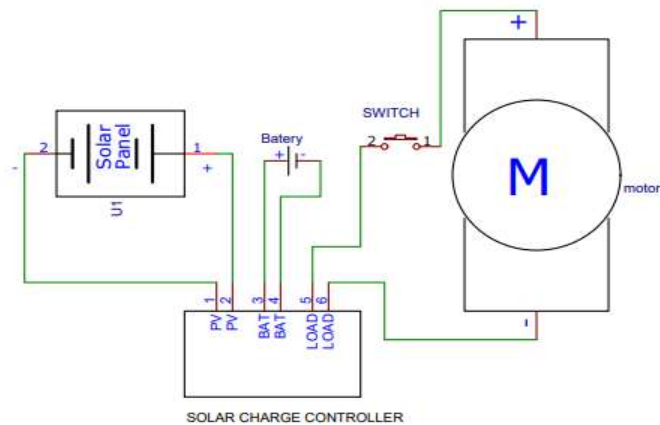

Figure 4.2: Schematic Diagram of the Project

## 4.5 Working Principle

The Device is place across drain so that only water flow through lower grids. Waste like bottle, etc. Floating in drain are lifted by teeth which is connected to chain. This chain is attached by gears driven by motor. The energy provided to 12V DC to motor connected to it. When motor runs the chain starts to circulate making teeth to lift up. The waste materials are lifted by teeth and are stored in waste storage tank. When we need to of this machine then switch off. In this way the whole system is controlled.

## 4.6 Our Final System View



Figure 4.3: Our Final System Overview

## CHAPTER 5 RESULT AND DISCUSSION

### 5.1 Discussion

While working on our project, we did face some difficulties as it is a very complex system but the end results, we came up with were quite satisfactory. We have put the whole system through several tasks to validate our work and also have taken necessary notes for future improvements. Some future recommendations that we have involves improvement in system design and wiring, adding features for more efficient.

### 5.2 Result

Now, it's time to talk about the results. We have written our commands using the Arduino IDE and the following things can happen:

- At first we start the project then solar energy storage of battery.
- After power this project then it will be able to operate.
- Then a saw teeth will rotate with a chains.
- Then a motor will such the dust of the water and saw teeth will take it up.
- And store in a tank.

### 5.3 Advantage

There are many advantages of our project because of its accuracy. Some of the advantages are pointed out below:

- Automatic Cleaning System.
- Automatic Dust Collecting.
- Production cost is very low.
- No need of purchase special machine.
- Its operated and maintenance is simple.
- It is compact and portable.
- It can be efficiently used.

## **5.4 Application**

Some of the application areas of the project have been pointed out below:

- It is used almost in all types of Drainage (Large, Small & medium).
- This machine is mainly used in cleaning system.
- Project to use this in efficient way to control the disposal of wastages and with regular filtration of wastages.

## CHAPTER 6 CONCLUSION

### **6.1 Conclusion**

In the cleaning system of drainage control by the, motor, roller chain and sprocket, lifter and the collecting bin to achieve automatic control system. Automation is a technology concerned with his application of mechanical, electronic and computer based systems to operate and control production. This system is used to operate automatic drain cleaning system. We have followed thoroughly the study of time motion and made our project economical and efficient with the available resources. This system was designed, fabricated successfully and also tested. It works satisfactorily. We hope that this will be done among the most versatile and interchangeable one even in future. Thus we can able to obtain Automatic drain Cleaning system.

### **6.2 Future Scope**

We are thinking about adding many features to our project in the future to get more desirable outcomes. Some of the steps that we are thinking about taking are given below:

- In the future it can be improved by using more sensors.
- In the future, controlling the Internet can be done to improve it



## REFERENCE

- [1] Ganesh U L, et.al. "Semi-Automatic Drain For Sewage Water Treatment Of Floating Materials", International Journal of Research in Engineering and Technology, Vol No- 05, Jul-2016.
- [2] Balachandra, et.al."Automatic Drainage Water Pump Monitoring and Control System Using PLC and SCADA" International Journal of Innovative Research in Technology, Vol No- 1, 2014.
- [3] Dr .K.Kumaresan et.al., "Automatic Sewage Cleaning Equipment", International Conference on Explorations and Innovations in Engineering and Technology , 2016.
- [4] R.Sathiyakala et.al., "Smart Sewage Cleaning System" International Journal of Innovative Research in Computer and Communication Engineering, Vol No- 4, February 2016.
- [5] S D Rahul Bharadwaj, Shraddha R Jogdhankar, "Automatic Wastewater treatment process to reduce global warming" International Journal of Environmental Science: Development and Monitoring, Vol No- 2 (2013)
- [6] Nitin Sall, et.al., "Drain Waste Water Cleaner", Global Journal of Researches in Engineering: J General Engineering Vol No- 16, 2016.
- [7] Nikhil S. Pisal, et.al., "Structural Analysis Of Motorcycle Chain By Using C.A.E. Software", International Journal Of Advance Research In Science and Engineering, Vol No-4, Special Issue (02), February 2015.
- [8] NDUBUISI C. Daniels, "Drainage System Cleaner A Solution to Environmental Hazards", International Referred Journal of Engineering and Science, Vol No- 3, March 2014.
- [9] Shao-Wu-Zhang, "Drainage Device's Research and Development in the Ceramic Filters", Journal of Chemical and Pharmaceutical Research, 2013.

- [10] S.D.Anap,” Wireless Based Water Level Monitoring and Control System”, International Advanced Research Journal in Science, Engineering and Technology, Vol No- 3, April 2016.
- [11] James C.Y. Guo, “Winter Sand Recollection By Highway Drainage”, ASCE J. of Drainage and Irrigation Engineering, Vol 125, No 6, November1999.
- [12] James C. Conwell, G.E. Jhonson, “Design, Construction and Instrumentation of a Machine to Measured Tension and Impact Forces in Roller Chain Drives”, December 1989.
- [13] N.Prabhushankaret.al.”Design and Fabrication of Drainage Cleaning Machine with Spring Return Pneumatic System”, International Journal For Scientific Research and Development, Vol No-4, 2016.
- [14] Gregor Burger, et.al, “Designing and Implementing a Multi-Core Capable Integrated Urban Drainage Modelling Toolkit: Lessons from CityDrain3”, Advances in Engineering Software 100, 2016.
- [15] MsT.Deepiga, et.al., “Smart Water Monitoring System Using Wireless Sensor Network at Home/Office”, International Research Journal of Engineering and Technology, Vol- 02, July-2015.