



UGC & Govt. Approved  
**Sonargaon University (SU)**  
সোনারগাঁও ইউনিভার্সিটি (এসইউ)

## Design and Development of Automatic Drain Cleaner System

A Thesis

By

Naim Sheikh	ID: BME1903019124
Md. Shakibul Hassan	ID: BME1903019132
Md. Asaduzzaman	ID: BME 1903019167
Md. Sohel Gazi	ID: BME1903019297
Md. Motaleb Hossen	ID: BME1701011043
Yousuf Shakh Mahmud	ID: BME1802015186

Supervisor

Md. Mahedy Hasan

Assistant Professor

Department of Mechanical Engineering

Sonargaon University (SU)

Dhaka-1215, Bangladesh

28 May, 2023

# Design and Development of Automatic Drain Cleaner System

Submitted by

Naim Sheikh	ID: BME1903019124
Md. Shakibul Hassan	ID: BME1903019132
Md. Asaduzzaman	ID: BME 1903019167
Md. Sohel Gazi	ID: BME1903019297
Md. Motaleb Hossen	ID: BME1701011043
Yousuf Shakh Mahmud	ID: BME1802015186



Md. Mahedy Hasan  
Assistant Professor

SUBMITTED TO THE:

Department of Mechanical Engineering

SONARGAON UNIVERSITY (SU)

In partial fulfillment of the requirement for award of the degree  
Of  
Bachelor of Science in Mechanical Engineering

May, 2023

## LETTER OF TRANSMITTAL

May, 2023

To

Md. Mahedy Hasan

Assistant Professor

Department of Mechanical Engineering.

Sonargaon University

Subject: Submission of Project Report.

Dear Sir,

We are pleased to submit the project report on “**Design and Development of Automatic Drain Cleaner System**”. It was a great pleasure to work on such an important topic. This project has been done as per instruction of your supervision and according to the requirements of the Sonargaon University.

We expect that the project will be accepted by the concerned authority we will remain happy to further explanation that you may feel necessary in this regard.

Thank You

Sincerely yours,

Naim Sheikh

ID: BME1903019124

Md. Motaleb Hossen

ID: BME1701011043

Md. Shakibul Hassan

ID: BME1903019132

Yousuf Shakh Mahmud

ID: BME1802015186

Md. Sohel Gazi

ID: BME1903019297

Md. Asaduzzaman

ID: BME 1903019167

## DECLARATION

We do hereby solemnly declare that, the work presented here in this project report has been carried out by us and has not been previously submitted to any University/ Organization for award of any degree or certificate

We hereby ensure that the works that has been prevented here does not breach any existing copyright.

We further undertake to indemnify the university against any loss or damage arising from breach of the foregoing obligation.

Naim Sheikh  
ID: BME1903019124

Md. Motaleb Hossen  
ID: BME1701011043

Md. Shakibul Hassan  
ID: BME1903019132

Yousuf Shakh Mahmud  
ID: BME1802015186

Md. Sohel Gazi  
ID: BME1903019297

Md. Asaduzzaman  
ID: BME 1903019167

## ACKNOWLEDGEMENT

First, we started in the name of almighty Allah. This thesis is accomplished under the supervision of Md. Mahedy Hasan, Assistant Professor, Department of Mechanical, Sonargaon University. It is a great pleasure to acknowledge our profound gratitude and respect to our supervisor for this consistent guidance, encouragement, helpful suggestion, constructive criticism and endless patience through the progress of this work. The successful completion of this thesis would not have been possible without his persistent motivation and continuous guidance.

The authors are also grateful to Md. Mostofa Hossain, Head of the Department of Mechanical Engineering and all respect teachers of the Mechanical Engineering Department for their co-operation and significant help for completing the thesis work successfully.

## ABSTARCT

In this project the proposed concept is to replace the manual work in drainage cleaning by automated system controlled by micro-controller. Now-a-days even though automation plays a vital role in all industrial applications in the proper disposal of sewage from industries and commercials are still a challenging task. Drainage pipes are using for the disposal and unfortunately sometimes there may be loss of human life while cleaning the blockages in the drainage pipes. To overcome this problem and to save human life we implement a design and construction of Design and Development of Automatic Drain Cleaner System. We designed our project to use this in efficient way to control the disposal of wastage's and with regular filtration of wastage's, clearance of gaseous substance are treated separately and monitor the disposal in frequent manner.

## TABLE OF CONTENTS

Letter of Transmittal	ii
Declaration	iii
Acknowledgement	iv
Abstract	v
Table of Contents	vi
Table of Figure	viii
CHAPTER-1	INTRODUCTION
1.1 Introduction	01
1.2 Background Study	02
1.3 Problem Statement	02
1.4 Objective	03
1.5 Structure of the Projects	03
CHAPTER 2	LITERATURE REVIEW
2.1 Introduction	05
2.2 Literature Review	05
2.3 Summary	08
CHAPTER-3	HARDWARE AND SOFTWARE ANALYSIS
3.1 DC Gear Motor	09
3.2 Transformer	10
3.3 Full Wave Bridge Rectifier	11
3.4 Smoothing Capacitor	13
3.5 Resistor	15
3.6 EasyEDA Software	16
CHAPTER-4	METHODOLOGY
4.1 Methodology	18
4.2 Structural Design	18
4.3 Block Diagram	19

4.4 Schematic Diagram	19
4.5 Working Principle	19
4.6 Our Final Project View	20
<b>CHAPTER-5</b>	<b>RESULT AND DISCUSSION</b>
5.1 Discussion	21
5.2 Result	21
5.3 Advantage	21
5.4 Application	22
<b>CHAPTER-6</b>	<b>CONCLUSION</b>
6.1 Conclusion	23
6.2 Future Scope	23
Reference	24



## LIST OF FIGURES

FIGURE NO	FIGURE NAME	PAGE
3.1	DC Gear Motor	09
3.2	Transformer	10
3.3	The Diode Bridge Rectifier	12
3.4	The Positive Half Cycle	12
3.5	The Negative Half Cycle	13
3.6	Capacitor	14
3.7	The Smoothing Capacitor with Full Bridge Rectifier	15
3.8	Resistor	15
3.9	EasyEDA Software Interface	17
4.1	Our Project Structural View	18
4.2	Block Diagram	19
4.3	Schematic Diagram	19
4.4	Our Final System Overview	20

# CHAPTER 1

## INTRODUCTION

### **1.1 Introduction**

The proper disposal of common wastes is still a challenge faced nowadays, even though automation plays a vital role in the industrial and commercial applications. Usually what we see in a country like India is that common wastes like plastic bottles, covers, sanitary pads, etc and others are left in the streets and in the open drains. These waste particles obviously cause blockage of the drainage system during monsoon season when there is a flow of water through the roads and drainage systems. Also, where the closed drainage system open near a river causes the pollution of river. This blockage of drainage system can cause accumulation of waste water in these drains.

Several water borne diseases such as cholera, worm disease, typhoid, malaria etc will occur due to the contamination of these stagnant water. This can cause many health issues and may even lead to deaths, other than the local common issues caused by the blockage of drainage. In India, there is no existing automated mechanism by which this blockage of drainage can be removed. Currently these blocked drains are cleared with the help of manual workers were the workers have to get into the drains and manually remove the wastes. In such situations the rate of diseases spread among these workers are high and this affects their life's and reduces their immunity.

Since the world is fast approaching towards the technology of digitalization and automation, humans want every task and operations to be performed quickly and easily. Now the time is for advanced techniques which can perform tasks efficiently and with minimum time. The human wants to apply minimum effort in order to accomplish its tasks. To achieve this there has to be automated techniques which can fulfill these objectives. Hence in this project we tried to add this automation technology with the knowledge of drainage systems in order to make the drainage cleaning system easy and efficient tool for the cleaning of the drainage systems and hence save the environment. For this we are using system by which drainage cleaner can do his work smartly using communication through application.

The problem of the sewage disposal coming from the industries is growing rapidly day by day and thus it needs to be resolved urgently since this problem is causing various environmental issues and is very harmful to the human life. This is a real time problem and it needs to be resolved and overall speaking this proposed concept is very much efficient in this work to be accomplished. Also, there is one more important advantage of this drainage cleaning system is that the health of the workers working in drainage scavenging can be improved and maintained since they have to no longer be in drainage for its scavenging process. One more very useful and important advantage of our system is that this system can replace the manual work done in sewage scavenging by a semi-automatic scavenging system and the worker can access this system very easily and efficiently.

## **1.2 Background Study**

Automatic Drainage Water cleaning and Control System Using auto mechanism proposed to overcome the real time problems. With the continued expansion of industries, the problem of sewage water must be urgently resolved due to the increasing sewage problems from industries of the surrounding environment. The waste and gases produced from the industries are very harmful to human beings and to the environment. the proposed system is to cleaning and control the drainage level using auto mechanism technique. auto mechanism is the major controlling unit and the drainage level is monitor by municipal . In this system we used motor, chain, driver, bucket, frame. Before examine the function of a drive, we must understand the basic operation of the motor. It is used to convert the electrical energy, supplied by the controller, to mechanical energy to move the load. There are really two types of motors, AC and DC. The basic principles are alike for both. Magnetism is the basis for all electric motor operation. It produces the force required to run the motor.

## **1.3 Problem Statement**

In today's era automation plays a very important role in all industrial applications for the proper disposal of sewage from industries and household is still a challenging task. Drain pipes are used for the adequate disposal of waste and unfortunately sometimes there may be a threat to human life during the cleaning of blockage in the drain pipes or it can cause serious health issues because of the pertaining problems like malaria, dengue, etc.

In order to overcome this problem as well as to save human life we implement a design “Automatic Drainage Cleaning System”. We designed our project in order to use it in an efficient way to control the disposal of waste along with regular filtration of drains, removal of solid waste in order to avoid blockage in drains to promote continuous flow of drainage water which ultimately reduces the threat to human life.

## **1.4 Objective**

We have some specific objectives for this project and they are pointed below:

- To design & construction of Automatic Drain Cleaner System.
- To implementation of motor based Drain Cleaner system.
- To take some output for future modification in our work.
- To study the system performance for future reference and improvement purposes.

## **1.5 Structure of the Project**

This Project is organized as follows:

**Chapter 1 Introduction:** The first chapter contains the statement of the introduction, our background study for the project, problem statement, objectives of the study and the project outline.

**Chapter 2 Literature Review:** The chapter two contains our introduction, literature review part.

**Chapter 3 Hardware and Software Analysis:** Chapter three describes the theoretical model. Here we mainly discuss about proposed system Hardware and software development of our project etc.

**Chapter 3 Methodology:** Chapter three describes the theoretical model. Here we mainly discuss about proposed system architecture in details with having block diagram, circuit diagram, structural diagram, project working principle, complete project image etc.

**Chapter 4 Result and Discussion:** Chapter four deals with the result and discussion and discuss about our project advantages and application.

**Chapter 5 Conclusion:** Chapter five all about our project conclusion and future scope.

## CHAPTER 2

### LITERATURE REVIEW

#### **2.1 Introduction**

In this section topics related to Design and Development of Automatic Drain Cleaner System are included. These provide a sampling of problems appropriate for application of Design and Development of Automatic Drain Cleaner System. The references are summarized below.

#### **2.2 Literature Review**

Ganesh U L, et.al. [1] showed the usage of mechanical drainage cleaner to replace the manual work required for drainage cleaning system. Drainage pipes are very dirty. Sometimes it is harmful for human life while it is need for cleaning drainage system. To overcome this problem, they implemented a mechanical semi-automatic drainage water cleaner and so the water flow is efficient because of regular filtration of wastages with the help of that project. Different kinds of environment hazards reduced with the help of Drainage system machine.

Elangovan K., et.al. [2] reviewed about drainage cleaning to replace manual work to automated system because manually cleaning system it is harmful for human life and cleaning time, is more so to overcome this problem they implemented a design “Automatic drainage water pump monitoring and control system using PLC and SCADA”. PLC and SCADA were designed. In this project to use efficient way to control the disposal of wastage regularly, treatment of disposal in different way toxic and non-toxic gases. PLC controller from Siemens was used in the treatment system of drainage wastewater control by the stepper motor, compressor, gas exhauster, pressure valve and the liquid level, flow and other analog variables to achieve automatic control of sewage waste water treatment.

Dr.K.KUMARESAN [3] explained manual work converted to automated system. Drainage pipe using for disposal and it may be loss for human life while cleaning the blockage in the drainage pipes. To overcome this problem they implemented “Automatic Sewage Cleaning System”. They designed their project different way clearance of gaseous substance are treated separately so the flow of water efficiently. This project may

be developed with the full utilization of men , machines, and materials and money. They made their project economical and efficient with the available resources. They used automation technology concerned with his application of mechanical, electronics, computer based systems to operate and control production.

Sathiyakala, et.al. [4] explained E bucket (electronic bucket) use for drainage cleaning system because E-bucket lifted a sewage and used evaporation treatment for this sewage wet sewage was converted into dry matters, with the of ARM board (ARDUINO) this process was performed. After this process they were add this waste a government bank without any kind of affection of the bacteria.

S D Rahul Bharadwaj, et.al. [5] proposed with the automatic cleaning of waste water in order to prevent global warming and melting of glaciers. The results emphasize the need of waste water treatment plants, through which the water is treated before suspending in rivers. Firstly power is generated and that power is used for waste water cleaning process.

Nitin Sall, et.al. [6] explained flow of used water from homes, business industries, commercial activities is called waste water. 200 and 500 liters wastage water are generated each person every day. So using waste water technology that removes, rather than destroys, a pollutant in a drainage system.

Mr. Nikhil S. Pisal1, et.al. [7] proposed safe load for the chain and the ability of the same to withstand the use of Finite Element Modeling would be the core objective of the work. An existing chain link was used for benchmarking the research work. Finite Element Analysis tools like Hyper Mesh and ANSYS were suitable to find the performance of the link under tensile loads. The design for the chain would be subjected to F.E Analysis to find the effect of loads (tension) on the link. The proposed method utilizes software in the FEA domain for analyzing the effects of the variation in the values of the design parameters influencing the performance criterion. The FEM method is used to analyze the stress state of an elastic body with a given geometry, such as chain link.

NDUBUISI C. Daniels, et.al. [8] showed the Drainage system cleaner machine used to remove garbage and sewage automatically which helped to protect the environment from different kinds of environmental hazards. The drainage system cleaner has three major parts which are the Propeller, the Cleaner and the Pan all makes up for its effective functioning.

Shao-Wu-Zhang, et.al. [9] introduced three drainage devices about the ceramic filter dewatering system, improved the design according to the short coming of drainage device and working mechanism of automatic drainage device. This device have stable performance, low cost and low failure rate. They compared the working processes of three drainage devices, and analyzed its future development. Their aim was the shortcomings of the three types of drainage devices and their application situations, the automatic drainage device was improved.

Prof S.D. Anap, et.al. [10], showed blockage is the major cause of the pollution and flooding in the metro cities. They have designed the drainage blockage detection system to avoid such problems. The system provides monitoring of drainage condition and to inform authorities of these condition. This design preset an implementation wireless sensor network in the monitoring of drainage system using GSM system. To detecting blockage and monitoring water level condition we use level sensor. They explained about the design of the cost effective, easy method to control the water level of the tank wirelessly and automatically. They used level and IR sensor to monitor and control drainage blockage. They also used solenoid valve for bypass purpose.

James C.Y. Guo, et.al. [11] showed roadway sanding is a common practice in cold regions because sand increases the roadway friction when mixing with snow. In this study, a snow storage element is introduced to the renascence project of a mountainous highway which is running through an environmental sensitive forest area in Colorado. Recovery of winter sanding material from the highway was designed to be a joint effort of surface runoff and sweeping machines. As a tradeoff exist between sand recovery and size of snow storage area. This study also presented a maximization methodology by which the size of snow storage area can be determined by the diminishing return of sand recovery.



James C. Conwell, G. E. Jhonson [12] proposed the design and construction of a new test machine configuration that offers same advantages over the traditional one. The new machine and attendant instrumentation provide more realistic chain loading and allow link tension and roller sprocket impact monitoring during normal operation. The incorporation of idle sprocket allows independent adjustment of test on length and preload.

Prabhushankar, et.al. [13] showed dewatering of drainage is generally done using centrifugal pump, but using centrifugal pump is not much effective in complete removal of the suspended and heavy solids and also it consumes lot of electric power for its operation. The main aim of the proposed work was to remove drainage water by the pneumatic operated spring return reciprocating pump. It reduced the man power required for the drainage cleaning activity. Instead of slider crank mechanism the pneumatic and spring system with reciprocating cylinder was used which discharged the large sized drainage particles easily and there was no need of external power supply.

Gregor Burger, et.al. [14] described the concept and software design of an innovative general purpose platform for network based model development and look at some of crucial computational design issues. They developed the improvement in the design of very fast, easy to use, easy to integrate and extensible general purpose simulator platform. It was running up to 40 times faster than its MATLAB based predecessor and allowing it to be flexibly applied. They included features such as the hot-start mechanism and the extension interfaces have proven to be extremely useful when linking city drain 3 as a sub-model into larger software project.

MsT.Deepiga, et.al. [15] defined the water monitoring systems such as Tank water pollution monitoring and water pipeline leakage sensing monitoring. They avoided huge amount of water wasted by uncontrolled use of large apartments. They used the PID based water level monitoring to indicate the level of water in the tank.

## **2.3 Summary**

We try to do this project by reading the above literature, and we have been able to make our project successful by reducing the mistakes of last year's project.

CHAPTER 3  
HARDWARE AND SOFTWARE ANALYSIS

### 3.1 DC Gear Motor

Description:

A DC motor is any motor within a class of electrical machines whereby direct current electrical power is converted into mechanical power. A 12v DC motor is small and inexpensive, yet powerful enough to be used for many applications.

Specification:

- Voltage: 12V DC
- Gear ratio: 1/31
- No-load speed: 200 RPM
- Rated Speed: 140 RPM
- Rated torque: 10 kg.cm
- Rated current: 2.5 Amp
- Length of Motor(including spindle): 106 mm/4.17"
- Diameter: 37 mm/1.45"
- Shaft length: 21 mm/0.82"
- Shaft diameter: 6 mm/0.24"



Figure 3.1: DC Gear Motor

### 3.2 Transformer

12-0-12 3Amp Center Tapped Step Down Transformer is a general-purpose chassis mounting mains transformer. Transformer has 230V primary winding and center tapped secondary winding. The transformer has flying colored insulated connecting leads (Approx. 100 mm long). The Transformer act as step down transformer reducing AC - 230V to AC - 12V. The Transformer gives outputs of 12V, 12V and 0V. The Transformer's construction is written below with details of Solid Core and Winding.

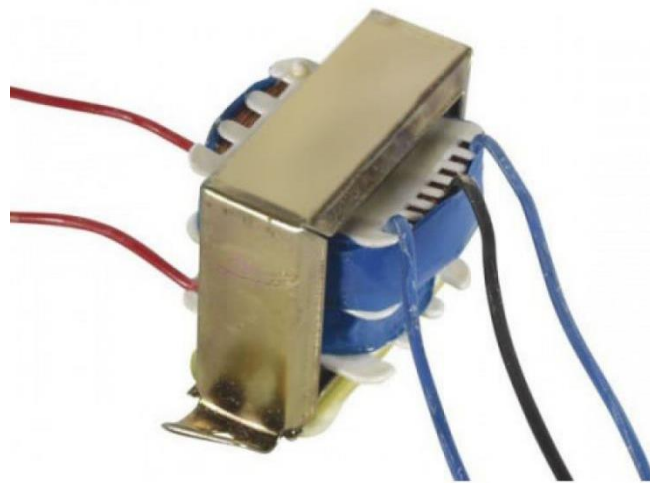

Figure 3.2: Transformer

The transformer is a static electrical device that transfers energy by inductive coupling between its winding circuits. A varying current in the primary winding creates a varying magnetic flux in the transformer's core and thus a varying magnetic flux through the secondary winding. This varying magnetic flux induces a varying electromotive force (E.M.F) or voltage in the secondary winding. The transformer has cores made of high permeability silicon steel. The steel has a permeability many times that of free space and the core thus serves to greatly reduce the magnetizing current and confine the flux to a path which closely couples the winding.

#### **Specifications of 12-0-12 3 Ampere Center Tapped Transformer: -**

- Input Voltage: 230V AC
- Output Voltage: 12V, 12V or 0V
- Output Current: 3 Amp

- Mounting: Vertical mount type
- Winding: Copper

**Features of 12-0-12 3 Ampere Center Tapped Transformer: -**

- Soft Iron Core.
- 3 Amp Current Drain.
- 100% Copper Winding

**Applications of 12-0-12 3 Ampere Center Tapped Transformer: -**

- DIY projects Requiring In-Application High current drain.
- On chassis AC/AC converter.
- Designing a battery Charger.

### **3.3 The Full Wave Bridge Rectifier**

Another type of circuit that produces the same output waveform as the full wave rectifier circuit above, is that of the **Full Wave Bridge Rectifier**. This type of single-phase rectifier uses four individual rectifying diodes connected in a closed loop “bridge” configuration to produce the desired output. The main advantage of this bridge circuit is that it does not require a special center tapped transformer, thereby reducing its size and cost. The single secondary winding is connected to one side of the diode bridge network and the load to the other side as shown below.

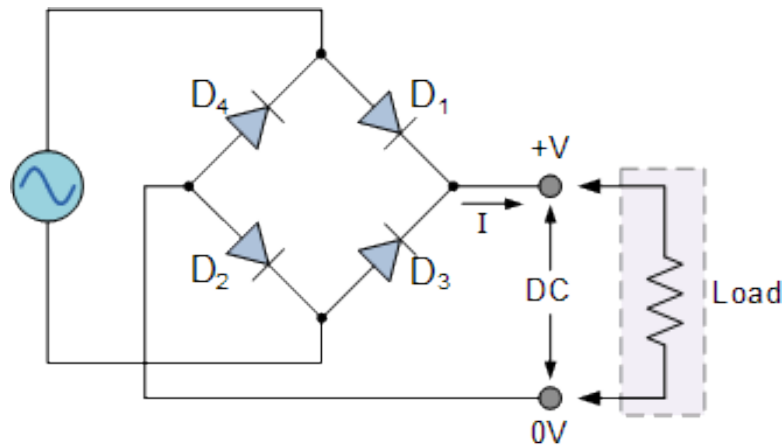

Figure 3.3: The Diode Bridge Rectifier

The four diodes labelled  $D_1$  to  $D_4$  are arranged in “series pairs” with only two diodes conducting current during each half cycle. During the positive half cycle of the supply, diodes  $D_1$  and  $D_2$  conduct in series while diodes  $D_3$  and  $D_4$  are reverse biased and the current flows through the load as shown below.

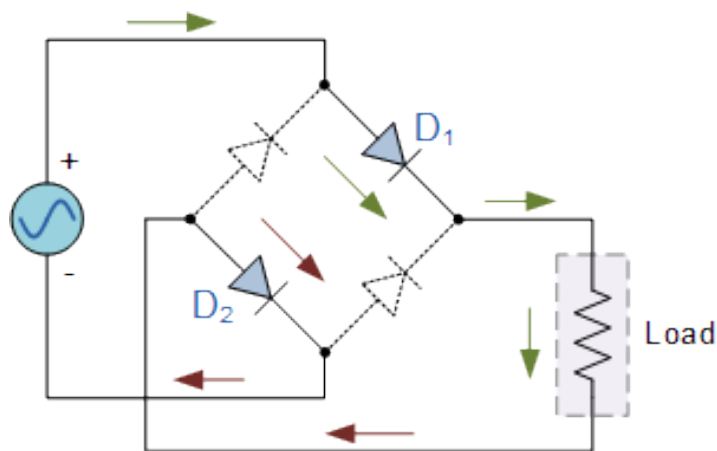

Figure 3.4: The Positive Half-cycle

During the negative half cycle of the supply, diodes  $D_3$  and  $D_4$  conduct in series, but diodes  $D_1$  and  $D_2$  switch “OFF” as they are now reverse biased. The current flowing through the load is the same direction as before. As the current flowing through the load is unidirectional, so the voltage developed across the load is also unidirectional the same as for the previous two diode full-wave rectifier, therefore the average DC voltage across the load is  $0.637V_{\max}$ .

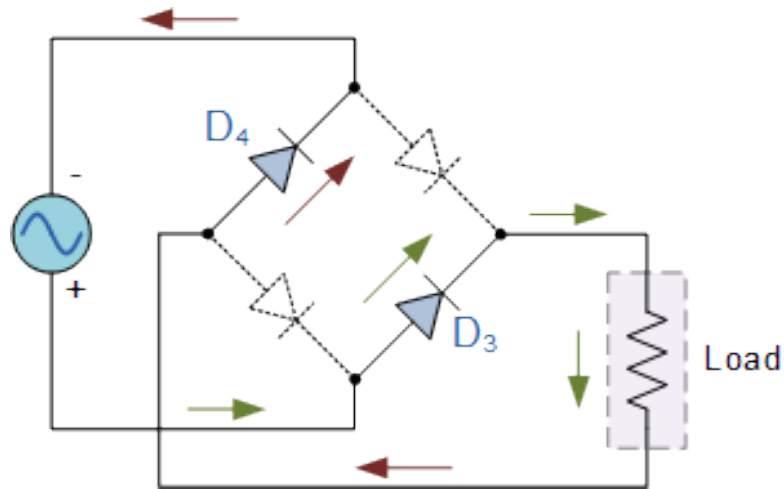

Figure 3.5: The Negative Half-cycle

However in reality, during each half cycle the current flows through two diodes instead of just one so the amplitude of the output voltage is two voltage drops ( $2 \times 0.7 = 1.4\text{V}$ ) less than the input  $V_{\text{MAX}}$  amplitude. The ripple frequency is now twice the supply frequency (e.g. 100Hz for a 50Hz supply or 120Hz for a 60Hz supply.)

Although we can use four individual power diodes to make a full wave bridge rectifier, pre-made bridge rectifier components are available “off-the-shelf” in a range of different voltage and current sizes that can be soldered directly into a PCB circuit board or be connected by spade connectors. The image to the right shows a typical single phase bridge rectifier with one corner cut off. This cut-off corner indicates that the terminal nearest to the corner is the positive or +ve output terminal or lead with the opposite (diagonal) lead being the negative or -ve output lead. The other two connecting leads are for the input alternating voltage from a transformer secondary winding.

### 3.4 The Smoothing Capacitor

When there is a potential difference across the conductors (e.g., when a capacitor is attached across a battery), an electric field develops across the dielectric, causing positive charge (+Q) to collect on one plate and negative charge (-Q) to collect on the other plate. If a battery has been attached to a capacitor for a sufficient amount of time, no current can flow through the capacitor. However, if an accelerating or alternating voltage is applied across the leads of the capacitor, a displacement current can flow.



Figure 3.6: Capacitor

An ideal capacitor is characterized by a single constant value for its capacitance. Capacitance is expressed as the ratio of the electric charge ( $Q$ ) on each conductor to the potential Difference ( $V$ ). The SI unit of capacitance is the farad (F), which is equal to one coulomb per volt ( $1\text{ C/V}$ ). Typical capacitance values range from about  $1\text{ pF}$  ( $10^{-12}\text{ F}$ ) to about  $1\text{ mF}$  ( $10^{-3}\text{ F}$ ). The capacitance is greater when there is a narrower separation between conductors and when the conductors have a larger surface area.

In practice, the dielectric between the plates passes a small amount of leakage current and also has an electric field strength limit, known as the breakdown voltage. The conductors and leads introduce an undesired inductance and resistance. Capacitors are widely used in electronic circuits for blocking direct current while allowing alternating current to pass. In analog filter networks, they smooth the output of power supplies. In resonant circuits they tune radios to particular frequencies. In electric power transmission systems, they stabilize voltage and power flow.

The full-wave bridge rectifier however, gives us a greater mean DC value ( $0.637\text{ V}_{\text{max}}$ ) with less superimposed ripple while the output waveform is twice that of the frequency of the input supply frequency. We can improve the average DC output of the rectifier while at the same time reducing the AC variation of the rectified output by using smoothing capacitors to filter the output waveform. Smoothing or reservoir capacitors connected in parallel with the load across the output of the full wave bridge rectifier circuit increases the average DC output level even higher as the capacitor acts like a storage device as shown

below. Too low a capacitance value and the capacitor has little effect on the output waveform. But if the smoothing capacitor is sufficiently large enough (parallel capacitors can be used) and the load current is not too large, the output voltage will be almost as smooth as pure DC.

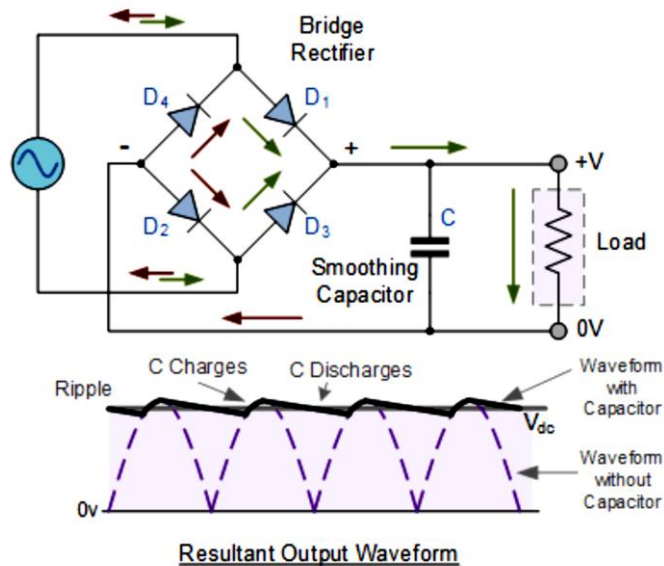

Figure 3.7: The Smoothing Capacitor with Full Bridge Rectifier

### 3.5 Resistor

A resistor is a passive two-terminal electrical component that implements electrical resistance as a circuit element. Resistors act to reduce current flow, and, at the sometime, act to lower voltage levels within circuits. Resistors may have fixed resistances or variable resistances, such as those founding thermostats, visitors, trimmers, photo resistors, hamsters and potentiometers. The current through a resistor is in direct proportion to the voltage across the resistor's terminals. This relationship is represented by Ohm's law.



Figure 3.8: Resistor



Theory of operation:

The behavior of an ideal resistor is dictated by the relationship specified by Ohm 'slaw:

$$V = I.R$$

Ohm's law states that the voltage (V) across a resistor is proportional to the current (I), where the constant of proportionality is the resistance (R).

Equivalently, Ohm's law can be stated:

$$I = V/R$$

This formulation states that the current (I) is proportional to the voltage (V) and inversely proportional to the resistance (R). This is directly used in practical computations. For example, if a 300 ohm resistor is attached across the terminals of a 12 volt battery, then a current of  $12 / 300 = 0.04$  amperes flows through that resistor.

### **3.6 Easy EDA Software**

Easy EDA is a web-based EDA tool suite that enables hardware engineers to design, simulate, share-publicly and privately-and discuss schematics, simulations and printed circuit boards. Other features include the creation of a bill of materials, Gerber files and pick and place files and documentary outputs in PDF, PNG and SVG formats. Easy EDA allows the creation and editing of schematic diagrams, SPICE simulation of mixed analogue and digital circuits and the creation and editing of printed circuit board layouts and, optionally, the manufacture of printed circuit boards.

Subscription-free membership is offered for public plus a limited number of private projects. The number of private projects can be increased by contributing high quality public projects, schematic symbols, and PCB footprints and/or by paying a monthly subscription. Registered users can download Gerber files from the tool free of charge; but for a fee, Easy EDA offers a PCB fabrication service. This service is also able to accept Gerber file inputs from third party tools.

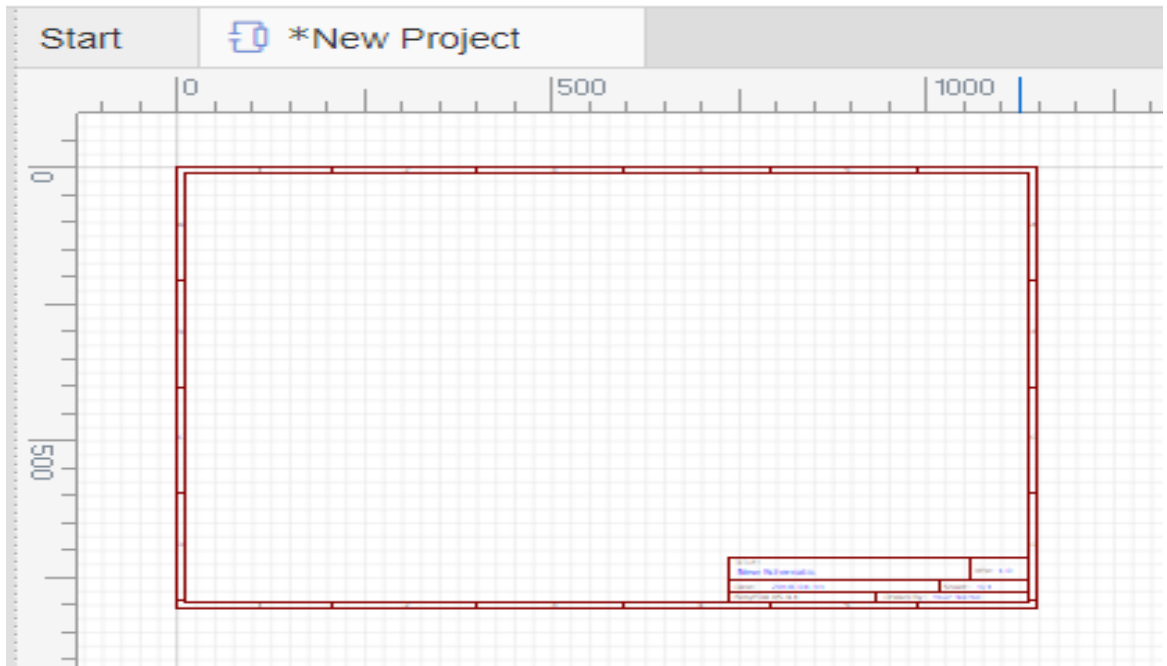

Figure 3.9: Easy EDA Software Interface

## CHAPTER 4 METHODOLOGY

### 4.1 Our methodologies for the project

Our methodologies for the project:

- Creating an idea for Design and Development of Automatic Drain Cleaner System.
- And designing a block diagram & circuit diagram to know which components need to construct it.
- Collecting the all components and programming for the micro controller to controlled the system.
- Setting all components in a PCB board & soldering. Then assembling the all block in a board and finally run the system & checking.

### 4.2 Structural Design

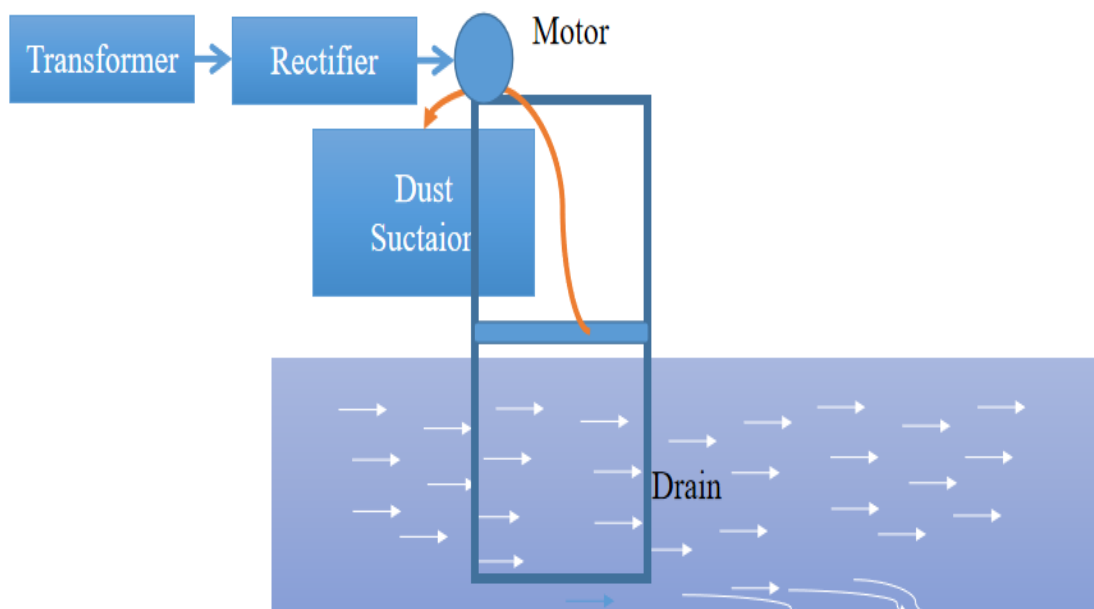

Figure 4.1: Our Project Structural View

### 4.3 Block Diagram

The way of whole project works is that we use AC 220V from the supply voltage and control the all module with the transformer. Here we use Transformer, rectifier circuit, switch and a DC Motor. Here we also use various instrument which is visible in this block diagram.

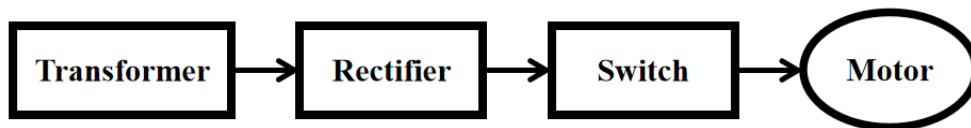

Figure 4.2: Block Diagram of Our System

### 4.4 Schematic Diagram

The schematic diagram here is representing the electrical circuit and the components of the project. Here we have used standardized symbols and lines.

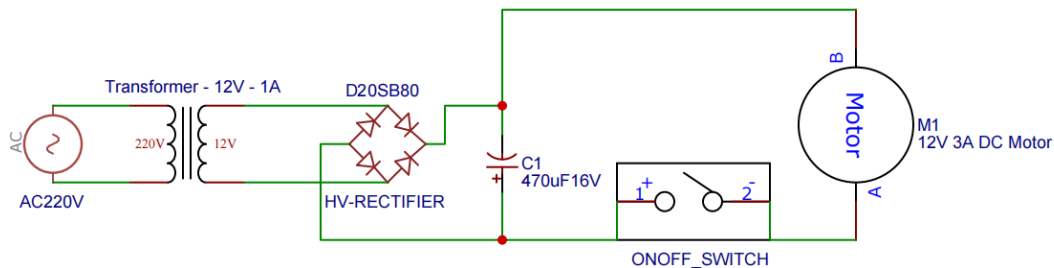

Figure 4.3: Schematic Diagram of the Project

### 4.5 Theory and Working Procedure

The Device is place across drain so that only water flow through lower grids. Waste like bottle, etc. Floating in drain are lifted by teeth which is connected to chain. This chain is attached by gears driven by motor. The energy provided to 220V AC to transformer to motor connected to it. When motor runs the chain starts to circulate making teeth to lift

up. The waste materials are lifted by teeth and are stored in waste storage tank. When we need to of this machine then switch off. In this way the whole system is controlled.

#### **4.6 Final Project View**

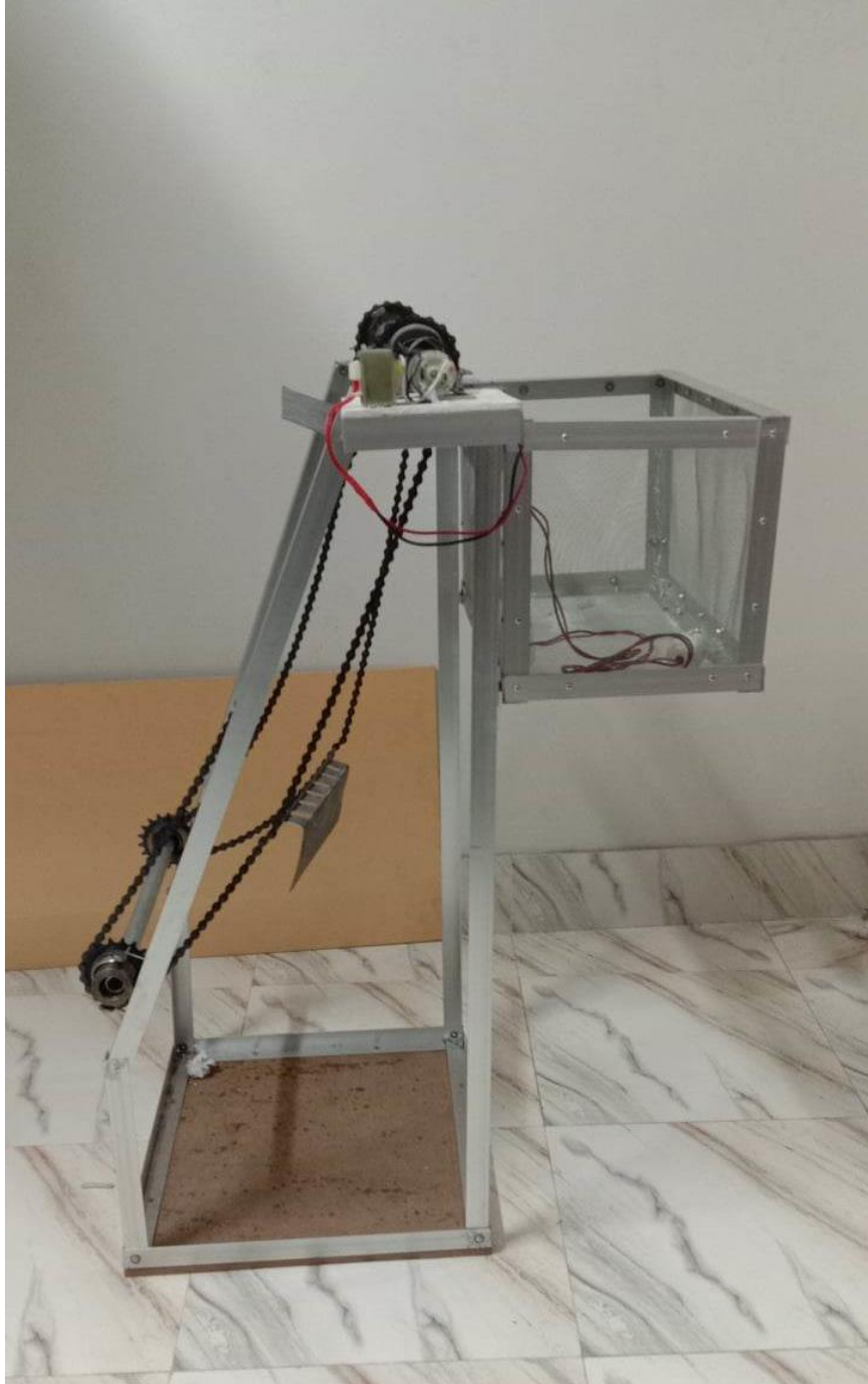

Figure 4.4: Our Final System Overview

## CHAPTER 5 RESULT AND DISCUSSION

### 5.1 Discussion

While working on our project, we did face some difficulties as it is a very complex system but the end results, we came up with were quite satisfactory. We have put the whole system through several tasks to validate our work and also have taken necessary notes for future improvements. Some future recommendations that we have involves improvement in system design and wiring, adding features for more efficient.

### 5.2 Result

Now, it's time to talk about the results. We have written our commands using the Arduino IDE and the following things can happen:

- After power this project then it will be able to operate.
- Then a saw tooth will rotate with a chain.
- Then a motor will such the dust of the water and saw teeth will take it up.
- And store in a tank.

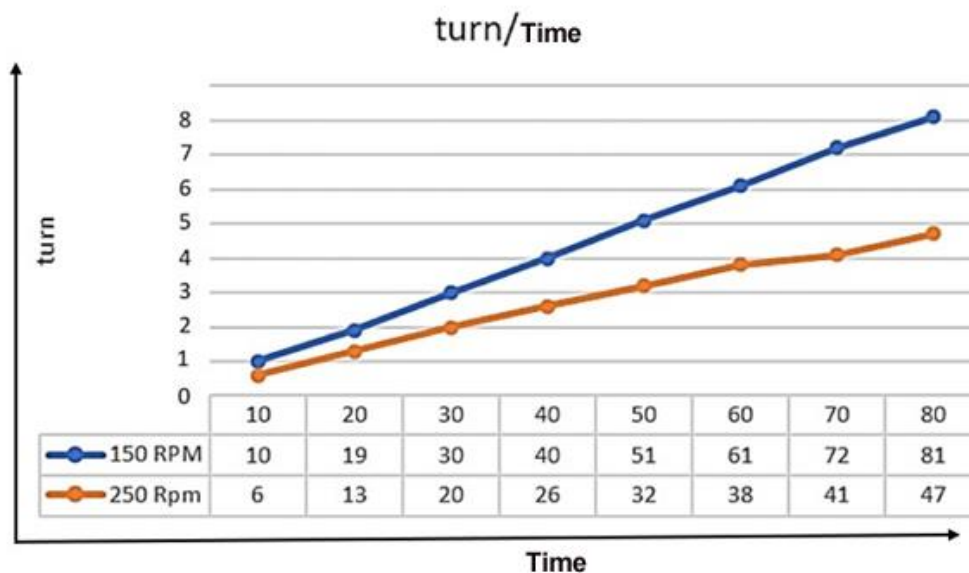

- The graph shows along Time is X-axis and Turn is Y-axis.
- Units are measured in SI system.
- All the measurements are taken in same manners according to SI system

### **5.3 Advantage**

There are many advantages of our project because of its accuracy. Some of the advantages are pointed out below:

- Automatic Cleaning System.
- Automatic Dust Collecting.
- Production cost is very low.
- No need of purchase special machine.
- Its operated and maintenance is simple.
- It is compact and portable.
- It can be efficiently used.

### **5.4 Application**

Some of the application areas of the project have been pointed out below:

- It is used almost in all types of Drainage (Large , Small & medium).
- This machine is mainly used in cleaning system.
- Project to use this in efficient way to control the disposal of wastages and with regular filtration of wastages.

## CHAPTER 6 CONCLUSION

### **6.1 Conclusion**

In the cleaning system of drainage control by the, motor, roller chain and sprocket, lifter and the collecting bin to achieve automatic control system. Automation is a technology concerned with his application of mechanical, electronic and computer based systems to operate and control production. This system is used to operate automatic drain cleaning system. We have followed thoroughly the study of time motion and made our project economical and efficient with the available resources. This system was designed, fabricated successfully and also tested. It works satisfactorily. We hope that this will be done among the most versatile and interchangeable one even in future. Thus we can able to obtain Automatic drain Cleaning system.

### **6.2 Future Scope**

We are thinking about adding many features to our project in the future to get more desirable outcomes. Some of the steps that we are thinking about taking are given below:

- In the future it can be improved by using more sensors.
- In the future, controlling the Internet can be done to improve it



## REFERENCE

- [1] Ganesh U L, et.al. "Semi-Automatic Drain For Sewage Water Treatment Of Floating Materials", International Journal of Research in Engineering and Technology, Vol No- 05, Jul-2016.
- [2] Balachandra, et.al."Automatic Drainage Water Pump Monitoring and Control System Using PLC and SCADA" International Journal of Innovative Research in Technology, Vol No- 1, 2014.
- [3] Dr .K.Kumaresan et.al., "Automatic Sewage Cleaning Equipment", International Conference on Explorations and Innovations in Engineering and Technology , 2016.
- [4] R.Sathiyakala et.al., "Smart Sewage Cleaning System" International Journal of Innovative Research in Computer and Communication Engineering, Vol No- 4, February 2016.
- [5] S D Rahul Bharadwaj, Shraddha R Jogdhankar, "Automatic Wastewater treatment process to reduce global warming" International Journal of Environmental Science: Development and Monitoring, Vol No- 2 (2013)
- [6] Nitin Sall, et.al., "Drain Waste Water Cleaner", Global Journal of Researches in Engineering: J General Engineering Vol No- 16, 2016.
- [7] Nikhil S. Pisal, et.al., "Structural Analysis Of Motorcycle Chain By Using C.A.E. Software", International Journal Of Advance Research In Science and Engineering, Vol No-4, Special Issue (02), February 2015.
- [8] NDUBUISI C. Daniels, "Drainage System Cleaner A Solution to Environmental Hazards", International Referred Journal of Engineering and Science, Vol No- 3, March 2014.
- [9] Shao-Wu-Zhang, "Drainage Device's Research and Development in the Ceramic Filters", Journal of Chemical and Pharmaceutical Research, 2013.

- [10] S.D.Anap, "Wireless Based Water Level Monitoring and Control System", International Advanced Research Journal in Science, Engineering and Technology, Vol No- 3, April 2016.
- [11] James C.Y. Guo, "Winter Sand Recollection By Highway Drainage", ASCE J. of Drainage and Irrigation Engineering, Vol 125, No 6, November 1999.
- [12] James C. Conwell, G.E. Jhonson, "Design, Construction and Instrumentation of a Machine to Measure Tension and Impact Forces in Roller Chain Drives", December 1989.
- [13] N. Prabhushankar et al., "Design and Fabrication of Drainage Cleaning Machine with Spring Return Pneumatic System", International Journal For Scientific Research and Development, Vol No-4, 2016.
- [14] Gregor Burger, et al., "Designing and Implementing a Multi-Core Capable Integrated Urban Drainage Modelling Toolkit: Lessons from CityDrain3", Advances in Engineering Software 100, 2016.
- [15] Ms.T. Deepiga, et al., "Smart Water Monitoring System Using Wireless Sensor Network at Home/Office", International Research Journal of Engineering and Technology, Vol- 02, July-2015.