

# DESIGN AND DEVELOPMENT OF AUTOMATIC BRAKING AND COOLING SYSTEM

By

MD ZAHID HASSAN

KHOKON AHMED

SAKIBUR RAHAMAN SAKIB

MD. MAHBUB HOSSAIN

ZAHID HASAN

A thesis submitted to the Department of Mechanical Engineering in partial fulfillment  
for the degree of Bachelor of Science in Mechanical Engineering



Department of Mechanical Engineering

Sonargaon University

147/I, Green Road, Dhaka-1215, Bangladesh

Section: 17D, Semester 12

Spring-2023

# DESIGN AND DEVELOPMENT OF AUTOMATIC BRAKING AND COOLING SYSTEM

By

Name	ID
MD ZAHID HASSAN	BME-1802015258
KHOKON AHMED	BME-1901017290
SAKIBUR RAHAMAN SAKIB	BME-1802015118
MD. MAHBUB HOSSAIN	BME-1703013313
MD ZAHID HASAN	BME-1901017261

Supervisor

**Md. Mahedy Hasan**

Assistant professor

Department of Mechanical Engineering

SU, Dhaka



A thesis submitted to the Department of Mechanical Engineering in partial fulfillment for the degree of Bachelor of Science in Mechanical Engineering

Department of Mechanical Engineering

Sonargaon University

147/I, Green Road, Dhaka-1215

Bangladesh

Section: 17D, Semester 12

Spring-2023

## BOARD OF EXAMINERS

The thesis titled **Design And Development Of Automatic Braking And Cooling System** Submitted by Md Zahid Hassan , id: BME1802015258; Khokon Ahmed , id: BME1901017290; SakiburRahamanSakib , id: BME1802015118;Md.Mahbub Hossain id :BME1703013313, Md.Zahid Hasan, id:BME1901017261, Section 17D, Spring-2023 which has been accepted as satisfactory in partial fulfilment of the requirement for the degree of Bachelor of Science in Mechanical Engineering on 28th May, 2023.

---

Md. Mahedy Hasan

Assistant professor

Department of Mechanical Engineering

Sonargaon University, Dhaka

## **DECLARATION**

It is hereby declared that except for the contents where specific reference have been made to the work of others, the study contained in this thesis is the result of investigation carried out by the author. No part of this thesis has been submitted to any other university or other educational establishment for a degree, or other qualification.

<b><u>Student's Name</u></b>	<b><u>ID</u></b>	<b><u>Signature</u></b>
MD ZAHID HASSAN	BME1802015258	_____
KHOKON AHMED	BME1901017290	_____
SAKIBUR RAHAMAN SAKIB	BME1802015118	_____
MD. MAHBUB HOSSAIN	BME1703013313	_____
MD. ZAHID HASAN	BME1901017261	_____

*Dedicated*

*to*

*“This thesis has been dedicated our parents and  
teachers”*

## ACKNOWLEDGEMENT

Alhamdulillah. All praises to Allah (SWT) who bestowed His Mercy upon us to complete this work successfully. We wish to express our deepest gratitude to our supervisor, Assistant professor Md. Mahedy Hasan for strongly supporting and trusting us since the beginning of our research. A very special debt of deep gratitude is also due to the author's parents for their continuous encouragement and cooperation during this study. We would like to thank again to the respected Professor Md. Mostofa Hossain, Head of Mechanical Engineering Department. His grant-in-aid for a learning environment is praiseworthy through which we got the opportunity to acquire knowledge under B.Sc. in ME program, and that will be very helpful for our prospective career.

Finally, We are indeed grateful to all those from whom we got sincere cooperation and help for the preparation of this report.

# ABSTRACT

An ultrasonic car braking system includes; an ultrasonic wave emitter provided in a front portion of an automatic braking car producing and emitting ultrasonic waves frontward in a predetermined distance in front of the car. Ultrasonic receiver also formed in a front portion of the car operatively receiving a reflective ultrasonic wave signal as reflected by obstacles positioned within the predetermined distance in front of the automatic braking car. The reflected wave (detection pulse) was measured to get the distance between the vehicle and the obstacle.

Most internal combustion engines are water cooled or a liquid coolant run through a heat exchanger (radiator) cooled by air. In air cooling system, heat is carried away by the air flowing over and around the cylinder. Here fins are cast on the cylinder head and cylinder barrel which provide additional conductive and radiating surface. In water-cooling system of cooling engines, the cylinder walls and heads are provided with jacket through which the cooling liquid can circulate. An internal combustion engine produces power by burning fuel within the cylinders; therefore, it is often referred to as a "heat engine." However, only about 25% of the heat is converted to useful power. What happens to the remaining 75 percent? Thirty to thirty-five percent of the heat produced in the combustion chambers by the burning fuel are dissipated by the cooling system along with the lubrication and fuel systems. Forty to forty-five percent of the heat produced passes out with the exhaust gases. If this heat were not removed quickly, overheating and extensive damage would result. Valves would burn and warp, lubricating oil would break down, pistons and bearing would overheat and seize, and the engine would soon stop. The necessity for cooling may be emphasized by considering the total heat developed by an ordinary six-cylinder engine.

# Table of Contents

BOARD OF EXAMINERS .....	<b>Error! Bookmark not defined.</b>
DECLARATION.....	vi
DEDICATED TO .....	<b>Error! Bookmark not defined.</b>
ACKNOWLEDGEMENT .....	vii
ABSTRACT.....	<b>Error! Bookmark not defined.</b>
LIST OF FIGURES .....	xii
CHAPTER 1 .....	1
INTRODUCTION .....	1
1.1 Background .....	1
1.2 Objective .....	1
1.3 Methodology .....	2
1.4 Engine Water Cooling System.....	3
CHAPTER 2 .....	3
LITERATURE REVIEW .....	3
2.1 Literature Review.....	3
2.2 Engine Cooling System.....	3
2.2.1 Components of a Cooling System.....	4
2.3 The Fundamental of Ultrasonic Sensor.....	7
2.4 Ultrasonic Sensing/Control Basics .....	8
2.5 Basic of Ultrasonic Sensor .....	8
2.6 Measurement Principle/Effective Use of Ultrasonic Sensor .....	8
2.7 The advantages of Ultrasonic Sensor.....	9
2.8 The Disadvantages of Ultrasonic Sensor .....	9
2.9 Target Angle and Beam Spread .....	10
2.10 Beam Spread .....	10
2.11 Environmental Factors Effect to Ultrasonic Sensor Performance .....	10
2.11.1Temperature .....	10



2.11.2 Air Turbulence and Convection Currents .....	10
2.11.3 Atmospheric Pressure .....	11
2.11.4 Humidity .....	11
2.11.5 Acoustic Interference .....	11
2.12 Radio Frequency Interference.....	11
2.13 Splashing Liquids.....	12
2.14 Sensor's Target Considerations .....	12
2.15 Shape.....	12
2.16 Target Orientation to Sensor.....	12
2.17 Function of Arduino Nano .....	13
2.17.1 Defining Arduino .....	13
2.17.2 Arduino Architecture: .....	14
2.17.3 Arduino Pin Diagram.....	15
2.17.4 Steps to Program an Arduino .....	17
2.17.5 Few Basic Functions of Arduino .....	17
2.17.6 Designing the Arduino.....	18
2.17.7 Reasons why Arduino is being preferred these days? .....	18
CHAPTER 3 .....	19
SYSTEM DESIGN .....	19
3.1 Working Principle.....	19
3.2 Circuit Diagram of Auto Breaking System.....	21
3.3 Block Diagram of Auto Breaking System .....	22
3.4 List of Components With Price.....	23
3.5 How an Engine Cooling System Works .....	24
3.5.1 Ultrasonic Transmitter .....	25
3.5.2 Ultrasonic Receiver.....	25
3.6 Braking Circuit.....	26
3.6.1 Reset Circuit.....	29
3.6.2 Crystal Circuit.....	30

3.7 Ultrasonic Ranging Circuit .....	30
3.7.1 Transmitter.....	31
3.7.2 Receiver .....	31
3.7.3 Operation.....	31
3.8 LCD Display .....	32
3.9 Construction and Working Principle of LCD Display.....	32
3.9.1 What is a LCD (Liquid Crystal Display)? .....	32
3.9.2 How LCDs are Constructed? .....	33
3.9.3 How LCDs Work? .....	34
3.9.4 Advantages of an LCD's:.....	35
3.9.5 Disadvantages of an LCD's: .....	35
3.9.6 Applications of Liquid Crystal Display .....	35
3.10 Capacitor .....	36
3.11 Resistor .....	36
3.12 Theory of Operation.....	37
3.13 LED.....	38
3.13.1 Introduction.....	38
3.13.2 Overview.....	39
3.13.3 Working Principle.....	40
3.13.4 Advantages.....	40
3.13.5 Disadvantages .....	41
3.13.6 Applications .....	41
3.14 Diode (1N4007) .....	42
3.15 Battery.....	42
3.15.1 Introduction.....	43
3.15.2 Overview.....	43
3.15.3 Working Principle.....	44
Chapter- 4.....	45
RESULT AND DISCUSSION .....	45

4.1 Introduction.....	45
4.2 Result .....	46
4.3 Advantages.....	49
4.4 Disadvantages .....	49
Chapter-5.....	50
CONCLUSION.....	50
5.1 Conclusion .....	50
REFERENCES:-.....	55

## List of Figures

Figure 1. 1 Methodology of our project.....	2
Figure 2. 1 Basic ultrasonic Operation.....	9
Figure 2. 2 Overview of Arduino nano.....	14
Figure 2. 3 Arduino structure.....	15
Figure 2. 4 Arduino pinout.....	15
Figure 2. 5 Arduino interfacing .....	16
Figure 3. 1 Circuit diagram.....	17

Figure 3. 2 Block diagram.....	22
Figure 3. 3 List of components with price .....	23
Figure 3. 4 Ultrasonic sensor .....	25
Figure 3. 5 Flow chart.....	26
Figure 3. 6 Block diagram .....	28
Figure 3. 7 Ultrasound distance measurements .....	28
Figure 3. 8 Ultrasound sensor .....	29
Figure 3. 9 Rest connection of ultrasonic sensor .....	30
Figure 3. 10 16x2 LCD connection.....	32
Figure 3. 11 Simple facts that should be considered while making an LCD:.....	33
Figure 3. 12 Capacitor.....	36
Figure 3. 13 Resistor .....	37
Figure 3. 14 Symbol of LED.....	38
Figure 3. 15 LED .....	39
Figure 3. 16 Circuit of LED.....	40
Figure 3. 17 Diode (1N4007).....	42
Figure 3. 18 (a) Current flow is permitted; the diode is forward biased. (b) Current flow is prohibited; the diode is reversed biased.....	42
Figure 3. 19 Lithium-ion battery.....	43
Figure 3. 20 Circuit of lithium battery .....	44
Figure 4. 1 Overview of our project .....	49

# CHAPTER 1

## INTRODUCTION

### 1.1 Background

Driving is a compulsory activity for most people. People use their car to move from one place to other place. The number of vehicles are increasing day by day. It is produced tacked tightly and risk to accident. Nowadays, the numbers of accident is so high and uncertainly. Accident will occurs every time and everywhere and cause worst damage, serious injury and dead. These accidents are mostly cause by delay of the driver to hit the brake. This project is designed to develop a new system that can solve this problem where drivers may not brake manually but the vehicles can stop automatically due to obstacles. This project is about a system that can control braking system for safety. Using ultrasonic as a ranging sensor, its function based on ultrasonic wave. After transmit by transmitter, the wave can reflect when obstacle detected and receive by receiver. The main target for this project is, cars can automatically brake due to obstacles when the sensor senses the obstacles. The braking circuit function is to brake the car automatically after received signal from the sensor.

### 1.2 Objective

The objectives of this project are: To develop a safety car braking system using ultrasonic sensor and temperature control water Colling system.

#### SCOPE OF PROJECT

- i. To develop an ultrasonic sensor to detect the obstacle
- ii. To process the output from the ultrasonic sensor to Arduino microcontroller for control motor power.
- iii. To process the output from the temperature sensor to Arduino microcontroller for control water pump and fan.
- iv. Reduce over heating issue of engine.

### 1.3 Methodology

1. First the requirements of the project was carefully analyzed to design the home automation system.
2. The methodology of this project design can be divided into two sections; hardware and software implementations.
3. Information's were collected from references books and websites to find out the possible improvement.
4. Required components have been purchased from local market.

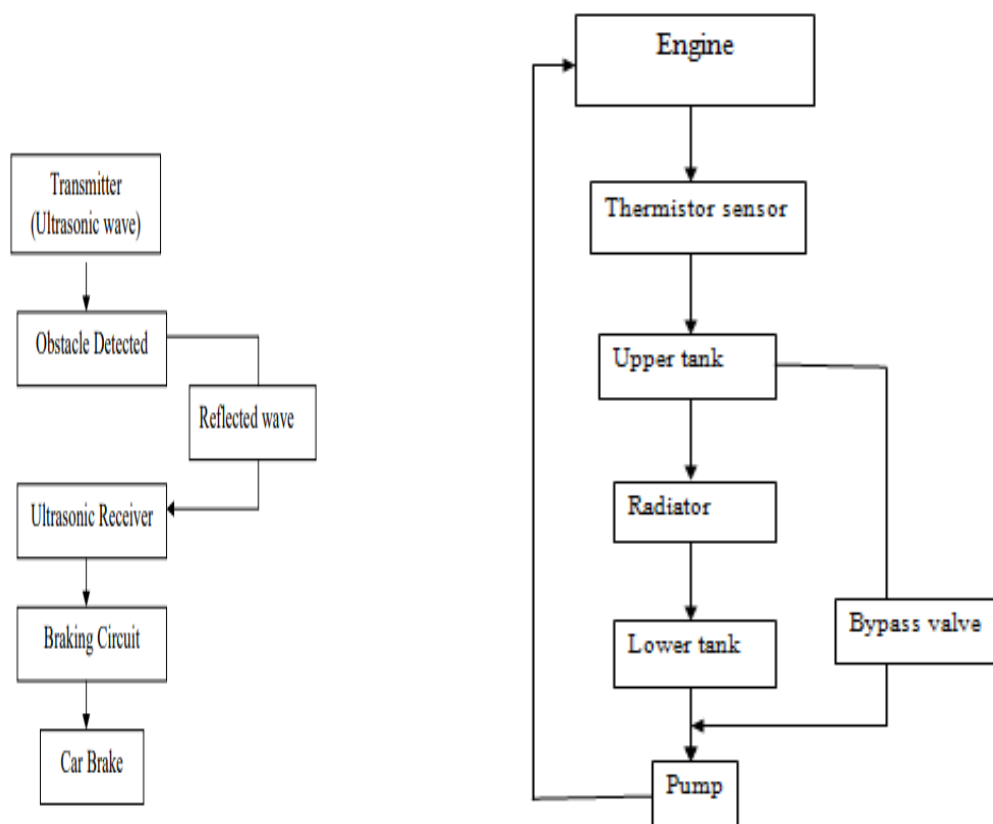

Figure 1. 1 Methodology of our project

## **1.4 Engine Water Cooling System**

A cooling water system should be used when the process heat is available at a low temperature (below 60°C), no more easily exploited, and the process outlet temperature must be lower than the ambient air temperature. This is the reason why it's common to use an air cooler with a water cooler downstream; the temperature limit between the air cooler outlet and the water cooler inlet is the one indicated above.

The aforementioned temperature ranges shall be taken as a reference for selecting the appropriate cooling system. They depend on on-site conditions; the edge temperature value could be shown in Client documentation (BEDD). Site conditions limit the design options and the possible ways to operate the cooling system. They are defined by the local climate, the availability of water for cooling and discharge, the available space for construction, and the surrounding area's sensitivity to emissions.

# **CHAPTER 2**

## **LITERATURE REVIEW**

### **2.1 Literature Review**

This chapter reviews some of the work related to the study of the ultrasonic car braking system. The main reviews are about sensor, ultrasonic sensor, PIC microcontroller and servo motor.

### **2.2 Engine Cooling System**

The engine in your car works best at a high temperature. When the engine is cold, components wear out easily, emits more pollutants, and the engine becomes less efficient. Thus, another important task of the cooling system is to allow the engine to warm up as quickly as possible, and then to maintain a constant engine temperature. The main function of a cooling system is to ensure that the engine runs at its optimum operating temperature. If the cooling system or any part of it fails, it will overheat the engine, which can lead to many serious issues.

Have you ever imagined what would happen if your engine cooling system did not work properly? Overheating can cause cylinder head gaskets to explode and even crack engine blocks if the problem is serious enough. And all this heat must be fought. If the heat cannot be removed from the engine, the pistons are literally welded to the inside of the cylinders. Then you just must throw the engine away and buy a new one. So, you should take care of your engine cooling system and learn how it works.

## **2.2.1 Components of a Cooling System**

### **Radiator**

The radiator acts as a heat exchanger for the engine. It is usually made of aluminium and has many small diameter pipes with fins attached to them. Furthermore, it exchanges the heat of the hot water coming from the engine with the ambient air. It also has a drainage plug, an inlet port, a sealed cover, and an outlet port.

### **Construction of Radiator**

The construction of radiator can vary depending on its specific application, but generally, it consists of the following components:

1. Core : The core is the heart of the radiator and is made up of a series of a small tubes that run horizontally between two tanks. The tubes are often made of aluminum or copper, and they are surrounded by thin metal fins that help to increase the surface area for heat transfer.
2. Tanks: The tanks are located at the top and bottom of the radiator and are used to hold the coolant. They are usually made of plastic or aluminum and are connected to the core by a series of hoses or pipes.
3. Inlet and Outlet : The inlet and outlet are located at the top and bottom of the radiator and are used to circulate the coolant through the engine. The inlet and outlet are usually connected to the engine by a series of hoses or pipes.
4. Fans: Some radiators have fans mounted on them to increase the airflow and improve cooling performance. The fans are usually mounted behind the core and are powered by an electric motor.
5. Mounting Brackets: Radiators are usually mounted to the vehicle or structure using brackets. The brackets are usually made of metal and are designed to hold the radiator securely in place.



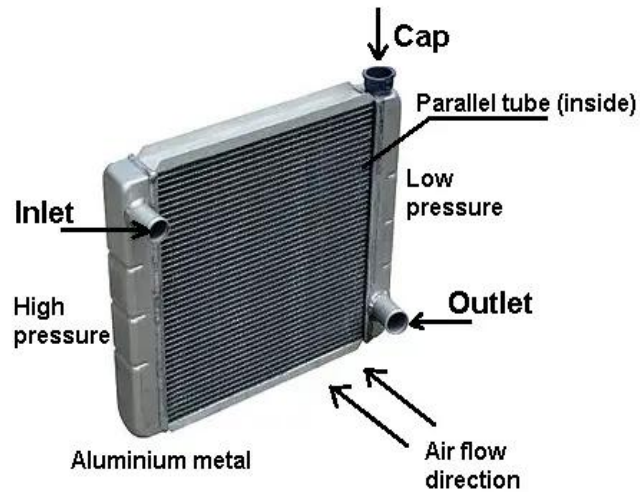

Figure 2.1 Radiator

### **Radiator Working Principle**

The radiator working is very simple. In radiator , the coolant flows from the inlet to the outlet through many tubes mounted in a parallel arrangement. The hot water enters the radiator through the inlet port. And a fan is attached on behind the radiator to cool down the hot water in the tubes. The fan blows the air and cools down the water. So the water is going to come out cooler than it entered before and then go back to the engine .

### **Water pump**

DOLZ produces and distributes water pumps for automobiles and industrial vehicles to be sold on the independent aftermarket, following the most demanding quality standards and, complying with OEM specifications (original references). Equivalent to OE Quality (art. 1 Block Exemption Regulation EC 1400/2002).

We manufacture more than 5.5 million units per year over a range which comprises:

- Water pumps for passenger cars
- Water pumps for industrial vehicles
- Auxiliary electric water pumps
- Variable water pumps
- Electric water pumps



Figure 2.2 5V DC Water pump

### **Thermistor Sensor**

Thermistors are temperature-dependent resistors, changing resistance with changes in temperature. They are very sensitive and react to very small changes in temperature. They are best used when a specific temperature needs to be maintained, and when monitoring temperatures within 50°C of ambient.



Figure 2.3 Thermistor sensor

## **Thermistor Sensor Working Principle**

The thermistor works on the simple principle of change in resistance due to a change in temperature. When the ambient temperature changes the thermistor starts self-heating its elements. its resistance value is changed with respect to this change in temperature. This change depends on the type of thermistor used.

## **2.3 The Fundamental of Ultrasonic Sensor**

Ultrasonic ranging and detecting devices use high-frequency sound waves to detect the presence of an object and its range. The systems either measure the echo reflection of the sound from objects or detect the interruption of the sound beam as the objects pass between the transmitter and receiver.

An ultrasonic sensor typically utilizes a transducer that produces an electrical output in response to received ultrasonic energy. The normal frequency range for human hearing is roughly 20 to 20,000 hertz. Ultrasonic sound waves are sound waves that are above the range of human hearing and, thus, have a frequency above about 20,000 hertz. Any frequency above 20,000 hertz may be considered ultrasonic.

Most industrial processes, including almost all source of friction, create some ultrasonic noise. The ultrasonic transducer produces ultrasonic signals. These signals are propagated through a sensing medium and the same transducer can be used to detect returning signals.

Ultrasonic sensors typically have a piezoelectric ceramic transducer that converts an excitation electrical signal into ultrasonic energy bursts. The energy bursts travel from the ultrasonic sensor, bounce off objects, and are returned toward the sensor as echoes. Transducers are devices that convert electrical energy to mechanical energy, or vice versa. The transducer converts received echoes into analog electrical signals that are output from the transducer.

The piezoelectric effect refers to the voltage produced between surfaces of a solid dielectric (non-conducting substance) when a mechanical stress is applied to it. Conversely when a voltage is applied across certain surfaces of a solid that exhibits the piezoelectric effect, the solid undergoes a mechanical distortion. Such solids typically resonate within narrow frequency ranges. Piezoelectric materials are used in transducers, e.g., phonograph cartridges, microphones, and strain gauges that produce an electrical output from a mechanical input. They are also used in earphones and ultrasonic transmitters that produce a mechanical output from an electrical input.

Ultrasonic transducers operate to radiate ultrasonic waves through a medium such as air. Transducers generally create ultrasonic vibrations through the use of piezoelectric materials such as certain forms of crystal or ceramic polymers.

## **2.4 Ultrasonic Sensing/Control Basics**

Ultrasonic signals are like audible sound waves, except the frequencies are much higher. Our ultrasonic transducers have piezoelectric crystals which resonate to a desired frequency and convert electric energy into acoustic energy and vice versa. The illustration shows how sound waves, transmitted in the shape of a cone, are reflected from a target back to the transducer. An output signal is produced to perform some kind of indicating or control function. A minimum distance from the sensor is required to provide a time delay so that the "echoes" can be interpreted. Variables which can effect the operation of ultrasonic sensing include, target surface angle, reflective surface roughness or changes in temperature or humidity. The targets can have any kind of reflective form - even round objects.

## **2.5 Basic of Ultrasonic Sensor**

The ultrasonic transducer produces ultrasonic signal. These signals are propagated through a sensing medium and the same transducer can be used to detect returning signals. In most applications, the sensing medium is simply air. An ultrasonic sensor typically comprises at least one ultrasonic transducer which transforms electrical energy into sound and in reverse sound into electrical energy, a housing enclosing the ultrasonic transducer, an electrical connection and optionally, an electronic circuit for signal for signal processing also enclosed in the housing.

## **2.6 Measurement Principle/Effective Use of Ultrasonic Sensor**

Ultrasonic sensor transmits ultrasonic waves from its sensor head and again receives the ultrasonic waves reflected from an object. By measuring the length of time from the transmission to reception of the sonic wave, it detects the position of the object.

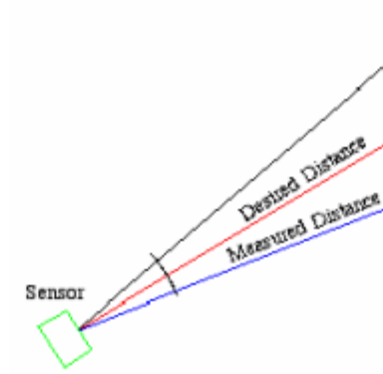
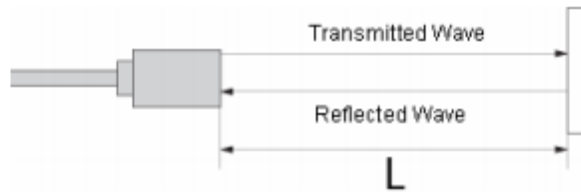

Figure 2. 4 Basic ultrasonic operation

## 2.7 The Advantages of Ultrasonic Sensor

Ultrasonic have a lot of advantages for using in real application. The advantages of ultrasonic sensor are:

- i. Discrete distances to moving objects can be detected and measured. Resistance to external disturbances such as vibration, infrared radiation, ambient noise, and EMI radiation.
- ii. Measures and detects distances to moving objects.
- iv. Impervious to target materials, surface and color.
- v. Solid-state units have virtually unlimited, maintenance free lifespan.
- vi. Detects small objects over long operating distance.
- vii. Ultrasonic sensors are not affected by dust, dirt or high moisture environments.

## 2.8 The Disadvantages of Ultrasonic Sensor

Some disadvantages of ultrasonic sensor are:

- i. Overheating of a wave emitter precludes the energy of ultrasonic waves emitted there from being enhanced to a practical level.
- ii. Interference between the projected waves and the reflected waves takes place, and development of standing waves provides adverse effects.
- iii. It is impossible to discern between reflected waves from the road surface and reflected waves from other places or objects.

## **2.9 Target Angle and Beam Spread**

**Target Angle** This term refers to the "tilt response" limitations of a given sensor. Since ultrasonic sound waves reflect off the target object, target angles indicate acceptable amounts of tilt for a given sensor.

## **2.10 Beam Spread**

This term is defined as the area in which a round wand will be sensed if passed through the target area. This is the maximum spreading of the ultrasonic sound as it leaves the transducer.

## **2.11 Environmental Factors Effect to Ultrasonic Sensor Performance**

### **2.11.1 Temperature**

The velocity of sound in air is 13,044 in./s at 0 C, it is directly proportional to air temperature. As the ambient air temperature increases, the speed of sound also increases. Therefore if a fixed target produces an echo after a certain time delay, and if the temperature drops, the measured time for the echo to return increases, even though the target has not moved. This happens because the speed of sound decreases, returning an echo more slowly than at the previous, warmer temperature. If varying ambient temperatures are expected in a specific application, compensation in the system for the change in sound speed is recommended.

### **2.11.2 Air Turbulence and Convection Currents**

A particular temperature problem is posed by convection currents that contain many bands of varying temperature. If these bands pass between the sensor and the target, they will abruptly

change the speed of sound while present. No type of temperature compensation (either temperature measurement or reference target) will provide complete high-resolution correction at all times under these circumstances. In some applications it may be desirable to install shielding around the sound beam to reduce or eliminate variations due to convection currents. Averaging the return times from a number of echoes will also help reduce the random effect of convection currents. Users addressing applications requiring high accuracy and resolution should evaluate these suggestions carefully.

### **2.11.3 Atmospheric Pressure**

Normal changes in atmospheric pressure will have little effect on measurement accuracy. Reliable operation will deteriorate however, in areas of unusually low air pressure, approaching a vacuum.

### **2.11.4 Humidity**

Humidity does not significantly affect the operation of an ultrasonic measuring system. Changes in humidity do have a slight effect, however, on the absorption of sound. If the humidity produces condensation, sensors designed to operate when wet must be used.

### **2.11.5 Acoustic Interference**

Special consideration must be given to environments that contain background noise in the ultrasonic frequency spectrum. For example, air forced through a nozzle, such as air jets used for cleaning machines, generates a whistling sound with harmonics in the ultrasonic range. When in close proximity to a sensor, whether directed at the sensor or not, ultrasonic noise at or around the sensor's frequency may affect system operation. Typically, the level of background noise is lower at higher frequencies, and narrower beam angles work best in areas with a high ultrasonic background noise level. Often a baffle around the noise source will eliminate the problem. Because each application differs, testing for interference is suggested.

## **2.12 Radio Frequency Interference**

Another possible source of noise is RFI emitting from SCR's in a variable speed drive. Shielding around the back and sides of the transducer may prevent RFI noise from entering the system.

## **2.13 Splashing Liquids**

Splashing liquids should be kept from striking the surface of the sensor, both to protect the sensor from damage if it is not splash proof and to ensure an open path for the sound energy to travel.

## **2.14 Sensor's Target Considerations**

Composition Nearly all targets reflect ultrasonic sound and therefore produce an echo that can be detected. Some textured materials produce a weaker echo, reducing the maximum effective sensing range. The reflectivity of an object is often a function of frequency. Lower frequencies can have reduced reflections from some porous targets, while higher frequencies reflect well from most target materials. Precise performance specifications can often be determined only through experimentation.

## **2.15 Shape**

A target of virtually any shape can be detected ultrasonically if sufficient echo returns to the sensor. Targets that are smooth, flat, and perpendicular to the sensor's beam produce stronger echoes than irregularly shaped targets. A larger target relative to sound wavelength will produce a stronger echo than a smaller target until the target is larger than approximately 10 wavelengths across. Therefore, smaller targets are better detected with higher frequency sound. In some applications a specific target shape such as a sphere, cylinder, or internal cube corner can solve alignment problems between the sensor and the target.

## **2.16 Target Orientation to Sensor**

To produce the strongest echoes, the sensor's beam should be pointed toward the target. If a smooth, flat target is inclined off perpendicular, some of the echo is deflected away from the sensor and the strength of the echo is reduced. Targets that are smaller than the spot diameter of the transducer beam can usually be inclined more than larger targets. Sensors with larger beam angles will generally produce stronger echoes from flat targets that are not perpendicular to the axis of the sound beam. Sound waves striking a target with a coarse, irregular surface will diffuse and reflect in many directions. Some of the reflected energy may return to the sensor as a weak but measurable echo. As always, target suitability must be evaluated for each application.

Servo Motor Operation The servo motor has some control circuits and a potentiometer (a variable resistor) that is connected to the output shaft. In the picture above, the pot can be seen



on the right side of the circuit board. This pot allows the control circuitry to monitor the current angle of the servo motor. If the shaft is at the correct angle, then the motor shuts off. If the circuit finds that the angle is not correct, it will turn the motor the correct robots direction until the angle is correct. The output shaft of the servo is capable of travelling somewhere around 180 degrees. Usually, it is somewhere in the 210 degree range, but it varies by manufacturer. A normal servo 15 is used to control an angular motion of between 0 and 180 degrees. A normal servo is mechanically not capable of turning any farther due to a mechanical stop built on to the main output gear.

The amount of power applied to the motor is proportional to the distance it needs to travel. So, if the shaft needs to turn a large distance, the motor will run at full speed. If it needs to turn only a small amount, the motor will run at a slower speed. This is called proportional control. The control wire is used to communicate the angle. The angle is determined by the duration of a pulse that is applied to the control wire. This is called Pulse Coded Modulation. The servo expects to see a pulse every 20 milliseconds (.02 seconds). The length of the pulse will determine how far the motor turns. A 1.5 millisecond pulse, for example, will make the motor turn to the 90 degree position (often called the neutral position). If the pulse is shorter than 1.5 ms, then the motor will turn the shaft to closer to 0 degrees. If the pulse is longer than 1.5ms, the shaft turns closer to 180 degrees. From the figure above, the duration of the pulse dictates the angle of the output shaft (shown as the green circle with the arrow). Note that the times here are illustrative and the actual timings depend on the motor manufacturer. The principle, however, is the same.

## **2.17 Function of Arduino Nano**

### **2.17.1 Defining Arduino**

An Arduino is actually a microcontroller based kit which can be either used directly by purchasing from the vendor or can be made at home using the components, owing to its open source hardware feature. It is basically used in communications and in controlling or operating many devices. It was founded by Massimo Banzi and David Cuartielles in 2005.

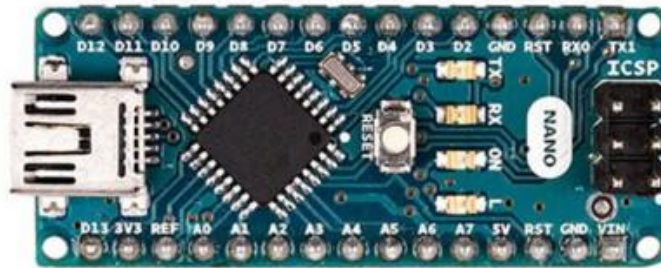

Figure 2. 5 Overview of arduino nano

### **2.17.2 Arduino Architecture:**

Arduino's processor basically uses the Harvard architecture where the program code and program data have separate memory. It consists of two memories- Program memory and the data memory. The code is stored in the flash program memory, whereas the data is stored in the data memory. The Atmega328 has 32 KB of flash memory for storing code (of which 0.5 KB is used for the bootloader), 2 KB of SRAM and 1 KB of EEPROM and operates with a clock speed of 16MHz.

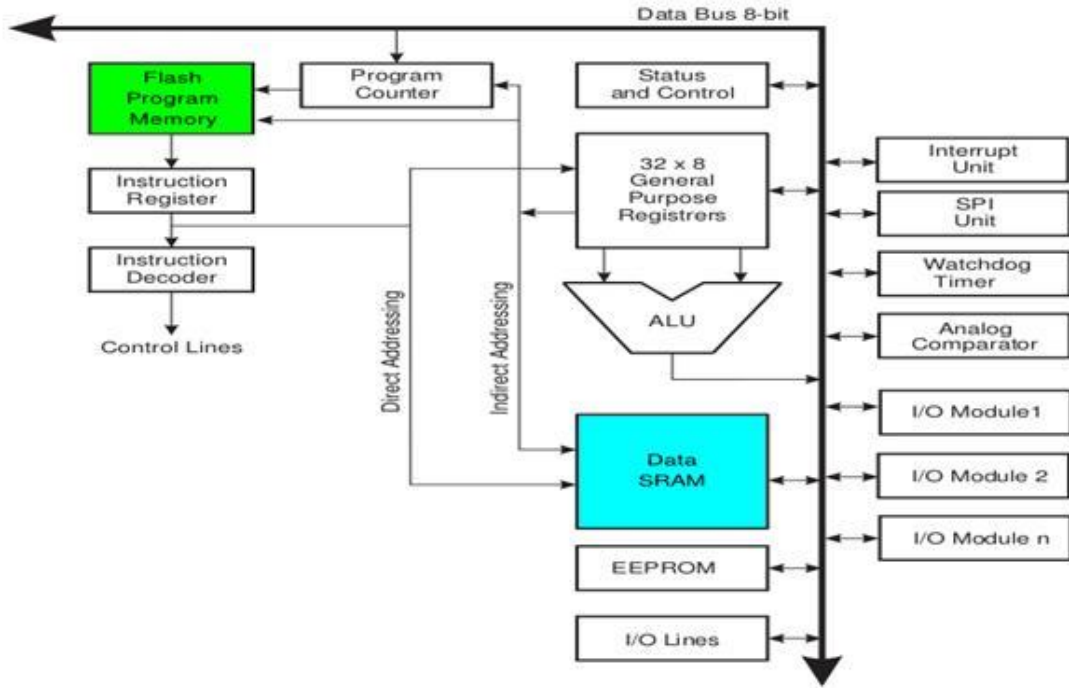

Figure 2. 6 Arduino structure

### 2.17.3 Arduino Pin Diagram

A typical example of Arduino board is Arduino Uno. It consists of ATmega328- a 30 pin microcontroller.

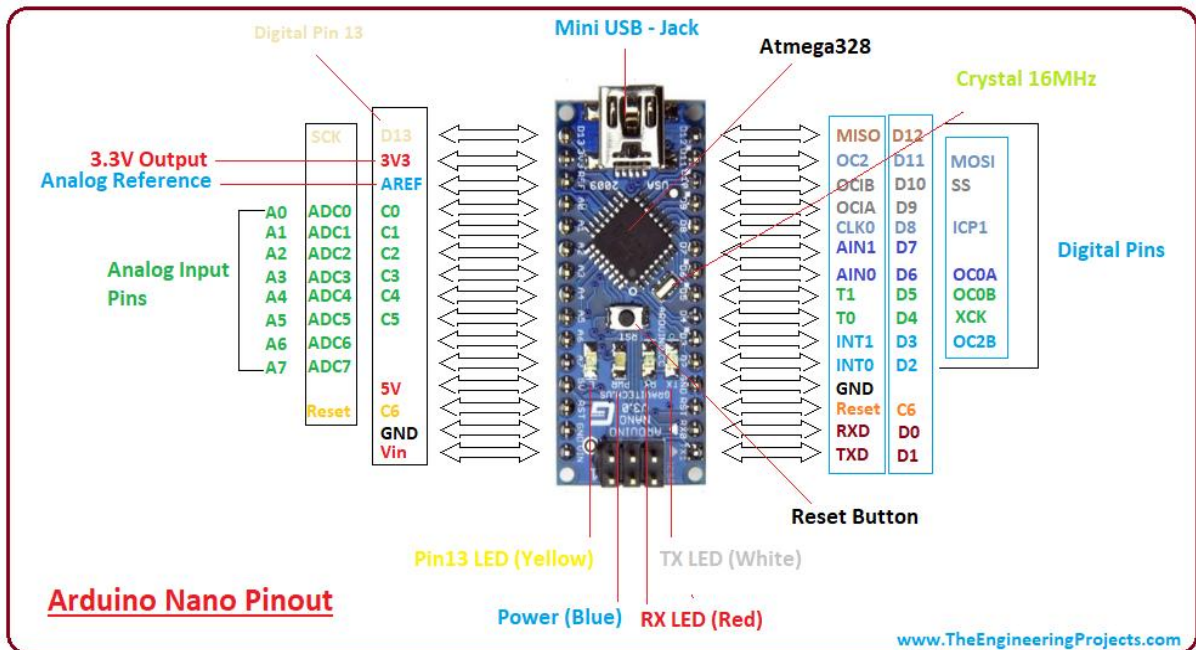

Figure 2.7 Arduino pinout

**Power Jack:** Arduino can be power either from the pc through a USB or through external source like adaptor or a battery. It can operate on a external supply of 7 to 12V. Power can be applied externally through the pin Vin or by giving voltage reference through the IOREf pin.

**Digital Inputs:** It consists of 15 digital inputs/output pins, each of which provide or take up 40mA current. Some of them have special functions like pins 0 and 1, which act as Rx and Tx respectively , for serial communication, pins 2 and 3-which are external interrupts, pins 3,5,6,9,11 which provides pwm output and pin 13 where LED is connected.

**Analog inputs:** It has 6 analog input/output pins, each providing a resolution of 10 bits.

**ARef:** It provides reference to the analog inputs

**Reset:** It resets the microcontroller when low.

How to program an Arduino?

The most important advantage with Arduino is the programs can be directly loaded to the device without requiring any hardware programmer to burn the program.

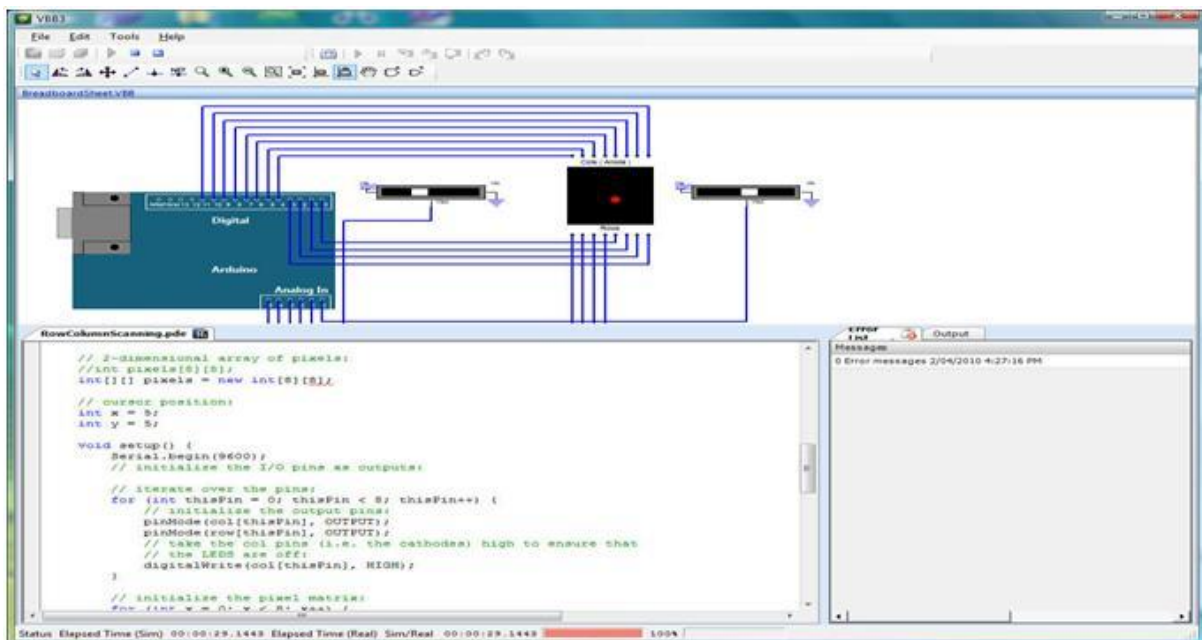

Figure 2. 8 Arduino interfacing

This is done because of the presence of the 0.5KB of Bootloader which allows the program to be burned into the circuit. All we have to do is to download the Arduino software and writing the code.

The Arduino tool window consists of the toolbar with the buttons like verify, upload, new, open, save, serial monitor. It also consists of a text editor to write the code, a message area which displays the feedback like showing the errors, the text console which displays the output and a series of menus like the File, Edit, Tools

### **2.17.4 Steps to Program an Arduino**

Programs written in Arduino are known as sketches. A basic sketch consists of 3 parts

1. Declaration of Variables
2. Initialization: It is written in the setup () function.
3. Control code: It is written in the loop () function.

The sketch is saved with .in extension. Any operations like verifying, opening a sketch, saving a sketch can be done using the buttons on the toolbar or using the tool menu.

The sketch should be stored in the sketchbook directory.

Chose the proper board from the tools menu and the serial port numbers.

Click on the upload button or chose upload from the tools menu. Thus the code is uploaded by the bootloader onto the microcontroller.

### **2.17.5 Few Basic Functions ofAdruino**

**digitalRead**(pin): Reads the digital value at the given pin.

**digitalWrite**(pin, value): Writes the digital value to the given pin.

**pinMode**(pin, mode): Sets the pin to input or output mode.

**analogRead**(pin): Reads and returns the value.

**analogWrite**(pin, value): Writes the value to that pin.

**serial.begin**(baud rate): Sets the beginning of serial communication by setting the bit rate.

### **2.17.6 Designing the Arduino .**

- We can also design our own Arduino by following the schematic given by the Arduino vendor and also available at the websites. All we need are the following components- A breadboard, a led, a power jack, a IC socket, a microcontroller, few resistors, 2 regulators, 2 capacitors.
- The IC socket and the power jack are mounted on the board.
- Add the 5v and 3.3v regulator circuits using the combinations of regulators and capacitors.
- Add proper power connections to the microcontroller pins.
- Connect the reset pin of the IC socket to a 10K resistor.
- Connect the crystal oscillators to pins 9 and 10
- Connect the led to the appropriate pin.
- Mount the female headers onto the board and connect them to the respective pins on the chip.
- Mount the row of 6 male headers, which can be used as an alternative to upload programs.
- Upload the program on the Microcontroller of the readymade Arduino and then pry it off and place back on the user kit

### **2.17.7 Reasons why Arduino is being preferred these days?**

1. It is inexpensive
2. It comes with an open source hardware feature which enables users to develop their own kit using already available one as a reference source.
3. The Arduino software is compatible with all types of operating systems like Windows, Linux, and Macintosh etc.
4. It also comes with open source software feature which enables experienced software developers to use the Arduino code to merge with the existing programming language libraries and can be extended and modified.
5. It is easy to use for beginners.
6. We can develop an Arduino based project which can be completely stand alone or projects which involve direct communication with the software loaded in the computer.
7. It comes with an easy provision of connecting with the CPU of the computer using serial communication over USB as it contains built in power and reset circuitry.

# CHAPTER 3

## SYSTEM DESIGN

### 3.1 Working Principle

Braking systems of commercial vehicles were always given the highest importance concerning safety issues and in particular active safety. Inappropriate braking of these vehicles may cause heavy accidents due to relatively longer stopping distances and higher energy output of brakes particularly in the case of vehicle combinations. The traditional medium used for brake system (compressed air) can be now controlled with the speed and precision offered by modern electronic abilities. Intelligent Braking System (IBS) introduced in commercial vehicles providing rapid brake response and release for every single wheel therefore ensuring safety. The extremely rapid response time provided by the electronic control can be used for crucially shortening the braking distance by introducing advanced control of braking system operation. Such a complex task imposed to the control of braking system cannot be based on the driver abilities and need to be done independently of the driver. An improved IBS braking forces management would certainly enable to reach the given task. The advanced strategy for the braking force management, proposed here, is based on intelligent controlling of the braking forces distribution between the front and rear axle of power-driven vehicle and/or between towing/trailer combination and/or between tractor/semi-trailer. Intelligent braking system has a lot of potential applications especially in developed countries where research on smart vehicle and intelligent highway are receiving ample attention. The system when integrated with other subsystems like automatic traction control system, intelligent throttle system, and auto cruise system, etc. will result in smart vehicle manoeuvre. The driver at the end of the day will become the passenger, safety accorded the highest priority and the journey will be optimized in term of time duration, cost, efficiency and comfortability. The impact of such design and development will cater for the need of contemporary society that aspires quality drive as well as to accommodate the advancement of technology especially in the area of smart sensor and actuator. The emergence of digital signal processor enhances the capacity and features of universal microcontroller. The overall system is designed so that the value of inter-vehicle distance from infrared laser sensor and speed of follower car from speedometer are fed into the DSP for

processing, resulting in the DSP issuing commands to actuator to function appropriately [1]. The most popular systems like Antilock Braking Systems (ABS), Traction Control and Stability Control employ different types of sensors to constantly monitor the conditions of the vehicle, and respond in an emergency situation. An intelligent mechatronic system includes an ultrasonic wave emitter provided on the front portion of a car producing and emitting ultrasonic waves frontward in a predetermined distance. An ultrasonic receiver is also placed on the front portion of the car operatively receiving a reflective ultrasonic wave signal. The reflected wave (detected pulse) gives the distance between the obstacle and the vehicle. Then a microcontroller is used to control the speed of the vehicle based on the detection pulse information to push the brake pedal and apply brake to the car stupendously for safety purpose.

The function of engine cooling system is to keep the engine within the proper temperature range under all operating conditions. The cooling system must prevent the engine from overheating and prevent the engine from being too cold in winter. After the engine is cold-started, the cooling system also ensures that the engine heats up quickly and reaches the normal operating temperature as quickly as possible. The cooling system is an important system to maintain the normal temperature of the engine and ensure the normal operation of the engine.

The cooling system is composed of various parts: the radiator, pressure cap, fan, pump, thermostat, hoses and overflow tank. The pump sends cooling fluid to the engine where it absorbs the engine's heat. After exiting the engine, it runs by a thermostat. If the cooling fluid is below the maximum temperature, the thermostat stays closed and the fluid is re-routed back to the pump. However, if the fluid is overheated, the thermostat's valve opens, routing the fluid through a radiator first. The radiator cools the fluid by releasing its heat to the air before returning it to the pump.

Cars can have a liquid cooling system or an air cooling system, although most modern cars are liquid-cooled. With a cooling system based on liquid, fluid contained in pipes passes through the engine, absorbing heat while cooling the engine. If the fluid gets overheated, it's routed through the radiator, which acts as a heat exchanger, releasing the surplus heat to the air. On the other hand, a cooling system based on air has aluminum fins surrounding the engine. When the engine gets overheated, fans blow air over the fins to conduct the heat away from the engine's cylinder, cooling it down.

Engines are heated in a similar way when starting up the car. The pump starts the process by sending fluid through the engine. As the fluid leaves the engine, if it hasn't reached the minimum temperature, it needs to pass through a heater core before being re-routed to the pump.



### 3.2 Circuit Diagram of Auto Breaking System

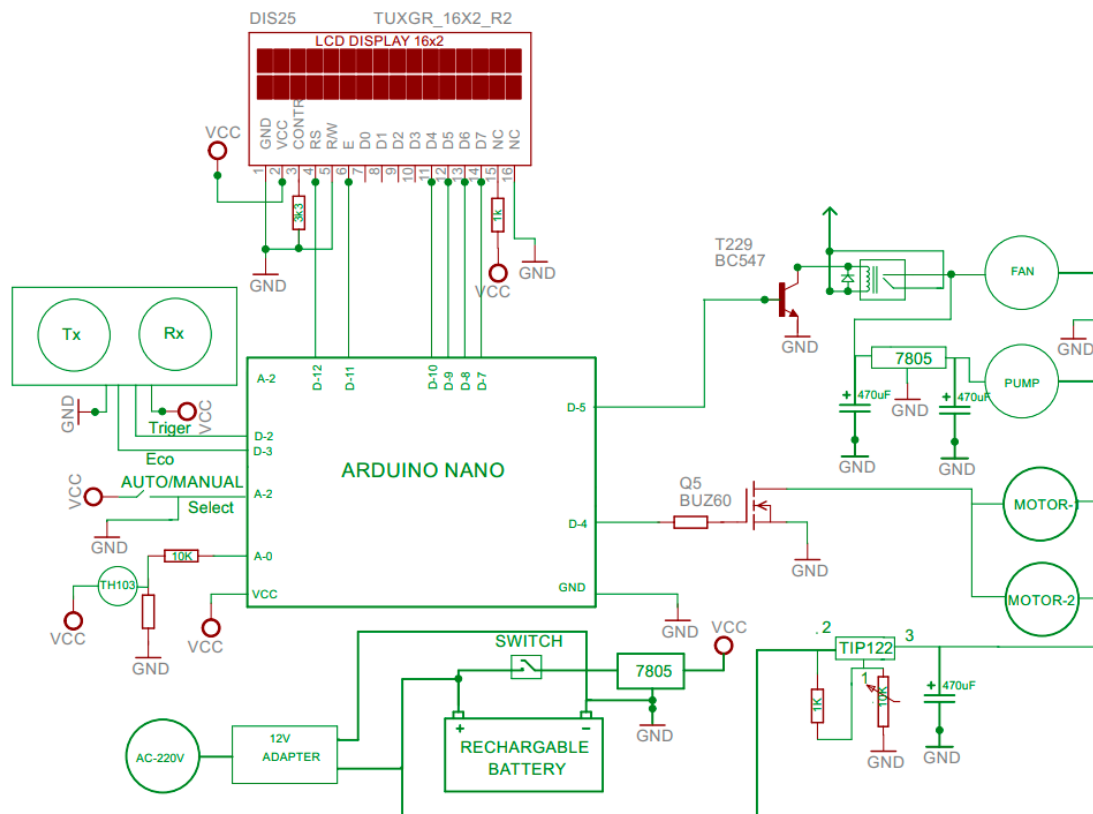

Ac  
Go

Figure 3. 1 Circuit diagram

### 3.3 Block Diagram of Auto Breaking System

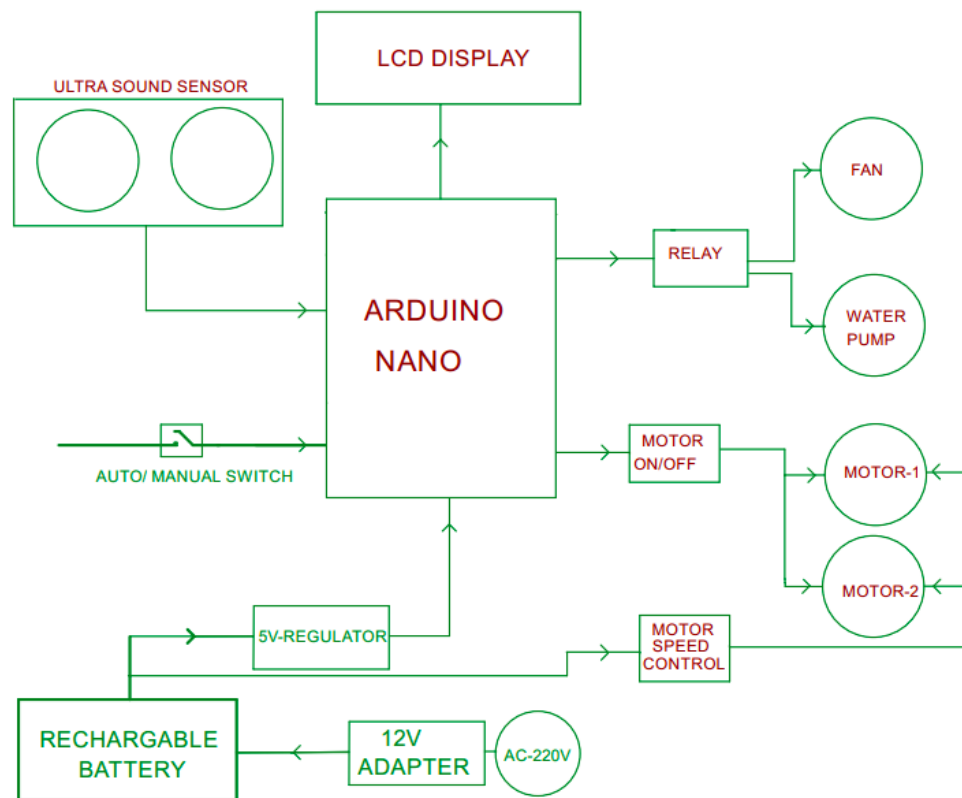

Figure 3. 2 Block diagram

### 3.4 List of Components With Price

SL	COMPONENTS NAME	QTY	PRICE
	ARDUINO NANO	1	350
	16X2 LCD DISPLAY	1	200
	ULTRA SOUND SENSOR	1	200
	L293D MOTOR DRIVER IC	1	150
	MOTOR	2	300
	WIRE	4	500
	RECHARGABLE BATTERY	3	450
	12V TRANSFORMER	1	150
	BUZZER	1	20
	DIODE	5	20
	CAPACITOR	5	30
	RESISTOR	11	200
	LED	2	60
	PUSH SWITCH	2	20
	POWER SWITCH	1	20
	7805 REGULATOR	1	30
	AC CORD	1	50
	PCB BOARD	1	100
	PROJECTS STRUCTURE	1	300
	5V DC WATER PUMP	1	145
	12V COOLING FAN	1	90
	TRANSISTOR	1	05
	N-CHANNEL MOSFET	1	35
	VARIABLE	2	10
<b>TOTAL PRICE</b>			<b>3435/-</b>

Figure 3. 3 List of components with price

### **3.5 How an Engine Cooling System Works**

To explain how a cooling system works, it must firstly explain what it does. It's very simple – the car's cooling system cools the engine. But cooling this engine can seem like a gigantic task, especially when you consider how much heat a car engine generates. Think about it. The engine of a small car traveling on a highway at 50 miles per hour will generate approximately 4,000 explosions per minute.

Along with all the friction from moving parts, this is a lot of heat that needs to be concentrated in one place. Without an efficient cooling system, the engine will heat up and stop running within minutes. A modern cooling system should ensure the coolness of the car at an ambient temperature of 115 degrees, as well as warmth in the winter weather.

Dolz is a European company that adheres to a set of standards in terms of innovation, efficiency, reliability, and sustainability in its worldwide sourcing solutions that help their partners and customers move water pumps where needed. With more than 80 years of history, IndustriasDolz is a worldwide leader in manufacturing water pumps with a wide range of products adding distribution kits and thermostats for the spare parts industry.

#### **What Happens Inside?**

The cooling system works by constantly passing coolant through channels in the engine block. Coolant, driven by a water pump, is pushed through the cylinder block. As the solution passes through these channels, it absorbs heat from the engine.

Leaving the engine, this heated fluid enters the radiator, where it is cooled by the air flow entering through the car's radiator grill. The fluid will cool as it passes through the radiator, returning to the engine again to pick up more engine heat and carry it away.

There is a thermostat between the radiator and engine. Depending on the temperature, the thermostat regulates what happens to the liquid. If the fluid temperature drops below a certain level, the solution bypasses the radiator and is instead directed back to the engine block. The coolant will continue to circulate until it reaches a certain temperature and opens the valve on the thermostat, allowing it to pass through the radiator again for cooling.

It seems that due to the very high engine temperature, the coolant can easily reach its boiling point. However, the system is under pressure to prevent this from happening. When the system is under pressure, it is much more difficult for the coolant to reach its boiling point. Occasionally, however, pressure builds up and must be relieved before it can deflate the hose or gasket. The

radiator cap relieves excess pressure and fluid by accumulating in the reserve tank. After the liquid in the storage tank has cooled to an acceptable temperature, it is returned to the cooling system for re-circulation.

### 3.5.1 Ultrasonic Transmitter

Before transmit the ultrasonic wave, there is a part which is ultrasonic wave generator that function to generate ultrasonic wave. In that part, there is timing instruction means for generating an instruction signal for intermittently providing ultrasonic waves. This signal will send to an ultrasonic wave generator for generating ultrasonic waves based on the instruction signal from said timing instruction means (transform electrical energy into sound wave). After ultrasonic wave was produced, ultrasonic transmitter transmits the ultrasonic waves toward a road surface to find out the obstacle. The range that obstacle detected is depends on the range of ultrasonic sensors that used.



Figure 3. 4 Ultrasonic sensor

### 3.5.2 Ultrasonic Receiver

If the ultrasonic wave detect the obstacle, its will produce a reflected wave. An ultrasonic receiver is used for receiving the ultrasonic waves reflected from the road surface to generate a

reception signal. There is ultrasonic transducer that will transform back the sound wave to electrical energy. This signal amplified by an amplifier. The amplified signal is compared with reference signal to detect components in the amplified signal due to obstacles on the road surface. The magnitude of the reference signal or the amplification factor of the amplifier is controlled to maintain a constant ratio between the average of the reference signal and the average of the amplified signal.

### 3.6 Braking Circuit

The processed signal will be send to the braking circuit. At the braking circuit, there is a controller that can process the signal and give the instruction to the output based on condition of the signal. For this project, controller that used Arduino Nano.

Arduino Nano use the high language and easy to do the programming.

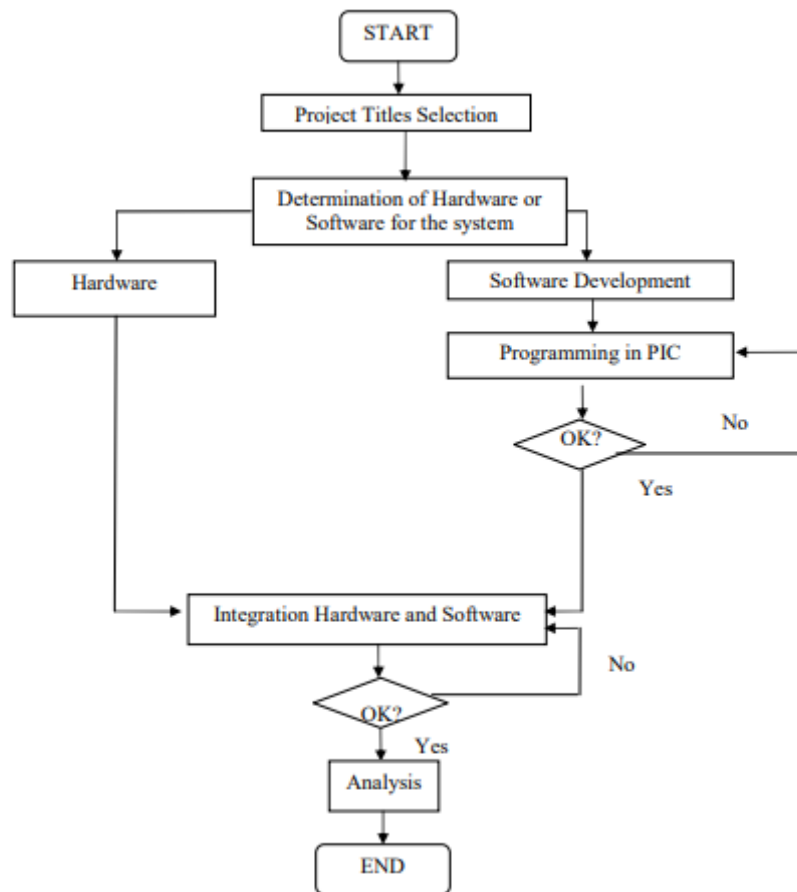

Figure 3. 5 Flow chart of development

Figure 3.5 above is shown about Flow Chart of Development of this project. Once, the title of this project Ultrasonic Car Braking System is selected. The identifying and understanding

process was done. In this process, I found out all notes and information related to the project. The process was divided into two main groups which are software and hardware development. For the software development, the controller that prefers is PIC16F84A microcontroller (8-bit microcontroller). Therefore all programming must suitable and match with this controller. The process of software development is continuously done until get the perfect resulted. For the hardware development, the focus is to develop the circuit and board for PIC16F84A microcontroller. Besides, focus is to develop ultrasonic circuit to implement to this project. After that, we must do the connection between ultrasonic sensor (transmitter & receiver), PIC16F84A microcontroller and lastly motor for the output. The process of Integration Hardware and Software is very important because to interface the software and hardware is so hard. Although, the simulations will right output, it is not perfect for the real situation. The problem will exist after we try to interface both. So, doing analysis is compulsory to correct the software or hardware so that we can get the right result.

The AT89S52 is a low-power, high-performance CMOS 8-bit microcontroller with 8K bytes of in-system programmable Flash memory. The device is manufactured Mistreatment Atmel's high-density non-volatile memory technology and is compatible with the industry-standard 80C51 instruction set and pin out. The on -chip Flash allows the program memory to be reprogrammed in-system or by a Typical non-volatile memory pro-grammar. By combining a versatile 8-bit CPU with in-system programmable Flash on a monolithic chip, the Atmel AT89S52 is

Powerful microcontroller which provides a highly-flexible and efficient resolution to several embedded management applications.

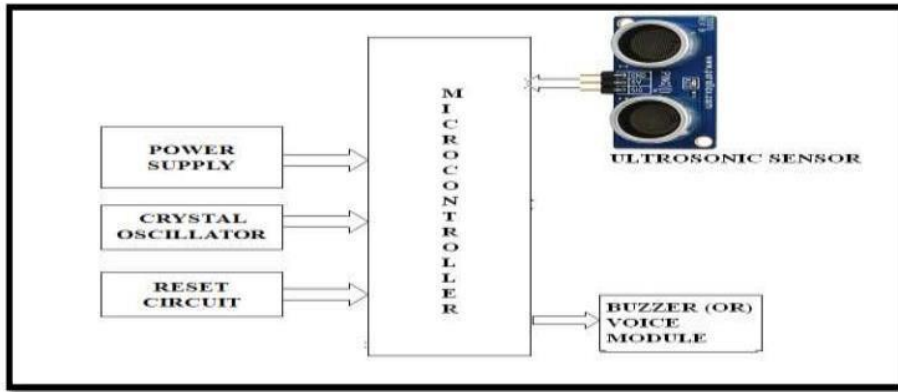

Figure 3. 6 Block diagram

When signals from the sensors of sound circuit, playback circuit or vibrator circuit have been detected, it will be transmitted to an extra circuit connected thereto, in order to activate the specified output. The operation of ultrasonic sensing element is as shown in Fig.3.7

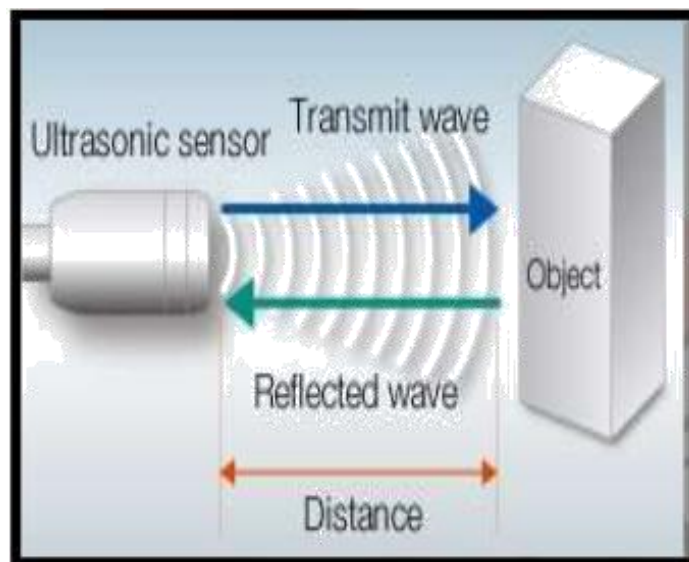

Figure 3. 7 Ultrasound Distance Measurements



The main part within the system is that the microcontroller that controls the opposite Components of the system. When the supersonic sensors discover any objects or obstacles in 180 degree horizontal, it will activate the buzzer mechanically.

The Ultrasonic sensing element is as shown in Fig.3.8.



Figure 3. 8 Ultrasound Sensor

Buzzer is an audio signaling device which may be mechanical, Electromechanical or piezoelectric. Typical uses of buzzers include alarm device, timers

### 3.6.1 Reset Circuit

Reset is used for putting the microcontroller into a 'known' condition. That practically means that microcontroller will behave rather inaccurately below certain undesirable conditions. In order to continue its proper functioning

it has to be reset, meaning all registers would be placed in a beginning position. Reset is not only used once microcontroller does not behave the way we want it To, but can also be used when trying attempt out a device as an interrupt in program Execution, or to get a microcontroller ready once loading a program. In order to Stop from bringing a logical zero

to MCLR pin accidentally, MCLR has to be Connected via resistor to the positive provide pole and capacitor from MCLR to The bottom. Resistor should be between 5 and 10K and the capacitor can be in Between 1 $\mu$ f tp 10 $\mu$ f. This kind of resistor capacitor combination, gives the rc time Delay for the  $\mu$ c to reset.

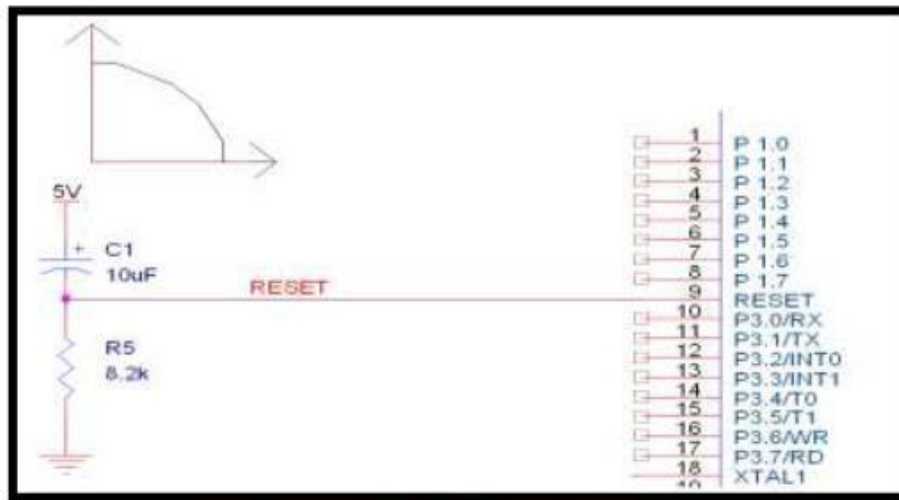

Figure 3. 9 Rest connection of ultrasonic sensor

### 3.6.2 Crystal Circuit

Pins OSC1 & OSC2 are provided for connecting a resonant network to form oscillator. Typically a quartz crystal and capacitors are employed. Here we are connecting twp ceramic capacitors which are basically used for filtering. In other words to give a pure square wave to the  $\mu$ C we are connecting the two capacitors. The basic rule for placing the crystal on the board is that it should be as close to the  $\mu$ C as possible to avoid any interference in the clock.

### 3.7 Ultrasonic Ranging Circuit

For this circuit, it can be divided into several parts, which are process to produced ultrasonic wave part, transmitter part, receiver part, amplifier part and lastly output part.

### 3.7.1 Transmitter

The supply circuit is needed to supply a short 10 $\mu$ s pulse to the trigger input to start the ranging. The sensor will send out an 8 cycle burst of ultrasound at 40 kHz and raise its echo line high. It then listens for an echo, and as soon as it detects one it lowers the echo line again. The echo line is therefore a pulse whose width is proportional to the distance to the object. By timing the pulse it is possible to calculate the range in inches/centimeters or anything else. If nothing is detected then the sensor will lower its echo line anyway after about 36 ms. It uses a PIC12C508 to perform the control functions and standard 40 kHz piezo transducers. The drive to the transmitting transducer could be simplest driven directly from the PIC. The transducer can handle 20V of drive the transmitting wave.

A MAX232 IC, usually used for RS232 communication makes an ideal driver, providing about 16V of drive.

### 3.7.2 Receiver

The receiver is a classic two stage op-amp circuit. The input capacitor C8 blocks some residual DC which always seems to be present. Each gain stage is set to 24 for a total gain of 576-ish. This is close to the 25 maximum gain available using the LM1458. The gain bandwidth product for the LM1458 is 1 MHz. The maximum gain at 40 kHz is  $1000000/40000 = 25$ . The output of the amplifier is fed into an LM311 comparator. A small amount of positive feedback provides some hysteresis to give a clean stable output.

A convenient negative voltage for the op-amp and comparator is generated by the MAX232. Unfortunately, this also generates quite a bit of high frequency noise, therefore shut it down whilst listening for the echo. The 10 $\mu$ F capacitor C9 holds the negative rail just long enough to do this.

### 3.7.3 Operation

In operation, the processor waits for an active low trigger pulse to come in. It then generates just eight cycles of 40 kHz. The echo line is then raised to signal the host processor to start timing. The raising of the echo line also shuts off the MAX232. After a while (no more than 10-12ms normally), the returning echo will be detected and the PIC will lower the echo line. The width of this pulse represents the flight time of the sonic burst. If no echo is detected

then it will automatically time out after about 30ms (it is two times the WDT period of the PIC). Because the MAX232 is shut down during echo detection, you must wait at least 10ms between measurement cycles for the +/- 10V to recharge.

### 3.8 LCD Display

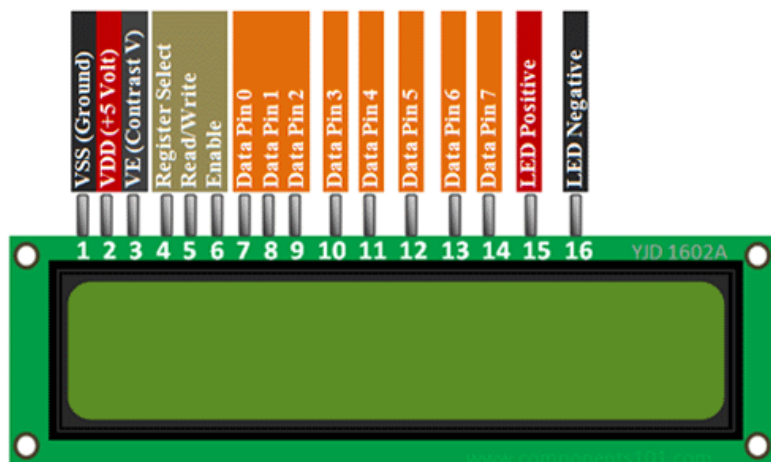

Figure 3.10 16x2 LCD connection

- LCD (Liquid Crystal Display) screen is an electronic display module
- These modules are preferred over seven segments and other multi segment LEDs
- LCDs are economical

### 3.9 Construction and Working Principle of LCD Display

#### 3.9.1 What is aLCD (Liquid Crystal Display)?

A liquid crystal display or LCD draws its definition from its name itself. It is combination of two states of matter, the solid and the liquid. LCD uses a liquid crystal to produce a visible image. Liquid crystal displays are super-thin technology display screen that are generally used in laptop computer screen, TVs, cell phones and portable video games. LCD's technologies allow displays to be much thinner when compared to cathode ray tube (CRT) technology.

Liquid crystal display is composed of several layers which include two polarized panel filters and electrodes. LCD technology is used for displaying the image in notebook or some other electronic devices like mini computers. Light is projected from a lens on a layer of liquid crystal. This combination of colored light with the grayscale image of the crystal (formed as electric current flows through the crystal) forms the colored image. This image is then displayed on the screen.

An LCD is either made up of an active matrix display grid or a passive display grid. Most of the Smartphone's with LCD display technology uses active matrix display, but some of the older displays still make use of the passive display grid designs. Most of the electronic devices mainly depend on liquid crystal display technology for their display. The liquid has a unique advantage of having low power consumption than the LED or cathode ray tube.

Liquid crystal display screen works on the principle of blocking light rather than emitting light. LCD's requires backlight as they do not emits light by them. We always use devices which are made up of LCD's displays which are replacing the use of cathode ray tube. Cathode ray tube draws more power compared to LCD's and are also heavier and bigger.

### 3.9.2 How LCDs are Constructed?

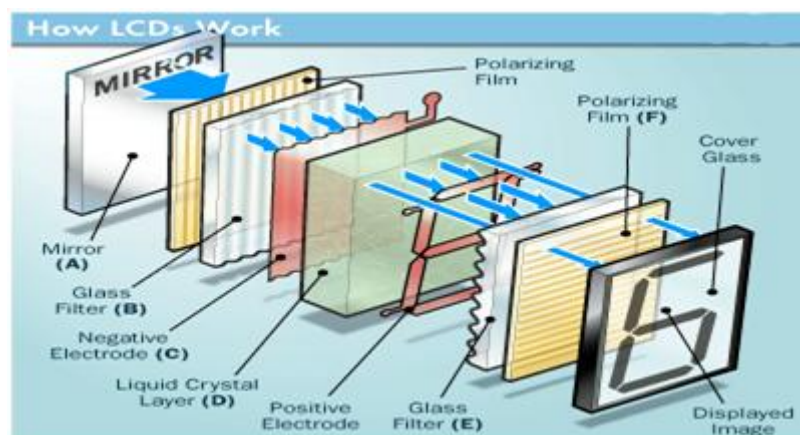

Figure 3. 11 Simple facts that should be considered while making an LCD:

- The basic structure of LCD should be controlled by changing the applied current.
- We must use a polarized light.
- Liquid crystal should be able to control both of the operation to transmit or can also be able to change the polarized light.

As mentioned above that we need to take two polarized glass pieces filter in the making of the liquid crystal. The glass which does not have a polarized film on the surface of it must be rubbed with a special polymer which will create microscopic grooves on the surface of the polarized glass filter. The grooves must be in the same direction of the polarized film. Now we have to add a coating of pneumatic liquid phase crystal on one of the polarized filter of the polarized glass. The microscopic channel cause the first layer molecule to align with filter orientation. When the right angle appears at the first layer piece, we should add a second piece of glass with the polarized film. The first filter will be naturally polarized as the light strikes it at the starting stage.

Thus the light travels through each layer and guided on the next with the help of molecule. The molecule tends to change its plane of vibration of the light in order to match their angle. When the light reaches to the far end of the liquid crystal substance, it vibrates at the same angle as that of the final layer of the molecule vibrates. The light is allowed to enter into the device only if the second layer of the polarized glass matches with the final layer of the molecule.

### **3.9.3 How LCDs Work?**

The principle behind the LCD's is that when an electrical current is applied to the liquid crystal molecule, the molecule tends to untwist. This causes the angle of light which is passing through the molecule of the polarized glass and also cause a change in the angle of the top polarizing filter. As a result a little light is allowed to pass the polarized glass through a particular area of the LCD. Thus that particular area will become dark compared to other. The LCD works on the principle of blocking light. While constructing the LCD's, a reflected mirror is arranged at the back. An electrode plane is made of indium-tin oxide which is kept on top and a polarized glass with a polarizing film is also added on the bottom of the device. The complete region of the LCD has to be enclosed by a common electrode and above it should be the liquid crystal matter.

Next comes to the second piece of glass with an electrode in the form of the rectangle on the bottom and, on top, another polarizing film. It must be considered that both the pieces are kept at right angles. When there is no current, the light passes through the front of the LCD it will be reflected by the mirror and bounced back. As the electrode is connected to a battery the current from it will cause the liquid crystals between the common-plane electrode and the electrode shaped like a rectangle to untwist. Thus the light is blocked from passing through. That particular rectangular area appears blank.

### **3.9.4 Advantages of an LCD's:**

- LCD's consumes less amount of power compared to CRT and LED
- LCD's are consist of some microwatts for display in comparison to some mill watts for LED's
- LCDs are of low cost
- Provides excellent contrast
- LCD's are thinner and lighter when compared to cathode ray tube and LED

### **3.9.5 Disadvantages of an LCD's:**

- Require additional light sources
- Range of temperature is limited for operation
- Low reliability
- Speed is very low
- LCD's need an AC drive

### **3.9.6 Applications of Liquid Crystal Display**

- Liquid crystal technology has major applications in the field of science and engineering as well on electronic devices.
- Liquid crystal thermometer
- Optical imaging
- The liquid crystal display technique is also applicable in visualization of the radio frequency waves in the waveguide
- Used in the medical applications

### 3.10 Capacitor

When there is a potential difference across the conductors (e.g., when a capacitor is attached across a battery), an electric field develops across the dielectric, causing positive charge (+Q) to collect on one plate and negative charge (-Q) to collect on the other plate. If a battery has been attached to a capacitor for a sufficient amount of time, no current can flow through the capacitor. However, if an accelerating or alternating voltage is applied across the leads of the capacitor, a displacement current can flow.



Figure 3. 12 Capacitor

An ideal capacitor is characterized by a single constant value for its capacitance. Capacitance is expressed as the ratio of the electric charge (Q) on each conductor to the potential difference (V). The SI unit of capacitance is the farad (F), which is equal to one coulomb per volt (1 C/V). Typical capacitance values range from about 1 pF ( $10^{-12}$  F) to about 1 mF ( $10^{-3}$  F). The capacitance is greater when there is a narrower separation between conductors and when the conductors have a larger surface area. In practice, the dielectric between the plates passes a small amount of leakage current and also has an electric field strength limit, known as the breakdown voltage. The conductors and leads introduce an undesired inductance and resistance. Capacitors are widely used in electronic circuits for blocking direct current while allowing alternating current to pass. In analog filter networks, they smooth the output of power supplies. In resonant circuits they tune radios to particular frequencies. In electric power transmission systems they stabilize voltage and power flow.

### 3.11 Resistor



A resistor is a passive two-terminal electrical component that implements electrical resistance as a circuit element. Resistors act to reduce current flow, and, at the sometime, act to lower voltage levels within circuits. Resistors may have fixed resistances or variable resistances, such as those founding thermostats, visitors, trimmers, photo resistors, hamsters and potentiometers. The current through a resistor is in direct proportion to the voltage across the resistor's terminals. This relationship is represented by Ohm's law



Figure 3. 13 Resistor

### 3.12 Theory of operation

The behavior of an ideal resistor is dictated by the relationship specified by Ohm's law:

$$V = I \times R$$

Ohm's law states that the voltage (V) across a resistor is proportional to the current (I), where the constant of proportionality is the resistance (R).

Equivalently, Ohm's law can be stated:

$$I = \frac{V}{R}$$

This formulation states that the current (I) is proportional to the voltage (V) and inversely proportional to the resistance (R). This is directly used in practical computations. For example, if a  $300\Omega$  resistor is attached across the terminals of a 12 volt battery, then a current of  $12/300 = 0.04$  amperes flows through that resistor.

Table 7.3.1: The Resistor color code

Color	Code	Multiplier	Tolerance
Black	0	$10^0$	--
Brown	1	$10^1$	$\pm 2\%$
Red	2	$10^2$	$\pm 2\%$
Orange	3	$10^3$	--
Yellow	4	$10^4$	--
Green	5	$10^5$	$\pm 0.5\%$
Blue	6	$10^6$	$\pm 0.25\%$
Violet	7	$10^7$	$\pm 0.1\%$
Grey	8	$10^8$	$\pm 0.05\%$
White	9	$10^9$	--
Gold	--	$10^{-1}$	$\pm 5\%$
Silver	--	$10^{-2}$	$\pm 10\%$

### 3.13 LED

#### 3.13.1 Introduction

A light-emitting diode (LED) is a two-lead semiconductor light source. It is a P–N junction diode that emits light when activated. When a suitable current is applied to the leads, electrons are able to recombine with electron holes within the device, releasing energy in the form of photons. This effect is called electroluminescence, and the color of the light is determined by the energy band gap of the semiconductor. LEDs are typically small (less than  $1\text{ mm}^2$ ) and integrated optical components may be used to shape the radiation pattern.

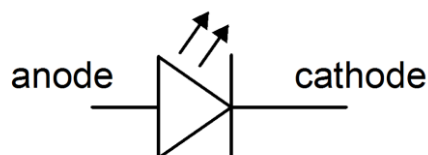

Figure 3. 14Symbol of LED

Appearing as practical electronic components in 1962, the earliest LEDs emitted low-intensity infrared light. Infrared LEDs are still frequently used as transmitting

elements in remote-control circuits, such as those in remote controls for a wide variety of consumer electronics. The first visible-light LEDs were of low intensity and limited to red. Modern LEDs are available across the visible, ultraviolet, and infrared wavelengths, with very high brightness.

### 3.13.2 Overview



Figure 3. 15 LED

Early LEDs were often used as indicator lamps for electronic devices, replacing small incandescent bulbs. They were soon packaged into numeric readouts in the form of seven-segment displays and were commonly seen in digital clocks. Recent developments have produced LEDs suitable for environmental and task lighting. LEDs have led to new displays and sensors, while their high switching rates are useful in advanced communications technology.

LEDs have many advantages over incandescent light sources, including lower energy consumption, longer lifetime, improved physical robustness, smaller size, and faster switching. Light-emitting diodes are used in applications as diverse as aviation lighting, automotive headlamps, advertising, general lighting, traffic signals, camera flashes, lighted wallpaper and medical devices. They are also significantly more energy efficient and, arguably, have fewer environmental concerns linked to their disposal.

Unlike a laser, the color of light emitted from an LED is neither coherent nor monochromatic, but the spectrum is narrow with respect to human vision, and for most purposes the light from a simple diode element can be regarded as functionally monochromatic.

### 3.13.3 Working principle

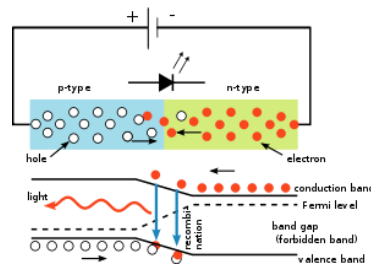

Figure 3. 16Circuit of LED

A P-N junction can convert absorbed light energy into a proportional electric current. The same process is reversed here (i.e. the P-N junction emits light when electrical energy is applied to it). This phenomenon is generally called electroluminescence, which can be defined as the emission of light from a semiconductor under the influence of an electric field. The charge carriers recombine in a forward-biased P-N junction as the electrons cross from the N-region and recombine with the holes existing in the P-region. Free electrons are in the conduction band of energy levels, while holes are in the valence energy band. Thus the energy level of the holes is less than the energy levels of the electrons. Some portion of the energy must be dissipated to recombine the electrons and the holes. This energy is emitted in the form of heat and light.

The electrons dissipate energy in the form of heat for silicon and germanium diodes but in gallium arsenide phosphide (GaAsP) and gallium phosphide (GaP) semiconductors, the electrons dissipate energy by emitting photons. If the semiconductor is translucent, the junction becomes the source of light as it is emitted, thus becoming a light-emitting diode. However, when the junction is reverse biased, the LED produces no light and if the potential is great enough, the device is damaged.

### 3.13.4 Advantages

- Efficiency: LEDs emit more lumens per watt than incandescent light bulbs.
- Color: LEDs can emit light of an intended color without using any color filters as traditional lighting methods need. This is more efficient and can lower initial costs.
- Size: LEDs can be very small (smaller than 2 mm<sup>2</sup>) and are easily attached to printed circuit boards.

- Warm up time: LEDs light up very quickly. LEDs used in communications devices can have even faster response times.
- Cycling: LEDs are ideal for uses subject to frequent on-off cycling.
- Dimming: LEDs can very easily be dimmed either by pulse-width modulation or lowering the forward current. .
- Cool light: In contrast to most light sources, LEDs radiate very little heat in the form of IR that can cause damage to sensitive objects or fabrics.
- Lifetime: LEDs can have a relatively long useful life.
- Shock resistance: LEDs, being solid-state components, are difficult to damage with external shock.
- Focus: The solid package of the LED can be designed to focus its light.

### **3.13.5 Disadvantages**

- Temperature dependence: LED performance largely depends on the ambient temperature of the operating environment.
- Voltage sensitivity: LEDs must be supplied with a voltage above their threshold voltage and a current below their rating.
- Color rendition: Most cool-white LEDs have spectra that differ significantly from a black body radiator like the sun or an incandescent light.
- Efficiency droop: The efficiency of LEDs decreases as the electric current increases.
- Impact on insects: LEDs are much more attractive to insects than sodium-vapor lights, so much so that there has been speculative concern about the possibility of disruption to food webs.

### **3.13.6 Applications**

- Visual signals where light goes more or less directly from the source to the human eye, to convey a message or meaning.
- Illumination where light is reflected from objects to give visual response of these objects.
- Measuring and interacting with processes involving no human vision.

### 3.14 Diode (1N4007)

A diode is an electrical device allowing current to move through it in one direction with far greater ease than in the other. The most common kind of diode in modern circuit design is the semiconductor diode, although other diode technologies exist. Semiconductor diodes are symbolized in schematic diagrams such as Figure below.

The term “diode” is customarily reserved for small signal devices,  $I \leq 1$  A. The term rectifier is used for power devices,  $I > 1$  A.



Figure 3. 17Diode (1N4007)

When placed in a simple battery-lamp circuit, the diode will either allow or prevent current through the lamp, depending on the polarity of the applied voltage.

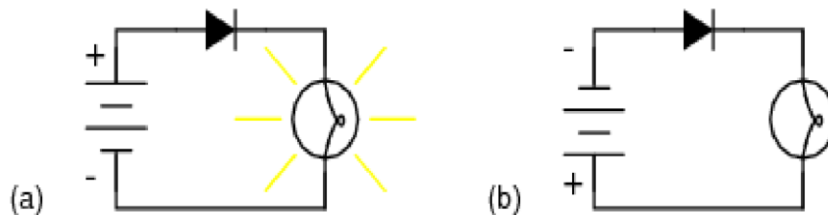

Figure 3. 18 (a) Current flow is permitted; the diode is forward biased. (b) Current flow is prohibited; the diode is reversed biased

When the polarity of the battery is such that electrons are allowed to flow through the diode, the diode is said to be forward-biased. Conversely, when the battery is “backward” and the diode blocks current, the diode is said to be reverse-biased. A diode may be thought of as like a switch: “closed” when forward-biased and “open” when reverse-biased.

### 3.15 Battery

### 3.15.1 Introduction

A lithium-ion battery or Li-ion battery (abbreviated as LIB) is a type of rechargeable battery in which lithium ions move from the negative electrode to the positive electrode during discharge and back when charging. Li-ion batteries use an intercalated lithium compound as one electrode material, compared to the metallic lithium used in a non-rechargeable lithium battery. The electrolyte, which allows for ionic movement, and the two electrodes are the constituent components of a lithium-ion battery cell.

Lithium-ion batteries are common in home electronics. They are one of the most popular types of rechargeable batteries for portable electronics, with a high energy density, tiny memory effect and low self-discharge. LIBs are also growing in popularity for military, battery electric vehicle and aerospace applications.

### 3.15.2 Overview

Chemistry, performance, cost and safety characteristics vary across LIB types. Handheld electronics mostly use LIBs based on lithium cobalt oxide ( $\text{LiCoO}_2$ ), which offers high energy density but presents safety risks, especially when damaged. Lithium iron phosphate ( $\text{LiFePO}_4$ ), lithium ion manganese oxide battery ( $\text{LiMn}_2\text{O}_4$ ,  $\text{Li}_2\text{MnO}_3$ , or LMO), and lithium nickel manganese cobalt oxide ( $\text{LiNiMnCoO}_2$  or NMC) offer lower energy density but longer lives and less likelihood of unfortunate events in real-world use (e.g., fire, explosion, etc.).



Figure 3. 19 Lithium-ion battery

Such batteries are widely used for electric tools, medical equipment, and other roles. NMC in particular is a leading contender for automotive applications. Lithium nickel cobalt aluminum oxide ( $\text{LiNiCoAlO}_2$  or NCA) and lithium titanate ( $\text{Li}_4\text{Ti}_5\text{O}_{12}$  or

LTO) are specialty designs aimed at particular niche roles. The newer lithium sulfur batteries promise the highest performance-to-weight ratio.

Lithium-ion batteries can pose unique safety hazards since they contain a flammable electrolyte and may be kept pressurized. A battery cell charged too quickly could cause a short circuit, leading to explosions and fires. Because of these risks, testing standards are more stringent than those for acid-electrolyte batteries, requiring both a broader range of test conditions and additional battery-specific tests. There have been battery-related recalls by some companies, including the 2016 Samsung Galaxy Note 7 recall for battery fires.

### 3.15.4 Working Principle

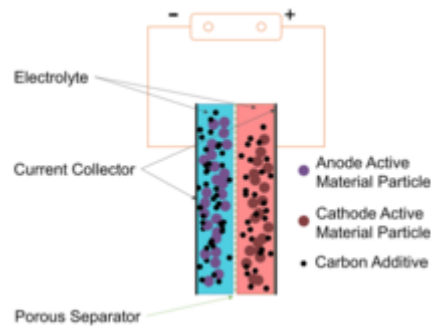

Figure 3. 20 Circuit of lithium battery

The reactants in the electrochemical reactions in a lithium-ion battery are the negative and positive electrodes and the electrolyte providing a conductive medium for lithium ions to move between the electrodes. Electrical energy flows out from or in to the battery when electrons flow through an external circuit during discharge or charge, respectively.

During discharge, the lithium ions move from the negative electrode to the positive electrode (cathode) through the electrolyte while the electrons flow through the external circuit in the same direction. When the cell is charging, the reverse occurs with the lithium ions and electrons move back into the negative electrode in a net higher energy state. The following equations exemplify the chemistry.



# Chapter- 4

## Result and Discussion

### 4.1 Introduction

When compared with olden days life span of human is reduced. Death rate due to accident is drastically increased because vehicles usage is increasing by day by day. Due to brake failure so many accidents are occurring so when we control the brake by automatically we can reduce the effect of accident. A Ultrasonic setup is placed in front of vehicle and that setup consists of an emitter and a receiver. Ultrasonic emitter always emits the ultrasonic waves, whenever a obstacle is detected then wave gets reflected and receiver receives the signal. Reflected wave sends the signal to the Arduino Nano from that based upon distance of object it actuates the buzzer or brakes. Brakes are actuated by using Solenoid valve. Solenoid valve operated by electrical signal and it actuates brakes by using pneumatics. UBS car provides the glimpse into the future of automotive safety. By UBS system we can prevent more accidents and save more lives.

The cooling system is a key to efficient engine operation. An internal combustion engine only uses one-third of the power produced. One-third heats oil or goes out the exhaust and one-third must be controlled by the water cooling system. 1. An engine wears out four times faster if it continually operates at a low temperature. 2. A tractor doing the same work will use 3.8 gallons of fuel per hour at 400 and only 2.8 gallons of fuel per hour at 1800. Warm up your engine before putting under load. 3. Too much heat can damage an engine, increase oxidation to the oil, and reduce the effectiveness of the additives in the oil. 4. Excessive heat may attack seals, liners, gaskets, and sealants. 5. A thin (1/16") layer of calcium carbonate build-up on an engine is equal to 4" of solid cast iron in heat transfer.

## 4.2 Results:

The system holds well in situations where the conditions aid in better performance of the functional units, especially the sensors. Such favorable situations in which operations can be carried out decisively can never be certain as functioning provides issues conflicting to theoretical assumptions. The system has been tested based on its response during the specified ranges of operation following the feedback from sensors that have been placed to detect any obstacle that may be caused a possible collision.

Here, the time mentioned is the time taken by the sensors to receive the transmitted signal after being reflected from an obstacle. Distance from the obstacle is calculated using the formula:-

$$\text{Distance} = \frac{\text{time} * (343 * 100 * 10^{-6})}{2}$$

Where;

Distance is in centimeters and time is in microseconds

The results have been tabulated as follows-

Sl.NO	Range's	Sensor's
1	$\leq 1,000 \text{ cm}$	Front object detect activated
2	$< 20 \text{ cm}$	Braking
3	$> 35^{\circ}\text{C} / 95^{\circ}\text{F}$	Pump water circulation activated
4	$> 35^{\circ}\text{C} / 95^{\circ}\text{F}$	Cooling fan activation

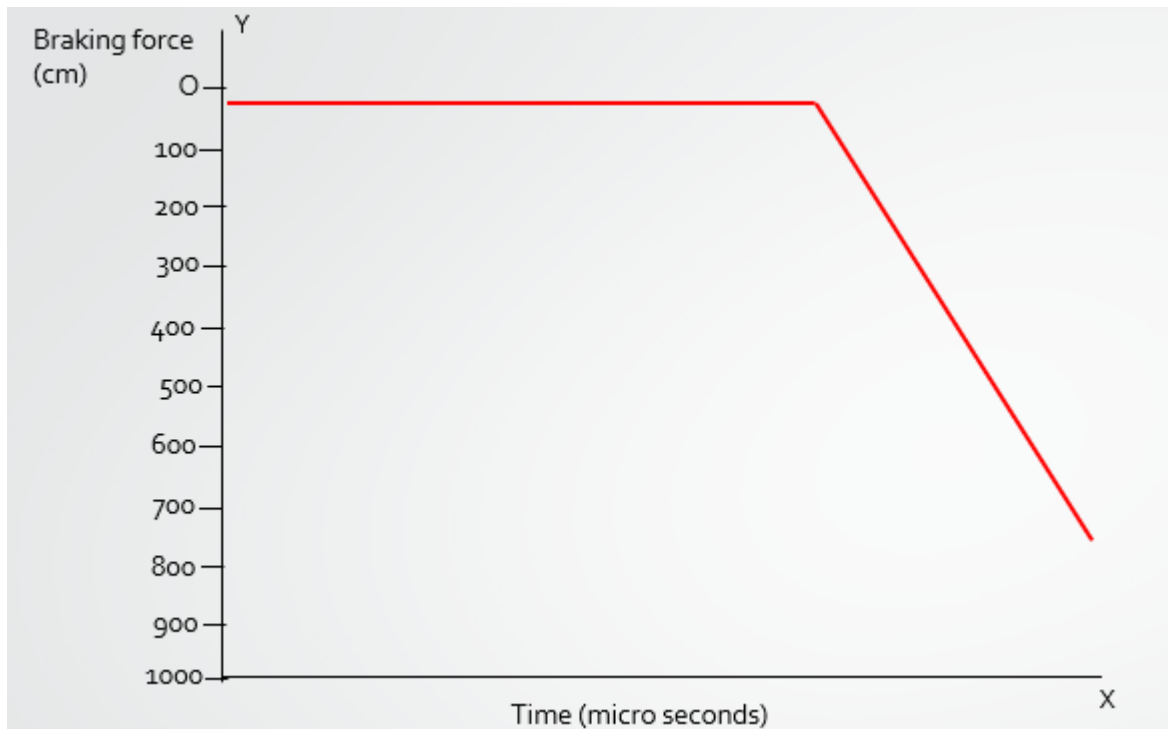

In this graph, the x-axis represents time in micro-seconds and the y-axis represents the percentage of braking force applied by the automatic braking system. The graph shows the gradual increase in braking force over time as the system engages to prevent a collision.

The graph starts with a baseline of 1000 cm of object indication with no braking system activation. As the system detects a potential collision reaching the limiter settled to 20 cm range, the braking force is applied.

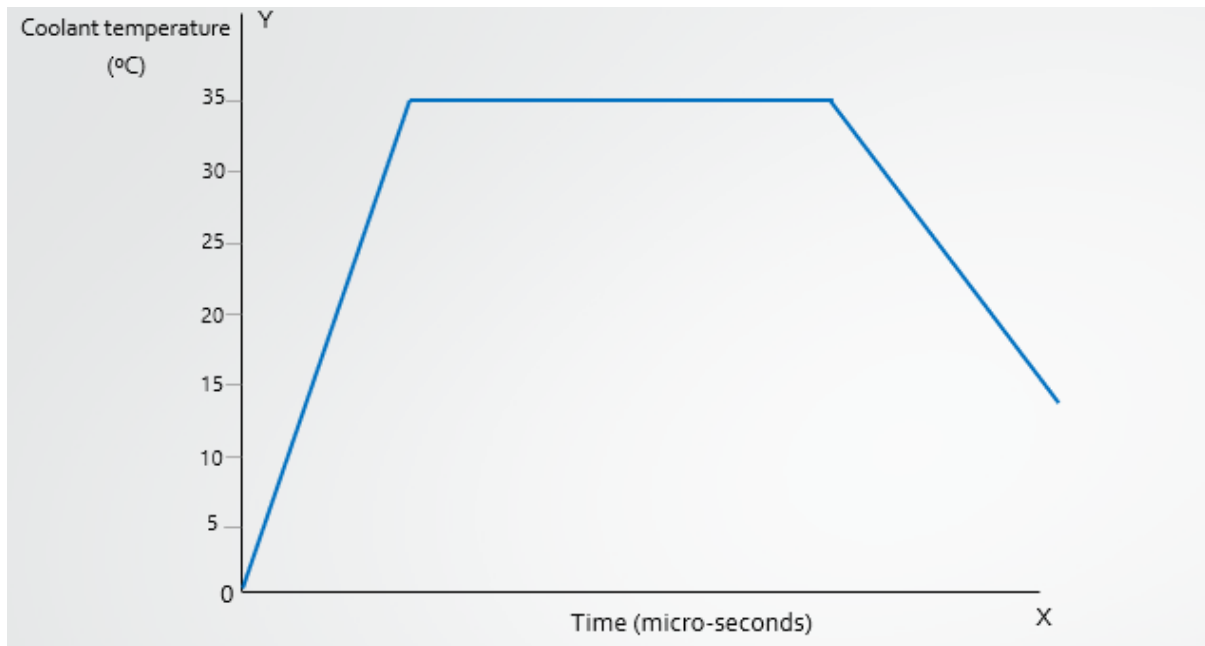

In this graph, the x-axis represents time in micro-seconds and the y-axis represents the temperature of the engine in degrees Celsius. The graph shows the fluctuations of the coolant temperature over time as the engine operates and the cooling system works to maintain a stable temperature.

The graph starts with an initial coolant temperature, which may vary depending on the engine's operating conditions. As the engine runs, the coolant temperature may rise due to heat generated by the combustion process and if it reaches the required temperature of 36 degree Celsius. The coolant system then engages, dissipating the excess heat and bringing the temperature back down. The graph showcases the cyclic nature of the coolant temperature as it fluctuates during the engine's operation.

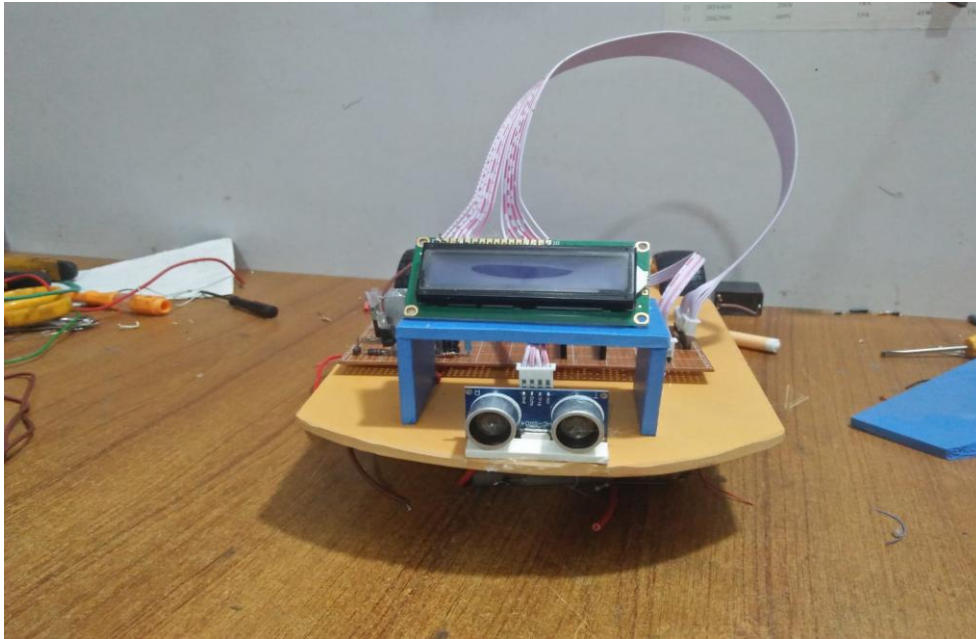

Figure 4. 1 Overview of our project

### 4.3 Advantages

- Drum distortion is reduced significantly in electromagnetic disk brake systems.
- Potential hazard of tire deterioration and bursts due to friction is eliminated.
- There is no need to change brake oils regularly.
- There is no oil leakage.
- The practical location of the retarder within the vehicle prevents the direct impingement of air on the retarder caused by the motion of the vehicle.

### 4.4 Disadvantages

- Dependence on battery power to energize the brake system drains down the battery much faster.
- Due to residual magnetism present in electromagnets, the brake shoe takes time to come back to its original position.

# Chapter-5

## CONCLUSION

### 5.1 Conclusion

The Ultrasonic Braking System, if executed in auto it deflects heaps of mishaps and can spare human lives and property. Execution of such a propelled framework can be made mandatory like wearing of safety belts with the goal that mischance's can be deflected to some degree. Our Infrared Braking System gives a look into the eventual fate of car wellbeing and the amount more propelled this individual framework can be for staying away from mischances and ensuring vehicle tenants when they are incorporated into one framework. The fate of car security is more than simply building up another innovation; it is moving the way to deal with wellbeing. Ultrasonic Braking System approach speaks to a huge movement from the conventional way to deal with wellbeing, yet it is crucial to accomplishing the significant advantages.

Cooling system is one of the important parts of the automobile; it dissipates the extra heat out of the engine which can damage the various components of the engine. The temperature of the engine reaches high enough to weld the piston with the cylinder which can damages the engine. So there is a provision of cooling system which keeps the various components of the engine cool and safe. In this project we used water cooling system with temperature sensor indication .

## C- CODE FOR THIS PROJECT

```
#include<LiquidCrystal.h>
```

```
LiquidCrystallcd(12,11,10,9,8,7);
```

```
#include <Servo.h>
```

```
#define leftMotor1 2
```

```
#define leftMotor2 3
```

```
#define rightMotor1 4
```

```
#define rightMotor2 5
```

```
void LCDshow();
```

```
void Forward();
```

```
void Backward();
```

```
void leftTurn();
```

```
void rightTurn();
```

```
void StopBot();
```

```
void settings();
```

```
void LOADCTRL();
```

```
const int echoPin = A4;
```

```
const int trigPin = A5;
```

```
long duration;
```

```
int distance;
```

```
const int buttonPin1 = A2;
```

```
const int buttonPin2 = A3;
```

```
int buttonState1 = 0;
```

```
int buttonState2 = 0;
```

```
short MODE=0;
```

```
char str[15];
```

```
int CNT,CNT2=3,SECNT,SEC,MIN,SECs=5,MINs=0,STRT,SETCNT=0,POS=0,i;
```

```
void setup()
```

```
{
```

```
  lcd.begin(16,2);
```

```
  lcd.setCursor(0,0);
```

```
  lcd.print(" AUTO BREAKING ");
```

```
  lcd.setCursor(0,1);
```

```
  lcd.print("  SYSTEM  ");
```

```
  pinMode(buttonPin1, INPUT);
```

```
  pinMode(buttonPin2, INPUT);
```

```
  pinMode(trigPin, OUTPUT);
```

```
  pinMode(echoPin, INPUT);
```



```

pinMode(rightMotor1, OUTPUT);

pinMode(rightMotor2, OUTPUT);

pinMode(leftMotor1, OUTPUT);

pinMode(leftMotor2, OUTPUT);

}

////////////////////////////////////////////////////////////////

void loop()

{

LOADCTRL();

    buttonState1 = digitalRead(buttonPin1);

    if (buttonState1 == HIGH)

settings();

    //////////////////////////////////////////////////////////////////

    CNT++;

if(CNT > 200)

    {

USSsensor();

LCDshow();

    CNT=0;

    }

////////////////////////////////////////////////////////////////

```

```
}  
  
////////////////////////////////////
```

```
void LOADCTRL()
```

```
{
```

```
if(MODE==0)
```

```
{
```

```
Forward();
```

```
USSsensor();
```

```
    if (distance < 20)
```

```
    {
```

```
StopBot();delay(200); POS++;delay(200);
```

```
    //////////////////////////////////////
```

```
leftTurn();
```

```
Forward();
```

```
leftTurn();
```

```
}
```

## REFERENCES:-

1. Hemalatha B. K., Pooja, Chaithra M., Megha S., Rakshitha R. T. “Automatic Braking System for Automobiles Using IR Sensor” International Journal of Advanced Research in Electrical, Electronics and Instrumentation Engineering Vol. 5, Issue 5, May 2016.
2. Gopal P. Gawande, Shruti V.Gavhale, Irshad A. Zariye, Sagar P. Ritpurkar “Review of speed control and automatic braking system” International Journal of Engineering Research & Technology (IJERT) Vol. 3 Issue 2, February – 2014.
3. Divya Thakur Prof. A. P. Thakare “Implementation of automatic reverse braking system on fpga” IETE 46th Mid Term Symposium ‘Impact of Technology on Skill Development Mts-2015, Special Issue Of Inter National Journal Of Electronics, Communication & Soft Computer Science & Engineering.
4. Dhanya K. R. R. Jeyanthi “Automatic braking system with sensor fusion concept” IEES 4(1) June 2012
5. Density of Liquid Water. [Online], [www.vaxasoftware.com](http://www.vaxasoftware.com) [10]Karim Nice, “How Car Cooling Systems Work”. [Online] <https://auto.howstuffworks.com/cooling-system.htm>
6. Anusha. Dr. P. Venkataratnam “Collision control and collision avoidance using ultrasonic sensor” International Journal Of Current Engineering And Scientific Research (Ijcesr), ISSN (PRINT): 2393-8374, (ONLINE): 2394-0697, VOLUME-2, ISSUE-7, 2015
7. Ravi Ingle, Sumit Thak, Ankush Shelke. “Automated reverse braking system” International Journal Of Engineering Sciences & Research Technology,3(4): April, 2014 ISSN: 2277-9665
8. Katore S.R., Kadlag S.C., Mane P.V., Pawar G.V., Prof.Londhe B.C. “Automatic braking with pneumatic bumper system” A R Digitech International Journal Of Engineering, Education And Technology (Ardijeet, Issn 2320-883x, Volume 3, Issue 2, 01/04/2015. 8. Mr. Shinde Abhijeet Balasaheb Mr. Panase Prathmesh Shantaram Mr. Chemate Pravin Dadabhau Mr. Pawar Sandip Raghunath Prof-Dhage S.K “Automatic pneumatic bumper-braking system” IJSRD - International Journal for Scientific Research & Development, Vol. 4, Issue

01, 2016 | ISSN (online): 2321-0613 740-741, August 1987 [Digests 9th Annual Conf. Magnetism Japan, p.301, 1982]

9. <http://content.answcdn.com/main/content/img/McGrawHil1/Aviation>

10. [www.google.co.in](http://www.google.co.in)

11. Pulford, Graha W. (2007). An encyclopedic reference. ISBN 0750684372

12. Internal Combustion Engines by H.N. Gupta

13. Engine Cooling Systems HP1425 by [Ray T. Bohacz](#)

14. Automotive Cooling System Basics by [Randy Rundle](#)