

DESIGN AND FABRICATION OF AN AUTOMATED DOUBLE HACKSAW MACHINE

A thesis
by

FOYSAL AHAMED

ID: BME2001020197

RAJIB CHANDRA ADHIKARI

ID: BME2001020147

MD. MILON HOSSAIN

ID: BME2001020146

Supervised by

Nuruzzaman Rakib
Assistant Professor
Department of Mechanical Engineering
Sonargaon university (SU)



Department of Mechanical Engineering
SONARGAON UNIVERSITY (SU)
Dhaka, Bangladesh
SEPTEMBER 2023

ACKNOWLEDGEMENT

First, we started in the name of almighty Allah. Then thank you to our parents for always taking care of us and supporting us. This thesis is accomplished under the Supervision of Assistant Professor Nuruzzaman Rakib, department of Mechanical Engineering, Sonargaon University. It is a great pleasure to acknowledgement our profound gratitude and respect to our supervisor for this consistent guidance, encouragement, helpful suggestion, constructive criticism endless patience through the progress of this work. The successful completion of this thesis would not have been possible without his persistent motivation continuous guidance.

The authors are also grateful to Md Mostofa Hossain, Professor, Head of the Department of Mechanical Engineering and all respect teachers of the Mechanical Engineering Department for their co-operation and significant help for completing the thesis work successfully.

ABSTRACT

A hacksaw is a fine-toothed saw, originally and mainly made for cutting metal, plastic or wood. For industries to realize the production, it is necessary to cut metal, plastic bars with high rate. So, it's not possible to depend on typical single frame power saw machines and wish the advance in technology and style of such machines.

To automate the conventional power hacksaw machine in order to achieve high productivity of workpieces, we have proposed a power hacksaw machine that uses pneumatic power. The high-speed saw machine contains a bonus of high operation, the saw utilized in this can be used for specified needs and can be used to cut consistent with the necessity.

The pneumatic operated double hacksaw is the plastic cutting machine tool designed to cut plastic by applying pneumatic pressure. Hacksaws are used to cut thin and soft metals, plastic. This pneumatic double hacksaw machine consists of rods for guiding hacksaw, Crank, stand base frame. The guide plate pushes the second link. Pneumatic cylinder and other linkage are arranged so that it will actuate two hacksaw blades. Pneumatic operated double hacksaw machines can be used for cutting the wood, metal, pipe, angle, channel, flat plates, rods, and such other things.

TABLE OF CONTENTS

	Page No.
Acknowledgement	1
Abstract	2
Table of Contents	3
Micro controller simulation	5

CHAPTER 1

1.1 Introduction -----	6
1.2 Objectives -----	7
1.3 Summary -----	7

CHAPTER 2

2.1 Building up system -----	8
2.2 Block diagram -----	8
3.1 Arduino nano -----	9
2.3 Circuit diagram -----	10
2.4 Working principle -----	10
2.5 Prototype output -----	10

CHAPTER 3

3.1 Arduino nano -----	11
3.1.1 Features -----	12
3.1.2 Specifications -----	12
3.1.3 3Microcontroller IC Atmega328p -----	12
3.2 Air compressor -----	12
3.2.1 Features -----	13
3.2.2 Specifications -----	13
3.2.3 Air cylinder -----	13
3.3 Specifications -----	14
3.4 Solenoid valve -----	14
3.5 Relay -----	15

CHAPTER 4

4.1 Arduino software -----	17
4.2 Proteus software -----	18
4.3 Micro controller simulation -----	19
4.4 PCB design -----	19
4.5 3D verification -----	20

CHAPTER 5

5.1 Properties Result ----- 21

CHAPTER 6

6.1 Discussion ----- 22
6.2 Advantages ----- 22
6.3 Applications ----- 22
6.4 Future Scope ----- 22

REFERENCES 23

APPENDIX 24

LIST OF TABLES AND FIGURES

Figure number	Figure name	Page
Fig 2.1	System of our project	8
Fig 2.2	Block Diagram of Project	9
Fig 2.3	Circuit Diagram of Project	9
Fig 2.4	Our complete project	10
Fig 3.1	Arduino Nano	11
Fig 3.2	300 PSI 12 V Portable Mini Air Compressor	13
Fig 3.3	Air Cylinder	14
Fig 3.4	Solenoid Valve	15
Fig 3.5	Relay	15
Fig 4.1	Arduino Software Interface IDE	17
Fig 4.2	PCB design	18
Fig .3	3D verification	19
Fig 4.4		20

CHAPTER 1

INTRODUCTION

1.1 Introduction

There are many electrically operated power hack saw machines of different configuration and different manufacturers are available for the use in a machine shop. These machines can cut rods of different materials precisely at a very fast rate but they can cut rods of one material at a time which means they can't able to cut dissimilar material at the same time. Now in industry, it is necessary to cut metal bars at a very high rate to achieve mass production requirements. So there is a need to move for a new technology which gives us a mass production with less time and less energy input. [1]. It is impossible to depend upon conventional hack saw machine. By using this two-way hack saw machine the two metal bars, pipes or rods can be cut simultaneously to achieve high-speed cutting rate and mass production for maximum benefits in manufacturing industries. This machine overcomes the drawbacks and limitations of a single frame hack saw machine. It can be used in small workshops and industries as it is available at a very low price and its smaller size and high efficiency. This paper focus on presents the manufacture and idea of a two-way hacksaw removing machine predominantly conveyed for creation based ventures. Businesses are fundamentally implied for the creation of valuable merchandise and ventures at low generation cost, Machinery cost, and low stock cost. [2] Today in this world each errand has been made snappier and quick because of innovation progression yet this headway likewise requests colossal speculation and consumption, each industry wants to make a high-efficiency rate keeping up the quality and standard of the item at low normal cost. We have developed a prototype model, which is efficient and does multiple cutting operations. These machines can be utilized as a part of remote spots where power is customary. It is composed as a convenient one which can be utilized for cutting in different spots. It can be utilized for working on materials like thin metals, wood.[3]A hacksaw is a handheld device used to slice through materials like plastic tubing and metal funnels. Its cutting system is given by removable edges which include sharp teeth along their external edge. As a rule, a hacksaw comprises of a metal casing that takes after a descending confronting. A handle of plastic, wood, or metal is regularly joined to one end of the casing.[4] The edge's closures highlight customizable pegs that can be fixed to anchor a sharp edge set up and extricated to expel it.

Hacksaw sharp edges are long, thin portions of solidified steel that element a line of teeth along their front line. Each finish of the edge is punched with a little gap that fits onto the saw edge's pegs. Most sharp edges extend long from ten to 12inches (25.4 to 30.48 cm), albeit six-inch (15.24 cm) edges can be acquired to fit littler hacksaw models.[5] A gadget that applies compel, alters the course of power, or changes the quality of power, with a specific end goal to play out an errand, by and large including work done on a heap. Machines are regularly intended to yield a high mechanical preferred standpoint to decrease the exertion expected to do that work. A straightforward machine a wheel, a lever or a slanted plane. Every single other machine can be constructed utilizing mixes of these straightforward machines. Illustration: A penetrates utilizes a blend of riggings (wheels) to drive helical slanted planes (the bore) to part material and cut an opening in it.[6]

1.2 Objectives

The main objectives of this project are-

- To study a pneumatic system
- To design & construct an automatic double hacksaw system.
- To implement the double hacksaw system.

1.3 summary:

The "Design and Fabrication of an Automated Double Hacksaw Machine" is an engineering project that aims to revolutionize industrial metal cutting processes. This machine, equipped with two hacksaw blades, automates the cutting operation, increasing efficiency and precision. Its key features include precise and consistent cuts, safety mechanisms, and user-friendly controls. This innovation not only enhances productivity but also minimizes manual labor and operational costs. The machine's versatility enables it to handle various metal materials and sizes, making it suitable for a wide range of industrial applications. In summary, this project represents a significant advancement in the field of metal cutting technology, offering industries a cost-effective, efficient, and safe solution for their cutting needs.

CHAPTER 2

DESIGN AND BUILDING

2.1 Building up the System

Pneumatic is the branch of technology, which uses air as the primary medium for various cutting operations. Pneumatics is the medium that is used for obtaining smooth surface finish and it is economical so that it can be used for the lightweight operation. There are not any adverse impacts in using the pneumatic system, as the system used here is an open-loop system [7]. Pneumatic pressure is supplied through the compressed tank to the cylinder where the hacksaw is attached to another end, compressed air provides the necessary mechanical motion inside the pneumatic cylinder to perform the to and fro motion for cutting operation. There is no vibration and shock in this system because of the usage of compressed air [8]. Controlling this machine is as easy as it is a simple ON-OFF type. The design is particularly suited to applications where the working space is constrained, Pneumatic hacksaws are useful when materials need to be cut in hazardous areas such as oil & gas refineries, chemical factories or oil rigs as well as dusty and wet environments where electric tools are not effective.[9]

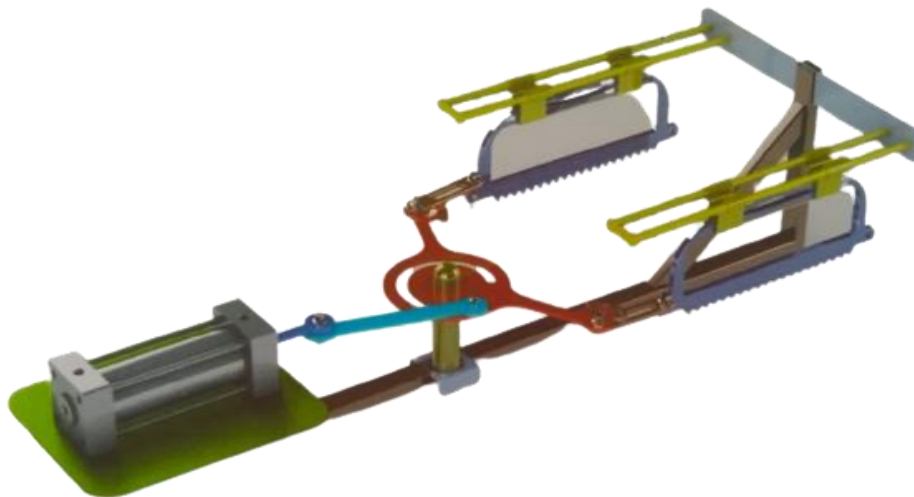

Figure 2.1: System of our project [1]

2.2 Block Diagram

We used the SMPS DC power supply to power up our whole system. We used an air compressor which controlled the cylinder. In this project, we have used Arduino nano for diagram. automatic controlled & switching the solenoid valve. Below showing our full project block diagram.

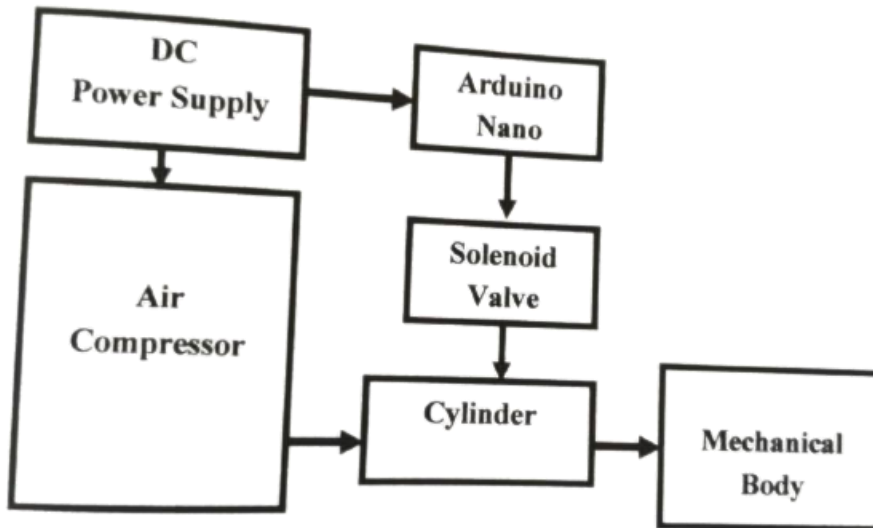

Figure 2.2: Block Diagram of Project

2.3: Circuit Diagram

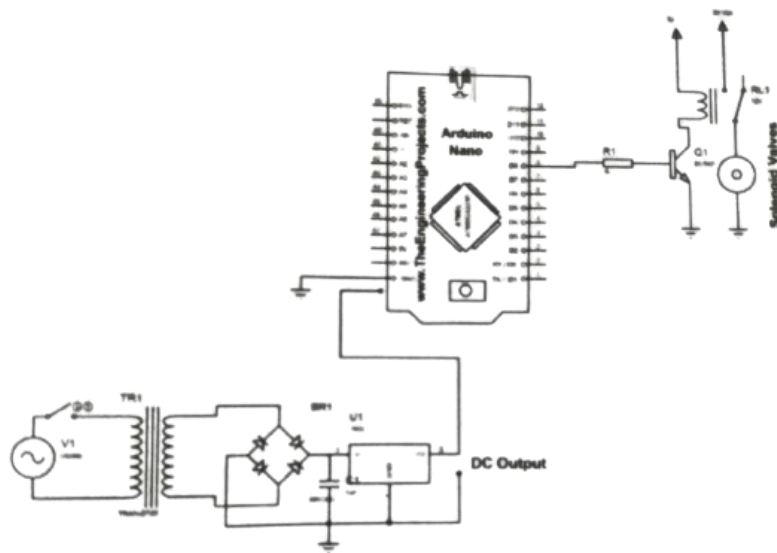

Figure 2.3: Circuit Diagram of Project [2]

2.4 Working Principle

In this project, we used the Arduino family board Arduino Nano as the main controller of our project. we used an air compressor for controlled the mechanical body. After the power-up of the project the system ready to work. When the compressor is ON compressor produce air continuously. This air goes into a cylinder & out this air. this cylinder connected with a fully mechanical body. The air entry and exit of the cylinder totally controlled by Arduino. A relay is used for automatic switching of the solenoid valves.

2.5 Prototype Output



Fig 2.4: our complete project

CHAPTER 3

EQUIPMENTS & COMPONENTS

3.1 Arduino Nano:

Arduino is an open-source electronics prototyping platform based on flexible, easy-to-use hardware and software. It's intended for artists, designers, hobbyists, and anyone interested in creating interactive objects or environments. Arduino can sense the environment by receiving input from a variety of sensors and can affect its surroundings by controlling lights, motors, and other actuators.

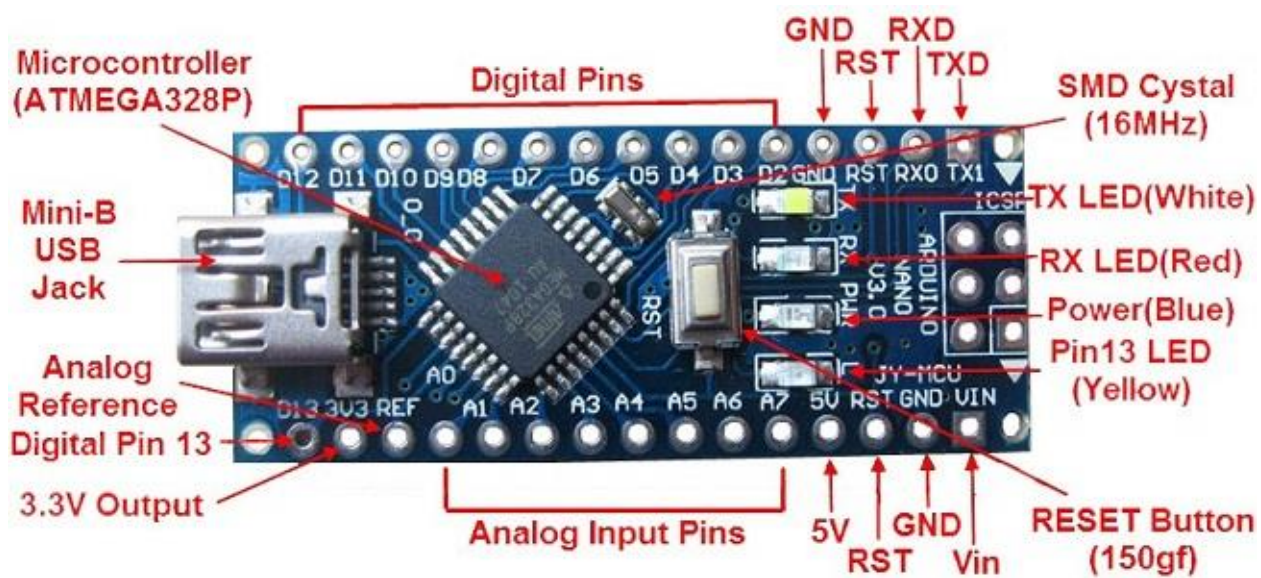

Figure 3.1: Arduino Nano

The microcontroller on the board is programmed using the Arduino programming language (based on Wiring) and the Arduino development environment (based on Processing). Arduino projects can be stand-alone or they can communicate with software on running on a computer (e.g. Flash, Processing, MaxMSP). [5]

Arduino Nano is a surface mount breadboard embedded version with integrated USB. It is small, complete, and breadboard-friendly. It has everything that Diecimila/ Duemilanove has (electrically) with more analog input pins and onboard +5V AREF jumper. Physically, it is missing power jack. The Nano automatically senses and switches to the higher potential source of power.

Nano's got the breadboard ability of the Boarduino and the Mini+ USB with a smaller footprint than either, so users have more breadboard space. It's got a pin layout that works well with the Mini or the Basic Stamp (TX, RX, ATN, GND on one top, power and ground on the other).[6] This new version 3.0 comes with ATMEGA328 which offers more programming and data memory space. It is two layers. That makes it easier to hack and more affordable.[8]

3.1.1 Specifications

Microcontroller: Atmel ATmega328
Operating Voltage (logic level):5 V
Input Voltage (recommended):7-12 V
Input Voltage (limits):6-20 V
Digital I/O Pins: 14 (of which 6 provide PWM output)
Analog Input Pins: 8
DC Current per I/O Pin: 40 mA
Flash Memory: 32 KB (of which 2KB used by the boot loader)
SRAM: 2 KB
EEPROM: 1 KB
Clock Speed: 16 MHz
Dimensions: 0.70" x 1.70"

3.1.2 Features

- Automatic reset during program download
- Power OK blue LED
- Green (TX), red (RX) and orange (L) LED
- Auto-sensing/switching power input
- Small mini-B USB for programming and serial monitor
- ICSP header for direct program download
- Standard 0.1 spacing DIP (breadboard friendly)
- Manual reset switch

19

RESET Button (150g)

3.1.3 Microcontroller IC ATmega328P:

The high-performance Microchip picoPower 8-bit AVR RISC-based microcontroller combines 32KB ISP flash memory with read-while-write capabilities, 1024B EEPROM, 2KB SRAM, 23 general-purpose I/O lines, 32 general purpose working registers, three flexible timer/counters with compare modes, internal and external interrupts, serial programmable USART, a byte-oriented 2-wire serial interface, SPI serial port, a 6-channel 10-bit A/D converter (8-channels in TQFP and QFN/MLF packages), programmable watchdog timer with internal oscillator, and five software selectable power saving modes. The device operates between 1.8-5.5 volts. By executing powerful instructions in a single clock cycle, the device achieves throughputs approaching 1 MIPS per MHz balancing power consumption and processing speed.[6]

3.2 Air Compressor

An air compressor is a device that converts power (using an electric motor, diesel or gasoline engine, etc.) into potential energy stored in pressurized air (i.e., compressed air). By one of several methods, an air compressor forces more and more air into a storage tank, increasing the pressure. When tank pressure reaches its engineered upper limit, the air compressor shuts off. The compressed air, then, is held in the tank until called into use.[1] The energy contained in the compressed air can be used for a variety of applications, utilizing the kinetic energy of the air as it is released and the tank depressurizes.] When tank pressure reaches its lower limit, the air compressor turns on again and re-pressurizes the

tank. An air compressor must be differentiated from a pump because it works for any gas/air, while pumps work on a liquid.[8]



Figure 3.2: 300 PSI 12 V Portable Mini Air Compressor

3.2.1 Features

- It is good for the emergency needs when you are on the highway and countryside road or rushes for office in the morning while the tire low pressure.
- Easy to use - just plug into your car cigarette lighter for power; slip universal adapter over tire valve and you're ready to inflate.
- Light-weight & Compact Design, convenience to put it in the trunk of a car and not occupy any space.
- Powered by your 12V car cigarette lighter.
- Equipped with pressure checking gauge.
- 3 Nozzle adapters for inflating tires, sports and etc.
- Suitable for cars, bicycles, motorcycles, kayaks, ball and other fast inflatables (not suitable for trucks, SUVs)

3.2.2 Specifications

Material: ABS (Acrylonitrile Butadiene Styrene)
Color: Black
Voltage: DC 12V
Current: 10A
Air Pressure: 300 PSI
Airflow: 25L/min.
Cable length: 2M/78.74"
Dimensions: 12.5x6.5x11.5cm/4.92x2.56x4.53"

3.3 Air Cylinder

Pneumatic cylinder(s) (sometimes known as air cylinders) are mechanical devices that use the power of compressed gas to produce a force in a reciprocating linear motion. Like hydraulic cylinders, something forces a piston to move in the desired direction. The piston is a disc or cylinder, and the piston rod transfers the force it develops to the object to be moved.[1] :85 Engineers sometimes prefer to use pneumatics because they are quieter, cleaner, and do not require large amounts of space for fluid

storage. Because the operating fluid is a gas, leakage from a pneumatic cylinder will not drip out and contaminate the surroundings, making pneumatics more desirable where cleanliness is a requirement.[7]



Figure 3.3: Air Cylinder

3.3.1 Specification

Product name- Air Cylinder
Model- MAL25x50
Action Type- Double Action
Material- Aluminum Alloy
Bore- 25mm
Stroke- 50mm
Max Pressure- IMPA
End Cap Thread-M22x1.5
Rod Thread- M10x1.25
Diameter- Air Hole Diameter PT1/8

3.4 Solenoid Valve

A solenoid valve is an electromechanically operated valve. Solenoid valves differ in the characteristics of the electric current they use, the strength of the magnetic field they generate, the mechanism they use to regulate the fluid, and the type and characteristics of fluid they control. The mechanism varies from linear action, plunger-type actuators to pivoted-armature actuators and rocker actuators. The valve can use a two-port design to regulate flow or use a three or more port design to switch flows between ports. Multiple solenoid valves can be placed together on a manifold. Solenoid valves are the most frequently used control elements in fluidics.[6] Their tasks are to shut off, release, dose, distribute or mix fluids. They are found in many application areas. Solenoids offer fast and safe switching, high reliability, long service life, good medium compatibility of the materials used, low control power and compact design.



Figure 3.4: Solenoid Valve

There are many valve design variations. Ordinary valves can have many ports and fluid paths. A 2-way valve, for example, has 2 ports; if the valve is open, then the two ports are connected and fluid may flow between the ports; if the valve is closed, then ports are isolated. If the valve is open when the solenoid is not energized, then the valve is termed normally open (N.O.).[3] Similarly, if the valve is closed when the solenoid is not energized, then the valve is termed normally closed. There are also 3-way and more complicated designs. A 3- way valve has 3 ports; it connects one port to either of the two other ports (typically a supply port and an exhaust port).[2]

3.5 Relay

A relay is an electrically operated switch. It consists of a set of input terminals for a single or multiple control signals, and a set of operating contact terminals. The switch may have any number of contacts in multiple contact forms, such as making contacts, break contacts or combinations thereof.[6]

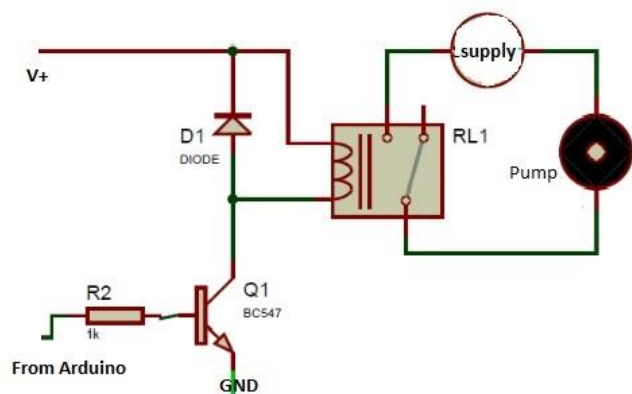
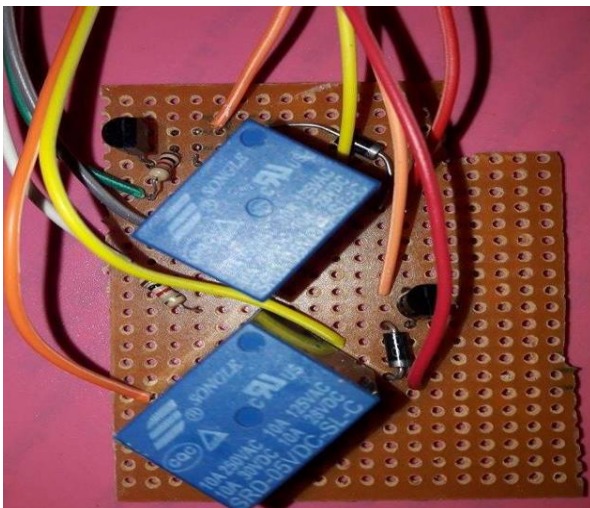

Fig 3.5: Relay

An electrical relay is an electromagnetically operated electrical switch - an electromechanical switch. A relatively small current is used to create a magnetic field in a coil within a magnetic core and this is used to operate a switch that can control a much larger current. In this way, an electromechanical relay or electrical relay can use a small current to switch a much larger current and enable both circuits to be electrically isolated from each other. Electrical relays. come in a variety of different sizes and they can be of a variety of different types using slightly different technologies, although they all use the same basic concept.[5]

CHAPTER 4

SOFTWARES USED

4.1 Arduino Software

The smart microcontroller unit named as Arduino Uno can be programmed with the Arduino software. There is no requirement for installing other software rather than Arduino. Firstly, Select "Arduino Uno from the Tools, Board menu (according to the microcontroller on your board). The IC used named ATmega328 on the Arduino Uno comes pre burned with a boot loader that allows you to upload new code to it without the use of an external hardware programmer.[4]

Download the Arduino IDE

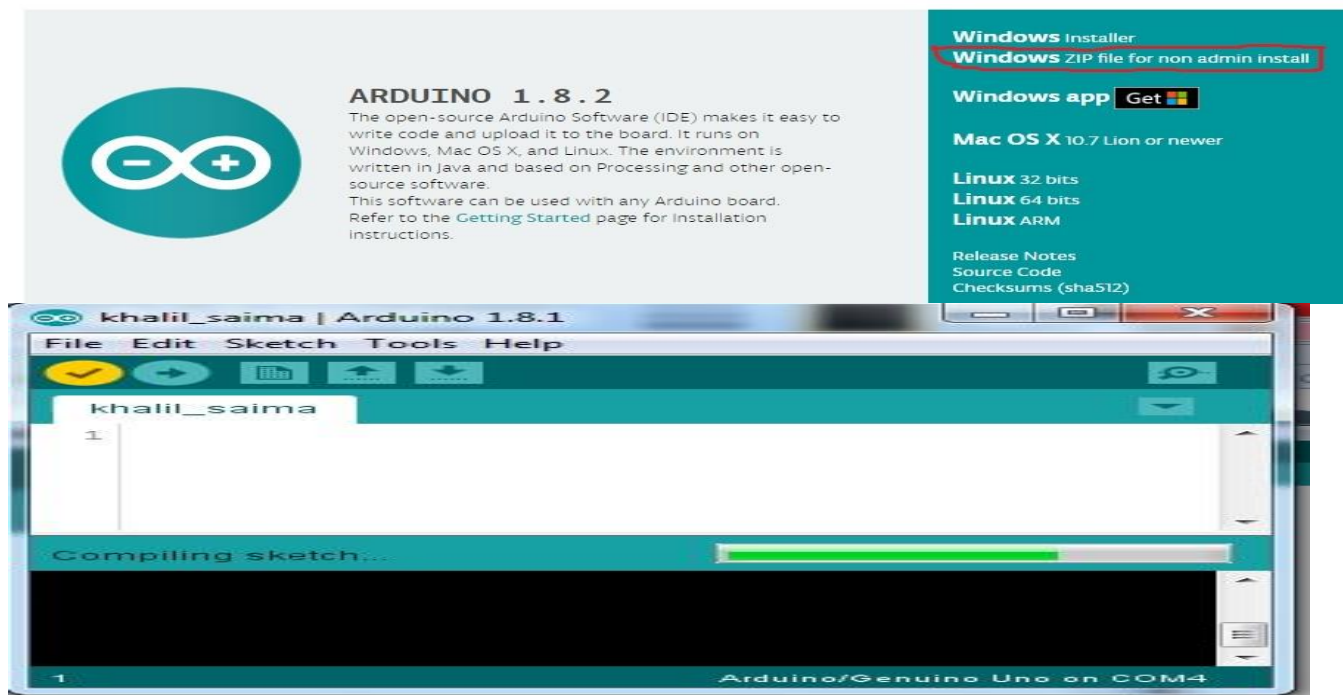

Figure 4.1: Arduino Software Interface IDE

Communication is using the original STK500 protocol (reference, C header files). We can also bypass the boot loader and programs the microcontroller through the ICSP (In-Circuit Serial Programming) header. The ATmega16U2 (or 8U2 in the rev1 and rev2 boards) firmware source code is available. The ATmega16U2/8U2 is loaded with a DFU boot loader, which can be activated by: [5]

On Rev1 boards: connecting the solder jumper on the back of the board (near the map of Italy) and then resetting the 8U2. On Rev2 or later boards: there is a resistor that pulling the 8U2/16U2 HWB line to ground, making it easier to put into DFU mode.

The Arduino Uno is one of the latest smart microcontroller units and has a number of facilities for communicating with a computer, another Arduino, or other microcontrollers. The ATmega328 provides UART TTL at (5V) with serial communication, which is available on digital pins 0 (RX) to receive the data and pin no.1 (TX) to transmit the data. An ATmega16U2 on the board channels this serial

communication over USB and appears as a virtual com port to software on the computer. The '16U2 firmware uses the standard USB COM drivers, and no external driver is needed. However, on Windows, a .inf file is required. The Arduino software includes a serial monitor which allows simple textual data to be sent to and from the Arduino board. [3]

The RX and TX LEDs on the board will flash when data is being transmitted via the USB-to-serial chip and USB connection to the computer (but not for serial communication on pins 0 and 1). A Software Serial library allows for serial communication on any of the Uno's digital pins. The ATmega328 also supports I2C (TWI) and SPI communication. The Arduino software includes a Wire library to simplify the use of the 12C bus. Arduino programs are written in C or C++ and the program code written for Arduino is called a sketch. The Arduino IDE uses the GNU toolchain and AVR Lab to compile programs, and for uploading the programs it uses avrdude. As the Arduino platform uses Atmel microcontrollers, Atmel's development environment, AVR Studio or the newer Atmel Studio, may also be used to develop software for the Arduino. [4]

4.2 Proteus Software

The Proteus Design Suite is a proprietary software tool suite used primarily for electronic design automation. The software is used mainly by electronics design engineers and technicians to create schematics and electronic prints for manufacturing printed circuit boards. The first version of what is now the Proteus Design Suite was called PC-B and was written by the company chairman, John Jameson, for DOS in 1988. Schematic Capture support followed in 1990 with a port to the Windows environment shortly thereafter. Mixed-mode SPICE Simulation was first integrated into Proteus in 1996 and microcontroller simulation then arrived in Proteus in 1998. Shape-based auto-routing was added in 2002 and 2006 saw another major product update with 3D Board Visualization. More recently, a dedicated IDE for simulation was added in 2011 and MCAD import/export was included in 2015. Support for the high-speed design was added in 2017. Feature led product releases are typically biannual, while maintenance based service packs are released as required.[2]

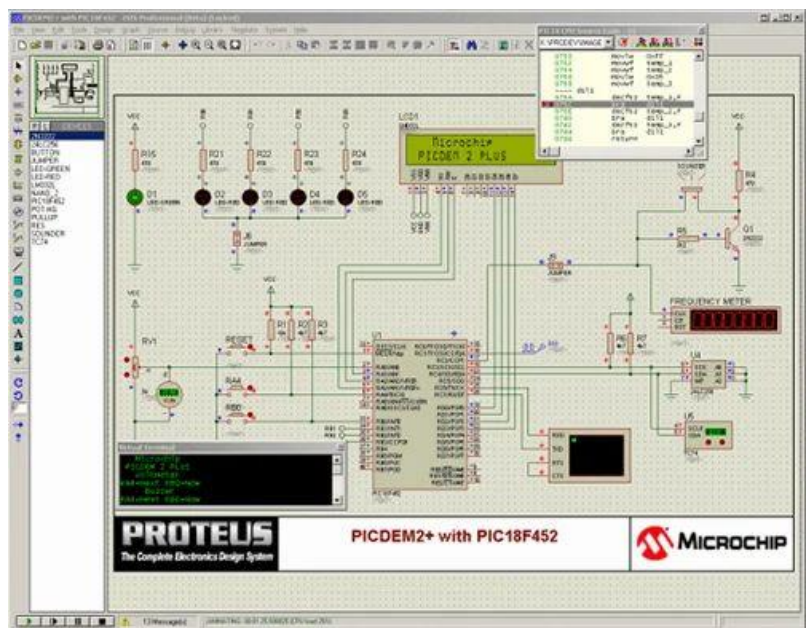

Figure 4.2: Proteus Software Interface

4.3 Microcontroller Simulation

The micro-controller simulation in Proteus works by applying either a hex file or a debug file to the microcontroller part on the schematic. It is then co-simulated along with any analog and digital electronics connected to it. This enables its use in a broad spectrum of project prototyping in areas such as motor control, temperature control and user interface design. It also finds use in the general hobbyist community and, since no hardware is required, is convenient to use as a training or teaching tool. Support is available for co-simulation of:[3]

- Microchip Technologies PIC10, PIC12, PIC16, PIC18, PIC24, dsPIC33 Microcontrollers.
- Atmel AVR (and Arduino), 8051 and ARM Cortex-M3 Microcontrollers
- NXP 8051, ARM7, ARM Cortex-M0, and ARM Cortex-M3 Microcontrollers.
- Texas Instruments MSP430, PICCOLO DSP, and ARM Cortex-M3 Microcontrollers.
- Parallax Basic Stamp, Free scale HC11, 8086 Microcontrollers.

4.4 PCB Design

The PCB Layout module is automatically given connectivity information in the form of a netlist from the schematic capture module. It applies this information, together with the user- specified design rules and various design automation tools, to assist with error free board design. PCB's of up to 16 copper layers can be produced with design size limited by a product configuration.[3]

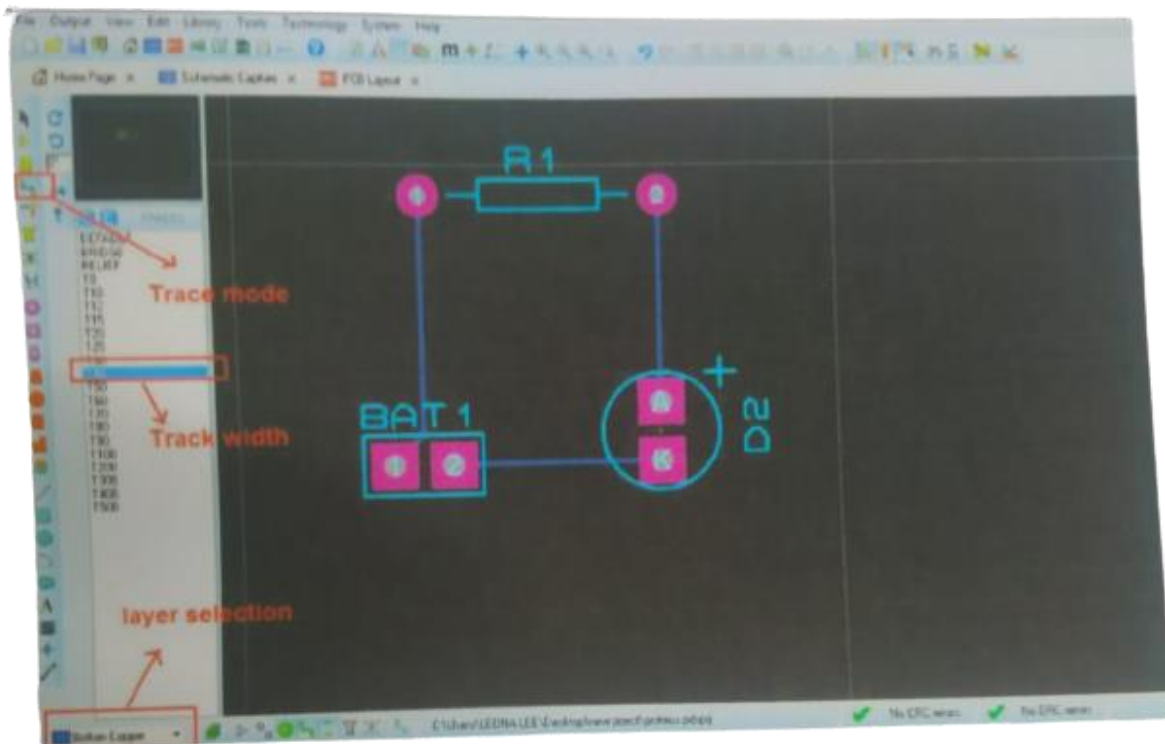

Figure 4.3: PCB Design

4.5 3D Verification

The 3D Viewer module allows the board under development to be viewed in 3D together with a semi-transparent height plane that represents the board's enclosure. STEP output can then be used to transfer to mechanical CAD software such as Solid works or Autodesk for accurate mounting and positioning of the board.[2]

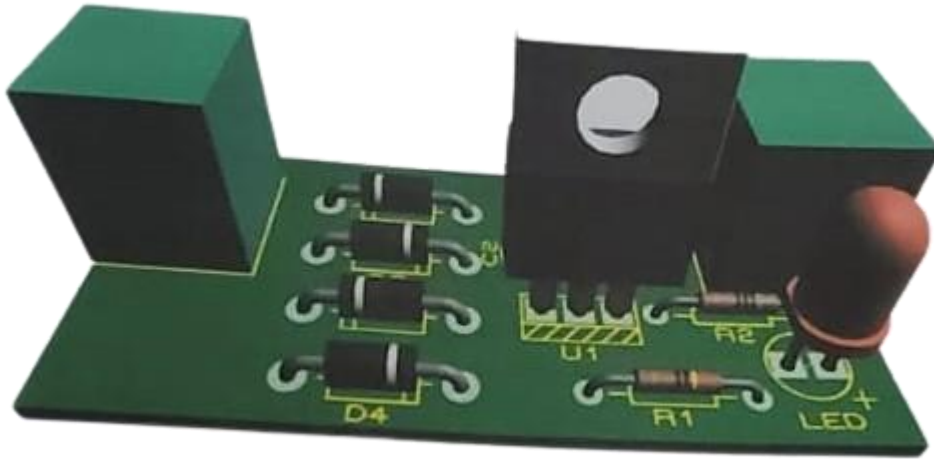

Fig 4.4: 3D verification

CHAPTER 5

PROPERTIES RESULT

5.1 Properties Result:

Property	value
Rated voltage	12v
No load speed	291 RPM
No load current	2.7 Ampere
Gear ratio	1: 61
Rated torque	9.02 Nm
Rated speed	260 RPM
Rated current	18.7 Ampere

For one reaction of the motor, the hacksaw moves two times linearly with only one effective cutting stroke. Therefore, the cutting speed is calculated using the following formula:

$$\text{Cutting speed} = \frac{\pi DN}{60} = \pi * 100 * 10^{-3} * 300 = 94.2477 \text{ m/min}$$

Rfl pipe length = 3mm

Rfl pipe diameter = 1 inch

Cutting time = 4 minutes

Blade size = 12 inc

CHAPTER 6

DISCUSSION & CONCLUSION

6.1 Discussion

It is known that conventional power hacksaw machines can be replaced with automated power Hacksaw machine. Automated power hacksaw machine gives high productivity in a short time period in comparison with the conventional power hacksaw machines. The major advantage of this machine is the intervention of labor is reduced to the maximum level. In this rapidly emerging industrial section, the use of power Hacksaw machine is wide, time and labor play a major role in the production process. This can be overcome by using this type of automated machines. The automated hacksaw machine can be made use of at any of the industries like pump manufacturing industries that involve a bulk amount of shafts that have to be cut frequently. The range of size of work-pieces that can be cut using the automated hacksaw machine can be varied by changing the blade size. Currently, the machine uses a 12- inch blade for cutting. Another advancement that can be implemented in automated hacksaw machines is that the user can also get cut work-pieces of different lengths in one cycle itself. This means that the user has to specify the number of workpieces that have to be cut in each of the different length values specified. This will be possible with the help of an advanced PLC than Arduino Nano, which should have a high programmable memory.

6.2 Advantages

- Relatively low capital investment required
- Tooling and maintenance cost are low
- Accuracy and finishes produced, ranging from fair to good depending on the material being sawed.

6.3 Applications

This the project of automatic double hacksaw, it can be used several systems for cutting the wood metal etc.

Performing operations like wood and metal cutting operations so it can be used for small, medium and large scale industries.

6.4 Future Scope

In the future, it can be developed with more featured.

- It can be added with more sensors within this system.
- It can be added to multiple Hacksaw system.
- It can be added to remotely control system.

References

- [1] Anthony and Dr. Esposito "Applied Hydraulic and Pneumatic", Lakshmi publication (P).Ltd, 2014.
- E[2] Dr.N. Selvaraj, "Electrical Drives and Controls", A.R.Publications (p).Ltd, 2013.
- [3] Mamimegalai and Pabita, "Electronics and Microprocessor", laxmi publication (p).Ltd, 2013.
- [4] R.K.Rajput "Manufacturing Technology-I", New Age publications (p).Ltd, 2014.
- [5] Dr.G.K.Vijayaraghavan, "Manufacturing Technology- II", Lakshmi publication (p).Ltd, 2014.
- [6] Anthony Esposito 'Fluid Power with applications', 6th Edition, Pearson Education Inc. 2011.
- [7] Muhammad Ali Mazidi, Janice Gillispie Mazidi, and Rolin D. McKinlay 'The 805 Micro Controller and Embedded Systems', 2nd Edition, Pearson Education Inc. 2008
- [8] Mohieddine Jelali and Andreas Kroll. Hydraulic Servo-systems, Modeling Identification, and Control. Springer, second edition, 2004.
- [9] Standard blade sizes used in power hacksaw machines using the link <http://www.planomillers.com/> - viewed on August 2, 2013

APPENDIX

```
Code: const int buttonPin = 2;      // the number of the pushbutton pin
const int ledPin = 13;             // the number of the LED pin
// variables will change:
Appendix
int buttonState = 0;               // variable for reading the pushbutton status
void setup() {
// initialize the LED pin as an output:
pinMode(ledPin, OUTPUT);
// initialize the pushbutton pin as an input:
pinMode(buttonPin, INPUT);
}
void loop() {
// read the state of the pushbutton value:
buttonState = digitalRead(buttonPin);
// check if the pushbutton is pressed. If it is, the buttonState is HIGH: {
if (buttonState HIGH) {
// turn LED on:
digitalWrite(ledPin, HIGH);
} else {
// turn LED off:
digitalWrite(ledPin, LOW);
}
}
```