



UGC & Govt. Approved  
**Sonargaon University (SU)**  
সোনারগাঁও ইউনিভার্সিটি (এসইউ)

## “Thermoelectric Refrigeration System”

A Thesis

By

Md. Mehedi Hasan	ID: BME-2001020453
Shohel Rana	ID: BME-2001020483
Md. Shohel Rana	ID: BME-2001020482
Tushar paul	ID: BME-2001020428
Shahadat Hossain	ID: BME-1802015270

### Supervisor

M.I. Washif Rahman

Lecturer

Department of Mechanical Engineering

**Sonargaon University (SU)**

**Dhaka-1215, Bangladesh**

**September, 2023**

# “Thermoelectric Refrigeration System”

A report submitted to the Department of Mechanical, Sonargaon University of Bangladesh in partial fulfillment of the requirements for the Award of Degree of Bachelor of Science in Mechanical Engineering.

## Submitted by

MD. Mehedi Hasan	ID: BME-2001020453
Shohel Rana	ID: BME-2001020483
Md. Shohel Rana	ID: BME-2001020482
Tushar paul	ID: BME-2001020428
Shahadat Hossain	ID: BME-1802015270



## Supervised by

M.I. Washif Rahman  
Lecturer  
Department of Mechanical Engineering  
**Sonargaon University (SU)**  
**Dhaka-1215, Bangladesh**

**September, 2023**

# LETTER OF TRANSMITTAL

September, 2023

To

M.I. Washif Rahman

Lecturer

Department of Mechanical Engineering.

Sonargaon University of Bangladesh

**Subject: Submission of Project Report.**

Dear Sir,

We are pleased to submit the project report on “**Thermoelectric Refrigeration System**”.

It was a great pleasure to work on such an important topic. This project has been done as per instruction of your supervision and according to the requirements of the Sonargaon University.

We expect that the project will be accepted by the concerned authority we will remain happy to further explanation that you may feel necessary in this regard.

Thank You

Sincerely yours,

MD. Mehedi Hasan

BME-2001020453

Tushar paul

BME-2001020428

Shohel Rana

BME-2001020483

Shahadat Hossain

BME-1802015270

Md. Shohel Rana

BME-2001020482

# DECLARATION

We do hereby solemnly declare that, the work presented here in this project report has been carried out by us and has not been previously submitted to any University/ Organization for award of any degree or certificate

We hereby ensure that the works that has been prevented here does not breach any existing copyright.

We further undertake to indemnify the university against any loss or damage arising from breach of the foregoing obligation.

MD. Mehedi Hasan  
BME-2001020453

Tushar Paul  
BME-2001020428

Shohel Rana  
BME-2001020483

Shahadat Hossain  
BME-1802015270

Md. Shohel Rana  
BME-2001020482

## ACKNOWLEDGEMENT

First, we started in the name of almighty Allah. This thesis is accomplished under the supervision of M.I. Washif Rahman, Lecturer, Department of Mechanical, Sonargaon University. It is a great pleasure to acknowledge our profound gratitude and respect to our supervisor for this consistent guidance, encouragement, helpful suggestion, constructive criticism and endless patience through the progress of this work. The successful completion of this thesis would not have been possible without his persistent motivation and continuous guidance.

The authors are also grateful to **Md. Mostofa Hossain**, Head of the Department of Mechanical Engineering and all respect teachers of the Mechanical Engineering Department for their co-operation and significant help for completing the thesis work successfully.

# **ABSTARCT**

The "Thermoelectric Refrigeration System with Peltier Effect" project aims to design and construct a compact and efficient cooling system utilizing the Peltier effect. This solid-state Thermoelectric cooling system is designed to maintain a controlled low temperature for various applications. The core components include a Peltier module, a Switched-Mode Power Supply (SMPS) for power regulation, a water cooling block as a heat sink, a pump motor for efficient heat dissipation, and a temperature sensor with a display for real-time monitoring. The Peltier module, functioning as the cooling element, is powered by the SMPS, which provides stable and adjustable DC power. The Peltier module transfers heat from one side to another, achieving cooling on the cold side and heating on the hot side. A water cooling block enhances heat dissipation from the hot side, while a pump motor circulates water to maintain efficient cooling. A temperature sensor positioned strategically measures the system's temperature, and the data is displayed in real time for monitoring and control.

# TABLE OF CONTENTS

Letter of Transmittal	ii
Declaration	iii
Acknowledgement	iv
Abstract	v
Table of Contents	vi
Table of Figure	viii
<b>CHAPTER-1</b>	<b>INTRODUCTION</b>
1.1 Introduction	1
1.2 Background Study	2
1.3 Objective	3
1.4 Structure of the Projects	3
<b>CHAPTER 2</b>	<b>LITERATURE REVIEW</b>
2.1 Introduction	5
2.2 Literature Review	5
2.3 Summary	8
<b>CHAPTER-3</b>	<b>HARDWARE AND SOFTWARE ANALYSIS</b>
3.1 SMPS	9
3.2 Peltier	14
3.3 Water Cooling Block	16
3.4 Plastic Pipe	18
3.5 Digital Thermometer	19
3.6 High Speed Pump	21
3.7 Easy EDA Software	21
<b>CHAPTER-4</b>	<b>METHODOLOGY</b>
4.1 Methodology	23
4.2 Working Step Chart	23

4.3 Block Diagram	24
4.4 Schematic Diagram	24
4.5 Working Principle	25
4.6 Our Final Project View	25
<b>CHAPTER-5</b>	<b>RESULT AND DISCUSSION</b>
5.1 Result	27
5.2 Calculation	28
5.3 Discussion	29
5.2 Advantages	29
5.3 Application	29
<b>CHAPTER-6</b>	<b>CONCLUSION</b>
6.1 Conclusion	30
6.2 Future Scope	30
<b>Reference</b>	<b>31</b>



# LIST OF FIGURES

<b>FIGURE NO</b>	<b>FIGURE NAME</b>	<b>PAGE NO</b>
3.1	SMPS	9
3.2	Basic Working Principle of an SMPS	11
3.3	SMPS Diagram	12
3.4	DC Power Supply Way	13
3.5	Peltier Cooler	14
3.6	Construction of Peltier	15
3.7	Heat Sink	17
3.8	Plastic Pipe	19
3.9	Digital Temperature Sensor	19
3.10	Temperature Sensor Display	20
3.11	High Speed Pump	21
3.12	Easy EDA Software Interface	22
4.1	Working Step Chart	23
4.2	Block Diagram	24
4.3	Schematic Diagram	24
4.4	Our Final System Overview (Front View)	25
4.5	Our Final System Overview (Side View)	26

# CHAPTER 1

## INTRODUCTION

### 1.1 Introduction

The Peltier effect is used in Thermoelectric refrigeration (TEC), which is the direct conversion of electrical energy into heat and cold. Thermoelectric refrigeration has many benefits over traditional compressors, which include small size, no noise, long life, precise temperature control, and no need for refrigerant. Because of these advantages, it has a high application value in refrigeration, electronic device cooling, LED lamp cooling, and medical device temperature control. However, its cooling capacity is limited, the coefficient of performance (COP) is lower than that of compressors, and this obstacle has prompted researchers to pursue new ways to elevate efficiency. Researchers have conducted extensive research to try to improve the cooling performance of Thermoelectric modules. In general, there are two ways to improve Thermoelectric cooling efficiency.

Change the inherent properties of the materials inside the TEC module, such as changing the geometry and length of thermocouples, segmenting P-type and N-type thermocouples, or researching the constituent materials of thermocouples to improve the figure of merit. However, when the TEC is in use, its inherent internal properties cannot be changed, which requires another method to improve its cooling performance. Based on the existing Thermoelectric modules, improve the thermal design and optimization of the Thermoelectric refrigeration system. He et al. stated that improving heat dissipation conditions can improve the cooling performance of Thermoelectric cooling units and the system's COP value.

When optimizing Thermoelectric cooling modules, the hot side heat dissipation conditions should be prioritized. For the heat dissipation of TEC equipment, the most commonly used cooling methods are air cooling, heat pipe cooling, liquid cooling, phase change material cooling, and so on. Liu et al. established five different cooling methods and explored the effects of different cooling methods on the COP of Thermoelectric refrigeration modules through experiments. The better the cooling performance, the higher the average COP of the Thermoelectric device.

Riffat et al. designed a phase change material heat sink and found that good heat dissipation performance can increase the refrigeration performance of the entire system. Astrain et al. proposed a phase change siphon principle Thermoelectric cooling module hot side heat dissipation device. Through analytical calculations, computational fluid dynamics simulation, and experimental verification phase change siphon heat dissipation can increase the refrigeration performance by 32%. Karwa et al. designed a low-thermal-resistance water-cooled heat sink. Through CFD simulation and 3D printing technology, the experimental test results proved that the water-cooled heat sink had a low thermal resistance value, which further improved the refrigeration performance of the Thermoelectric refrigeration module.

Cuce et al. used comprehensive experimental methods to investigate the effect of nano fluid heat dissipation on the cooling performance of Thermoelectric refrigeration modules and discovered that different types of nano fluids have better thermal conductivity than pure water. The COP of Thermoelectric cooling is enhanced by enhancing the hot-end's heat dissipation performance. Summarizing the above techniques, researchers are more interested in improving the Thermoelectric refrigeration system's thermal performance than changing the Thermoelectric material's internal structural parameters when it comes to improving the refrigeration performance of Thermoelectric devices. Experiments have shown that high-performance heat sinks can optimize the Thermoelectric refrigeration system's performance, but increase energy consumption.

## **1.2 Background Study**

On the other hand, in the above research, the efficiency of the Thermoelectric system is improved through the design of a new type of heat dissipation system, but the new type of system designed requires additional space and thermal budget. For this reason, plate finned heat sinks are a good choice. Researchers have conducted extensive research on the plate-fin heat sink and further optimized the radiator. For example, the shape of the fins becomes cylindrical, conical, rectangular, trapezoidal, irregular, and arranged irregularly to improve its heat dissipation performance. In this regard, a new type of finned heat sink is designed for use in the heat dissipation of the hot-end of the Thermoelectric refrigeration system. As far as the author knows, this new type of finned radiator has not been studied by previous researchers.

To improve the performance of the Thermoelectric cooler, this study proposes two new types of hot-end heat sinks under the premise that the external dimensions of the hot-end heat sink of the Thermoelectric cooling module remain unchanged. The new heat sink enhances the general system's heat dissipation performance, further improving the Thermoelectric device's refrigeration performance. It also has the advantage of consuming less power and taking up less space. Finally, experiments are conducted to verify the effectiveness of the new heat sink in improving the cooling performance of the Thermoelectric refrigeration system under different working conditions.

### 1.3 Objective

We have some specific objectives for this project and they are pointed below:

- To Study about **Design and Construction of a Thermoelectric Refrigeration System with Peltier Effect.**
- To design **Thermoelectric Refrigeration System with Peltier Effect.**
- To construct **Thermoelectric Refrigeration System with Peltier Effect.**
- To analyze the cooling effect of **Thermoelectric Refrigeration System with Peltier Effect.**

### 1.4 Structure of the Project

This Project is organized as follows:

**Chapter 1 Introduction:** The first chapter contains the statement of the introduction, our background study for the project, objectives of the study, methodology used in the project and the project outline.

**Chapter 2 Literature Review:** The chapter two contains our literature review part.

**Chapter 3 Hardware and Software Analysis:** Chapter three describes the theoretical model. Here we mainly discuss about Hardware and software development of our project etc.

**Chapter 4 Methodology:** Here we mainly discuss about proposed system architecture in details with having block diagram, circuit diagram, project working principle, complete project image of our project etc.

**Chapter 5 Results and Discussion:** Chapter five deals with the result, advantages, application and discussion about our project advantages and application.

**Chapter 6 Conclusion:** all about our project conclusion, limitations and future scope.

# CHAPTER 2

## LITERATURE REVIEW

### 2.1 Introduction

In this section topics related to **Design and Construction of a Thermoelectric Refrigeration System** are included. These provide a sampling of problems appropriate for application of **Thermoelectric Refrigeration System**. The references are summarized below.

### 2.2 Literature Review

*Jincan Chena et al.,[1]:-* According to non-equilibrium thermodynamics ,cycle models of single-stage and two-stage semiconductor Thermoelectric refrigeration were experimentally investigated. By using the three important parameters which governs performance of Thermoelectric refrigerator i.e. coefficient of performance (COP), the rate of refrigeration, and the power input, development of general expressions performances of the two-stage Thermoelectric refrigeration system took place. It was concluded that performance of Thermoelectric refrigerator depends on temperature ratio of heat sink to cooled space. When this ratio is small, the maximum value of COP of a two-stage Thermoelectric refrigeration system is larger than COP of a single-stage Thermoelectric refrigeration system; however maximum rate of refrigeration is smaller than that of a single-stage Thermoelectric refrigeration system. Hence it is convenient to use single stage Thermoelectric refrigerator when ratio is small. When temperature ratio is large two stage Thermoelectric refrigerator is observed to be superior than single stage by both parameters i.e. maximum value of COP and maximum rate of refrigeration.

*X.C. Xuan et al., [2]:-* In this paper Two stage Thermoelectric refrigerator was investigated with two design configurations. Two configurations were pyramid style and cuboid style as shown in respective figures. In pyramid style configuration top side is being coldest as current is unidirectional. In cuboid style configuration current can be alternated causing top and bottom side to be switched between heating and cooling mode. To obtain optimization methods other multi stage designs can be used. The point of maximum cooling capacity and maximum COP both were taken into consideration while

investigation for optimization for the two-stage TE coolers. It was concluded that value lies between 2.5-3 for both parameters that is optimum limit of ratio of number of thermoelectric modules of two stages in pyramid style TE cooler and optimum limit of ratio of electric current between stages of cuboid style TE cooler. Maximum temperature difference of pyramid-style cooler is greater than single stage cooler.

**Jun Luo et al., [3]:-** Using finite time Thermodynamics theory performance of a Thermoelectric refrigeration system, with multi elements was analyzed. To improve and maximize the cooling load and coefficient of performance (COP) optimization of the ratio of the heat transfer surface area of the high temperature side to the total heat transfer surface area of the heat exchangers was done. The analysis of number of parameters which affects optimum performance of Thermoelectric system was done , parameters were number of Thermoelectric refrigerating elements, the See back coefficients, internal heat conductance, the heat source temperature and internal electrical resistance. As well as the analysis of other parameters like influences of total heat transfer surface area and working electrical current on the optimum performance was done. They concluded that the cooling load and coefficient of performance (COP) of TE system is greatly influenced by total heat transfer surface area and working electrical current. These results can be used for designing and manufacturing of practical Thermoelectric refrigerators.

**D. Astrain et al.,[4]:-** In this paper a device using phase change material based on Thermosyphon principle was developed. This device was used and tested as a heat dissipater for hot side of TE cooler. Performance of TE cooler with this device was compared with TE cooler with conventional heat dissipater made up of fins. It was concluded that with the help of developed phase changing device it is possible to reduce thermal resistance between hot side of TE cooler and atmosphere up to 23.8% at 293 K ambient temperature and 51.4% at 308 K ambient temperature, compared to commercial finned heat sink . Decrease in thermal resistance ultimately causes heat to dissipate more effectively from heat sink of TE cooler, therefore improving the COP of TE cooler. At the same values of temperatures it was observed that COP increases by 26% and 35% respectively.

***Yuzhuo Pan, et al, [5]:-*** Author of this paper designed and analyzed an Irreversible multi-couple Thermoelectric refrigerator, which operates between two reservoirs maintained at constant temperature. Effect of other factors like external and internal irreversibility of Thermoelectric refrigerator on performance was also studied. They have specified many important parameters which affects coefficient of performance (COP) of system. Results of obtained from experiments leads to knowledge of information about performance characteristics of real multi-couple Thermoelectric refrigerator. This information may be used to manufacture and design Thermoelectric refrigerator which will perform at its optimum level.

***Hongxia Xi.et al, [6]:-*** In this paper Author done survey on solar based driven Thermo electric technology. A brief history of development of solar based driven Thermo electric technology was presented. It's today's status and drawbacks present in current Technologies were reviewed. Applications, future scope, advantages over conventional technology where also discussed. In this paper they have discussed about two main modes, that are solar based Thermoelectric power generation and refrigeration. Current status of both Technologies was described. Problems related to this technology and there possible solutions were presented. Ultimately these Technologies with some more development may lead to solve demand of Environment protection and energy conservation.

***Suwit Jugsujinda et al, [7]:-*** In this paper they have fabricated Thermoelectric refrigerator using Thermoelectric cooler. Thermoelectric refrigerator ( $25 \times 25 \times 35 \text{ cm}^3$ ) and Thermoelectric cooler ( $4 \times 4 \text{ cm}^2$ ). This system was applied to 40 W electric power without any cooling fan as heat dissipater at heat sink. They have measured temperature of this system at ten different points. It was concluded that these experiments results into temperature of cold side of Thermoelectric cooler to be decreased from  $30^\circ\text{C}$  to  $-4.2^\circ\text{C}$  for 1 hour and decreased to  $-7.4^\circ\text{C}$  for 24 hours with heat plate temperature being  $50^\circ\text{C}$ . Temperature of cold side of Thermoelectric refrigerator decreased from  $30^\circ\text{C}$  to  $20^\circ\text{C}$  for 1 hour and decreased further in 24 hours. 3 and 2.5 are the maximum value of coefficient of performance (COP) of Thermoelectric cooler and Thermoelectric refrigerator respectively.



*S.A.Omer et al, [8]:-* This paper presents some results of Thermoelectric refrigeration system using phase change materials (PCM) integrated with thermosyphons. They investigated two models of Thermoelectric refrigeration system, one with conventional finned devices as heat dissipater and other with phase change material (PCM) as heat dissipater. After results they have concluded that coefficient of performance (COP) and effectiveness of Thermoelectric refrigeration system with Phase Change Material (PCM) is higher than conventional one. They have also compared Thermoelectric refrigeration system of two kinds, one is using phase change materials (PCM) without thermal diode and other integrated with thermal diode (Thermosyphons ). Results shows that thermosyphons used prevent leakage of heat during power off. Overall they have concluded system can be work with the help of renewable energies like solar energy producing electricity. It is suited for medicine and food storage.

### **2.3 Summary**

This project involves the creation of an efficient Thermoelectric refrigeration system using Peltier modules, a Switched-Mode Power Supply (SMPS), a water cooling block, a pump motor, and a temperature sensor with a display. The Peltier modules are powered by the SMPS to create a temperature difference, with one side getting hot and the other cold. A water cooling block and pump motor efficiently dissipate the heat generated by the hot side of the Peltier modules. A temperature sensor continuously monitors the target space or device, and a display provides real-time temperature feedback for precise control. This integrated system offers controlled and stable cooling, making it suitable for various applications such as electronics cooling, beverage chilling, or temperature-sensitive devices.

# CHAPTER 3

## HARDWARE AND SOFTWARE ANALYSIS

### 3.1 Switch Mode Power Supply (SMPS)

A switched-mode power supply (switching-mode power supply, switch-mode power supply, switched power supply, SMPS, or switcher) is an electronic power supply that incorporates a switching regulator to convert electrical power efficiently. Like other power supplies, an SMPS transfers power from a DC or AC source (often mains power) to DC loads, such as a personal computer, while converting voltage and current characteristics.



Figure 3.1 : SMPS

Unlike a linear power supply, the pass transistor of a switching-mode supply continually switches between low-dissipation, full-on and full-off states, and spends very little time in the high dissipation transitions, which minimizes wasted energy. A hypothetical ideal switched-mode power supply dissipates no power. Voltage regulation is achieved by varying the ratio of on-to-off time (also known as duty cycles). In contrast, a linear power supply regulates the output voltage by continually dissipating power in the pass transistor. This higher power conversion efficiency is an important advantage of a switched-mode

power supply. Switched-mode power supplies may also be substantially smaller and lighter than a linear supply due to the smaller transformer size and weight. Switching regulators are used as replacements for linear regulators when higher efficiency, smaller size or lighter weight are required. They are, however, more complicated; their switching currents can cause electrical noise problems if not carefully suppressed, and simple designs may have a poor power factor.

Switched-mode power supplies are classified according to the type of input and output voltages. The four major categories are:

- AC to DC
- DC to DC
- DC to AC
- AC to AC

A basic isolated AC to DC switched-mode power supply consists of:

- Input rectifier and filter
- Inverter consisting of switching devices such as MOSFET
- Transformer
- Output rectifier and filter
- Feedback and control circuit

The input DC supply from a rectifier or battery is fed to the inverter where it is turned on and off at high frequencies of between 20 KHz and 200 KHz by the switching MOSFET or power transistors. The high-frequency voltage pulses from the inverter are fed to the transformer primary winding, and the secondary AC output is rectified and smoothed to produce the required DC voltages. A feedback circuit monitors the output voltage and instructs the control circuit to adjust the duty cycle to maintain the output at the desired level.

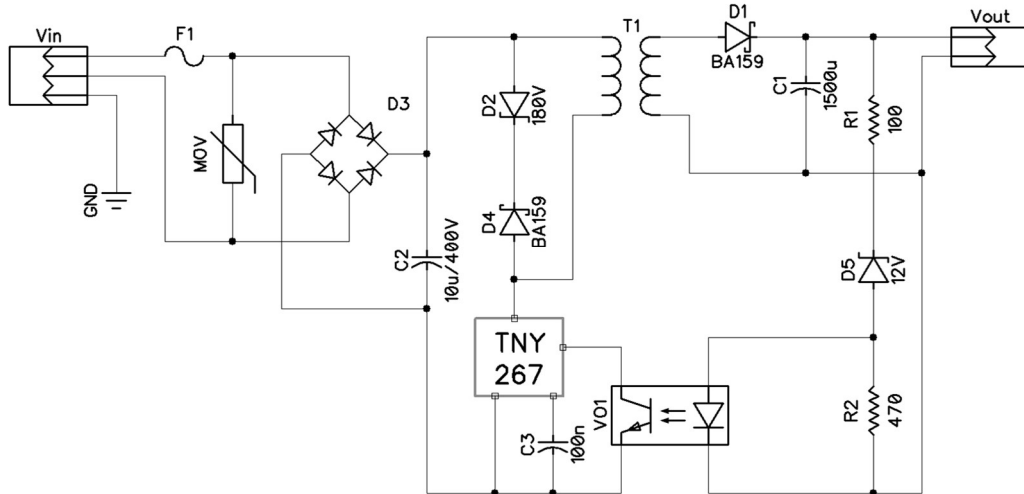

Figure 3.2: Basic working concept of an SMPS [18]

A switching regulator does the regulation in the SMPS. A series switching element turns the current supply to a smoothing capacitor on and off. The voltage on the capacitor controls the time the series element is turned. The continuous switching of the capacitor maintains the voltage at the required level.

### Design basics

AC power first passes through fuses and a line filter. Then it is rectified by a full-wave bridge rectifier. The rectified voltage is next applied to the power factor correction (PFC) pre-regulator followed by the downstream DC-DC converter(s). Most computers and small appliances use the International Electro technical Commission (IEC) style input connector. As for output connectors and pin outs, except for some industries, such as PC and compact PCI, in general, they are not standardized and are left up to the manufacturer.

There are different circuit configurations known as topologies, each having unique characteristics, advantages and modes of operation, which determines how the input power is transferred to the output. Most of the commonly used topologies such as fly back, push-pull, half bridge and full bridge, consist of a transformer to provide isolation, voltage scaling, and multiple output voltages. The non-isolated configurations do not have a transformer and the power conversion is provided by the inductive energy transfer.

### Advantages of switched-mode power supplies:

- Higher efficiency of 68% to 90%
- Regulated and reliable outputs regardless of variations in input supply voltage
- Small size and lighter
- Flexible technology
- High power density

### Disadvantages:

- Generates electromagnetic interference
- Complex circuit design
- Expensive compared to linear supplies

Switched-mode power supplies are used to power a wide variety of equipment such as computers, sensitive electronics, battery-operated devices and other equipment requiring high efficiency.

### Switch Mode Power Supply

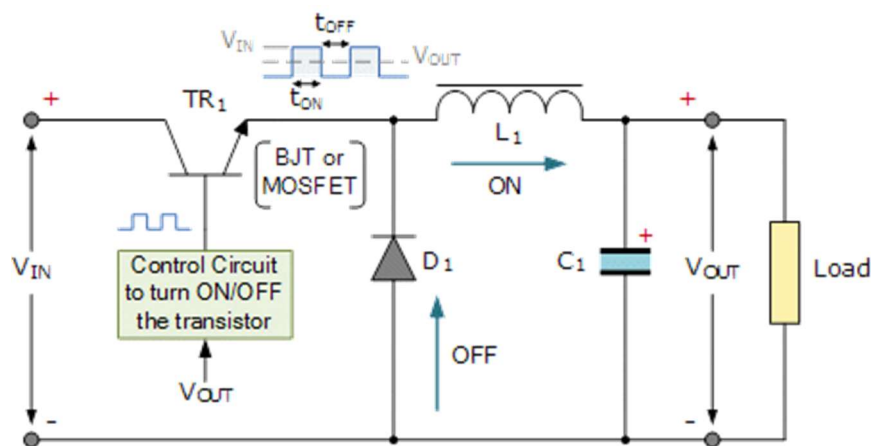

Figure 3.3 : SMPS Diagram [19]

Linear voltage IC regulators have been the basis of power supply designs for many years as they are very good at supplying a continuous fixed voltage output. Linear voltage regulators are generally much more efficient and easier to use than equivalent voltage

regulator circuits made from discrete components such a zener diode and a resistor, or transistors and even op-amps. The most popular linear and fixed output voltage regulator types are by far the 78... positive output voltage series, and the 79... negative output voltage series. These two types of complementary voltage regulators produce a precise and stable voltage output ranging from about 5 volts up to about 24 volts for use in many electronic circuits.

There is a wide range of these three-terminal fixed voltage regulators available each with its own built-in voltage regulation and current limiting circuits. This allows us to create a whole host of different power supply rails and outputs, either single or dual supply, suitable for most electronic circuits and applications. There are even variable voltage linear regulators available as well providing an output voltage which is continually variable from just above zero to a few volts below its maximum voltage output. Most d.c. power supplies comprise of a large and heavy step-down mains transformer, diode rectification, either full-wave or half-wave, a filter circuit to remove any ripple content from the rectified d.c. producing a suitably smooth d.c. voltage, and some form of voltage regulator or stabilizer circuit, either linear or switching to ensure the correct regulation of the power supplies output voltage under varying load conditions. Then a typical d.c. power supply would look something like this:

### Typical DC Power Supply

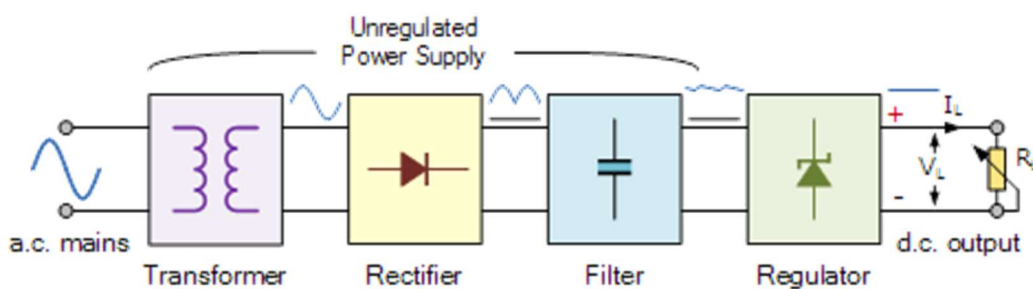

Figure 3.4: DC Power supply way [20]

These typical power supply designs contain a large mains transformer (which also provides isolation between the input and output) and a dissipative series regulator circuit. The regulator circuit could consist of a single zener diode or a three-terminal linear series

regulator to produce the required output voltage. The advantage of a linear regulator is that the power supply circuit only needs an input capacitor, output capacitor and some feedback resistors to set the output voltage. [11]

### 3.2 Peltier

A **Peltier** cooler, heater, or Thermoelectric heat pump is a solid-state active heat pump which transfers heat from one side of the device to the other, with consumption of electrical energy, depending on the direction of the current.



Figure 3.5 : Peltier Cooler [21]

The TEC1-12706 40x40mm Thermoelectric Cooler 0~6A Peltier Module is the simple application of Peltier Thermoelectric Effect. Thermoelectric coolers also are known as TEC or **Peltier Module** create a temperature differential on each side. One side gets hot and the other side gets cool. Therefore, they can be used to either warm something up or cool something down, depending on which side you use. You can also take advantage of a temperature differential to generate electricity.

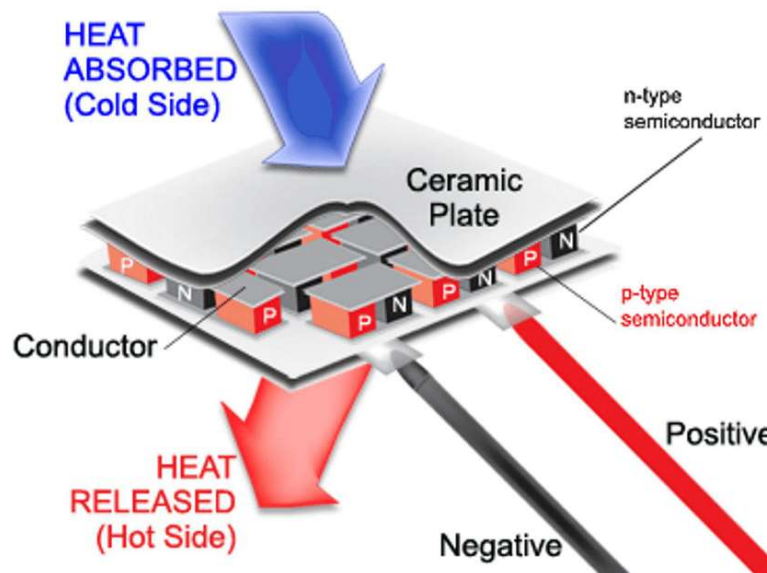
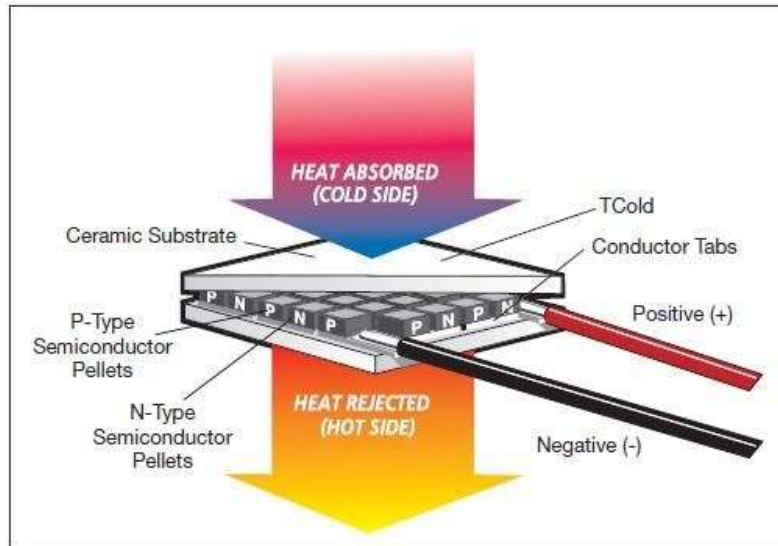

Figure 3.6 : Construction of Peltier [22]

Two unique semiconductors, one n-type and one p-type, are used because they need to have different electron densities. The semiconductors are placed thermally in parallel to each other and electrically in series and then joined with a thermally conducting plate on each side. When a voltage is applied to the free ends of the two semiconductors there is a flow of DC current across the junction of the semiconductors causing a temperature difference. The side with the cooling plate absorbs heat which is then moved to the other side of the device where the heat sink is. Thermoelectric Coolers, also abbreviated to TECs are typically connected side by side and sandwiched between two ceramic plates.



The cooling ability of the total unit is then proportional to the number of TECs in it. This Peltier works very well as long as you remove the heat from the hot side. After turning on the device, the hot side will heat quickly, the cold side will cool quickly. If you do not remove the heat from the hot side (with a heat sink or other device), the Peltier will quickly reach stasis and do nothing. We recommend using an old computer CPU heatsink or another block of metal to pull heat from the hot side. We were able to use a computer power supply and CPU heat sink to make the cold side so uncomfortable we could not hold our finger to it.

A Thermoelectric cooling (TEC) module is a semiconductor-based electronic component that functions as a small heat pump. By applying the DC power source to a TEC, heat will be transferred from one side of the module to the other. It creates a cold and hot side. They are widely used in industrial areas, for example, computer CPU, CCDs, portable refrigerators, medical instruments, and so on. Also Known as Thermoelectric cooling modules, Thermoelectric modules, Peltier modules, Thermoelectric cooling module.

**Features:**

1. Small module.
2. Easy transition between the hot side to the cool side and vice-versa just by reversing the polarity of supply.
3. Quality tested cooling cells.
4. Solid state, vibration free, noise-free.
5. Simple to install and operate.
6. Should use with a heat sink. [12]

### **3.3 Aluminum Water Cooling Block Heat sink**

A **heat sink** (also commonly spelled **heat sink**) is a passive heat exchanger that transfers the heat generated by an electronic or a mechanical device to a fluid medium, often air or a liquid coolant, where it is dissipated away from the device, thereby allowing regulation of the device's temperature. In computers, heat sinks are used to cool CPUs, GPUs, and some chipsets and RAM modules. Heat sinks are used with high-power semiconductor devices such as power transistors and optoelectronics such as lasers and light emitting diodes

(LEDs), where the heat dissipation ability of the component itself is insufficient to moderate its temperature.



Figure 3.7 : Heat Sink [23]

## Description

- Aluminum Water Cooling Block for CPU Heat sink Cooler Peltier Plate  
80x40x12mm
- Internal flow channel extrusion forming
- Brazing parts into a whole
- Leak rate of less than  $5 \times 10^{-6}$  mbar.l/s parts
- Internal fin thickness 0.5MM
- Connection: 9 mm id tubes
- Processing: vacuum aluminum brazing
- Surface treatment: silver oxidation
- Applicable to computer CPU water, industrial inverter driver, laser head cooling, industrial control cabinet cooling, Thermoelectric Cooler
- Size:80 (D) x 40 (W) x 12 (H) MM [13]

### 3.4 Plastic Pipe

**Plastic pipe** is a tubular section, or hollow cylinder, made of plastic. It is usually, but not necessarily, of circular cross-section, used mainly to convey substances which can flow liquids and gases (fluids), slurries, powders and masses of small solids. It can also be used for structural applications; hollow pipes are far stiffer per unit weight than solid members.

#### Product Description:

<b>Product Name:</b>	clear pvc tubing
<b>Material:</b>	pvc
<b>Size:</b>	from 1/8inch (ID 3mm) to 2inch (ID 50mm)
<b>Wall Thickness:</b>	from 1mm to 4mm
<b>Color:</b>	clear / blue / red / yellow / black / green / orange etc.
<b>Working Pressure:</b>	from 2bar (30psi) to 4bar (60psi)
<b>Temperature Range:</b>	from -5 to 65 degree C.
<b>Length/roll</b>	10m, 20m, 30m, 50m/roll or other.

#### Application:

Suitable for low pressure transfer of various Fluids and air, such as fuel, water, light chemicals, oxygen, gas for watering systems, peristaltic pumps, electrical and thermal insulation, analytical systems in plant equipment, laboratories, watering system and many other low pressure industry applications. [14]



Figure 3.8 : Plastic Pipe [24]

### 3.5 Digital Thermometer

A thermometer is a device that measures temperature or a temperature gradient (the degree of hotness or coldness of an object). A thermometer has two important elements: a temperature sensor (e.g. the bulb of a mercury-in-glass thermometer or the pyrometric sensor in an infrared thermometer) in which some change occurs with a change in temperature.



Figure 3.9: Digital Temperature Sensor

some means of converting this change into a numerical value (e.g. the visible scale that is marked on a mercury-in-glass thermometer or the digital readout on an infrared model). Thermometers are widely used in technology and industry to monitor processes, in

meteorology, in medicine, and in scientific research. Some of the principles of the thermometer were known to Greek philosophers of two thousand years ago. As Henry Carrington Bolton (1900) noted, the thermometer's "development from a crude toy to an instrument of precision occupied more than a century, and its early history is encumbered with erroneous statements that have been reiterated with such dogmatism that they have received the false stamp of authority." The Italian physician Santorio Santorio (Sanctorius, 1561-1636) is commonly credited with the invention of the first thermometer, but its standardization was completed through the 17th and 18th centuries. In the first decades of the 18th century in the Dutch Republic, Daniel Gabriel Fahrenheit made two revolutionary breakthroughs in the history of thermometry. He invented the mercury-in-glass thermometer (first widely used, accurate, practical thermometer) and Fahrenheit scale (first standardized temperature scale to be widely used).



Figure 3.10: Digital Temperature Sensor Display

### Specification

- Temperature range:  $-50 \sim +110^{\circ}\text{C}$
- Using environment: Temperature:  $-5 \sim +50^{\circ}\text{C}$  Humidity: 5%~80%
- Accuracy:  $\pm 1^{\circ}\text{C}$
- Size: 47\*28\*14mm
- Weight: 22g
- Color: Black and white [15]

### 3.6 High Speed Pump



Figure 3.11: High Speed Pump

#### Feature:

- Pump Operating Voltage: 12V
- Power: 8W Max
- Working Pressure: 160Psi (10.5 Bar) Cutoff
- Cutoff Automatic Switch
- Flow (MAX): 10L/min
- Pressure Adjustable Copper Head Water Spray
- Water Pressure Limit : Adjustable
- Sprayers Size : 20cm
- Spray Distance: 9 m
- Thread Diameter: 1.5cm
- Main Material: Copper, Plastic
- Power supply Voltage: 12V DC
- Power supply Current: 5A [16]

### 3.7 Easy EDA Software

Easy EDA is a web-based EDA tool suite that enables hardware engineers to design, simulate, share - publicly and privately - and discuss schematics, simulations and printed circuit boards. Other features include the creation of a bill of materials, Gerber files and pick and place files and documentary outputs in PDF, PNG and SVG formats. Easy EDA

allows the creation and editing of schematic diagrams, SPICE simulation of mixed analogue and digital circuits and the creation and editing of printed circuit board layouts and, optionally, the manufacture of printed circuit boards.

Subscription-free membership is offered for public plus a limited number of private projects. The number of private projects can be increased by contributing high quality public projects, schematic symbols, and PCB footprints and/or by paying a monthly subscription. Registered users can download Gerber files from the tool free of charge; but for a fee, Easy EDA offers a PCB fabrication service. This service is also able to accept Gerber file inputs from third party tools. [17]

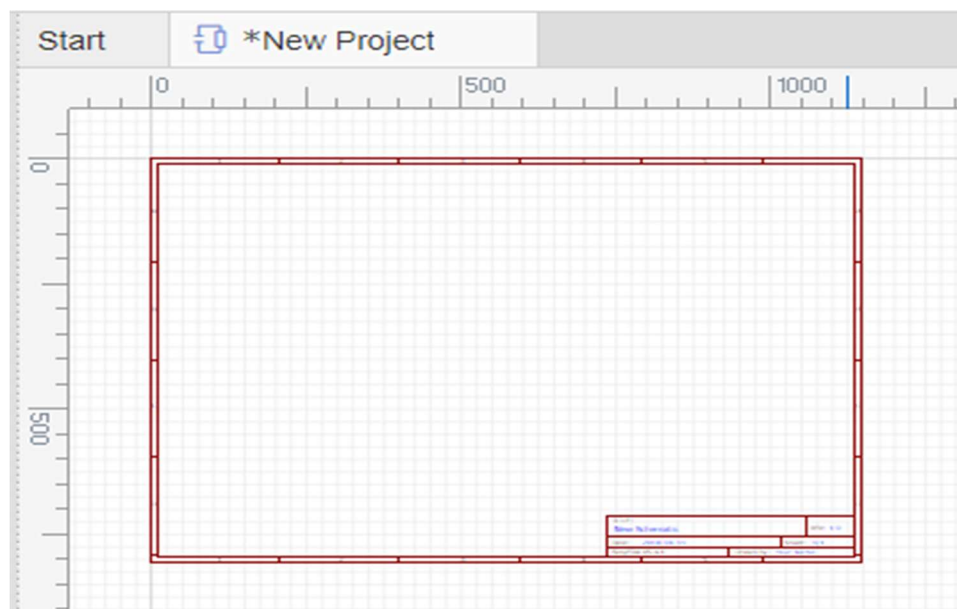

Figure 2.14: Easy EDA Software Interface [25]

# CHAPTER 4

## METHODOLOGY

### 4.1 Our methodologies for the project

Our methodologies for the project:

- Creating an idea for **Thermoelectric Refrigeration System**. And designing a block diagram & circuit diagram to know which components we need to construct it.
- Collecting all the components of our system.
- Setting up all the components in a PCB board & then soldering. Lastly, assembling all the blocks in a board and to run the system & for checking purposes.

### 4.2 Working Step Chart

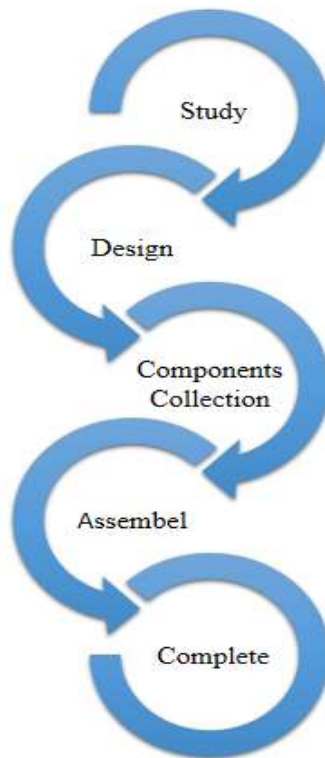

Figure 4.1: Working Step Chart [26]



### 4.3 Block Diagram

The way of whole project works is that we take 220V AC power from the supply voltage and then feed it to a Switch Mode Power Supply or in short SMPS module. The SMPS simply converts the 220V AC to a pure DC of 12V 20Amp. We will use this 12V DC output from the SMPS to run our controller, motor and other units.

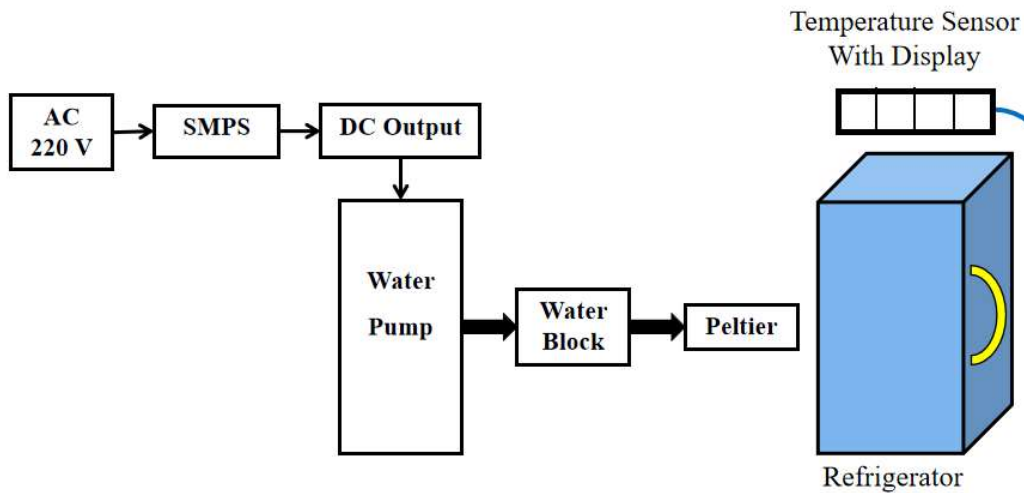

Figure 4.2: Block Diagram of Our System

### 4.4 Schematic Diagram

The schematic diagram here is representing the electrical circuit and the components of the project. Here we have used standardized symbols and lines.

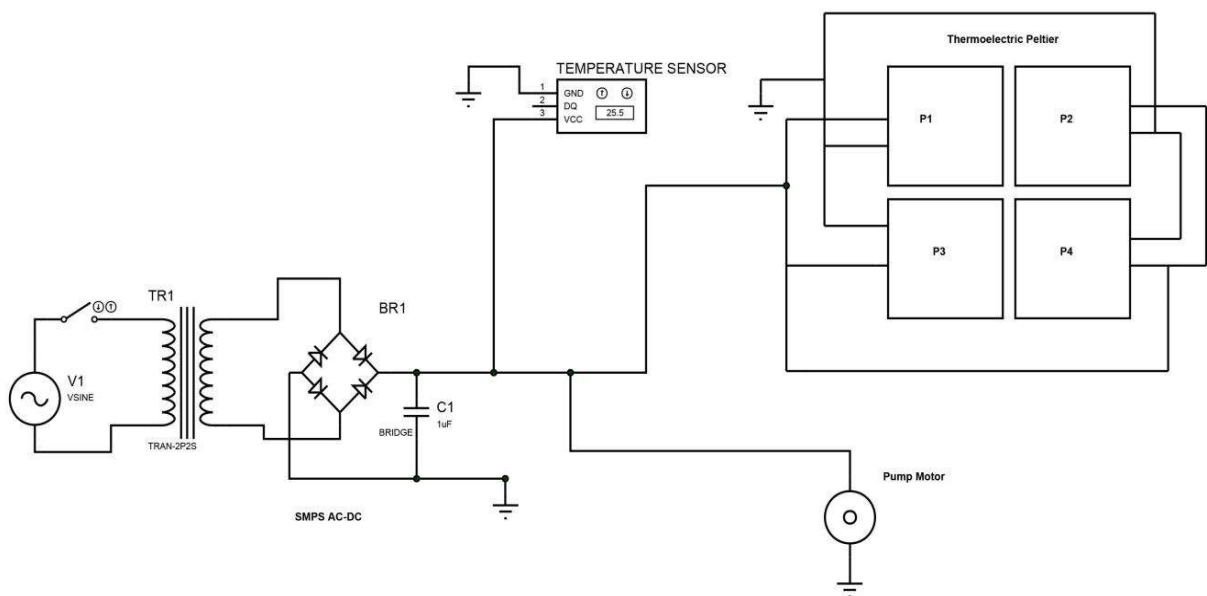

Figure 4.3: Schematic Diagram of the Project

#### **4.5 Working Principle**

Our main power supply for this system is AC 220 voltage. This power is connected to the SMPS. The main function of SMPS is to convert AC to DC. Since all our instruments in this project are DC, we need DC power. This SMPS will be supply fixed 12V DC, 20Amp in this system. Here we use peltier, water block, temperature sensor, aluminium sheet etc. Firstly we on the power button to system on. Then motor will be rotate the tank water. After that water goes in water block, then the water pass through the peltier and system produce cool inside of this system. This is the main function of our system.

#### **4.6 Our Final System View**



Figure 4.4: Our Final System Overview (Front View)



Figure 4.5: Our Final System Overview (Side View)

# CHAPTER 5

## RESULT AND DISCUSSION

### 5.1 Result

Now, it's time to talk about the results. We have written our commands using the following things can happen:

- After power this project then it will be able to operate.
- Here we use a submersible pump to flow our liquid.
- Inside of the refrigerator temperature is normal.
- After starting flow of water it will be cool .
- All the cool data will be show in temperature system.

**Data:**

Data Part	Time (Minute)	Temperature (°C)
01	01 min	30 °C
02	02 min	25 °C
03	04 min	20 °C
04	05 min	17°C
05	06 min	15 °C

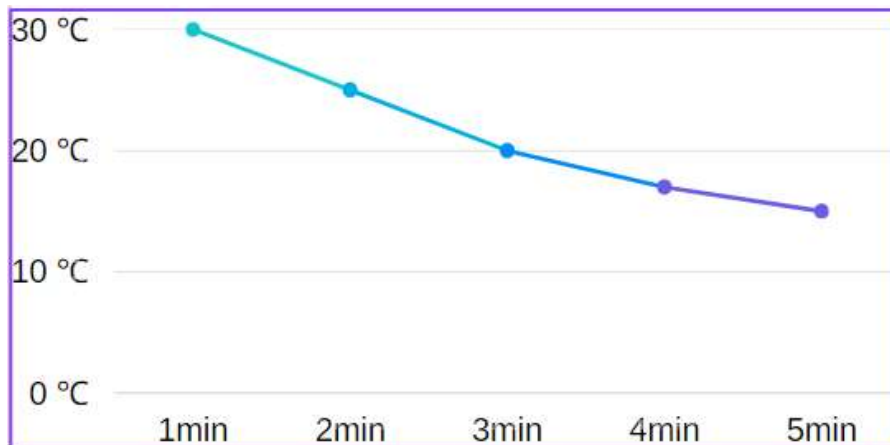

## 5.2 Calculation

Output DC Voltage = 12V

Power = 8w = 0.008kw

For Temperature 30 °C - 15°C

$$\text{COP} = \frac{T_{min}}{T_{max} - T_{min}}$$

$$= \frac{288}{303 - 288}$$

$$= 19.2$$

$$T_{max} = (30 + 273) \text{ k}$$

$$= 303 \text{ k}$$

$$T_{min} = (15 + 273) \text{ k}$$

$$= 288 \text{ k}$$

∴ Load = 0.008 kw

∴ Per Unit = (0.008 × 0.1)

= 0.0008kwh

Time = 6 Min

= 0.1 hr

day = 30 day

## 5.2 Discussion

While working on our project, we did face some difficulties as it is a very complex system but the end results, we came up with were quite satisfactory. We have put the whole system through several tasks to validate our work and also have taken necessary notes for future improvements. Some future recommendations that we have involves improvement in system design and wiring, adding features for more efficient.

## 5.3 Advantage

There are many advantages of our project because of its accuracy. Some of the advantages are pointed out below:

- Creates a comfortable and productive work environment.
- Improve inside refrigeration Air Quality.
- Energy-efficient cooling solution.
- Environmentally friendly.

- No Oil consumption.
- Less skill technicians is sufficient to operate.
- Installation is simplified very much.
- Simple construction
- Easy of operation.

## **5.4 Application**

Some of the application areas of the project have been pointed out below:

- It can be used for small purpose.
- It can be use for indoor purpose

# CHAPTER 6

## CONCLUSION

### 6.1 Conclusion

The main objective of this project was to develop a refrigeration cycle system based on certain specifications. This was successfully implemented. We consider this project as a journey where we acquired knowledge and also gained some insights into the subject which we have shared in this report. In a refrigeration system capillary tube is more adjustable and better device. The initial and running cost of this system is really less. No outside energy source is required to run the system. This refrigeration system has wide scale application in hotel industries, chemical industries.

### 6.2 Future Scope

We are thinking about adding many features to our project in the future to get more desirable outcomes. Some of the steps that we are thinking about taking are given below:

- In future, we are looking forward to improving our whole system design to make it more efficient.
- In future we will add coolant liquid.
- In future, we are thinking about adding more features to the system such as automatic heat sensor, deep fridge system.
- In future, we are thinking about making the system IoT enabled so that wirelessly the whole system can be observed or ON/Off.

## REFERENCE

- [1] Jincan Chen, Yinghui Zhou, Hongjie Wang, Jin T. Wang: “ Comparison of the optimal performance of single- and two-stage Thermoelectric refrigeration systems” *Applied Energy* 73 (2002) 285–298
- [2] X.C. Xuan,K.C.Ng,C.Yap,H.T.Chua: “Optimization of two-stage Thermoelectric coolers with two design configurations” *Energy Conversion and Management* 43 (2002) 2041–2052
- [3] Jun Luo,Lingen Chen,Fengrui Sun,Chih Wu: “Optimum allocation of heat transfer surface area for cooling load and COP optimization of a Thermoelectric refrigerator” *Energy Conversion and Management* 44 (2003) 3197–3206
- [4] D.Astrain,J.G.Vian,M.Dominguez: “Increase of COP in the Thermoelectric refrigeration by the optimization of heat dissipation” *Applied Thermal Engineering* 23 (2003) 2183–2200
- [5] Yuzhuo Pan, Bihong Lin, Jincan Chen,: “Performance analysis and parametric optimal design of an irreversible multi-couple Thermoelectric refrigerator under various operating conditions” *Applied Energy* 84 (2007) 882–892
- [6] Hongxia Xi, Lingai Luo, Gilles Fraisse: “Development and applications of solar-based Thermoelectric technologies” *Renewable and Sustainable Energy Reviews* (2007) 923–936
- [7] Suwit Jugsujinda, Athorn Vora-ud, Tosawat Seetawan: “Analysing of Thermoelectric Refrigerator Performance” *Procedia Engineering* 8 (2011) 154–159
- [8] S.A.Omar,S.B.Raffit,Xiaoli Ma: “experimental investigation of Thermoelectric refrigeration system employing a phase change material integrated with thermal diode (thermosyphons)”*Applied thermal Engineering* 21(2001)1265-1271



- [9] Manoj S. Raut, Dr.P. V. Walke, “Thermoelectric Air Cooling For Cars”, International Journal of Engineering Science and Technology (IJEST), Vol. 4 No.05 May 2012 ,ISSN : 0975-5462.
- [10] Mr. Swapnil B. Patond,“ Experimental Analysis of Solar Operated Thermo-Electric Heating and Cooling System”, International Journal of Engineering Trends and Technology (IJETT) – Volume 20 Number 3 – Feb 2015 , ISSN: 2231-5381.
- [11] [https://www.google.com/search?q=smps&rlz=1C1CHBF\\_enBD1029BD1029&oq](https://www.google.com/search?q=smps&rlz=1C1CHBF_enBD1029BD1029&oq)  
.
- [12] [www.thermonamic.com/?gclid=CjwKCAjw6poBhAYEiwAgg2Pgp8BjUrmaijKrbH5iK\\_tZiDHy\\_wFM90HQkvx\\_](http://www.thermonamic.com/?gclid=CjwKCAjw6poBhAYEiwAgg2Pgp8BjUrmaijKrbH5iK_tZiDHy_wFM90HQkvx_)
- [13] [https://www.google.com/search?q=Aluminum+Water+Cooling+Block+Heat+sink&sca\\_esv=566202829&rlz](https://www.google.com/search?q=Aluminum+Water+Cooling+Block+Heat+sink&sca_esv=566202829&rlz)
- [14] [https://www.google.com/search?q=Plastic+Pipe&sca\\_esv=566202829&rlz](https://www.google.com/search?q=Plastic+Pipe&sca_esv=566202829&rlz).
- [15] [https://www.google.com/search?q=DIGITAL+THERMOMETER&sca\\_esv=566202829&rlz](https://www.google.com/search?q=DIGITAL+THERMOMETER&sca_esv=566202829&rlz)
- [16] <https://www.ksb.com/en-global/centrifugal-pump-lexicon/article/high-speed-centrifugal-pump-1117920>
- [17] [https://www.google.com/search?q=easy+eda+software&rlz=1C1CHBF\\_enBD1029BD1029&oq=easy+eda+software&gs\\_lcrp](https://www.google.com/search?q=easy+eda+software&rlz=1C1CHBF_enBD1029BD1029&oq=easy+eda+software&gs_lcrp)
- [18] [https://www.google.com/search?sca\\_esv=565923685&rlz=1C1CHBF](https://www.google.com/search?sca_esv=565923685&rlz=1C1CHBF)
- [19] <https://www.google.com/search?q=SMPS+Diagram&tbm=isch&ved>
- [20] <https://www.google.com/search?q=DC+Power+supply+way&tbm=isch&ved>

- [21] <https://www.google.com/search?q=Peltier+Cooler&tbm=isch&ved=2ahUKEwjJ6tuJqK>
- [22] <https://www.google.com/search?q=Construction+of+Peltier&tbm=isch&ved>
- [23] <https://www.google.com/search?q=Heat+Sink&tbm=isch&ved=2ahUKEwj8p>
- [24] <https://www.google.com/search?q=Heat+Sink&tbm=isch&ved=2ahUKEwj8p>
- [25] <https://www.google.com/search?q=Easy+EDA+Software+Interface+&tbm>
- [26] <https://www.google.com/search?q=Working+Step+Chart&tbm=isch&ved>.