

# DUAL AXIS SOLAR PANEL TRACKING SYSTEM



## SUBMITTED BY

Sohel Rana	BME2001020514
Md. Amdadul Hoque	BME2001020512
Mohammed Saiful Gani Chowdhury	BME2001020613
Md Iftakhar Alam Asif	BME2001020670
Md. Mehedi Hasan Kabir	BME2001020666

A Graduation Exercise Submitted to the Department of Mechanical Engineering in Partial Fulfillment of the Requirements for the Degree of Bachelor of Mechanical Engineering

**DEPARTMENT OF MECHANICAL ENGINEERING  
SONARGAON UNIVERSITY (SU)  
DHAKA, BANGLADESH**

**SEPTEMBER, 2023**

## DECLARATION

We do hereby solemnly declare that, the work presented here in this project report has been carried out by us and has not been previously submitted to any University/Organization for award of any degree of certificate

We hereby ensure that the works that has been prevented here does not breach any existing copyright.

We further undertake to indemnify the university against any loss or damage arising from breach of the foregoing obligation

.....

Sohel Rana  
BME 2001020514

.....

Md. Amdadul Hoque  
BME 2001020512

.....

Mohammed Saiful Gani Chowdhury  
BME 2001020613

.....

Md Iftakhar Alam Asif  
BME 2001020670

.....

Md. Mehedi Hasan Kabir  
BME 2001020666

## **Certification**

This is to certify that this project entitled “**DUAL AXIS SOLAR PANEL TRACKING SYSTEM**” is done by the following students undermy direct supervision. This project work has been carried out by them in the laboratories of the Department of Mechanical Engineering under the Faculty of Engineering, Sonargaon University (SU) in partial fulfillment of the requirements for the degree of Bachelor of Science in Mechanical Engineering.

### **Supervisor**

**Md. Mostofa Hossain**

.....

Professor & Head

Department Of Mechanical Engineering

Sonargaon University (SU)

Dhaka -1215, Bangladesh

## ACKNOWLEDGEMENT

The report titled as on “**DUAL AXIS SOLAR PANEL TRACKING SYSTEM**” has been prepared to fulfil the requirement of our practicum program. In the process of doing and preparing our practicum report, we would like to pay our gratitude to some persons for their enormous help and vast co-operation.

At first, we would like to show our gratitude to the University authority to permit us to do our practicum. Specially, we would like to thank to our honorable teacher **Md. Mostofa Hossain**, Professor & Head, Department of Mechanical Engineering, Sonargaon University (SU), Dhaka, for his valuable and patient advice, sympathetic assistance, co-operation, contribution of new idea. Deep theoretical and hardware knowledge & keen interest of our supervisor in this field influenced us to carry out this project. His endless patience, scholarly guidance, continual encouragement, constant and energetic supervision, constructive criticism, valuable advice, reading many inferior drafts and correcting them at all stage have made it possible to complete this project.

Finally, we would like to thank again to the respected **Vice-Chancellor of SU, Professor Dr. Md. Abul Bashar** Department of Mechanical Engineering because they are designated such an environment for learning through which we got the opportunity to acquire knowledge under B.sc in ME program, and that will be very helpful for our prospective career.

We are, indeed, grateful to all those from whom we got sincere co-operation and help for the preparation of this report.

## ABSTRACT

This is a project of **DUAL AXIS SOLAR PANEL TRACKING SYSTEM**. The project is about making two axis solar panel tracker that can be working robotic system. The Solar Tracker is a device which follows the movement of the sun. We used four LDR (Light Dependent Resistor). They are light sensitive devices. They are also called as photo conductors. The working principle of an LDR is photo conductivity, that is nothing but an optical phenomenon. When the light is absorbed by the material then the conductivity of the material reduces. We use two servo motor. Servos are controlled by sending an electrical pulse of variable width. A servo motor can usually only turn  $90^\circ$  in either direction for a total of  $180^\circ$  movement. we use to PIC16F877 microcontroller. The microcontroller is there for controlling automatically. We use 7805 regulator IC, 10uF capacitor, 100uF capacitor 1pcs. We use LCD (Liquid Crystal Display) display. The microcontroller is there for programming language C++. The main objective of our project is to utilize the maximum solar energy through solar panel. The solar panel tracks the sun from east to west automatically for maximum intensity of light also ensure that the tracking system design and components are cost-effective, making it a viable option for both residential and commercial solar installations. After testing and result we get that dual-axis solar tracking systems generate on average 15-30% more energy compared to static systems.

In conclusion, the dual-axis solar tracking system offers significant advantages in maximizing the efficiency and output of solar panels. By continuously aligning the panels with the sun's position throughout the day, the system ensures optimal solar energy absorption, resulting in improved power generation.

## TABLE OF CONTENTS

Declaration	ii
Certification	iii
Acknowledgement	iv
Abstract	v
Table of Contents	vi
Table of Figure	x
List of Mathematical Symbols	xii
List of Abbreviations	xiii

## INTRODUCTION

### CHAPTER -1

1.1 Introduction	1
1.2 Research problem statement	2
1.3 Objectives:	2
1.4 Methodology of the study	3
1.5 Contribution of the study:	4
1.6 Arrangement of the study:	4
1.7 Future Scope of this study:	5
1.7.1. Future scope:	5
1.7.2. Recommendation:	6
1.8. Limitations of this study:	6
1.9. Advantage over traditional methods:	6
1.10. Objective of this work:	6

1.10.1. Primary objectives:	7
1.10.2. Secondary objectives:	7

## **LITERATURE REVIEW**

### **CHAPTER -2**

2.1. Introduction:	8
2.2. Historical Background:	8
2.3 Earlier Research:	9
2.3.1 Resent research:	9
2.4 Solar panel:	10
2.5 Block Diagram of This Proposed Project:	12
2.5.1 The Model of the Project:	13
2.6 Photovoltaic cell model:	13
2.6.1 IV curve for a PV cell:	14
2.7 Maximum Power Point Tracking (MPPT):	15
2.8 Solar Irradiation: Sunlight:	17
2.9 Types of Solar Trackers & System:	18
2.9.1 Single axis solar tracker:	18
2.9.2 Dual axis solar tracker:	19
2.9.3 Comparison between single and dual axis solar tracker:	19
2.9.4 Effect of the dust density on the inclination of solar panel:	19
2.9.5 Temperature Effect on Solar Panel:	20
2.10 Efficiency of Solar panel:	21
2.11 Advantages & Disadvantages of solar energy:	22
2.11.1. Advantages:	22
2.11.2. Disadvantages:	22

# HARDWARE DEVELOPMENT

## CHAPTER -3

3.1. LDR (Light Dependent Resistor):	23
3.1.1. Working Principle of LDR:	24
3.1.2 The Design and implementation of using Four LDRs:	24
3.1.3 The minimum light detectable Equation:	25
3.2 LCD (2 Line 16 Carriers):	26
3.2.1. Pin Features:	27
3.2.2 Pin Description:	27
3.3 Servo Motor:	28
3.3.1. Components of servo motor SG-90:	29
3.3.2. Servo Mechanism:	30
3.3.3. Working Principle of Servo Motor:	30
3.3.4. Servo Motor Control:	31
3.4. Microcontroller:	33
3.4.1 PIC16F877 Pin Diagram:	36
3.4.2. Block Diagram of PIC16F877A:	37
3.4.3. Pin and their functions:	38
3.4.4. The Features of PIC16F877:	40
3.4.5. PIC16F877 Development Board:	41
3.5. Voltage regulator:	41
3.5.1. Pin Description:	43
3.6. Capacitor:	43
3.7. 606-Transformer:	44
3.8 CCS C Compiler:	45
3.8.1 Key Compiler Features:	46



3.8.2. Proteus Design Suite:	46
------------------------------	----

## **RESULT AND ANALYSIS**

### **CHAPTER - 4**

4.1 Introduction	48
4.2 Comparison Output Values	49
4.3 Comparison Graph	50

## **CONCLUSIONS AND RECOMMENDATION**

### **CHAPTER – 5**

5.1 Summary	51
5.2 Recommendation	51
5.3 Discussions and Conclusions	52
5.3.1 Discussion:	52
5.3.2. Conclusion:	53
5.4 Suggestion for Future work:	54

## **List of Figure**

<b>No</b>	<b>Figure Name</b>	<b>Page</b>
1.1	Methodology of the study	3
2.1	Solar panel module	11
2.2	Block Diagram of this project	12
2.3	Model of this project	13
2.4	Photovoltaic cell block diagram	14
2.5	Iv Curve for Pv cell	15
2.6	Maximum Power tracking	16
2.7	Solar Irradiation sunlight	17
2.8	Single Axis solar tracking system	18
2.9	Dual Axis solar tracking system	21
3.1	Light Dependent Resistor	23
3.2	Quadrant wise LDR Positioning	24
3.3	The Sensing Element & Signal Processing	25
3.4	LCD	26
3.5	LCD (2*16) pin	27
3.6	Standard Servo motor SG-90	28
3.7	Physical Construction of Servo motor	29
3.8	Servo gear Assembly	32
3.9	Inside look of a Servo motor	32
3.10	Microcontroller	34
3.11	Basic block diagram of Microcontroller	35

3.12	PIC-16F877A Microcontroller pin diagram	36
3.13	Block Diagram of PIC16F877A	37
3.14	PIC-16F877A Microcontroller development board	41
3.15	Voltage Regulator	42
3.16	100f and 10 f capacitor	43
3.17	606 -Transformer	44
3.18	Soldering two wires	44
3.19	CCS – C Compiler	45
3.20	CCS – C Compiler	46
3.21	Programing Our project	47
4.1	Non-Tracking Solar System	49
4.1.2	Dual Axis Solar Tracking System	49
4.2	Comparison Graph	50

## LIST OF MATHEMATICAL SYMBOLES

<b>Symbols</b>	<b>Abbreviation</b>
%	Percent
=	Equal
+	Plus
-	Minus
/	Division
×	Multiplication

## LIST OF ABBREVIATIONS

<b>Words/Signs</b>	<b>Abbreviation</b>
h	Hour
s	Second
V	Voltage
I	Current
P	Power
MPPT	Maximum Power Point Tracking
LDR	Light Dependent Resistor
PV	Photovoltaic
DC	Direct Current
AC	Alternating Current
VOM	Volt-Ohm-Milliammeter
USB	Universal Serial Bus

# Chapter 1

## Introduction

### 1. 1. Introduction:

Though in this era electricity is one of the most important part of our life, approximately 1.6 billion people still living without electricity. It's only for the high cost of power grid building and maintains. This vast quantity of energy crisis can be meeting up by renewable energy across the developing world. As people are much concerned with the fossil fuel exhaustion and the environmental problems caused by the conventional power generation, renewable energy sources and among them photovoltaic panels and wind-generators are now widely used. So Solar Energy is a good choice for electric power generation. The solar energy is directly converted into electrical energy by solar photovoltaic module. Photovoltaic sources are used today in many applications such as battery charging, water pumping, home power supply, satellite power systems etc. They have the advantage of being maintenance and pollution-free but their installation cost is high and in most applications; they require a power conditioner (dc/dc or dc/ac converter) for load interface. Since PV modules still have relatively low conversion efficiency, the overall system cost can be reduced using high efficiency power conditioners which, in addition, are designed to extract the maximum possible power from the PV module. In PV power systems maximum power point trackers (MPPTs) has an important role. It's minimizing the output power of a PV system and also the arrow efficiency as well as its cost is lower than the other power system. An important characteristic of solar panels is that the available maximum power is provided only in a single operating point given by a localized voltage and current known, called Maximum Power Point (MPP). Another problem is that the position of this point is not fixed but it moves according to the irradiance, the temperature and load. Because of the relatively expensive cost of this kind of energy we must extract the maximum of watts of solar panels. In this project we develop a Microcontroller based dedicated MPPT controller for solar PV module based on the incremental conductance method. [1,2]

## **1.2 Research problem statement:**

Solar power, which is available only in fixed installations, is the major problem. The ability of power that can be generated is restricted as part of this issue. The other factor is that the solar tracking system's purchase price is very high for a family that uses more electricity than normal, so more than one solar panel will need to be installed to generate enough power. So, this concept is all about solving the problem that is solar tracking system will detect rotation. Usually fixed solar energy panels would not be directly oriented towards sunlight as a result of the continuous motion of the Earth. The solar tracking device is the larger solution for achieving full output power due to this method. This is the primary reason that why the project for the solar tracker is implements. The solar tracker must obey the sunlight in order to get additional power output. [1,2]

## **1.3 Objectives:**

The objectives of this project are:

- To utilize the maximum solar energy through solar panel.
- To develop and fabricate the necessary model.
- To design a system that traces the sunlight for solar panels.

## 1.4 Methodology of the study

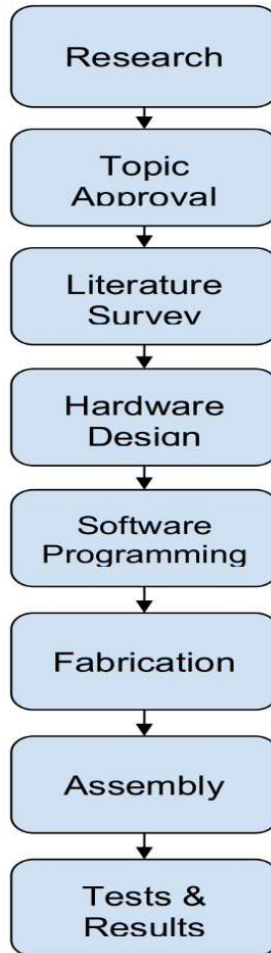

Figure 1.1 Flow chart of Methodology of the Study

**Research:** In Bangladesh, for both urban and rural residents, obtaining sufficient and dependable power is a key developmental problem. By using a solar tracker, the aim is to mitigate these issues by using the abundant sunlight available and to maximize efficiency by using the tracking mechanism.

**Topic Approval:** Upon analysis of the objectives the project was approved by the university panel.

**Literature Survey:** The project team reviewed multiple published papers on the concerned topic from notable websites such as [ieeexplore.ieee.org](http://ieeexplore.ieee.org), [ijert.org](http://ijert.org), etc.



**Hardware Design:** The necessary hardware components were designed using software tools such as solid works and certain digital component designs were utilized from online resources such as Proteus.

**Software Programming:** The software program necessary to operate the sun tracking solar panel was modified from existing programs for single-axis tracking systems to suit a dual-axis operation using C++.

**Fabrication:** All the necessary custom hardware components are fabricated using 3D printing facilities.

### **1.5 Contribution of the study:**

The solar energy plays a vital role among all this energy now. As it has a drawback that it can only generate power against the solar panel until the intensity associated with the incident of solar radiation. We developed the solar panel system to overcome this which shift in accordance with the direct intensity associated with the event of solar radiation. This can be accomplished by controlling the solar through the servo motor, the correct algorithm and the best mechanical configuration and the microcontroller. Since the effect would increase in both efficiency and low cost connected with the solar power technology. Limited sources of fossil fuels, such as petroleum and coal, which are available now leads to global warming due to CO<sub>2</sub> emissions [5]. The alternate source of energy is needed to reduce this type of emission. Energy from renewable sources such as solar, wind, geothermal and ocean tidal waves is being increasingly required to provide a reliable power supply and a safe environment for future generations. [8]

### **1.6 Arrangement of the study:**

- Complementing the introduction above, a through literature review of relevant work is presented in chapter 2. The review is accompanied by the motivation of present research.
- The research design, methodology of the research and different types of solar tracking systems are discussed in chapter 2.
- Chapter \* deals with the experiment result and analysis of the result from fixed, single axis and dual axis solar tracking system.

- Finally, the summary of observations and conclusions along with a brief reflection of future research are articulated in chapter

## **1.7 Future Scope of this study:**

Nearly everyone thinks that generating electricity via solar power is good for the environment. Renewable energy and solar in particular remain rather controversial in the public debate about energy policy. Demands of solar energy have been running high. What motivated us is the bewildering range of statements you have out there regarding the cost effectiveness of electricity based on solar PV. Given the range of opinions, that's why we wanted to do our own analysis. In a broad new assessment of the status and prospects of solar photovoltaic technology, MIT researchers say that it is "one of the few renewable, low-carbon resources with both the scalability and the technological maturity to meet ever-growing global demand for electricity." Use of solar photovoltaic has been growing at a phenomenal rate: Worldwide installed capacity has seen sustained growth averaging 43 percent per year since 2000. To evaluate the prospects for sustaining such growth, the MIT researchers look at possible constraints on materials availability, and propose a system for evaluating the many competing approaches to improved solar-cell performance.

### **1.7.1. Future scope:**

In future, solar energy will be very important source. So, using MPPT solar charge controller can generate a huge amount of current successfully. In this way, the cost of the production can also be reduced. In a word, it can develop a high-power output MPPT system with a low cost. This complete system schematic includes the feature of maintenance free use, no requirement of fuel or lubricant, stainless steel hardware, built-in over-load, over-charge, low voltage protection, temperature compensated charging and low battery disconnect facility. Moreover, it ensures maximum continuous power at full load and simultaneously pollution free and noiseless maintenance. Furthermore, it has the ability to charge the battery in low voltage so it will get sufficient backup in case of power failure.

### **1.7.2. Recommendation:**

Future studies into maximum power point tracking could include the use of a different DC/DC converter and also some different MPPT algorithm such as Current MPPT (CMPPT) for example, could be implemented. Another extension of this project could be to design the DC/DC converter in

full. The converter design could be done to optimize the components and in turn increasing the power efficiency. By optimizing the DC/DC converter the MPPT algorithms would achieve improved efficiencies and power tracking capabilities. Finally, a future work can also improve the developed software in order to efficiently use the capabilities of the microcontroller. A final prototype could then be design and implemented in order to have a final portable prototype for the solar charger. The whole system into a single integrated.

### **1.8. Limitations of this study:**

1. Computing with other analog system, it is costly.
2. Programming of microcontroller is complex.
3. It depends on temperature and radiation of sun.

### **1.9. Advantage over traditional methods:**

At first it is pollution free and reduces the waste of other using of MPPT algorithm increase the system's efficiency. The LCD Display helps the users to inform about the condition of charge. For microcontroller it's easy to use and ensures reliability the system.

### **1.10. Objective of this work:**

The main aim of our project is to utilize the maximum solar energy through solar panel. For this a digital based automatic sun tracking system is proposed. The solar panel tracks the sun from east to west automatically for maximum intensity of light. The Objectives are:

#### **1.10.1. Primary objectives:**

The main aim of our project is to utilize the maximum solar energy through solar panel. AS the cost of traditional current source is increasing day by day, people can take the advantage of renewable energy. With more and more portable devices coming out all the time the need to use renewable energy is ever increasing. The development of this thesis is very important because nowadays there is a current need in the market for an alternative Energy device that can charge different types of batteries efficiently. The developed charging process is not very fast but can ensure an efficient loading and without any additional cost for the final user. The total system can be used

both commercially and household generation. So, people can cover the crisis of electric energy, by their own-self. The total system, ensure the maximum efficiency with a low cost comparing other sources and generation system.

### **1.10.2. Secondary objectives:**

#### **Processes involved are:**

The solar panel tracks the sun from east to west automatically for maximum intensity of light. To fabricate two servo motors control interference with proposed circuit and construct a model prototype solar cell movement system with a mechanical assembly to move the panel from east to west as well as the sun track maximum angle. Finally, to design an electronic circuit to sense the intensity of light and to control servo motors drive for the panel movement. Ensure that the tracking system design and components are cost-effective, making it a viable option for both residential and commercial solar installations.

# Chapter 2

## Literature Review

### 2.1. Introduction:

Solar panel is made of tiny combination of solar cell and solar cell is the devices that are designed to convert light to electrical energy. Solar panel is mainly made from semiconductor materials such as silicon (Si), cadmium sulfide (CdS) and gallium arsenide (GaAs) can be used to make solar cells. The main purpose of using solar panel is getting the maximum energy by converting light energy to electric energy. Using solar tracker is the best way for getting the maximum energy because it's keeping the panels aligned with the sun's position and it's also an effective solution for get energy with solar panel.

### 2.2. Historical Background:

1839 – The Photovoltaic Effect: Edmond Becquerel, in 1839, discovered that when two electrodes were placed in an electrolyte (electricity-conducting solution), a voltage developed when light fell upon the electrolyte. The basic principles of solar power had been uncovered.

1876 – Electricity from Light: A King's College Professor, William Grylls Adams, and his student, Richard Evans Day, found in 1876 that selenium produced electricity when exposed to light. They attached platinum electrodes to selenium and observed a current in the electrodes when the selenium was exposed to light.

1883 – The First Working Solar Cell: American inventor Charles Fritts developed the first solar cell, applying selenium to a thin layer of gold. This method was only able to achieve 1% efficiency, making it impractical for general use.

1904 – Einstein's Paper on Light & Electrons: In the snappily titled "On a Heuristic Viewpoint Concerning the Production and Transformation of Light," Einstein set out for the first time the relationship between light and electrons. Although controversial at the time, it was gradually accepted

by the scientific community and led to his winning of the Nobel Prize in 1921. Later in 1916, Robert Millikan would experimentally prove “Einstein’s theory of the photoelectric effect”

1954 – A Major Breakthrough: Three researchers at Bell Labs — Daryl Chapin, Calvin Fuller, and Gerald Pearson discover silicon solar cells.

Late, 1950s – Increasing Efficiency: Throughout the late 50s, Hoffman electronics developed increasingly efficient solar cells. It started out initially at an 8% efficient cell in 1957, before eventually increasing to a 14%-efficient, commercially available cell in 1960.

### **2.3 Earlier Research:**

Early charge controllers were only able to reduce the amount of voltage from the PV panels if too high for the batteries. Since the voltage from the PV panels would be lower at high temperatures, the PV panels had to be over sized to ensure that the minimum voltage at high temperatures would be at least as high as the battery to be charged plus voltage headroom enough to force current into the battery. At any temperature lower than the maximum, the excess voltage from the PV panels would have to be discarded by the charge controllers. Because PV panels are the most expensive component of the system, the need for extra (or larger) PV panels negatively impacted the cost-effectiveness of such PV power systems. People those days could not use microcontroller for the management of the total system.

This system was first commercially introduced in Australia. Stuart Watkinson and his friend Barry James Aston was first founded “Australian Energy research Laboratories (AERL),” in September 1985.

The US department of Energy’s solar Energy research center in Colorado along with Florida State University’s solar research center at Cape Canaveral was also involved in early trials of the product. [2,3]

#### **2.3.1 Resent research:**

Newer and more efficient charger controllers have emerged that provide a better match between the PV panels and their load. Their goal is to use all the power from the PV panel(s) regardless of the voltage and current at any amount of insolation or at any temperature. The newer charge controllers

employ a DC-to-DC converter section that is adapted to dynamically charge the battery (or to directly power a load) at the exact voltage and current that is most appropriate for that battery (or load). Although the newer charge controllers provide improved system efficiencies relative to the older models, they too often suffer from several shortcomings. More particularly, the charge controllers are slow to adapt to changing conditions of the PV panel(s) over the course of any given day, including low light conditions in the morning, evening and during cloud cover and also temperature changes sometimes associated with the changes in insolation.

The edges of clouds create particularly issues because they cause a rapid change in lighting which may be followed by a relatively rapid change in temperature. Because they do not quickly adapt to changing conditions, the charge controllers have limited efficiency, which results in the need for extra (or larger) PV panels to be used for a given power output and high costs. Now-a-days all digital MPPT controllers are controlled microcontroller. They automatically adjust the output, move the panel for sunlight and also shut down for microseconds if necessary.

MPPT charge controllers are now commercially manufactured by several companies, such as outback power, Xantres XW-SCC, Blue Sky Energy, Apollo solar, Midnight solar, Morning star and a few others.

## **2.4 Solar panel:**

Solar panel is mainly designed as a panel which absorbed the sun's rays and convert light into electricity. Most of the time the most powerful source of light available is the Sun, called Sol by astronomers. It is called photovoltaic which means, basically, "light-electricity." [3,4]

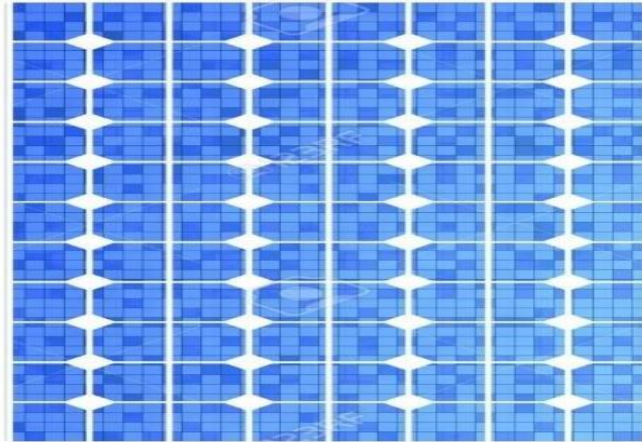

Fig 2.1: Solar panel Module

A solar panel is a collection of solar cells. Lots of small solar cells spread over a large area can work together to provide enough power to be useful. Solar power generating systems take advantage of this property to convert sunlight directly into electrical energy. Solar panels also called “solar modules produce direct current (DC), which goes through a power inverter to become alternating current (AC) — electricity that we can use in the home or office or other sectors.

When sunlight hits the semiconductor, an electron springs up and is attracted to the n-type semiconductor. This causes more negative electrons in the n-type semiconductor and more positive electrons in the p-type, thus generating a flow of electricity in a process known as the photovoltaic effect. The majority of solar modules use wafer-based crystalline silicon cells or thin-film cells based on cadmium telluride or silicon.



**Block Diagram of This Proposed Project:**

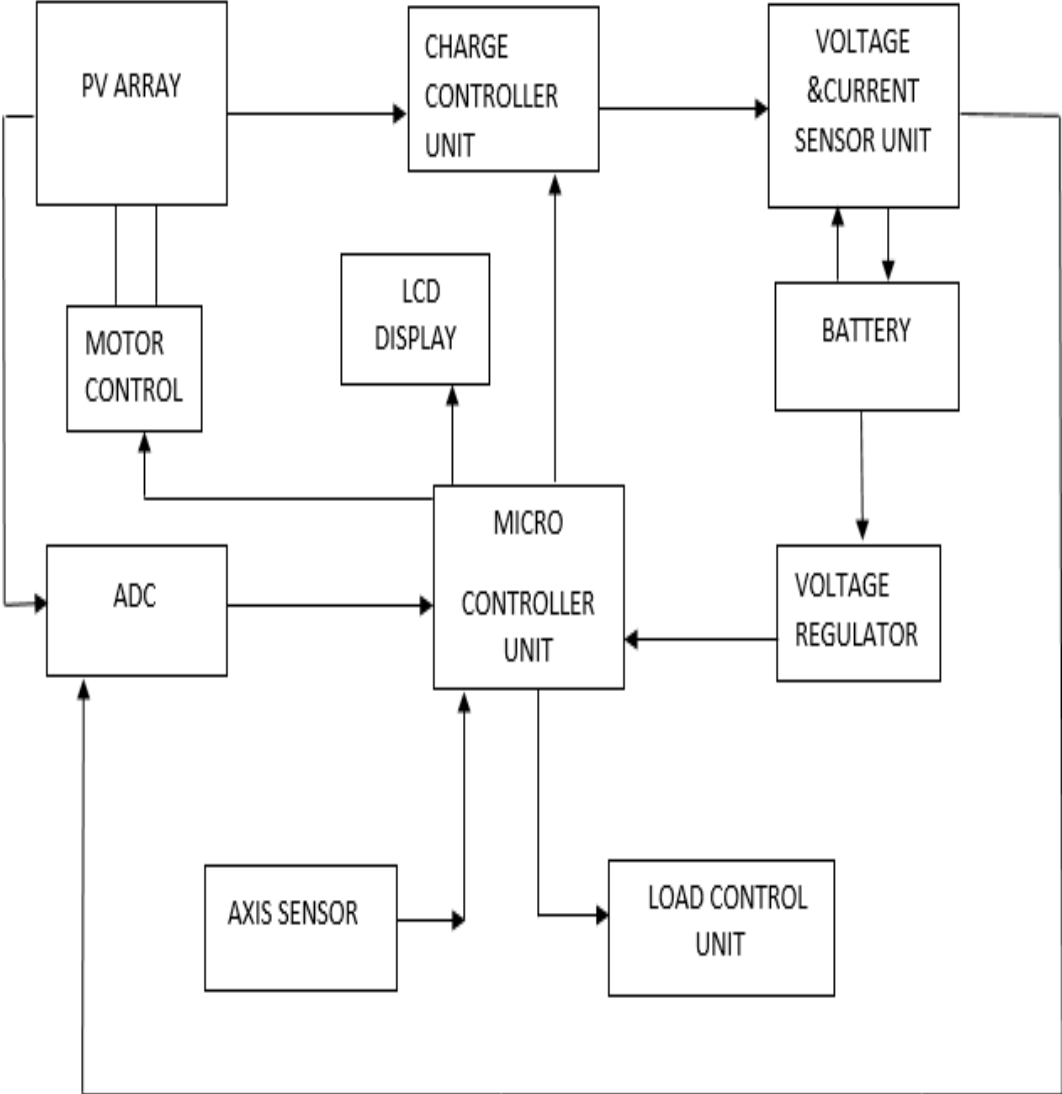

Fig 2.2: Block Diagram of this Project

### 2.5.1 The Model of the Project:

The Proposed model of Dual Axis Solar Tracker System.

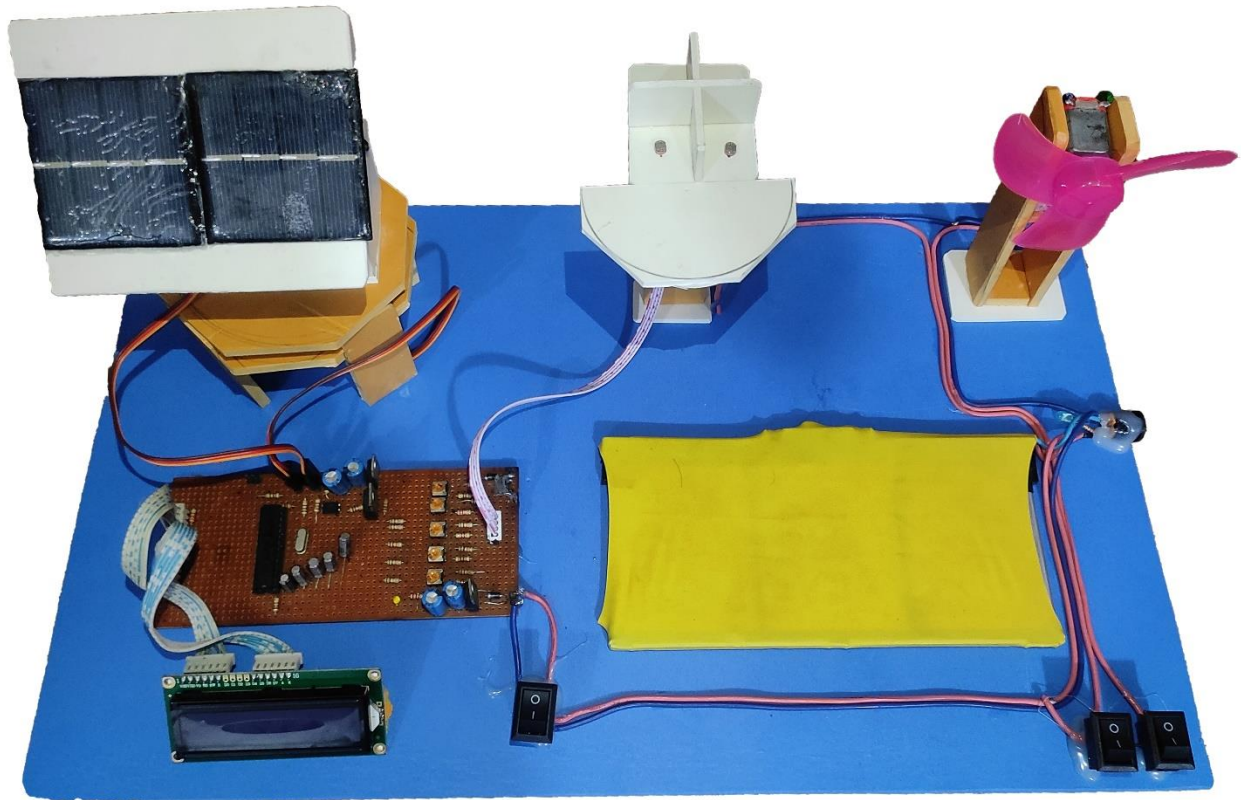

Fig 2.3: Model of this Project

### 2.6 Photovoltaic cell model:

A simplest equivalent circuit of a solar cell is a current source in parallel with a diode. The output of the current source is directly proportional to the solar energy (photons) that hits on the solar cell. During darkness, the solar cell is not an active device; it works as a diode, i.e. A p-n junction. It produces neither a current nor a voltage. The diode determines the IV characteristics of the cell.[3,4]

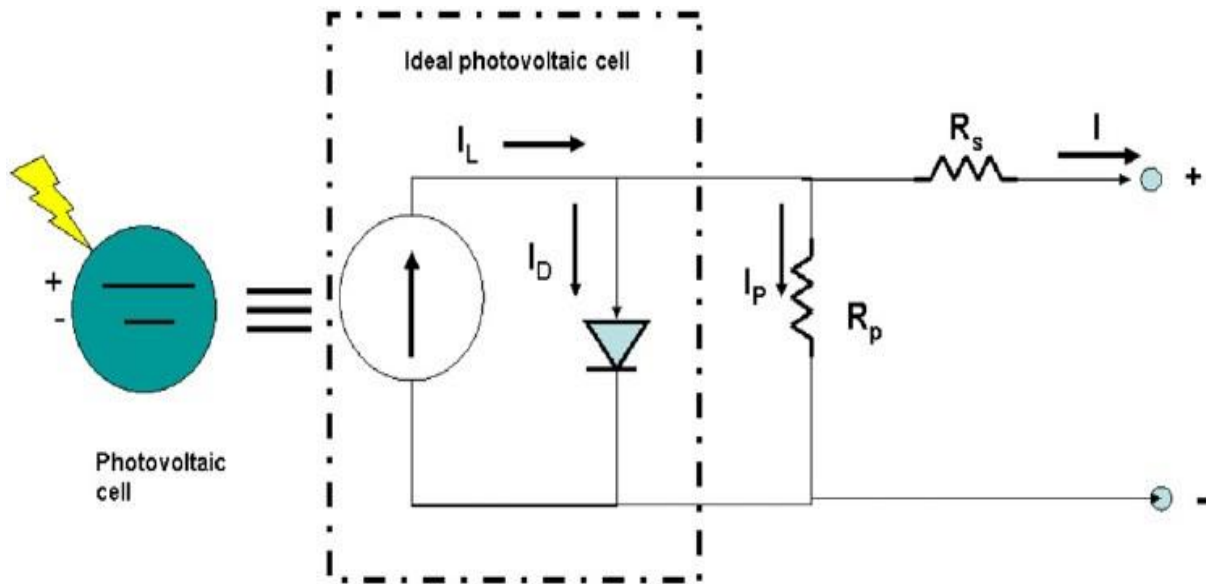

Fig 2.4 Photovoltaic cell block diagram

### 2.6.1 IV curve for a PV cell:

A general I-V characteristic of the solar cell for a given ambient irradiation 'G' and fixed cell temperature 'T' is shown in Fig 3. For a certain resistive load, the load characteristic is a straight line with slope. Power delivered to the load depends on the value of the resistance only. In some cases, if the R load is very small; the PV cell operates in the M-N region of the IV curve, the PV cell act as a constant current source, which is almost equivalent to a short circuit current. However, if the R load is large, the PV cell operates in the P-S region of the IV curve, the PV cell act as a constant voltage source almost equivalent to the open circuit voltage. A PV cell is characterized by the following fundamental parameters in Fig - 2.5.

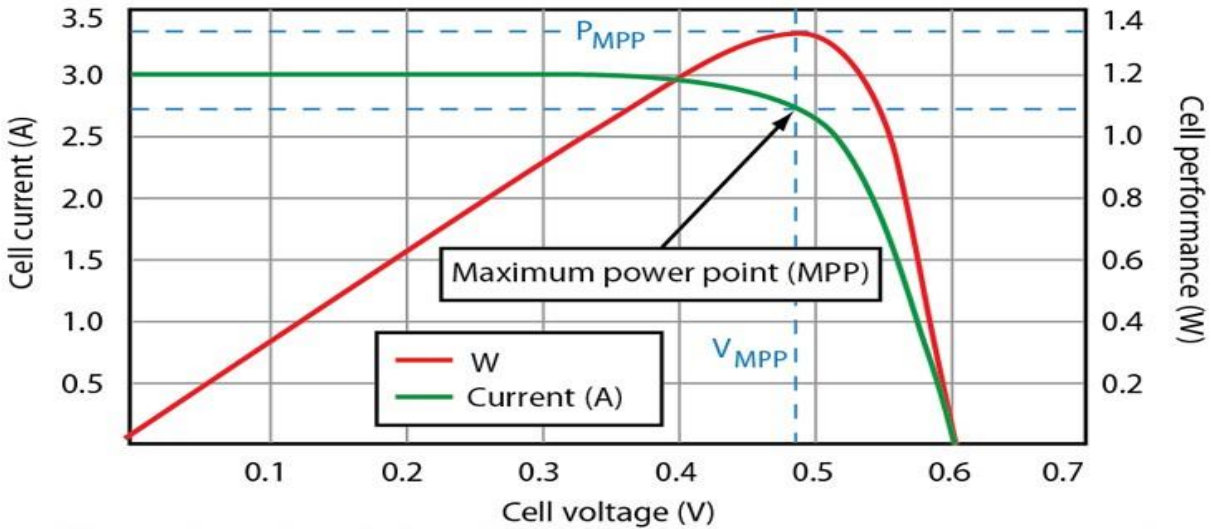

Fig 2.5: Iv Curve of Pv cell

### I/ V Characteristics of PV cell

- Short circuit current:  $I_{sc} = I_{ph}$  (Greatest value of the current generated by a PV cell, which is produced by the short circuit condition:  $V=0$ ).
- Open circuit voltage is a voltage drop across the diode  $D$  when the generated current  $I=0$ . It presumes the voltage of the PV cell in the night and it is expressed by [2].
- Maximum power point is the operating point in Fig 2.3, where the power dissipated in the resistive load is maximum. Maximum efficiency is the ratio of the maximum power and the incident solar energy (photons).  $\eta = P_{max}/P_{in} = V_{max} I_{max}/AG$ . Where  $I$  is the ambient irradiation and  $A$  is the PV cell area.
- Fill factor (FF) is the ratio of the maximum power that can be delivered to the load and the theoretical maximum power which is the product of  $I_{sc}$  and  $V_{oc}$ .  $FF = P_{max}/V_{oc} I_{sc} = V_{max} I_{max}/V_{oc} I_{sc}$ . FF is a measure of real I-V characteristic which value must be higher than 0.7 for a good PV cell. [4,5]

### 2.7 Maximum Power Point Tracking (MPPT):

Maximum Power Point Tracking (MPPT) is an electronic system that operates the Photovoltaic (PV) modules that allows the modules to produce all the power they are capable

of. MPPT is a fully electronic system that varies the electrical operating point of the modules so that the modules are able to deliver maximum available power.

- Let, the values of the current (I) and voltage (V) of the cell result in a maximum power output and a particular load resistance,  $R= V/I$ , as specified by Ohm's Law. The power P is given by  $P = V*I$ . From basic circuit theory, the power delivered
- from or to a device is optimized where the derivative of the I-V curve is equal and
- Opposite of the I/V ratio. This is known as the maximum power point (MPP). The load with resistance  $R=V/I$ , which is equal to the reciprocal of this value and draws
- The maximum power from the device is sometimes called the characteristic resistance of the cell. If the resistance is lower or higher than this value, the power drawn will be less than the maximum available, and thus the cell will not be used as efficiently as it could be. Maximum power point trackers utilize different types of control circuit or logic to search for this point and thus to allow the converter circuit to extract the maximum power available from a cell.[8]

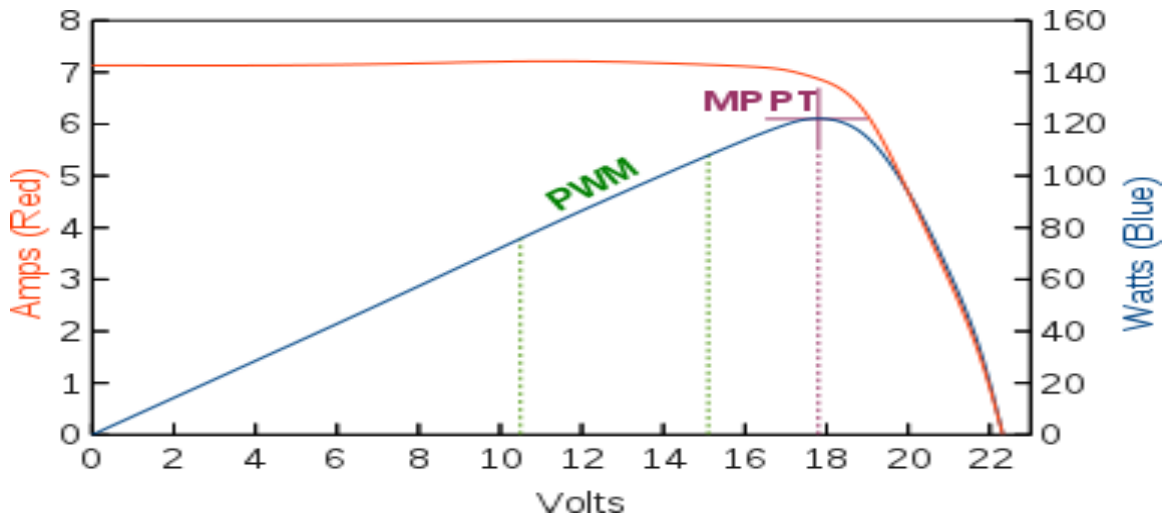

Fig 2.6 maximum power tracking

## 2.8 Solar Irradiation: Sunlight

Electromagnetic radiation means which the sun delivers energy to the earth. The radiation flows evenly distributed from a surface which is close to spherical. The sunlight covers a broad range of wavelengths from roughly 250 nm (UV) over the Visible range (400-700 nm) up to several thousands of nm (IR).

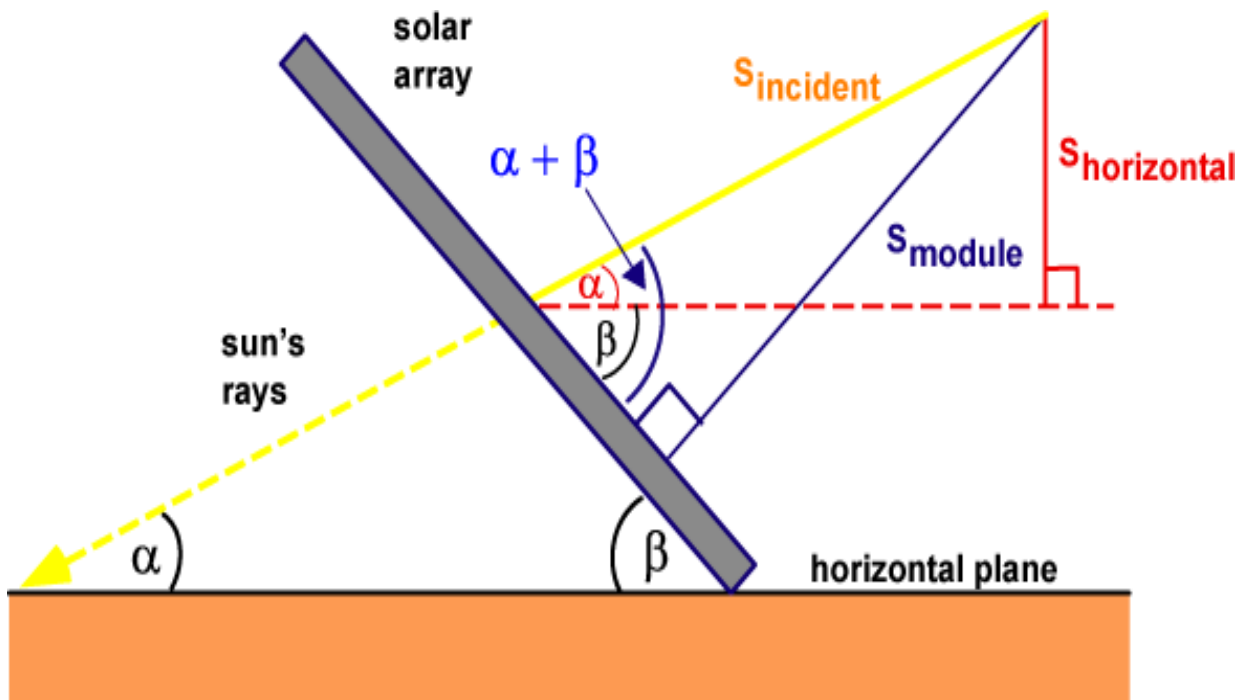

Fig 2.7 Solar Irradiation Sunlight

There is solar fusion that results from the temperature and pressure at the core of the sun. Protons converted into helium atoms at 600 million tons per second. Fusion gives rise to lots of energy in form of gamma rays that are absorbed by particles in the sun and re-emitted. This spectrum contains visible light and near-visible radiation, such as x-rays, ultraviolet radiation, infrared radiation, and radio waves. The visible light and heat of the sun makes life possible, and is called daylight or sunshine. Majority of the sun's harmful radiation deflects by the earth atmosphere. [8,9]

## 2.9 Types of Solar Trackers & System:

Solar Trackers are almost worldily used in case of Solar Thermal Technology because it generates high amounts of energy from sunlight. It's a way to install the pv panel that the sunlight reaches them at perpendicularly or reduce the incidence angle as much as possible. Using tracker on solar panel makes this system smart and the tracker track the sun rays and it's rotated the panel according with rays. There are two types of tracker system and they are single axis solar tracker and dual axis solar tracker.

### 2.9.1 Single axis solar tracker:

Single axis trackers will track the sun from east to west on a single pivot point. With advanced tracking algorithms, it is possible to align them in any cardinal direction. Single axis solar tracker device, on the basis of LDR sensor values, orients the solar panel in accordance with the position of the sun. Average output power of single axis solar tracker is 2.958 w. Average practical efficiency of solar panel for single axis is 6.55%. Average power gain of single axis solar tracker up to 18.32%. [3,4]

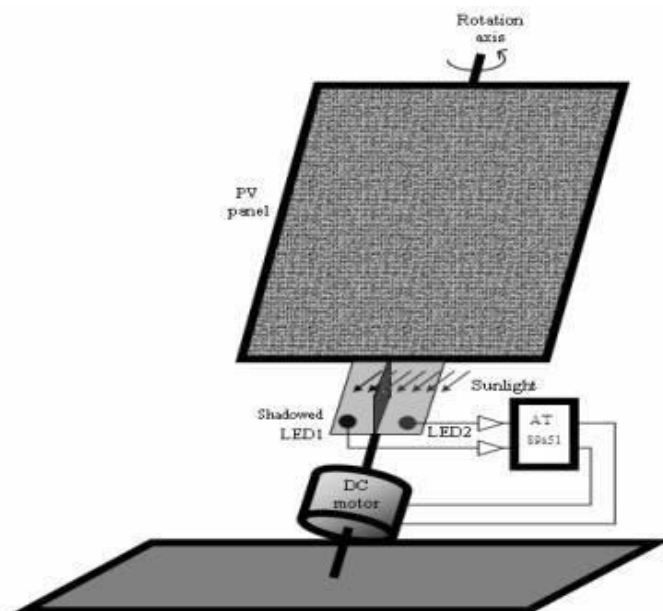

Fig 2.8 Single Axis Solar Tracker

### **2.9.2 Dual axis solar tracker:**

Dual axis tracking system uses the solar panel to track the sun from east to west and north to south. Dual axis solar tracker has two axis of freedom that act as axes of rotation. This axis is fixed with respect to the ground axis consider as a primary axis. But this one is also costly and complicated then single axis solar tracker. Dual axis solar tracker will be reliable and accurate and it is maximizing the output to static and single axis tracking system. This system uses four LDR's, two motors and a controller. The four LDR placed on at four different directions. The controller detects the signal from the LDR's and commands the motor to rotate the panel in respective direction. [3,4]

### **2.9.3 Comparison between single and dual axis solar tracker:**

Individually adjustable solar trackers feature just one degree of flexibility that acts as the tracker's central axis of rotation. This is often oriented along a North-South axis, although it is feasible to align them along any basic axis as well. In general, single-axis solar trackers are less expensive, more reliable, and have a longer lifetime than dual-axis solar trackers; nevertheless, when compared to dual-axis solar trackers, single-axis solar trackers produce less energy under sunny circumstances and have fewer technical advances.

In contrast to single-axis trackers, dual-axis trackers provide two degrees of freedom, allowing for a much greater range of motion. It is via the cooperation of the main and secondary axes that these trackers can direct the solar panels to particular locations in the sky. When compared to single-axis solar trackers, dual-axis trackers provide a greater degree of versatility as well as more precision in directional aiming, allowing them to be more efficient under sunny circumstances overall. [3,4]

### **2.9.4 Effect of the dust density on the inclination of solar panel:**

In general, the Dhaka city climate is weather: dry, hot and dusty at summer, and moderate temperature, little rain, and dusty at winter and maybe dusty along the year. It is known that the accumulation of dust on the solar panels leads to hide the sun radiation from photovoltaic cells, thus tend to decrease the performance of the system. In order to maintain the operation of the system in optimum level, the dust should be cleaned from time to other, the cleaning process can be carried out easily for small systems, but for the large system it will be too difficult process.



The best way to limit this problem, solar panels should fix with a little inclination, at this position wind and rain can help to remove the most amount of the accumulated dust. According to the above explanation, it recommends to place the solar panels at an inclination angle of about 30° to eliminate the effect of this problem [6].

### **2.9.5 Temperature Effect on Solar Panel:**

Temperature has a significant bad effect on the physical properties of silicon photovoltaic cells in terms of instantaneous energy production, and permanent effect. The permanent effect is the reduction of the solar panel service life, where practical experience has shown a decrease in the energy performance of solar panels by 8% after the first year of operation in Iraqi weather, where the cells expose to more than 100 °C. The instantaneous effect has too much reduction of solar panel performance with temperature rise. It is known that the efficiency of photovoltaic cells decreases with the increase of temperature by about 0.4%/°C [13], at the summer the efficiency of the solar panels reduced significantly to 60% of the design capacity, this amount of redaction is always shown on panel label [14].

Therefore, in Iraq weather at summer days the productivity of solar panels is less than panels productivity at winter, until as know that the intensity of light at summer is greater than at winter, causing a high PV temperature effect.

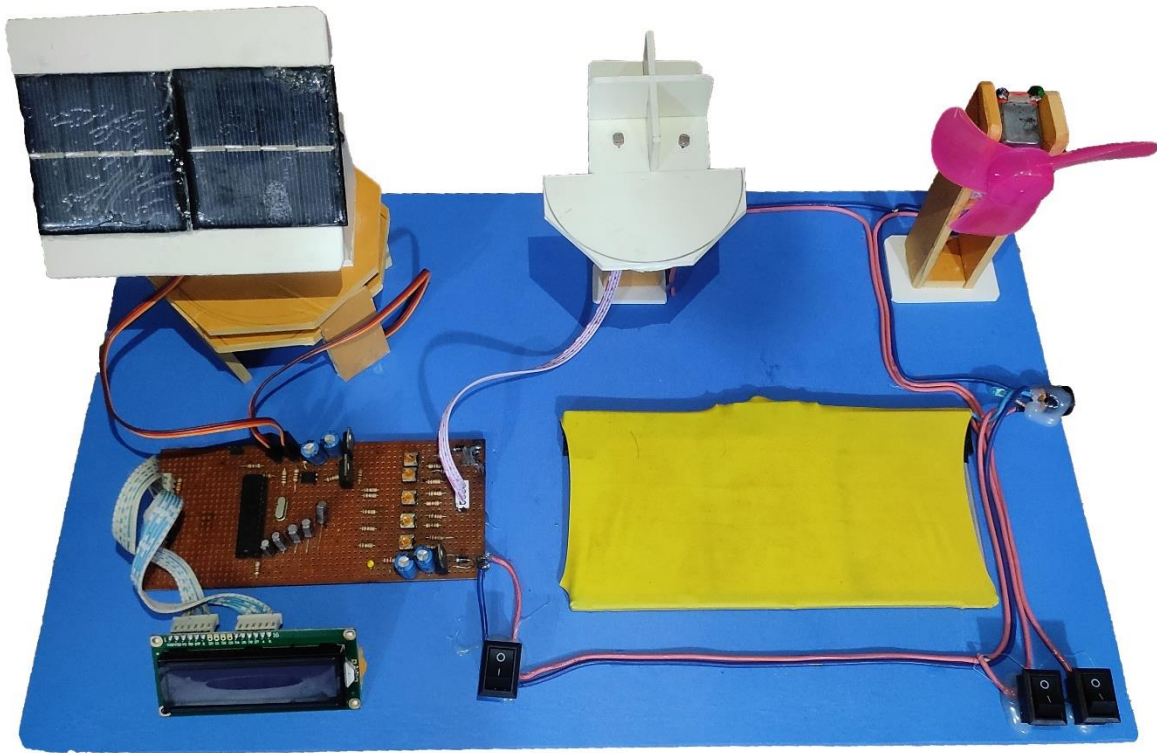

Fig 2.9: Dual axis solar tracking

## 2.10 Efficiency of Solar panel:

The efficiency is the parameter which is most commonly used to compare with one solar panel to another panel. Efficiency is defined as the ratio of energy output from the solar cell to input energy from the sun. The efficiency of a solar cell is determined as the fraction of incident power which is converted to electricity and is defined as:

$$P_{max} = V_{OC} I_{SC} FF$$

$$\eta = \frac{V_{OC} I_{SC} FF}{P_{in}}$$

Where  $V_{oc}$  is the open-circuit voltage;  
where  $I_{sc}$  is the short-circuit current; and  
where  $FF$  is the fill factor  
where  $\eta$  is the efficiency.

The input power for efficiency calculations is  $1 \text{ kW/m}^2$  or  $100 \text{ mW/cm}^2$ . Thus, the input power for a  $100 \times 100 \text{ mm}^2$  cell is  $10 \text{ W}$  and for a  $156 \times 156 \text{ mm}^2$  cell is  $24.3 \text{ W}$ . [7,8]

## **2.11 Advantages & Disadvantages of solar energy:**

There are several benefits that solar energy has and which make it favorable for many uses.

### **2.11.1. Advantages:**

- Solar energy is a clean and renewable energy source.
- It is pollution free.
- Solar cells are free of any noise. On the other hand, various machines used for pumping oil or for power generation are noisy.
- Solar energy can be used in very remote areas where extension of the electricity power grid is costly.
- Once a solar panel is installed, the energy is produced at reduced costs.

### **2.11.2. Disadvantages:**

- Solar power stations do not match the power output of conventional power stations of similar size. Furthermore, they may be expensive to build.
- Generation of electricity from solar is dependent on the country's exposure to sunlight. This means some countries are slightly disadvantaged.

# Chapter 3

## Components, Design & Implementation

### 3.1. LDR (Light Dependent Resistor):

LDR (Light Dependent Resistor) is called as light detecting sensor to build solar track which has included phototransistors, photodiodes and LDR. It is a made up of semiconductor materials which has high resistance. LDR is the most common in electronics and it is spread used in many types of electronics. LDR can use for street lamp, outside lights, a number of indoor home appliances, and so on. It is utilizing the light sensor circuit for automatic switch OFF the loads based on daylight's intensity by helping of a light sensor. In daylight the rays of sun fall on the photovoltaic panel and photo resistor and when the light falls on the resistor, then the resistance changes. This resistor's has different functions and resistance. Using LDR in a circuit or in a electronics project it is make circuiteffective and the collection of LDR parts of the circuit are easily available and accuracy of this circuit is more than accuracy of other circuits. It is so much helpful for saving energy. There are two types of photoresists or based on material used and they are Intrinsic Photo Resistors and Extrinsic Photo Resistors. Intrinsic Photo Resistors are made up of pure semiconductor devices like silicon or germanium. When the light falls on the Intrinsic Photo Resistors, the electrons get excited from the valence band to the conduction band and number of charge carriers increases on a resistor. Extrinsic Photo Resistors are doped with impurities and this impurity creates a new energy band above the valence band.[8]

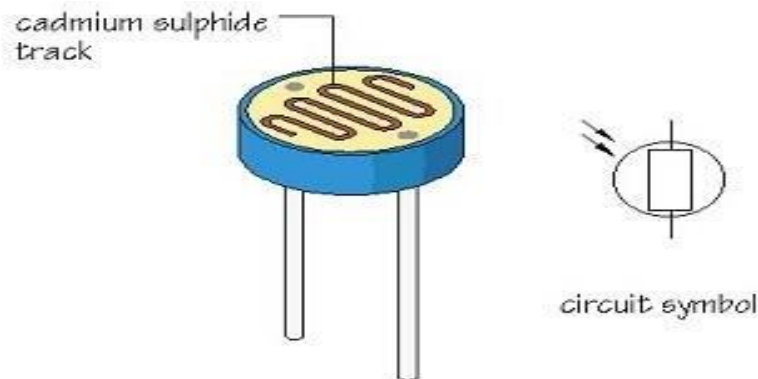

Fig 3.1 Light Dependent Resistor

### 3.1.1. Working Principle of LDR:

Photo Conductivity is the main principle of the light depended resistor. Photo conductivity is an optical method, which the material's conductivity is increased when light is absorbed by the materials. When the light (photon) falls on the materials, the electrons in the valence band of the semiconductor material are excited to the conduction band. These photons in the incident light should have energy greater than the band gap of the semiconductor material to make the electrons jump from the valence band to the conduction band. The result of this process is more and more current starts flowing through the device when the circuit is closed and hence it is said that the resistance of the device has been decreased. This causes the free electrons or holes to conduct electricity and thus dropping the resistance ( $< 1$  Kilo ohm). This is the working principle of light dependent resistor. The equation to show the relation between resistance and illumination can be written as,

$$R = A.E^a$$

Where E – Illumination (lux)

R – Resistance (Ohms)

A, a – constants

The value of 'a' depends on the CdS used and on the manufacturing process. Values usually range between 0.7 and 0.9.

### 3.1.2 The Design and implementation of using Four LDRs:

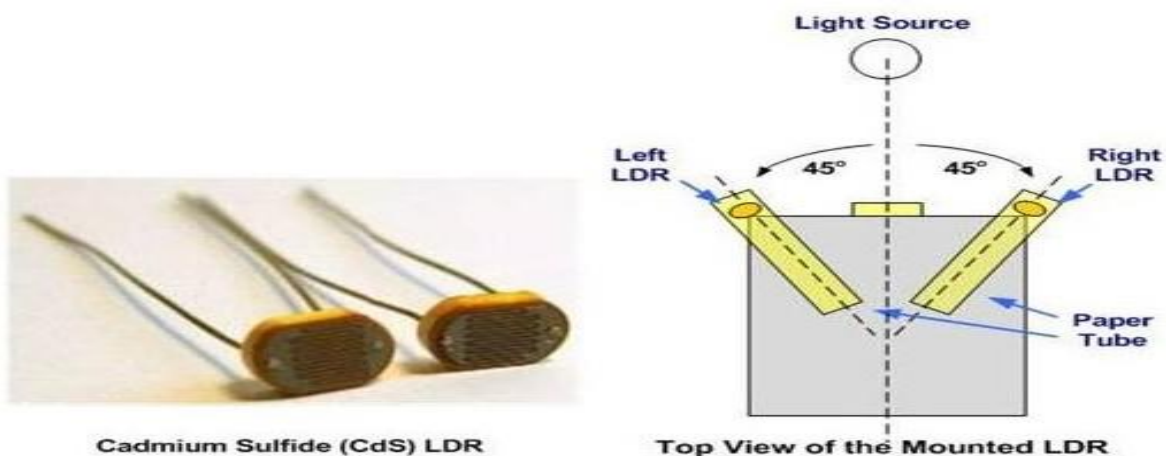

Fig 3.2 quadrant wise LDR positioning

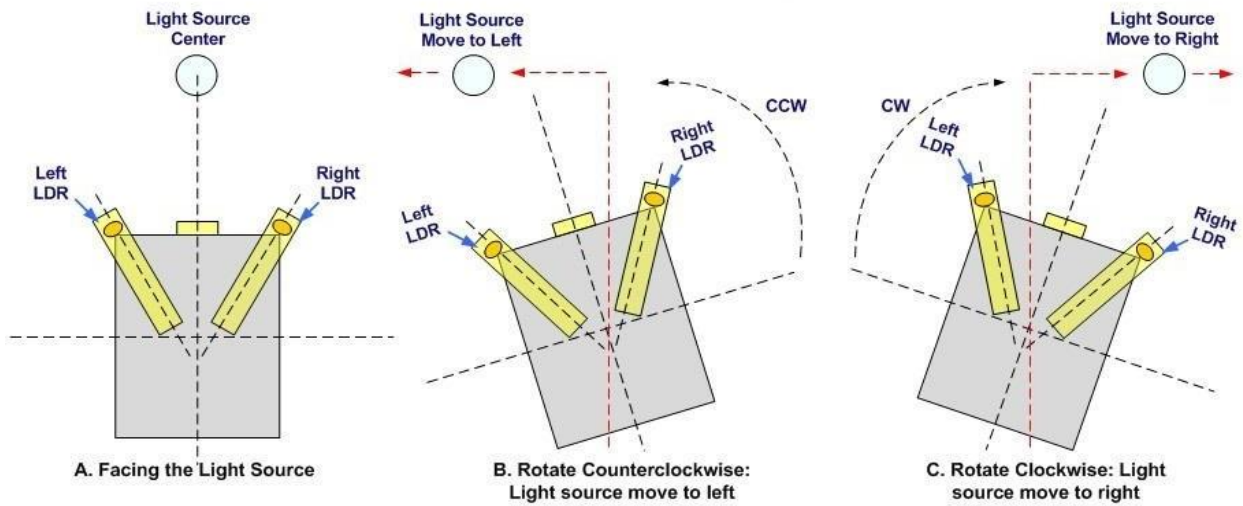

Fig 3.3 the Sensing Element and Signal Processing

There are several methods was proposed and used to track the position of sun light. We used four LDRs to track our module properly. A Light Dependent Resistor separated by a small plate to act as a shield to sunlight, as shown in the next figures. The two LDRs are connected to a bridge and the output of the bridge is connected to a comparator (the analog comparator of the microcontroller is used).

When LDR1 has higher light intensity than LDR2 then the resistance of LDR1 is smaller than that of LDR2 then voltage at AIN0 is higher than that of AIN1 and the output of comparator is high.

When LDR2 has higher light intensity than LDR1 then the resistance of LDR1 is larger than that of LDR2 then voltage at AIN0 is smaller than that of AIN1 and the output of comparator is low. Then the output of the comparator is used in the UC program to control the stepper motor RV1 variable resistor is used to balance the bridge when the two LDRs having the same light intensities (due to the mismatch between the two LDRs).

Similarly, we used the process for Ldr3 and LDR4 using Dark and Bright Fringes.

### 3.1.3 The minimum light detectable Equation:

It's a circuit used to detect the condition when there is no sunlight to turn off the tracking system

It uses a summing op. amp. Circuit its output is given by,

$$V_{AIN0} + V_{AIN1} - 5 \left( \frac{RV2}{RV2 + R6} \right) = 1.23 V$$

Where 1.23V is the internal band gap reference used by the analog comparator in the UC.

By calculating the value of V (AIN0) and V (AIN1) at sunset and adjusting RV2 the output of the comparator can be used to turn on or turn off the solar tracking system.[9]

### 3.2 LCD (2 Line 16 Carriers):

LCD (Liquid Crystal Display) screen is an electronic display module. A 16x2 LCD display is very basic module and is very commonly used in various devices and circuits. These modules are preferred over seven segments and other multi segment LEDs. The reasons being: LCDs are economical; easily programmable; have no limitation of displaying special & even custom characters (unlike in seven segments), animations and so on.



Fig 3.4 LCD

A **16x2 LCD** means it can display 16 characters per line and there are 2 such lines. In this LCD each character is displayed in 5x7 pixel matrix. This LCD has two registers, namely, Command and Data. A register which commanded storage the command instructions to the given LCD like initializing it, clearing its screen, setting the cursor position, controlling display etc. The data register stores the data to be displayed on the LCD.

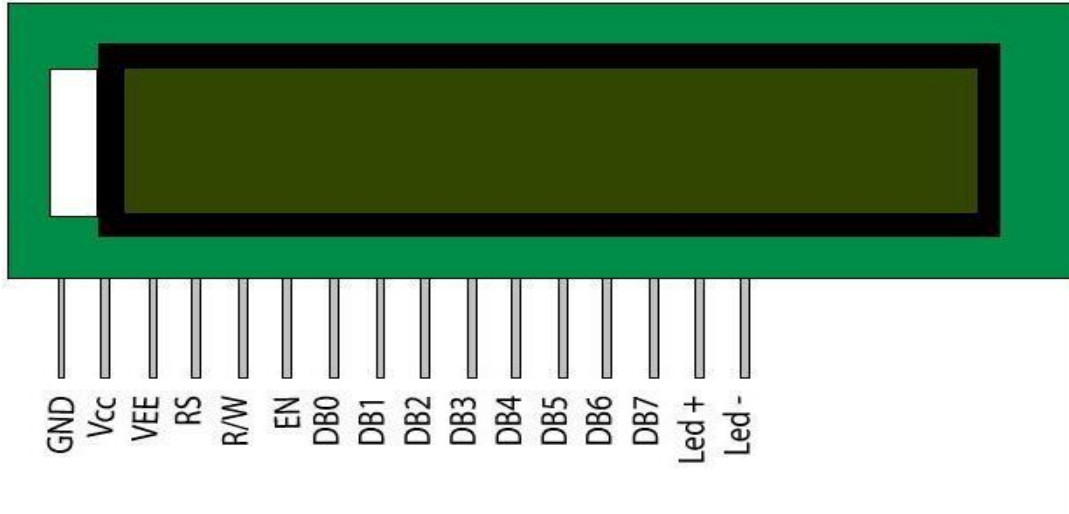

Fig 3.5 LCD (2\*16) Pin

### 3.2.1. Pin Features:

- 5\*8 Dots with cursor
- 16 Characters \*2-line display
- 4-bit or 8-bit MPU interfaces
- Display mode & Backlight Variations
- ROHS Compliant

### 3.2.2 Pin Description:

16 pin LCD description given bellow:

Pin No	Function	Name
1	Ground (0V)	Ground
2	Supply voltage; 5V (4.7V – 5.3V)	Vcc
3	Contrast adjustment; through a variable resistor	V <sub>EE</sub>
4	Selects command register when low; and data register when high	Register Select
5	Low to write to the register; High to read from the register	Read/write
6	Sends data to data pins when a high to low pulse is given	Enable
7	8-bit data pins	DB0
8		DB1
9		DB2
10		DB3
11		DB4
12		DB5
13		DB6
14		DB7
15	Backlight V <sub>CC</sub> (5V)	Led+
16	Backlight Ground (0V)	Led-



### 3.3 Servo Motor:

Servo motor is a self-contained electric devices and simple electrical motor, which is controlled with the help of servomechanism. It is a motor which has a output shaft and can be moved to a specific angular position by sending it a coded signal. The servo motor will maintain the position of the shaft . When we changed the coded signal, the angular position of the shaft will change. Servo motors are used for various applications. They are normally small in size and have good energy efficiency. The cost of this motor also less than others motors and also simple to used. Servos are found in many places from toys to home electronics to cars and airplanes. Servos also appear behind the scenes in devices we use every day.

Servo motor also used in robotic projects for every moving of their joint. The servo circuitry is built inside the motor unit and comes with a position able shaft that is fitted with a gear.



Fig :3.6 Standard Servo Motor SG-90

The motor is controlled with an electric signal that determines the amount of shaft movement. In a market there are found two types of servo motor, one is made up of metal gear and another are made up of plastic gear. The metallic one is much heavier than other gear one. The size of metallic gear servo motor is also bigger than plastic gear servo motor.

### 3.3.1. Components of servo motor SG-90

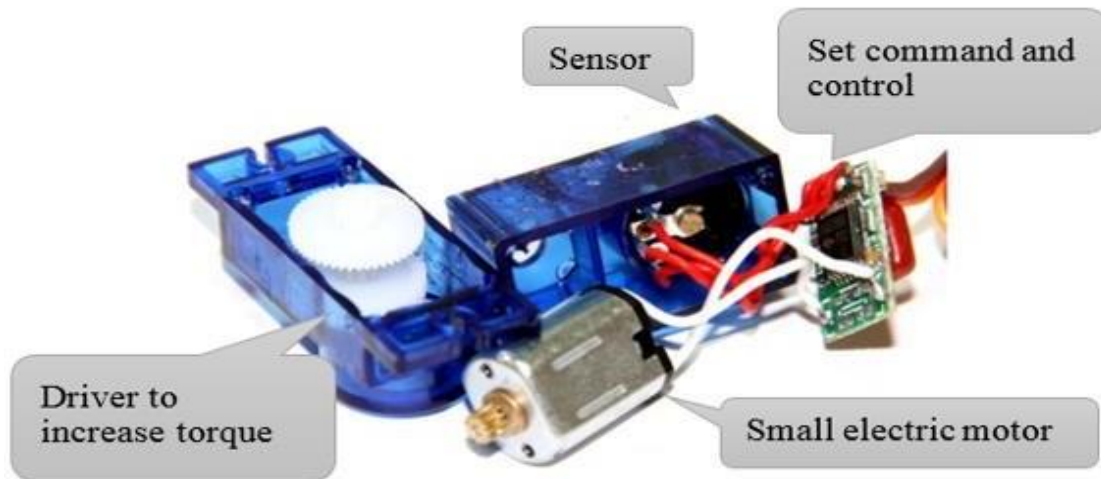

Fig 3.7 Physical Construction of Servo SG-90

In our work we used SERVO MOTOR SG90 and it's easy to use because it is small in size which makes our work comfortable. In briefly below we discussed on SG90.

**SERVO MOTOR SG-90:** It is tiny and lightweight with high output power. This servo can rotate approximately 180 degrees and it works just like the standard kinds

#### Specifications:

- Weight: 9 gm
- Dimension: 22.2 x 11.8 x 31 mm approx.
- Stall torque: 1.8 kgf cm
- Operating speed: 0.1 s/60 degree
- Operating voltage: 4.8 V (~5V)
- Dead band width: 10  $\mu$ s
- Temperature range: 0 °C – 55 °C

### **3.3.2. Servo Mechanism:**

A servo system mainly consists of three basic components - a controlled device, an output sensor, a feedback system. This is an automatic closed loop control system. Here instead of controlling a device by applying variable input signal, the device is controlled by a feedback signal generated by comparing output signal and reference input signal. When reference input signal or command signal is applied to the system, it is compared with output reference signal of the system produced by output sensor, and a third signal produced by feedback system. This third signal acts as input signal of controlled device. This input signal to the device presents as long as there is a logical difference between reference input signal and output signal of the system. After the device achieves its desired output, there will be no longer logical difference between reference input signal and reference output signal of the system. Then, third signal produced by comparing these above said signals will not remain enough to operate the device further and to produce further output of the system until the next reference input signal or command signal is applied to the system.

### **3.3.3. Working Principle of Servo Motor:**

A servo motor is basically a DC motor (in some special cases it is AC motor) along with some other special purpose components that make a DC motor a servo. In a servo unit, you will find a small DC motor, a potentiometer, gear arrangement and an intelligent circuitry. The intelligent circuitry along with the potentiometer makes the servo to rotate according to our wishes.

As we know, a small DC motor will rotate with high speed but the torque generated by its rotation will not be enough to move even a light load. This is where the gear system inside a servo mechanism comes into picture. The gear mechanism will take high input speed of the motor (fast) and at the output; we will get an output speed which is slower than original input speed but more practical and widely applicable.

Say at initial position of servo motor shaft, the position of the potentiometer knob is such that there is no electrical signal generated at the output port of the potentiometer . This output port of the potentiometer is connected with one of the input terminals of the error detector amplifier. Now an electrical signal is given to another input terminal of the error detector amplifier. Now difference between these two signals, one comes from potentiometer and another comes from external source,

will be amplified in the error detector amplifier and feeds the DC motor. This amplified error signal acts as the input power of the dc motor and the motor starts rotating in [1] desired direction. As the motor shaft progresses the potentiometer knob also rotates as it is coupled with motor shaft with help of gear arrangement. As the position of the potentiometer knob changes there will be an electrical signal produced at the potentiometer port. As the angular position of the potentiometer knob progresses the output or feedback signal increases. After desired angular position of motor shaft the potentiometer knob is reaches at such position the electrical signal generated in the potentiometer becomes same as of external electrical signal given to amplifier. At this condition, there will be no output signal from the amplifier to the motor input as there is no difference between external applied signal and the signal generated at potentiometer . As the input signal to the motor is nil at that position, the motor stops rotating. This is how a simple conceptual servo motor works.

#### **3.3.4. Servo Motor Control:**

Let us consider an example of servomotor that we have given a signal to rotate by an angle of  $45^\circ$  and then stop and wait for further instruction.

The shaft of the DC motor is coupled with another shaft called output shaft, with help of gear assembly. This gear assembly is used to step down the high rpm of the motor's shaft to low rpm at output shaft of the servo system.

The voltage adjusting knob of a potentiometer is so arranged with the output shaft by means of another gear assembly, that during rotation of the shaft, the knob also rotates and creates an varying electrical potential according to the principle of potentiometer . This signal i.e. electrical potential is increased with angular movement of potentiometer knob along with the system shaft from  $0^\circ$  to  $45^\circ$ . This electrical potential or voltage is taken to the error detector feedback amplifier along with the input reference commends i.e. input signal voltage.

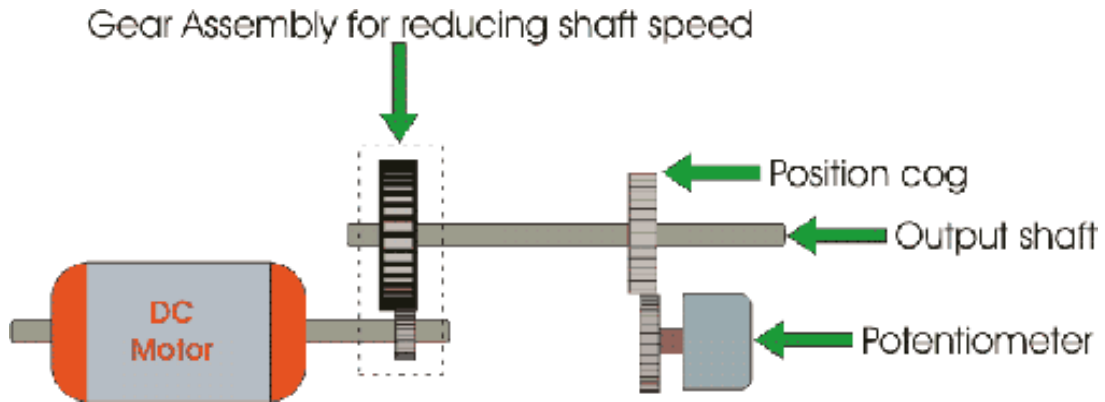

Fig 3.8 Servo Gear assembly

As the angle of rotation of the shaft increases from  $0^\circ$  to  $45^\circ$  the voltage from potentiometer increases. At  $45^\circ$  this voltage reaches to a value which is equal to the given input command voltage to the system. As at this position of the shaft, there is no difference between the signal voltage coming from the potentiometer and reference input voltage (command signal) to the system, the output voltage of the amplifier becomes zero.

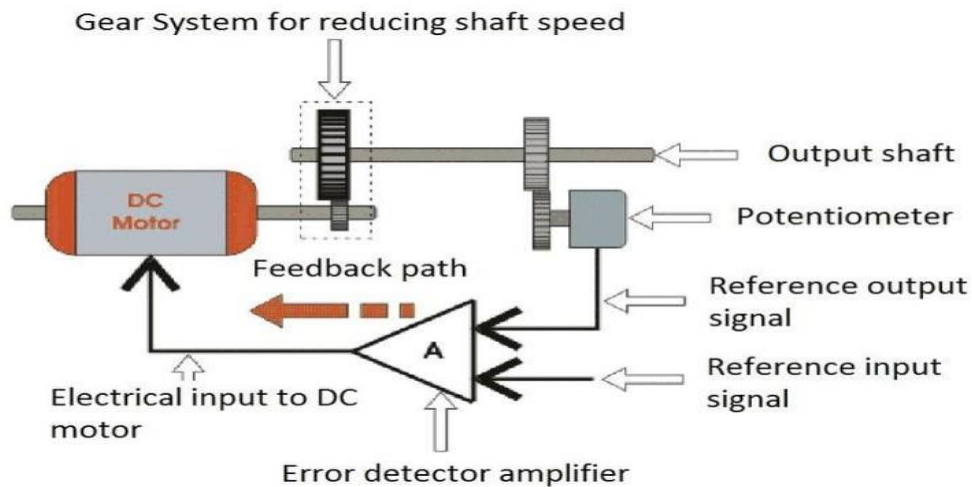

Fig 3.9 inside look of Servo motor

As per the picture given above the output electrical voltage signal of the amplifier, acts as input voltage of the DC motor. Hence the motor will stop rotating after the shaft rotates by  $45^\circ$ . The motor will be at this rest position until another command is given to the system for further movement of the shaft in desired direction. From this example we can understand the most basic **servo motor theory** and how **servo motor control** is achieved. [8,9,10]

### **Advantages & Disadvantages of using Servo motor:**

There are some advantages and disadvantages of using servo motor. In below we discussed about advantages and disadvantages of servo motor.

#### **Advantages:**

- Servo motors are the better option for high speed and high torque.
- Servo motors are available at much faster speed.
- Servo motors are accurate positioning.
- Servo motors also maintain torque at high speed, up to 90%.
- Servo has efficiency of about 80-90%.
- Servo motors are small is size.
- Servo motor has a resonance and vibration free operation.

#### **Disadvantages:**

- Servo motors are expensive to buy.
- Servo motors have required setup to stabilize feedback loop. Servo motor can be damagedfor overloading.
- Servo motor has poor motor cooling. Servo motor design more mechanically complex.
- Servo motor maintenance requirements will also increase.

### **3.4. Microcontroller:**

A microcontroller is a single chip micro-computer on a single integrated circuit containing a processor core, memory, and programmable input/output peripherals. Basically, microcontrollers are used in automatically controlled products and devices, such as automobile engine control systems, implantable medical devices, remote controls, office machines, appliances, power tools, toys and other embedded systems. A microcontroller is available in different word lengths like

microprocessors (4bit,8bit,16bit,32bit,64bit and 128-bit microcontrollers are available today). Here we use PIC16F877A microcontrollers.



Fig: 3.10 PIC16F877A Microcontroller

**A microcontroller contains one or more of the following components:**

- Central processing unit (CPU)
- Random Access Memory (RAM)
- Read Only Memory (ROM)
- Input/output ports
- Timers and Counters
- Interrupt controls
- Analog to digital converters
- Digital analog converters
- Serial interfacing ports

**Basic Block Diagram of Microcontroller:**

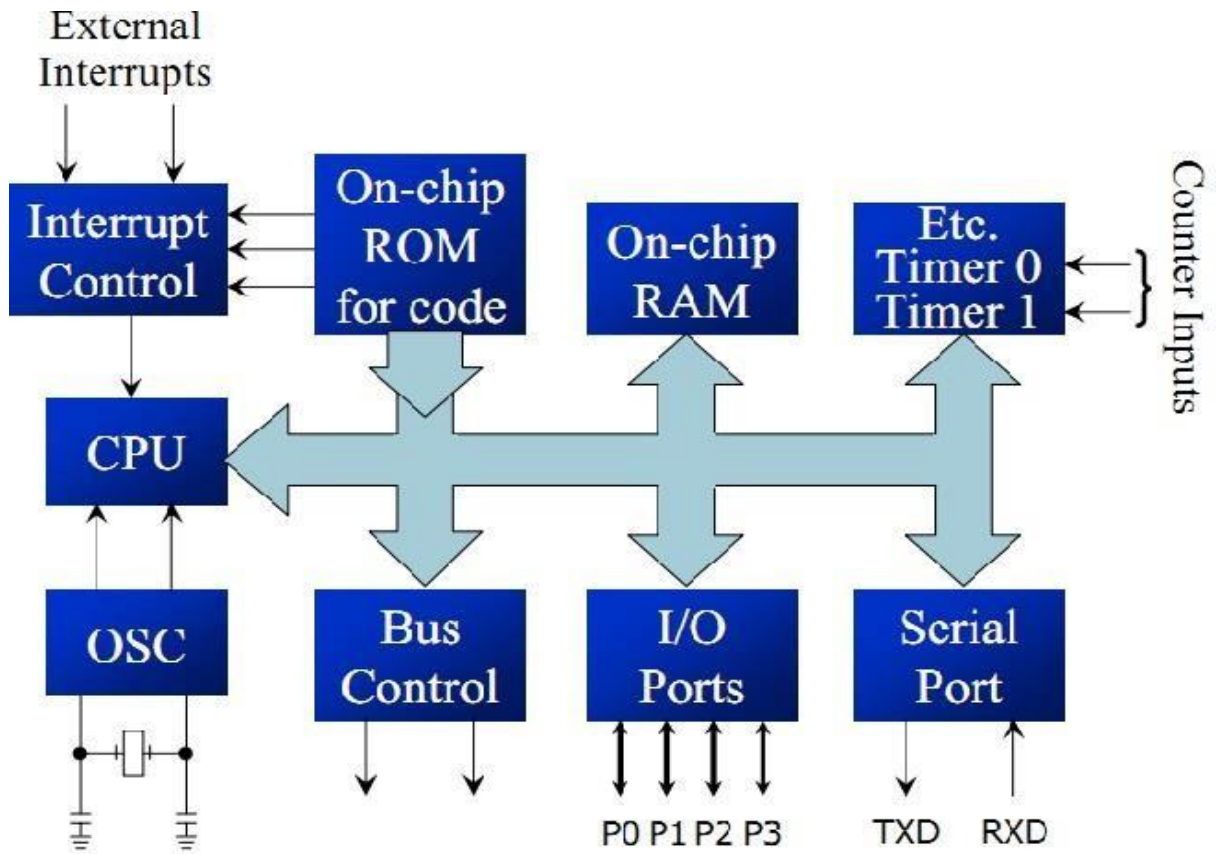

Fig 3.11 Basic Block Diagram of Microcontroller



### 3.4.1 PIC16F877 Pin Diagram:

The 16F877A is one of the most popular and advanced microcontrollers from Microchip and it is easy to implement in a circuit. The 40 pins make it easier to use the peripherals as the functions are spread out over the pins. This controller is widely used for experimental cause its application range is wide, high quality, ease of availability and low cost.[11]

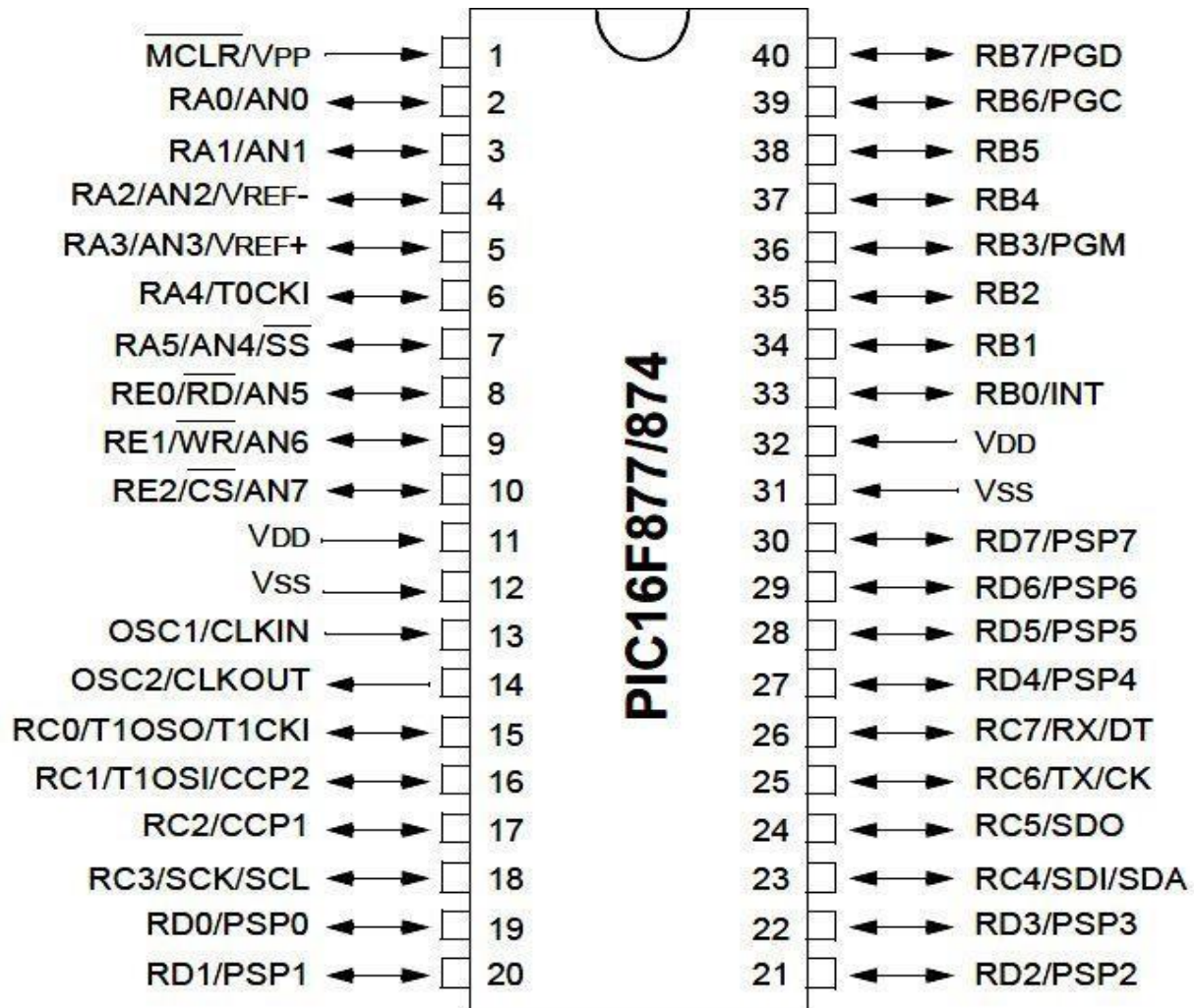

Fig: 3.12 PIC16F877 Microcontrollers

### 3.4.2. Block Diagram of PIC16F877A: [11,12]

The Block Diagram of PIC16F877 has given below:

Device	Program FLASH	Data Memory	Data EEPROM
PIC16F874	4K	192 Bytes	128 Bytes
PIC16F877	8K	368 Bytes	256 Bytes

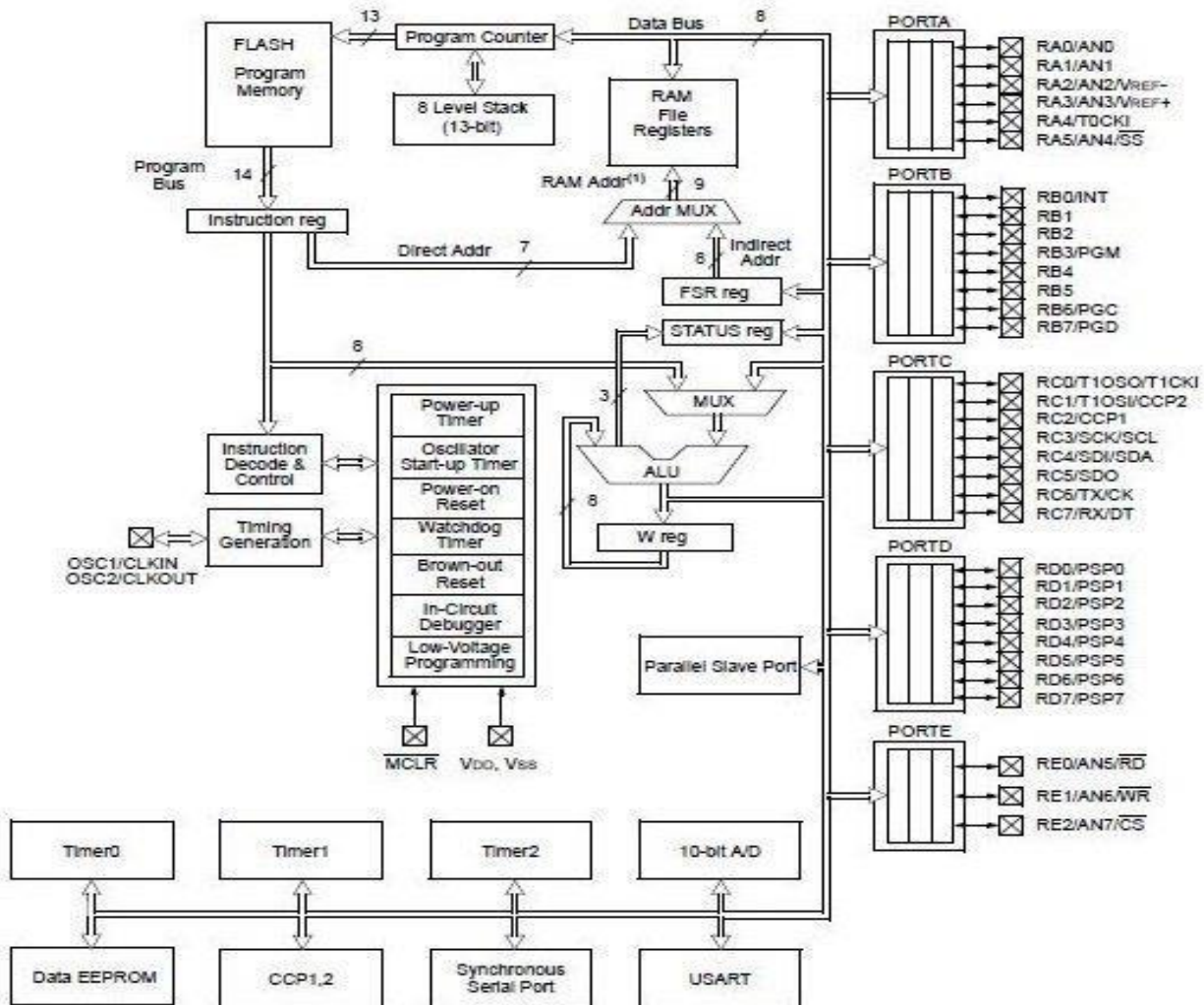

Fig :3.13 Block Diagram of PIC16F877A

### 3.4.3. Pin and their functions:

Pin Number	Description Function
1	MCLR/VPP - Master Clear Input
2	RA0/AN0 - Port A
3	RA1/AN1 - Port A
4	RA2/AN2/VREF-/CVREF - Port A
5	RA3/AN3/VREF+ - Port A
6	RA4/T0CKI/C1OUT - Port A
7	RA5/AN4/SS/C2OUT - Port A
8	RE0/RD/AN5 - Port E
9	RE1/WR/AN6 - Port E
10	RE2/CS/AN7 - Port E
11	Vdd - Positive Power Supply
12	Vss - Ground
13	OSC1/CLKI - Oscillator Input
14	OSC2/CLKO - Oscillator Output
15	RC0/T1OSO/T1CKI - Port C
16	RC1/T1OSI/CCP2 - Port C
17	RC2/CCP1 - Port C
18	RC3/SCK/SCL - Port C
19	RD0/PSP0 - Port D
20	RD1/PSP1 - Port D
21	RD2/PSP2 - Port D
22	RD3/PSP3 - Port D
23	RC4/SDI/SDA - Port C
24	RC5/SDO - Port C
25	RC6/TX/CK - Port C
26	RC7/RX/DT - Port C
27	RD4/PSP4 - Port D

28	RD5/PSP5 - Port D
29	RD6/PSP6 - Port D
30	RD7/PSP7 - Port D
31	Vss - Ground
32	Vdd - Positive Power Supply

### **3.4.4. The Features of PIC16F877:**

There are various features that make the PIC16F877 a good choice for the project:

#### High-Performance RISC CPU

- Only 35 single word instructions to learn
- All instructions are single cycle (1 $\mu$ s) except for program branches
- Operating speed: DC - 20MHz clock input
- 8 Kbytes Flash Program Memory
- 368 Byte RAM Data Memory
- 256 Byte EEPROM Data Memory
- In-circuit Serial Programming

#### Peripheral Features

- Two 8-bit timer/counter (TMR0, TMR2) with 8-bit programmable presale
- One 16-bit timer/counter (TMR1)
- High current source/sink for direct LED drive
- Watchdog Timer (WDT) with Separate RC Oscillator
- Two Capture, Compare, PWM Modules
- Synchronous Serial Port with SPI and I<sup>2</sup>C
- Universal Synchronous Asynchronous Receiver Transmitter (USART)

#### Special Microcontroller Features

- Power-On Reset
- Power-up Timer (PWRT) and Oscillator Start-Up Timer (OST)
- 1,000 erase/write cycles Enhanced Flash Program Memory

- 1,000,000 typical erase/write cycles EEPROM Data Memory
- Selectable Oscillator Options

#### CMOS Technology

- Low power, high speed CMOS FLASH technology
- Fully Static Design
- Low Power Consumption

#### I/O and Packages

- 33 I/O pins with individual direction control
- 40-pin DIP

### 3.4.5. PIC16F877 Development Board:

The immensely popular PIC16F877 development board for the PIC16F877 enables easy development and testing of various solutions. PIC16F877 is already included together with power supply components and crystals.

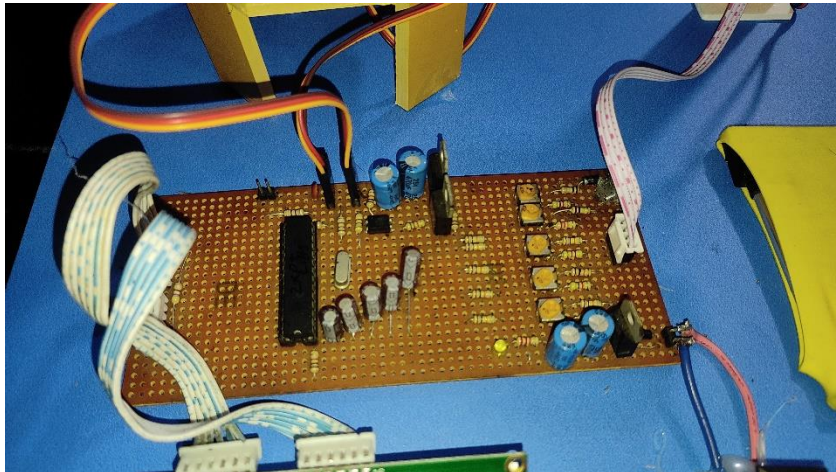

Fig: 3.14 Pic16F877 development board

### 3.5. Voltage regulator:

A voltage regulator generates a fixed output voltage of changes to its input voltage or load conditions. The voltage regulator must be stable with its condition. Here we use IC 7805 voltage Regulator. IC

7805 is a 5V Voltage Regulator that restricts the voltage output to 5V and draws 5V regulated power supply. The voltage source in a circuit may have fluctuations and would not give the fixed voltage output. The voltage regulator IC maintains the output voltage at a constant value.

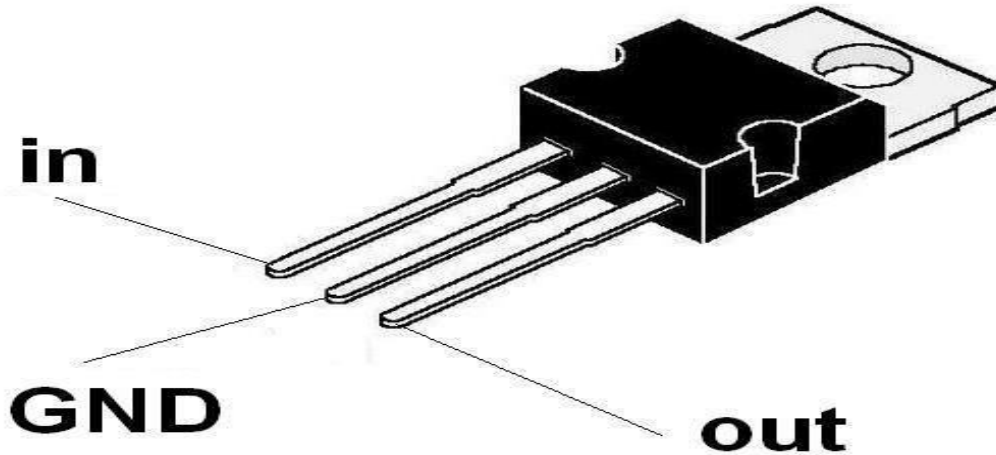

Fig 3.15 Voltage Regulator

IC 7805 is a 5V Voltage Regulator that restricts the voltage output to 5V and draws 5V regulated power supply. It comes with provision to add heat sink. The maximum value for input to the voltage regulator is 35V. It can provide a fixed steady voltage flow of 5V for higher voltage input till the threshold limit of 35V. If the voltage is near to 7.5V then it does not produce any heat and hence no need for heat sink. If the voltage input is more, then excess electricity is liberated as heat from 7805. It regulates a steady output of 5V if the input voltage is in range of 7.2V to 35V. Hence to avoid power loss try to maintain the input to 7.2V. In some circuitry voltage fluctuation is fatal (for e.g. Microcontroller), for such situation to ensure constant voltage IC 7805 Voltage Regulator is used. IC 7805 is a series of 78XX voltage regulators. The name the last two digits 05 denotes the amount of voltage that it regulates. Hence a 7805 would regulate 5v and 7806 would regulate 6V and so on. The schematic given below shows how to use a 7805 IC, there are 3 pins in IC 7805, pin 1 takes the input voltage, GND of both input and out are given to pin 2, pin 3 produces the output voltage.

### 3.5.1. Pin Description:

Pin no.	Function	Name
1	Input voltage (5V-18V)	Input
2	Ground (0V)	Ground
3	Regulated output; 5V (4.8V-5.2V)	Output

### 3.6. Capacitor:

Capacitor is an essential component of our project. We can use the capacitor in different many applications. Using capacitor in a microcontroller its must because of the microcontroller is a digital device with fast switching edges which uses a large amount of current for a very short period of time at each transition. The capacitors supply the large amount of current needed so that the power supply doesn't sag during that time creating noise. The main function of a capacitor is storing electric charge. A charged capacitor could be used as a voltage source. It is always best to use a variety of capacitors on the power supply pins of the microcontroller to provide a low impedance wideband supply. In our work we used variable value of capacitors and they are 10  $\mu$ F (6 Pcs) & 100 $\mu$ F (1Pc). Capacitors are used for several purposes like timing, smoothing power supply, coupling, filtering, tuning for radio system, storing energy etc.



Fig 3.16 100 $\mu$ F & 10 $\mu$ F Capacitor



### 3.7. 606-Transformer:

6-0-6 it's a good quality transformer, power supplies for all kinds of project & circuit boards. It is step down 230V AC to 6V with a maximum of 200mA current. We used this transformer to get AC current and which converted to DC current with a help of converter.



Fig :3.17, 606-Transformer

#### Soldering wire:

Solder is basically metal wire with a "low" melting point, where low for our purposes means low enough to be melted with a soldering iron. For electronics, it is traditionally a mix of tin and lead. When the soldering wire cooled off an electrical connection will conduct. This is getting a good mechanical connection between the wires. The filaments of each wire should be twisted together, behave more like a single entity. First step is to prepare the wires then tinning the wears, next to join the wires and solder splice together.



Fig 3.18 Soldering two wires

### 3.8 CCS C Compiler:

CCS stands for Custom Computer Services, a Microchip PIC Microcontroller Tool Solutions company. CCS C are the best compilers for beginners as they includes a lot of built in libraries which enable us to program a PIC Microcontroller without the deep knowledge of its internal architecture. I think CCS C is the best High Level Language Compiler for PIC Microcontroller as it is almost hardware independent.

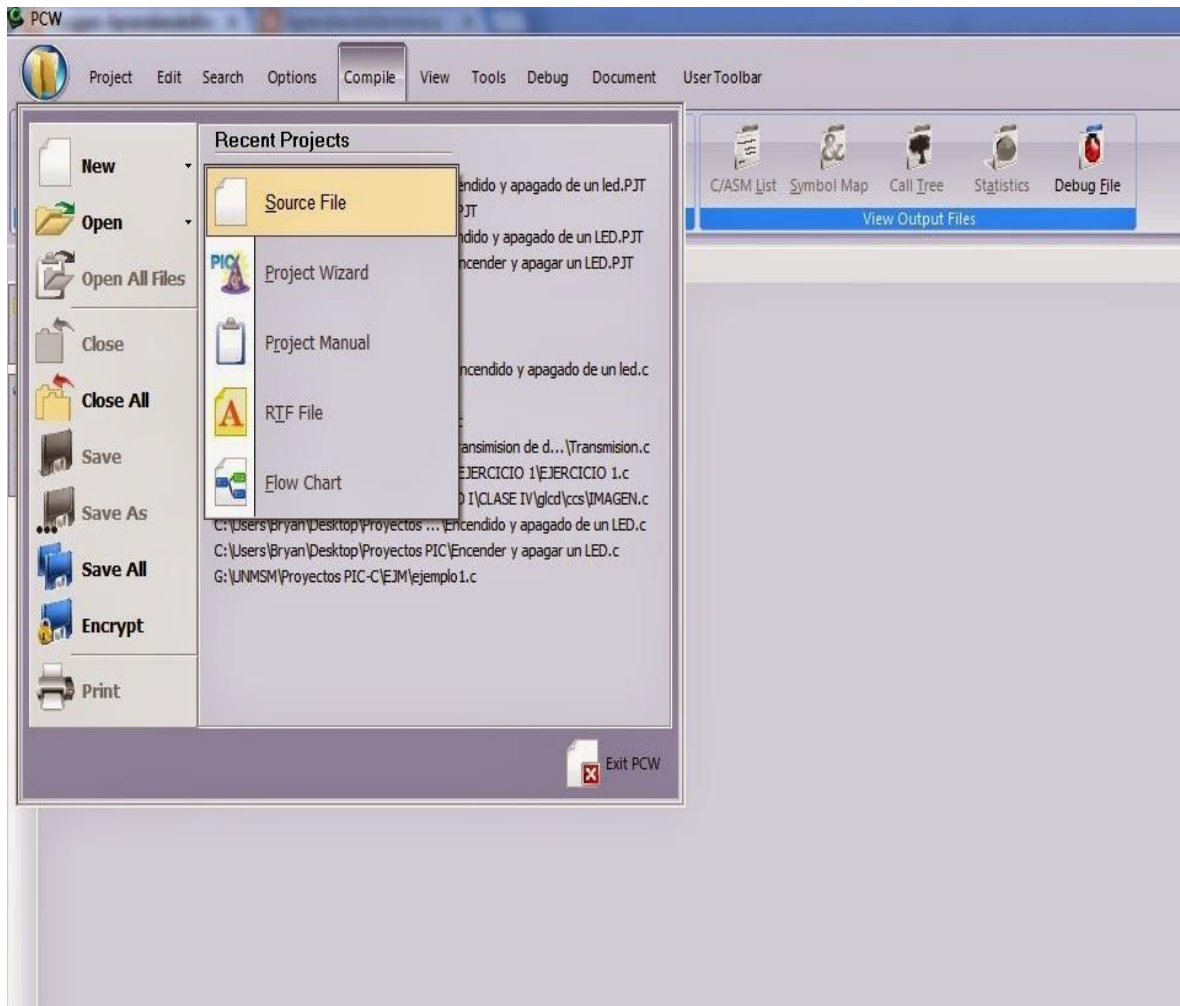

Fig: 3.19 CCS C Compiler

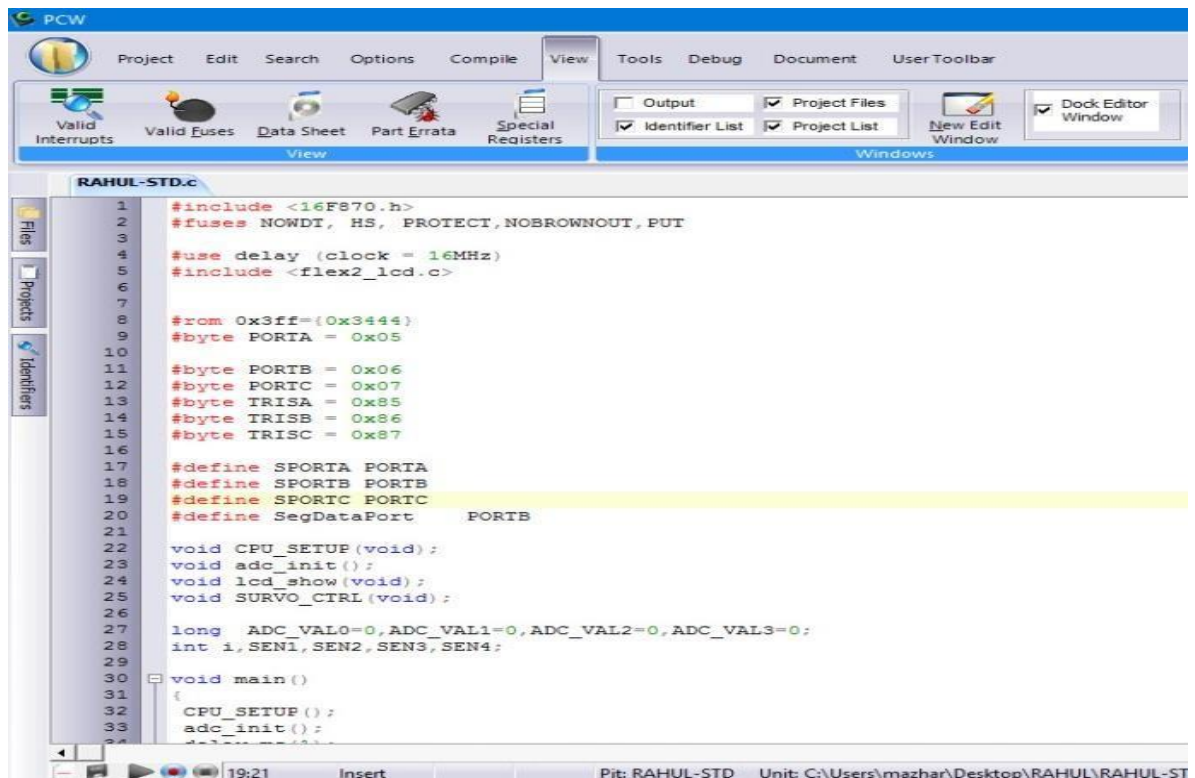

Fig: 3.20 CCS C Compiler

### 3.8.1 Key Compiler Features:

- Easily migrate between all Microchip PIC MCUs devices.
- Minimize development time with: peripheral drivers and standard C constructs.
- C++ style input/output streams with full data formatting to any device or for strings.
- Use CCS libraries and object code royalty free
- The integral one-bit type permits the compiler to generate very efficient Bit-oriented code
- Easily define, set-up and manage interrupts.

### 3.8.2. Proteus Design Suite:

Proteus is a software package for computer-aided design, simulation and design of electronic circuits. It consists of two main parts, the ISIS, the circuit design environment that even the simulator VSM includes, and the ARES, the PCB –Designer. Proteus Virtual System Modeling (VSM) has mixed

mode SPICE circuit simulation, animated components and microprocessor models to ease co-simulation of complete microcontroller-based designs.

It offers a range of design features including:

- Schematic capture
- Mixed-mode (analogue and digital circuit) electronic circuit simulation
- Microprocessor / microcontroller simulation
- PCB design with manual and AutoRoute options
- Graph-based simulation

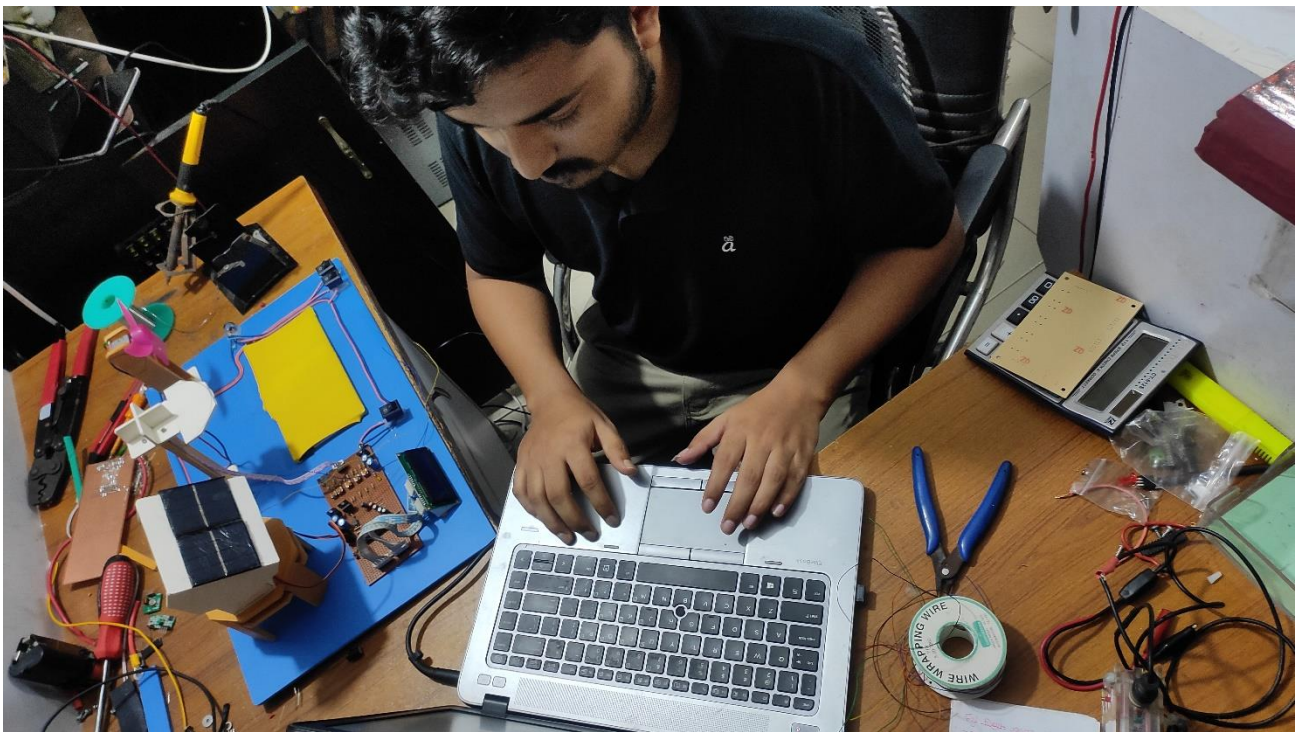

Fig: 3.21 programing our project

# Chapter 4

## RESULT & ANALYSIS

### 4.1 Introduction

The rapid increase in energy demand cannot be resolved easily until there is an alternative way to meet the demand. So, the user will become less compulsive on the convenient fossil fuel energy. The stored energy also plays a significant role to avoid the imbalance of the power system. With the transition away from conventional fossil fuel-based energy sources, a variety of solar energy supplies are now available [18]. Solar energy is one of the utmost major attempts to address the problem of global warming, as well as a source of renewable energy. Additionally, to being a cost-effective source of energy, it may assist in providing a substitute to conventional fossil fuel-based energy a resource. Consumption is actually contained within photovoltaic and thermal energy, necessitating the employment of solar tracking panels.

## 4.2 Comparison of output values between the static solar panel and solar panel with a tracking system:

Time	Static Panel	Tracking Panel	Power Gain by Tracking Panel
	Power(w)	Power(w)	
9:00 AM	0.22	0.32	37.0%
11:00 AM	0.50	0.52	3.92%
1:00 PM	0.64	0.66	3.07%
3:00 PM	0.22	0.40	58.1%
5:00 PM	0.10	0.18	57.1%

This section discusses the comparison results obtained by the outdoor experiments. The power outputs, and the overall efficiency between the static solar panel and solar with tracking mechanism are tabulated and plotted in the time graph. After testing and result we get that dual-axis solar tracking systems generate on average 15-30% more energy compared to static systems.

### 4.3 Comparison Graph:

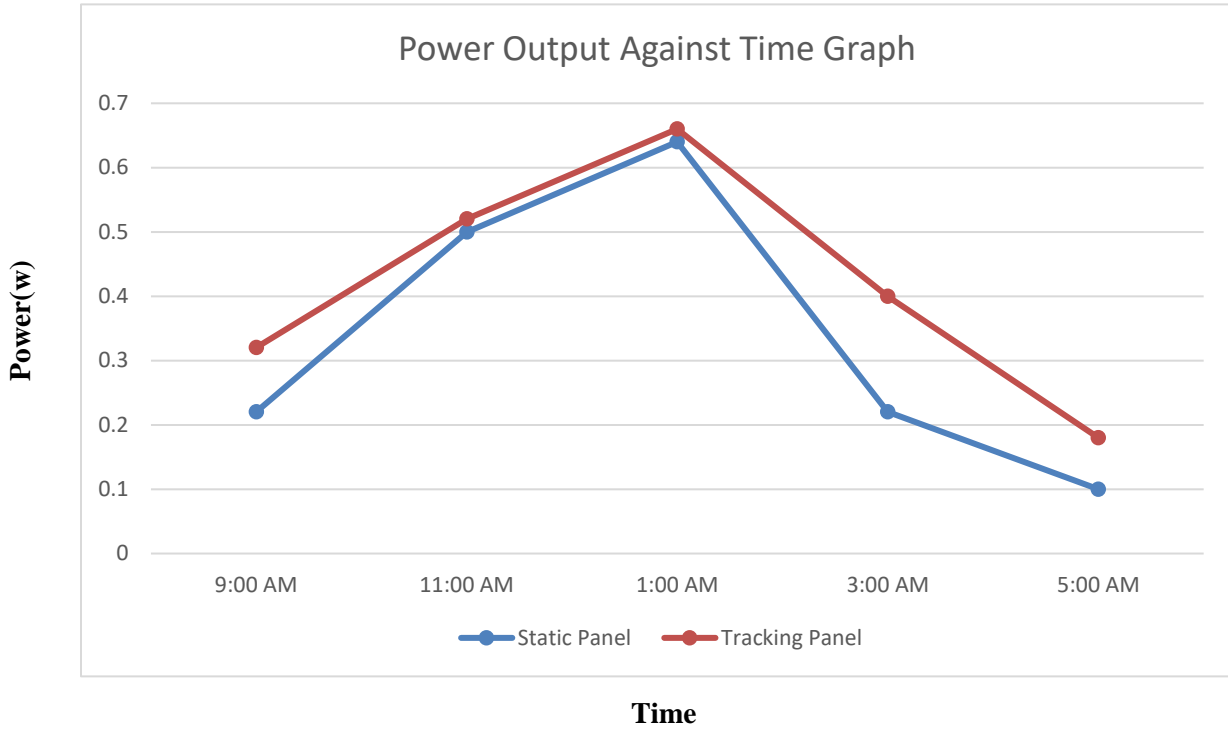

Fig 4.2: Comparison Graph

Based on the comparison graphs, solar panel with solar tracking mechanism has higher performance than static solar panel while there is a similar value from 11.00 am until 2.00 pm due to both solar panels are position horizontally, facing vertically upward and receive the same amount of radiation from the sunlight. While conducting an outdoor experiment, some disturbances will affect the performance of the solar panel, one of the factors will be the weather condition during the time to collect data. There are different weather conditions such as rainy days, cloudy days, and sunny days in Dhaka. The performance of the solar panel would be affected on cloudy days, as the beam radiation of sunlight will be blocked by cloud and the solar panel may not be able to directly received diffused radiation from the Sun.

# Chapter 5

## CONCLUSIONS AND RECOMMENDATION

### 5.1 Summary

The Microcontroller based multi axis solar tracking based solar panel is designed and successfully implemented to increase the efficiency of solar panel. The proposed dual axis solar tracker is more effective than the existing single axis solar tracker and fixed mount. The proposed solar tracker which automatically tracks the sun to grab maximum solar power with the help of microcontroller was effectively achieved. The implementation cost of microcontroller for tracking solar power is low and its implementation is simple.

This paper included a practical work compare the performance of different photovoltaic systems; the solar tracker system was installed in Dhaka-Bangladesh to measure the solar radiation received. The impact of the use of single axis and double axis trackers and compared this influence to fixed solar panel, a solar tracker had been constructed, the three system were tested and got a logical knowledge. The influence of each device on solar energy systems were, the single axis tracker system tends to 29.83% Improvement of power generated relative to the fixed solar panel; the dual axis tracker system tends to 37.05% Improvement of power generated relative to the fixed solar panel while double axis tracker system tends to 7.7% rise compare to the fixed solar panel.

Finally, this project successfully enhances the potential of a stationary solar panel by effectively implementing a tracker using LDRs and Microcontroller which is a coherent method of increasing efficacy and solar power generation. The main destination of this project is to achieve the highest performance of a Multi axis solar tracking system.

With the available resources and time, the objective of the project was met.

### 5.2 Recommendation

The following are a few suggestions that may be incorporated in the future to improve the model:

- In the future, more efficient sensors that are both cost effective and use minimal power may be considered for future projects. This would improve efficiency.



- A polycrystalline solar panel is utilized in this model; however, for greater energy output, the model may be equipped with monocrystalline solar panels, which are more efficient when production scale exceeds 1KW.
- Use higher motors with greater torque values for larger panels, which helps produce a higher solar energy output.
- As sensor-based tracking can have limitations such as dust and clouds obstructing the sunlight.

In this project, we have worked on different sun angles and mainly the solar radiation for different systems. We have ignored different factors like humidity, sun intensity etc.

So, here is a scope to improve it more and make it more accurate.

## **5.3 Discussions and Conclusions**

### **5.3.1 Discussion:**

In this work, a MPPT charge controller is presented. A microcontroller is used to control the maximum power point tracking algorithm, which is used in PV systems to maximize the photovoltaic array o/p power.

An optimized and effective technique has been proposed considering the discussed drawbacks. The proposed system was simulated and constructed, and the functionality of the suggested control concept was proven. The proposed system was simulated and constructed, and the functionality of the suggested control concept was proven. From the results acquired during the simulations and hardware experiments, it was confirmed that, with a well-designed system including a proper converter and selecting an efficient and proven algorithm, the implementation of MPPT is simple and can be easily constructed to achieve an acceptable efficiency level of the PV modules. The results also indicate that the proposed control system is capable of tracking the PV array maximum power and thus improves the efficiency of the PV system and reduces low power loss and system cost. This method protects the MPPT effects from environmental variations and leads us to proper direction to the tracker which makes it independent of environmental changes (particularly irradiation and temperature). The method has been modified based on the incremental conductance and the simulated result offers high efficiency during stable conditions as well as fast changing conditions and hence it maintains the advantage of the existing methods.

The work executed in this project deals with analyzing and modeling of transformer less PV systems related to the leakage current phenomenon that can degrade solar panel performance and pose human. Additionally, leakage current is an unwanted loss especially when it comes to distributed generation system. One of the major tasks of this research was to investigate and verify the transformer less topologies and control strategies that would minimize the leakage current of PV inverter topologies so that it can comply with the standard requirements, safety of human interaction and mitigation of unwanted losses.

### **5.3.2. Conclusion:**

In conclusion, the dual-axis solar tracking system offers significant advantages in maximizing the efficiency and output of solar panels. By continuously aligning the panels with the sun's position throughout the day, the system ensures optimal solar energy absorption, resulting in improved power generation. The rapid increase in energy demand cannot be resolved easily until there is an alternative way to meet the demand. The micro grid can undertake to solve this sort of situation in future. Solar, wind and biomass energy are the main source of energy used for optimizing the overall system and hence to make it efficient. So, the user will become less compulsive on the convenient fossil fuel energy. The stored energy also plays a significant role to avoid the imbalance of the power system. To ensure the photovoltaic generator operating its maximum power point, MPPT controllers are often used. These controllers are intended for MPP tracking and to thus minimize the error between the operating power and the reference maximum power which is variable according to the load and of the weather conditions. The MPPT based charge controllers are best suitable for wind and solar systems as they track the maximum power in case of power fluctuations at the input side due to environmental condition variation. Hence it is recommended to use the MPPT based charge controllers. Use of microcontroller-based systems provides huge computational capability and reduction in the hardware. The MPPT charge controller operates with high efficiency (90% or even higher) as compared to existing charge controllers.

#### **5.4 Suggestion for Future work:**

The main objective of this project is to achieve the highest performance a solar charge controller using MPPT system. This system successfully uses MPPT algorithm to reach our goal. Reaching a stable, true MPP at steady state instead of oscillating around this point would improve the system's efficiency and improve reliability.

## Appendix

```
#include <16F73.h>

#use delay (clock = 16000000)    // HEADER FILES

INT V,A,W;

////////////////////////////////////

void main()

{

lcd_gotoxy(1,1);

printf(lcd_putc, " WELCOME SU ");

lcd_gotoxy(1,2);

printf(lcd_putc, "  L.H.S  ");

delay_ms(1000);

lcd_gotoxy(1,1);

printf(lcd_putc, "SUBMITTED BY: ");

lcd_gotoxy(1,2);

printf(lcd_putc, " SOHEL RANA ");

delay_ms(1500);

lcd_gotoxy(1,1);

printf(lcd_putc, , " MD. AMDADUL HOQUE ");

lcd_gotoxy(1,2);

printf(lcd_putc, , " MD. SAIFUL GANI

CHOWDHURI ");
```

```

delay_ms(2500);

lcd_gotoxy(1,1)

printf(lcd_putc, " MD IFTAKHAR ALAM ASIF ");

lcd_gotoxy(1,2);

printf(lcd_putc, " MD. MEHEDI

HASAN KABIR ");

delay_ms(2500);

}

while(1)

{

lcd_gotoxy(1,1);

printf(lcd_putc, "B:BV LDR1 LDR2 LDR3 ");

lcd_gotoxy(1,2);

printf(lcd_putc, "I:A    P:W    ");

SURVO_CTRL();

////////////////////

set_adc_channel( 0 );

LDR1 = read_adc();

set_adc_channel( 1 );

LDR2 = read_adc();

set_adc_channel( 2 );

LDR3 = read_adc();

set_adc_channel( 3 );V

```

```

= read_adc();

set_adc_channel( 4 );A

= read_adc();

W=(V*I);

////////////////////////////////

}

} // end main()

////////////////////////////////

void SURVO_CTRL(void)

{

//////////////////////////////// SURVO-1 CONTROL //////////////////////////////////

if( LDR0 > LDR1 )

s1ds++;

if( LDR0 < LDR1 )

s1ds--;

//////////////////////////////// SUUURVO-2 CONTROL //////////////////////////////////

if( LDR0 > LDR2 )

s2ds++;

if( LDR0 < LDR2 )

s2ds--;

//////////////////////////////// LOAD CONTROL //////////////////////////////////

}

```

## REFERENCES

- [1] Mihnea Rosu, Hamzescu, Sergiu Oprea, 2013 Microchip Technology Inc., U.S.A., ISBN: 9781620772164.
- [2] Trishan Efram, IEEE TRANSACTIONS ON ENERGY CONVERSION, VOL. 22, NO. 2, JUNE 2007.
- [3] Mr. S. K. Patil, Mr.D.K.Mahadik, IOSR Journal of Electronics and Communication Engineering (IOSR-JECE), ISSN: 2278-2834-, ISBN: 2278-8735, PP: 27-33.
- [4] Australian Energy Research Laboratories (AERL), website. [Online].
- [5] John E. Pfeifer, Fabio A.M. Pereira, Herbert E. Flynn, “DEVELOPMENT OF A MICROCONTROLLER BASED SOLAR PHOTOVOLTAIC MPPT CHARGE CONTROL SYSTEM Using INCREMENTAL CONDUCTANCE METHOD”, academia.edu (May 15, 2008), Publication number:US20080111517 A1.
- [6] Chekireda, C. Larbesa, D. Rekiouab, F. Haddad, Energy Procedia, Volume 6, 2011, Pages 541–549
- [7] S. Kolsi, H. Samet, M. Ben Amar, Journal of Power and Energy Engineering, Vol.4 No.3, September 2015, DOI: 10.4236/jpee.2014.21004
- [8] J. D. P. Pacheco, H. L. Hey, J. Imhoff, IEEE Transactions on Industrial Electronics, (Volume: 55, Issue:7), July 2008.

- [9] Hairul Nissah Zainudin, Saad Mekhilef, Proceedings of the 14th International Middle East Power Systems Conference (MEPCON'10), Cairo University, Egypt, December 19-21, 2010, Paper ID 278.
- [10] A. Safari and S. Mekhilef, "Simulation and hardware implementation of incremental conductance MPPT with direct control method using Cuk converter," IEEE Trans. Ind. Electron, vol. 58, pp. 1154–1161, April 2011.
- [11] Ching-Lung Lin, "Case Study of Solar Power Producing Efficiency from a Photovoltaic System", Open Journal of Energy Efficiency, 4, 45-52. DOI: 10.4236/ojee.2015.43005, Vol.4 No.3, September 2015.
- [12] Kolsi, S., Samet, H. and Amar, "Design Analysis of DC-DC Converters Connected to a Photovoltaic Generator and Controlled by MPPT for Optimal Energy Transfer throughout a Clear Day", Journal of Power and Energy Engineering, 2, 27-34. DOI: 10.4236/jpee.2014.21004, Vol.2 No.1, January 2014, PP. 27-34
- [13] C. Liu, B. Wu, and R. Cheung, "Advanced algorithm for MPPT control of photovoltaic systems," in Canadian Solar Buildings Conference Montreal, Solar Buildings Research Network, 2004.
- [14] J.-M. Kwon, K.-H. Nam, and B.-H. Kwon, "Photovoltaic power conditioning system with line connection," Industrial Electronics, IEEE Transactions on, vol. 53, no. 4, pp. 1048– 1054, 2006.
- [15] T. Kerekes, R. Teodorescu, P. Rodriguez, G. Vazquez, and E. Aldabas, "A New High-Efficiency Single-Phase Transformer less PV Inverter Topology," IEEE Transactions on Industrial Electronics, vol. 58, pp. 184-191, 2011
- [16] Lata K Padole, Rajesh N. Patil, INTERNATIONAL JOURNAL OF ENGINEERING SCIENCES & RESEARCH TECHNOLOGY, ISSN: 2277-9655(I2OR), Publication Impact Factor: 3.785, January, 2016



**THANK YOU**

--- END ---