

AIR PURIFIER AND AIR QUALITY MONITORING SYSTEM

A Thesis

By

Md. Matiur Rahman

ID: ME 2002021231

Tanveer Ahmed

ID: BME 1902018313

Md. Rased Hasan

ID: ME 2002021185

Md. Zahidul Islam

ID: BME 1903019494



DEPARTMENT OF MECHANICAL ENGINEERING
SONARGAON UNIVERSITY (SU)

JANUARY 2024

AIR PURIFIER AND AIR QUALITY MONITORING SYSTEM

A Thesis

By

Md. Matiur Rahman

ID: ME 2002021231

Session: 2020 - 2021

Tanveer Ahmed

ID: BME 1902018313

Session: 2019 - 2020

Md. Rased Hasan

ID: ME 2002021185

Session: 2020 - 2021

Md. Zahidul Islam

ID: BME 1903019494

Session: 2019 - 2020

.....
Supervisor

Shahinur Rahman

Lecturer of Mechanical Engineering

**DEPARTMENT OF MECHANICAL ENGINEERING
SONARGAON UNIVERSITY (SU)**

In partial fulfillment of the requirement for the award of the degree

Of

Bachelor Of science in Mechanical Engineering

JANUARY 2024

ACKNOWLEDGEMENT

First of all, we are grateful to Allah, the almighty for giving us the courage and enthusiasm to complete the thesis work. The authors express their gratitude to “Shahinur Rahman” for his constant & meticulous supervision, valuable suggestion and encouragement to carry out this work. For all this, the authors acknowledge their sincere gratitude to him. We are also grateful to all our thesis & project working team of SU for their help in construction of the project work and give their valuable knowledge and time for completing the experiment. Finally, we would like to thank everybody who supported us in any respect for the completion of the thesis.

ABSTRACT

The present study deals with an evaluation of the air purifier's effectiveness in reducing the concentration of different sized particulate matter and ions in the real-world indoor environment. Two types of air purifiers (API and APII) mainly equipped with High-Efficiency Particulate Air (HEPA) filters that differed in other specifications were employed in general indoor air and the presence of an external source (candles and incense). An air purifier is provided having a purifier housing and an air way housing mounted therein. A fan having a cylindrical whirlpool leaf construction is mounted within the air way housing and air is directed in a predetermined direction through an air exit opening formed in a wall of the purifier housing. In this cylindrical house air input from down and HEPA filter is refine the air and an exhaust fan flow the fresh air in outside.

TABLE OF CONTENTS

ACKNOWLEDGEMENT	ii
ABSTRACT	iii
TABLE OF CONTENTS	iv
LIST OF FIGURE	vi
CHAPTER 1: INTRODUCTION	1-4
1.1 Introduction.....	1
1.2 Background Study	2
1.3 Air Purifier	3
1.4 Uses And Benefits of An Air Purifier	3
1.5 Objectives	3
1.6 Organization of the Book	4
CHAPTER 2: LITERATURE REVIEW	5-14
2.1 Introduction	5
2.2 Air Purifier Technology	5
2.3 Filters Available To Purify Air	5
2.4 Literature Review	6
2.5 Block Diagram.....	13
2.6 Schematic Diagram.....	13
2.7 Components List	14
2.8 Summary.....	14
CHAPTER 3: HARDWARE ANALYSIS	15-42
3.1 Hepa Technology	15
3.2 AC Exhaust Fan	19
3.3 Arduino Nano	22
3.4 MQ 135 Air Quality Monitoring System.....	25
3.5 LCD Display.....	30
3.6 Switch Mode Power Supply (SMPS)	31

3.7 UV Light.....	36
3.8 Temperature Sensor	38
3.9 Arduino IDE	38
3.10 Easy EDA Software	41
CHAPTER 4: METHODOLOGY	43-46
4.1 Our methodologies for the project.....	43
4.2 Hardware Parts	43
4.3 Our Final System Working Mechanism.....	44
4.4 Our Project Final Image.....	44
4.5 Cost Analysis	45
4.6 Working Principle	46
CHAPTER 5: RESULT & DISCUSSION	47-49
5.1 Discussion.....	47
5.2 Result	47
5.3 Advantages	48
5.4 Disadvantages	49
5.5 Applications.....	49
5.6 Experiment Result.....	49
CHAPTER 6: CONCLUSION	50
6.1 Conclusion	50
6.2 Future Scope	50
REFERENCE	51-53

LIST OF FIGURES

FIGURE NO	FIGURE NAME	PAGE NO
2.1	Block Diagram	13
2.2	Schematic Diagram of our circuit	13
3.1	HEPA Filter Working	15
3.2	HEPA Filter Working	16
3.3	Filter absorb the small particle	16
3.4	AC Exhaust Fan	20
3.5	Arduino Nano	23
3.6	Arduino Nano Schematic Diagram	23
3.7	How Arduino Nano looks like	24
3.8	Micro controller IC AT mega 328p	24
3.9	MQ 135 Sensor	26
3.10	MQ 135 Pin Out	27
3.11	LCD Display	31
3.12	SMPS	32
3.13	SMPS Circuit	34
3.14	SMPS Circuit Connection	36
3.15	DC Power supply way	36
3.16	UV Light	37
3.17	DHT11 Temperature Sensor	38
3.18	Arduino Software Interface IDE	39
3.19	Easy EDA Software Interface	43
4.1	Steel Base Sheet	44
4.2	Air HEPA Filter	45
4.3	AC Exhaust Fan	45
4.4	Air Rectangle Structure	46
4.5	Our Final System Working Mechanism	46
4.6	Our Final System Overview (Front View)	47
4.7	Our Final System Overview (Inside View)	47
5.1	Temperature and Humidity Measure output	49
5.2	Air Quality Measuring	50

CHAPTER 1

INTRODUCTION

1.1 Introduction

The most common problem during the summer season is pollution, dust, and allergies. With increase in the number of pollutants in the air, there is an increase in the demand for air purifiers. These air purifiers can be used in offices, homes, commercial places, and if their efficiency is high, then they can also be used outdoors. Air purifier is a device used to remove contaminants like dust particles, cloth fibres etc. present in the air. These devices are claimed to be beneficial to people having allergies, and asthma. The commercially graded air purifiers are manufactured as either small stand-alone units or larger units that can be affixed to an air handler unit (AHU) or to a heating ventilation and air-conditioning (HVAC) unit found in the medical, industrial, and commercial industries.

Air purifiers may also be used in industry to remove impurities such as CO₂ from air before processing. A standard air purifier consists of various types of filters, and filter levels to remove the contaminants from the surrounding air. Dhaka faces pollution problems from all sides, as being a highly populated city, it would be subject to the air contaminating effects of the massive use of cars, motorbikes and trucks, many of which are not subject to strict regulations in regards to the age or quality of their engines, or the fuels they run on. There is also the industrial side of the city, contributing to the ever-growing pollution levels.

Factory or production sites such as brick kilns are responsible for the massively elevated levels of pollution. Due to an economic boom and the subsequent increase in demand, Dhaka's kilns are known to produce billions of bricks each year, often relying on unregulated fuel sources for power (such as the burning of coal, wood and any other combustible material) which can release excessive amounts of noxious fumes and smoke into the atmosphere. Besides these two issues, there are problems related to large dust concentrations building up in the city, somewhat similar to the highly polluted city of

Delhi in India, as well as open burning sites where refuse containing organic matter as well as toxic materials such as plastics and rubber are set alight in the streets.

In order to reduce such elevated levels of pollution, many steps would need to be taken, albeit in the face of such economic growth it would a task that the city of Dhaka would be hard pressed to do. The introduction of stricter regulations regarding fuels and vehicles allowed on the road would be helpful in the fight against reducing ambient pollution levels in the air, with the removal of diesel fuel as well as ancient fume producing engines being of large help.

Other steps would be to introduce stricter measures to both factories and construction sites, holding individual organizations accountable for the amount of pollution that they produce, with the possibility of adding fines to those that exceed unsafe levels of pollution, as well as particulate matter. Whilst certainly a compounded issue, the introduction of these initiatives would be a step in the right direction for Dhaka to obtain a cleaner level of air quality, and improve its US AQI readings as well as PM2.5 levels.

1.2 Background Study

In the present scenario pollution become very serious because of urbanization all around the world. So, we need to concern about it because everyday activities are associated to the environment. Make sure the condition is under control government established monitoring facilities to know the current condition. Air pollution is most important problem of the environment, which mainly concentrates in cities. So, we see many cities has develop with the progressively industrialization and urbanization. air quality standards with a diameter smaller than 10 μm . These fine particles are main concern for us because this are capable of easily transported over long distance by the flow of air. And this particles causes respiratory health problems and the recent studies shows that AQI particles can penetrate to deepest part of the lung so this is the major concern for us that's why make a activated carbon air filter which is used to remove this harmful particles from the atmosphere for better health and atmosphere so the main objective of this project to provide affordable activated carbon filter to the house uses and many more.

1.3 Air Purifier

An air purifier is a device which removes contaminants from the air in a room. These devices are extremely beneficial for allergy sufferers, asthmatics and at reducing or eliminating second-hand tobacco smoke. They are also extremely useful for reducing pollutants from a room if you live in a highly polluted environment, for instance New Delhi, Patna or Gwalior; which are among the most air polluted cities in the world. They also help eliminate virus and bacteria from a room which prevents the spread of disease.

1.4 Uses And Benefits of An Air Purifier

Dust, pollen, pet dander, mould spores, and dust mite faeces can act as allergens, triggering allergies in sensitive people. Smoke particles and volatile organic compounds (VOCs) can pose a risk to health. With the advancement in air purification technology, air purifiers are becoming increasingly capable of capturing a greater number of bacterial, virus, and DNA damaging particulates. Air purifiers are used to reduce the concentration of these airborne contaminants and can be useful and fruitful for people who suffer from allergies and asthma.

1.5 Objectives

The objectives of this project are:

- To study of an **Air Purifier and Air Quality Monitoring System**.
- The main objective of making this machine is to do technical advancement in the air purification field. It helps to clean air in pollutant areas and provides quality of air.
- Design an Air Purifier which operates with 6 advanced stages of filtration using: a cold catalyst filter, a cellular-activated carbon filter, an anti-microbial filter, a HEPA filter, an ionizer.
- To overcome the use of traditional marking methods which is done with the help of sprinkling of water to purify air can be reduced.
- To test the performance of the Air Purifier and Air Quality Monitoring System.

1.6 Organization of the Book

- **Chapter 1: Introduction.** This chapter is all about background study, air purifier, use or air purifier, Objectives and thesis book organization.
- **Chapter 2: Literature Review-** Here briefly describe about air purifier technology, filter availability, previous book review, Block diagram, Structural Diagram, Components List and Summary of this chapter.
- **Chapter 3: Hardware Analysis-** This chapter is discussed about our project hardware . Here we describe our hole instrument details.
- **Chapter 4: Methodology–** Here briefly discuss about project methodology, hardware parts, our system working mechanism, project final image, working principle and our system overview.
- **Chapter 5: Results and Discussion–** Here briefly discuss about project discussion, result analysis, advantages, disadvantages, application and our system overview.
- **Chapter 6: Conclusion –** This chapter is all about our thesis future recommendation and this project conclusion.

CHAPTER 2

LITERATURE REVIEW

2.1 Introduction

In this chapter we will discuss some literature review. Here are some of the ideas we got after this project related literature.

2.2 Air Purifier Technology

The best performing air purifiers feature more than one filter technology, and using HEPA style filtration is the key to optimal results. Filtration performance is not ideal without the use of HEPA air purifiers, and symptoms of particle pollution, like allergies and asthma, are not reduced.

2.3 Filters Available To Purify Air

Air filters are device that take away particles, like dirt and VOC (volatile organic compounds) these filters give you good air quality. So, if we see that there are many types of filter available on the market but all have some unique property to ensure you to provide good air for example ionic, carbon, UV air filter and HEPA they are usually employed at the economic, commercial sectors

● IONIC AIR FILTER

Ionic air filter we also say that air ionizer. They are different from the filter because of their work as a negative ion generator. They release a negative ion charge which attached to the pollutants and this bond particle falls down due to weight. By this filter, particles may not be in air, but these particles still present in the room until you vacuum out this particle.

- **HEPA AIR FILTER**

The term HEPA stands for high efficiency particulate air and what that basically means is its special type of filter that captures microscopic particles these particles include things like dust, pollen, bacteria etc. and particulate matter that comes from outdoor air pollution. High efficiency air cleaners are devices that clean the air by removing microscopic contaminants. This leads to cleaner, fresher air to breathe. HEPA filters catch particles which are size of 0.3 microns or larger and it almost takes away up to 99.97% of small particles.

- **CARBON AIR FILTER**

It's been specially treated with oxygen to open up the pores of the carbon atoms. What this process does is increase the total surface area of the charcoal so it can capture certain particles from the air. Those particles include odour and gas molecules. As odours and gases pass through a carbon filter the molecules react with the charcoal and stick to the surface. Essentially this removes bad smells and chemical gases from indoor air from things like paint, volatile organic compounds and more. Particles which are captured by the carbon are carbon monoxide, nitrogen oxides, sulphur dioxide, lead and particulate matter.

- **UV AIR FILTER**

UV light is designed for one purpose to kill airborne bacteria and viruses. As air passes through the air purifier, the UV light shines on the microorganisms and pathogens, and this destroys their DNA structure. After the air is sterilized, those germs are harmless to your health. Wavelength of these rays are 254nm

2.4 Literature Review

HEPA filters were originally classified as top-secret, developed by the US Atomic Energy Commission to protect soldiers from radioactive particles on the battlefield. During World War II, scientists involved in the Manhattan Project used HEPA masks to guard against contaminants from the atomic bomb. Although these early HEPA masks couldn't possibly protect people from atomic radiation, the research spawned the HEPA filter, which provided protection against chlorine gas, mustard gas, and flame throwers. It was not until the 1960s that specifications were standardized and the term HEPA or "High Efficiency Particulate Air" was officially coined by the Department of Energy (DOE).

As defined by the DOE, HEPA filters remove at least 99.97% of dust, pollen, mold, bacteria and any airborne particles with a size of 0.3 microns at 85 liters per minute. From the beginning, HEPA filters were employed to filter out highly hazardous aerosols, toxic carcinogens, radioactive particles, and biohazardous contaminants.

In Germany, brothers Klaus and Manfred Hammes purchased a patent for a simple air filtration system. Using a fiberglass pad attached with small magnets to the air outlet of a residential oil oven, the Hammes brothers were able to filter soot from the air. In 1963, the Hammes brothers simple but effective filter became the first air cleaner to be utilized in homes across Germany. In the same year, US Congress passed the Clean Air Act of 1963 to set standards for the reduction of air pollution through fuel emissions standards. Although it was not Congress first attempt at reducing air pollution, the Clean Air Act of 1963 alerted scientists and consumers of the need to protect our lungs from pollutants such as perfumes, building materials, chemicals, pesticides, and allergens.

No longer classified as top-secret, HEPA air filters became popular in the 1970s and 1980s as more consumers became concerned about air pollution. With the introduction of dozens of products featuring HEPA filters, new and exciting ways to control allergies and asthma finally became widely available for residential use. Originally, the first HEPA air purifiers were bulky, difficult to operate, and traditionally used only in hospital and pharmaceutical settings and among computer chip manufacturers. Then businesses began to take notice of indoor air quality concerns among residential consumers.

In response to the growing demand for cleaner air, Incen AG, the Hammes brothers newly formed company moved to Switzerland and began developing and manufacturing residential air purifiers in 1971. After many years of international success for Incen AG, Frank Hammes, son of Klaus Hammes, began to distribute cabin air filters as add-on accessories for Mercedes-Benz automobiles in 1990.

In 1991, Frank Hammes formed IQAir North America, which has promoted the continual growth and success of the air purification industry. In 1991, through the amazing technology of True Medical HEPA and Activated Carbon, Richard Taylor created a filter that addressed the issues of environmental particulate contamination, chemical toxicity, and odours. It was then that he and his wife Joyce founded Austin Air Systems Limited. Based out of Buffalo,

NY, Austin Air introduced a pre-filter that ensured a HEPA filter life unequaled to anything in the industry. Austin Air's 360-degree intake system draws air into all sides of the air cleaner, maximizing efficiency and delivering more clean air faster. With the largest air cleaner manufacturing facility in the world, Austin Air continues to produce all the parts for their fantastic air purifiers.

Established in 1992, AllerAir quickly became a trusted name in air purification. After a family member of AllerAir founder Sam Teitelbaum developed Multiple Chemical Sensitivity (MCS), Teitelbaum and partner Wayne Martin decided to develop their own air cleaner. Using the combination of true HEPA filters and a MAC-B (mass activated carbon bed) filters, which contain pounds of carbon, AllerAir created an air purifier that safely and effectively removes chemicals, gases, and odours from the air. With offices in the United States, Italy, and Canada, AllerAir air purifiers are used by the Mayo Clinic, IBM, Gucci, Prada, and the U.S. Army.

With more than 100 models to choose from, AllerAir air cleaners are efficient, practical, and cost effective. With headquarters in Stockholm, Sweden, and Chicago, the Blueair air purifier company is committed to creating a healthier environment both indoors and out. Founded in Sweden in 1996, Blueair quickly earned a reputation for high performance, technological innovation, and quality design. A revolutionary combination of mechanical and electrostatic filtration allows Blueair purifiers to capture 99.97% of irritating particles, gases, and odours. With more than five different models, these powerful yet near-silent air cleaners provide a visually-pleasing form and highly effective function.

Now a global leader in the production of specialty products and chemicals and a subsidiary brand of Kaz, Honeywell started as a hot water heater company in 1906 and has a longstanding tradition of supplying safe, reliable, and high-quality products. Acquired by Kaz in July of 2002, Honeywell's indoor air quality products continually meet and exceed the American Lung Association's Health House guidelines with meaningful innovations based on consumer research and insights. With the use of permanent, lifetime HEPA filters, Honeywell air cleaners remove 99.97% of all common, household particles such as dust, pollen, tobacco, smoke, and cat dander. The Honeywell glass-fiber HEPA material helps remove airborne particles without the use of expensive ultraviolet bulbs, chemicals, or other treatments. With a diversity of products to fit your needs, Honeywell offers a series of Home Comfort and Indoor Air Quality Solutions.

In 2002, IQAir air purifiers became the first air cleaners to incorporate H13 class certified HEPA filters, which capture up to 100 times more particles than conventional HEPA filters. H13 class certified HEPA filters, up to that point, had only been used in hospital clean rooms. • Although no longer a top-secret government project, air purifiers still hold the secrets to cleaner air and healthier environments for many asthma and allergy sufferers. Today HEPA air purifiers and filters are used in a variety of critical filtration applications in nuclear, electronic, aerospace, pharmaceutical and medical fields, as well as in homes around the world. Research scholars at home and abroad have done a lot of research. Nowadays, indoor air purification technology is mainly divided into two types: capture type and reactive type. The capture type separates the contaminants from the air fluid by filtration or adsorption, leaving the contaminants in the air purifier. The reaction type principle mainly removes gaseous pollutants (molecular type pollutants) in the air by chemical reaction or ionization.

Common reaction mechanisms are UV sterilization, photocatalysis and chemical catalysis, room temperature thermal catalysis, plasma and ozone oxidation. However, this purification method is easy to cause secondary pollution. There are three common capture air cleaning systems: mechanical filtration, electrostatic precipitator (ESP), and hybrid air purifiers (Chan et al., 2015). In 1963, the German Hammer brothers developed the first indoor mechanical filter to remove soot from indoor air. The main components of mechanical filtration (also known as fiber filtration) are fans and filter dust collectors (Klepeis et al., 2017). The built-in fan draws indoor air into the purifier. The particulate pollutants in the air are filtered by diffusion, interception, impact or inertial force. Its filtration efficiency is affected by the structure of the air purifier, the nature of the filter material and the power of the fan.

This type of purifier uses a wide variety of filter materials, and the filtration function depends mainly on the nature of the material. Porous filter materials such as nonwovens, filter paper and fibrous materials are most commonly used. The air filter for filtering PM_{2.5} is usually made of high-efficiency air filter material (HEPA: High Efficiency Particulate Air), and the material is ultra-fine glass fiber or synthetic fiber, which is often processed into paper. As early as the 1940s, the United States developed the earliest HEPA filter in the Manhattan project, which was used to prevent the spread of radioactive pollutants in the air.

Nowadays, it has been widely used in the nuclear industry, pharmaceutical industry, food industry and semiconductor industry (Oh et al., 2014). The main components of HEPA are mostly glass fiber or quartz fiber. The efficiency of good HEPA material to remove particulate pollutants in the air can be as high as 99.97%. The most important feature of this material is the high efficiency of particle collection, but the resistance is very large. These two parameters depend on the fiber structure (bulk density, fiber diameter and thickness), operating conditions (filtration rate and temperature), and the characteristics of the trapped aerosol (density, particle size, and particle size distribution). The particulate contaminants are first deposited in the filter bed and deposited on the surface of the filter (Park et al., 2017). This process does not affect the apparent filtration rate. After that, a filter cake is formed on the surface of the filter. As the particulate matter continues to deposit, the resistance increases exponentially. Therefore, the requirements and energy consumption of the wind turbines are getting higher. In order to reduce energy consumption, such air purifiers have to periodically replace the filter media material.

Moreover, the filter material is a one-time consumable, which is not economical. In addition, long-term use of this filter can cause contaminants to escape from the filter, producing human-perceivable contaminants. Therefore, the mechanical filter air purifier has a lower market share (Rice et al., 2018). However, primary filtration and intermediate filtration are still widely used in the pre-stage protection of high efficiency filters. The electrostatic precipitator can use either high-voltage positive electrode discharge or high-voltage negative electrode discharge, but they all use corona discharge. It is mainly composed of a discharge electrode and a collecting electrode, and the discharge electrode is connected to the first stage of the DC high voltage power supply. Two prerequisites for corona discharge are high voltage power supplies and electrodes with very small radii. The mechanism of action is to generate static electricity by the corona discharge principle while generating an electrostatic field.

Very small particulate contaminants are ionized into positive ions and electrons as they flow through the high voltage electric field. These particles can collide with other particles or air molecules to charge the latter, and the electrons and positive ions move to the positive and negative electrodes, respectively, to form an electric field across the gas between the two plates. Then, under the action of the electric field force, the charged particles are orientated in the electric field along the direction of the power line to be captured on the collecting

electrode, and this process generates a minute current. The electrostatic air purifier does not need to replace the filter material regularly like a mechanical air purifier. After the power is turned off, the filter can be removed and cleaned for recycling (Shao et al., 2017).

Compared with the mechanical filter, the electrostatic precipitator air purifier is economical and environmentally friendly. Therefore, it is attracting more and more people's attention, becoming the mainstream trend of indoor dust collector research, and at the same time, it is increasingly occupying the dominant market. With the development of this technology, the electrostatic precipitator purifier has higher and higher dust removal efficiency and lower energy consumption. However, during operation, the electrostatic precipitator air purifier generates secondary pollutants, that is, ozone, due to high-voltage electricity ionizing oxygen in the air. Moreover, the ozone concentration generated easily exceeds the indoor average of 0.16 mg/m³ for one hour as stipulated by the National Indoor Air Quality Standard (GB/T18883-2015), which is also the biggest drawback of this type of air purifier. The filtration efficiency of such an air purifier is affected by a number of factors. The flow of air can affect the electrostatic field, which in turn affects the charging and motion of particulate contaminants.

At the same time, if the concentration of particulate matter is high, it will also affect the electrostatic field, air flow field and particle motion. Common electrostatic air purifiers are mainly divided into the following types: the conventional electrostatic air purifier consists of an electrode and a trap plate. The electrodes are placed in a central position. The electric field lines are perpendicular to the direction of air flow. The two-electrode plate electrostatic air purifier can change the voltage. It removes particulate and gaseous contaminants such as NO_x. The hybrid air purifier combines the principle of static electricity with other filtration mechanisms to improve its filtration efficiency and economy. After passing through the electrostatic field, a portion of the particles are captured by the collecting electrode and a portion is captured by the fibrous material. These fiber materials do not require the use of HEPA (HEPA resistance is too high, energy consumption is high) because charged particles charge the fiber filter material, which increases the filtration performance of the fiber material (Wongaree et al., 2016).

The electrostatic precipitator system is designed with a water mist curtain at the front end of the electrostatic precipitator system. On the one hand, it can cool down and lower the high temperature gas to room temperature. On the other hand, the increase of humidity will

cause the condensation of some small particles (especially nanoparticles), thereby increasing the particle size of the particle contaminants and improving the filtration efficiency. The experimental results show that the filtration efficiency of the nano-particles with water mist curtain and water mist curtain is 67.9%~92.9% and 99.2%~99.7%, respectively. The wet electrostatic precipitator system has high filtration efficiency. However, the humidity of the gas is greatly increased, causing discomfort to the human body. Therefore, it is not suitable for use in indoor environments. The first stage of the dual zone electrostatic precipitator system is the particulate pollutant charging area. There is a high voltage electric field in this area, and the particles are charged under the action of a high voltage electric field.

The second stage is the settling area. The particles settle to the collecting plate under the action of an electric field. Such a dust removing device is often used in the field of indoor air purification because of its small size. Today, most of the air-based electrostatic precipitators are used in the market. The main structures include electrostatic precipitators, pre-filters, fiber composite layers, fans and negative ion generators. Physical and chemical adsorption is the main mechanism of action of adsorption air purifiers. The adsorption carriers commonly used in the two are activated carbon, silica gel, molecular sieves or fibers. Physical adsorption often requires that the adsorbent support be porous and have a large specific surface area. The principle is to use the intermolecular force to adsorb the pollutants on the adsorption carrier to achieve the effect of removing pollutants. Today, mainstream air purifiers on the market often use adsorption methods to remove harmful gases or volatile organic compounds, such as sulfur dioxide, hydrogen sulfide, nitrogen oxides, benzene, formaldehyde and toluene in the air (Xiao et al., 2018).

The advantage is that no matter the concentration of the pollutants, the adsorption effect can be good, and the adsorption speed is fast. The chemical adsorption relies on the above-mentioned materials as a carrier, coating a layer of active chemical substance on the surface thereof as needed, or merging with these chemicals to form a novel purification medium. Then, the pollutants in the air are removed by a chemical reaction method. Through catalysis, decomposition, oxidation and neutralization, a variety of harmful substances in the air are adsorbed, thereby achieving the purpose of eliminating pollutants. However, once the adsorption carrier is saturated, it needs to be replaced and cannot be recycled.

2.5 Block Diagram

In our project we have set up an **Air Purifier and Air Quality Monitoring System**. In this circuit we have used one exhaust fan for suck the air in inside of cylinder. Here we also use a air Rectangle type box, air HEPA filter, DHT 11, MQ 135 air quality monitoring sensor etc. In this diagram we will show by block the individual parts.

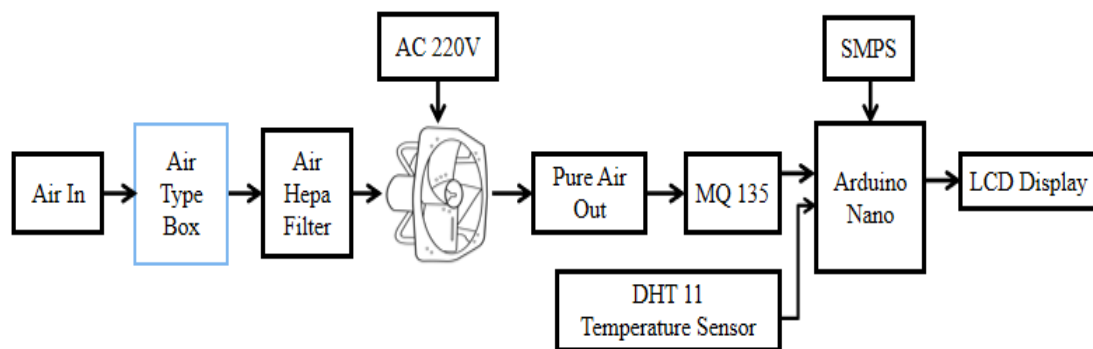

Figure 2.1: Block Diagram of Air Purifier and Air Quality Monitoring System

2.6 Schematic Diagram

The schematic diagram here is representing the electrical circuit and the components of the **Air Purifier System**. Here we connect equipment with the smart wire connection.

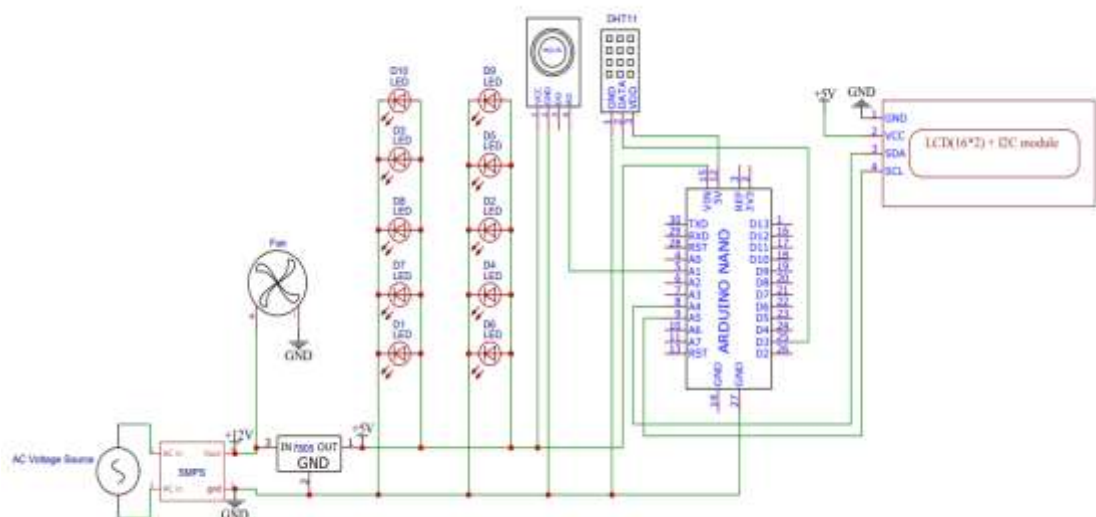

Figure 2.2: Schematic Diagram of our circuit

2.7 Components List:

Hardware Part:

1. Metal Base
2. Steel Air Rectangle Box
3. Exhaust Fan
4. HEPA Filter
5. UV Light
6. DHT 11 Temperature Sensor
7. MQ 135 Air Quality Monitoring System
8. Arduino Nano
9. SMPS
10. LCD Display

Software Part :

1. Arduino Software
2. Easy EDA Software

2.8 Summary

The above discussion gives an idea about the **Air Purifier and Air Quality Monitoring System**. All that work on this system already been done here, and the results of their work, the use of Air Purifier and Air Quality Monitoring System in the situation are described in detail. From this we also got the direction of work of the project.

CHAPTER 3

HARDWARE ANALYSIS

3.1 Hepa Technology

HEPA is an acronym for High Efficiency Particulate Air and is a technology that has been used for many years to filter particles. HEPA filters must meet a standard of trapping at least 99.97% of all particles larger than 0.3 microns. The human eye can only see particles larger than 10 microns; so particles caught in a HEPA filter such as chemicals, bacteria and viruses cannot be seen. Because HEPA filters are able to trap mold and bacteria, they create a more sanitary environment. Additionally, this does not generate ozone or any other harmful byproducts.

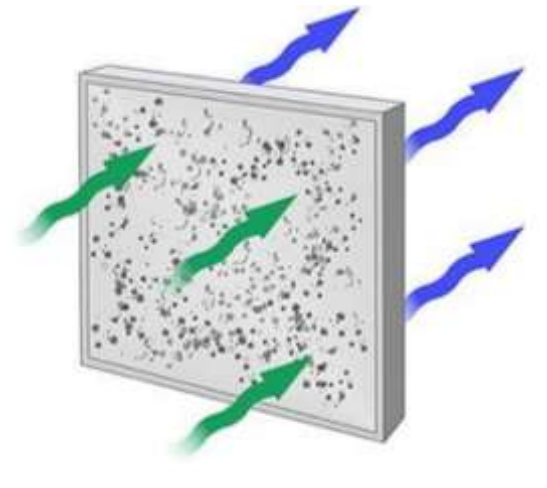

Figure 3.1: HEPA Filter Working

HEPA Filter

The HEPA filter is a very fine fiber-like material that has been folded back and forth to create the shape of an accordion. This accordion shape creates a maze of randomly arranged fibers and presents a very large surface for air to be pushed through by the air purifier fan. Airflow must have an opportunity to pass through the filter in order for it to be cleaned. The more times airflow passes through the filter in an hour, the cleaner the air will become. Components of a HEPA Filter HEPA filters are made of boron silicate microfibers formed into a flat sheet by a process similar to making paper.



Figure 3.2 HEPA Filter

Flat filter sheets are pleated to increase the overall surface area. Pleats are separated by baffles which direct the airflow through the filter. Filter media is very delicate and should never be touched.

How a HEPA Filter Operates

Large particles will not be able to pass through the openings of the fibers and will immediately get caught. The smaller particles will get caught by one of four mechanisms.

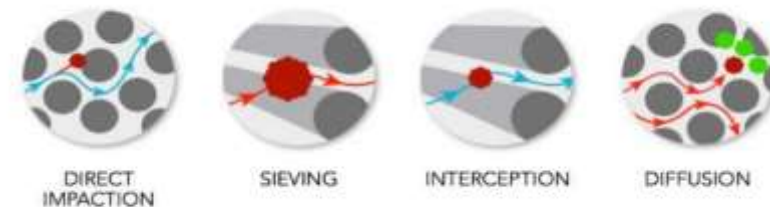

Figure 3.3: Filter absorb the small particle

Direct Impaction: Large contaminants, such as certain types of dust, mold, and pollen, travel in a straight path, collide with a fiber, and stick to it.

Sieving: The air stream carries a particle between two fibers, but the particle is larger than the gap, so it becomes ensnared.

Interception: Airflow is nimble enough to reroute around fibers, but, thanks to inertia, particles continue on their path and stick to the sides of fibers.

Diffusion: Small, ultrafine particles move more erratically than larger ones, so they're more likely to hit and stick to fibers.

HEPA air purifiers are the most effective at trapping airborne particles; however they do not remove odours, chemicals or gases. Therefore, most HEPA air purifiers have some level of activated carbon based material to absorb odours and chemicals not caught by the HEPA filter.

Types of HEPA Filter

An ideal HEPA filter for the best air purifier is the one that captures 99.97% of minute dust particles as minute as 0.3 microns. Only a real HEPA Filter can achieve the above-mentioned objective. Thus, this way you can adjudicate whether your filter is a true HEPA Filter or not. HEPA Filter is classified with A to E stickers depending on their efficiency. Type A is considered to be the least efficient and Type E the most efficient appropriate for defenseless applications. Vacuum Cleaners generally have Type A filters which work efficiently within our house.

HEPA Filter Strengths

- Remove dust, dust mites, pet dander, pollens, mold, some bacteria and other common indoor allergens.
- Air contaminants that have been trapped in the filter won't be released back into the air.
- Does not generate ozone or harmful byproducts.

HEPA Filter Weaknesses

- Won't remove odours, gases, chemical fumes, volatile organic compounds, cigarette smoke, and ultra-small particles, viruses and germs (0.01 microns and below).
- HEPA filter works passively. It requires a fan to draw in air in order to trap air contaminants.
- Bacteria and viruses trapped in the filter can breed and reproduce.

Technology Compliment Hepa Filter

The best technology to pair with HEPA style filtration in air purifiers really depends on your concern. There are many different technologies that are used in air purifiers with HEPA style filtration, such as activated carbon, pre-filters, ultraviolet light, and ionizers. Choosing the best air purifier with the most efficient technology can be easy with some research and comparison. While searching through many air purifiers to find your perfect solution, be aware that the technology used is the most important factor you should consider. □

- **Pre-Filters**

A pre-filter captures the largest particles before they reach the more expensive HEPA filter. Most of the particles in your air are large particles like dander and dust, not tiny ones like pollens and microbes. Even though HEPA filters have a large number of pleats to maximize their surface area, they can fill up quickly if larger particles are not pre-filtered out. □

- **Activated Carbon**

Elements like activated carbon, zeolite, or potassium permanganate are added to air purifier filters to increase efficiency to the filtering system. These elements work to absorb smoke, gases, chemicals, and odours that are present in the air. Activated carbon neutralizes odours and traps harmful chemicals and gases in its pores to provide relief from activities like secondhand smoke, off-gassing from plastics, and harmful fumes produced from renovations. An effective filtering system that is also equipped with chemical adsorption materials can produce cleaner and fresher-smelling air. □

- **Ultraviolet Light**

Ultraviolet light (UV) technology is key to neutralizing viruses and bacteria that accumulate on air purifier air filters. It is important to use the UV technology in combination with HEPA air filters and possibly activated carbon. Without a particulate filter system like a HEPA air filter, too many microorganisms may be hidden from the UV light, since it is not easily located on an air filter.

Table 01 Alternative Filters

Alternative Technology	Pros	Cons
Pre-Filters	Captures large particles • May be washable • Extends life of HEPA filter	Requires maintenance
Activated Carbon	Absorbs odours, gases, and chemicals • Leaves space smelling fresh • Removes tobacco smoke and pet odours	Heavy • Expensive
Ultraviolet Light	•Neutralizes microorganisms, like bacteria and viruses	

3.2 AC Exhaust Fan

Exhaust fans are **used to pull excess moisture and unwanted odors out of a particular room or area**. They are commonly found in bathrooms and kitchens, where moisture can build up due to activities such as showering, washing, or cooking. The existence of clean air in the house is something that every homeowner must pay attention to. As is known, dirty air trapped in the house can cause various diseases, especially respiratory diseases for all family members. Because of that, every house must have a good air circulation system by installing ventilation. As for people who live in urban areas, often the presence of ventilation is not enough to replace the air in the house.



Figure 3.4: AC Exhaust Fan

Exhaust fans are a solution so that the exchange of clean air and dirty air in the house can run well. Sometimes homeowners can install more than 1 exhaust fan in the house. Usually the rooms where the exhaust fan is installed are the bathroom and kitchen or places with poor air circulation. There are various types of exhaust fans available in the market. Just adjust it to the needs and benefits you want to get. Even so, it turns out that the exhaust fan has its own advantages and disadvantages.

Exhaust Fan Advantages

The existence of an exhaust fan provides many advantages, especially if it is installed in a room with poor air circulation. The advantages of exhaust fans include:

1. Improve Indoor Air Quality

Exhaust fans installed in rooms such as bathrooms or kitchens can help improve air quality to be cleaner. Stuffy air like in the bathroom to the smell of cooking that is too strong can be replaced immediately if there is an exhaust fan in the room.

2. Eliminate Bad Smell

The unpleasant and pungent smell is very disturbing. Especially if the aroma comes from a room with a poor air exchange system such as in the bathroom. This makes people think that the room is very dirty and makes people reluctant to enter it. For this reason, the installation of an exhaust fan is necessary to reduce or eliminate unpleasant odors in the room. That way the air in the room remains clean and does not smell when entering the room.

3. Removes Air Moisture

A humid room makes the air stuffy and smelly. If left unchecked, it is not impossible to damage the walls and ceiling of the house because it is too wet. Even in certain parts can be overgrown with moss and fungus which of course can damage a room. For this reason, the installation of an exhaust fan is very useful to quickly remove moisture from the air. That way the air in the room remains dry and not too humid because of good air exchange

by the exhaust fan. Installing an exhaust fan in the bathroom can also help eliminate foggy mirror syndrome due to too high humidity.

4. Reduce Air Contamination

Cooking smoke, cigarette smoke, hot air, and unpleasant odors are very disturbing to the human respiratory system. Especially if the air is dangerous and causes a disease if inhaled for a long time. For this reason, the existence of clean air must always be available in the house in order to provide comfort for every family member. Removing contaminated and dirty air does not need to open all windows and doors of the house, just use an exhaust fan. Because the change of air becomes faster and easier if you use an exhaust fan.

5. Can Be Used as an Air Conditioner

Exhaust fans can also cool the air in the room. This is in accordance with the working principle of the exhaust fan, which is to absorb hot air in the room to the outside, then replace it with new air so that the room becomes cooler.

At first glance, the way it works is similar to a fan, but it is more efficient at dissipating heat in the room.

Disadvantages of Exhaust Fan

Behind the advantages, it turns out that the exhaust fan also has several disadvantages, including:

- Almost all exhaust fans sold on the market use electricity in the form of electricity, so that in the event of a power outage, of course the exhaust fan cannot work.
- Some types of exhaust fans must be installed in the wall or even become one with the ceiling of the house or ceiling. In other words, the exhaust fan cannot be moved anywhere.
- If the installation is not done properly, there is a possibility that hot and humid air can escape to other areas in the house. Not only that, an exhaust fan that is

not properly insulated, when air is drawn from the interior, can be lost in the attic of the house and can actually cause another problem such as damp tiles.

- Improper installation of the exhaust fan can make a noise when the fan rotates. The sound produced is very disturbing to the occupants of the house, so it is very likely that the exhaust fan will not be operated.
- Exhaust fans are only used to remove air from inside to outside the room or in one direction.

Application

Exhaust fans cool down the indoor spaces, ventilate the hot and stuffy air, and can prevent the excess amount of moisture content effectively from building up in the damp areas.

3.3 Arduino Nano

Arduino is an open source electronics prototyping platform based on flexible, easy-to-use hardware and software. It's intended for artists, designers, hobbyists, and anyone interested in creating interactive objects or environments. Arduino can sense the environment by receiving input from a variety of sensors and can affect its surroundings by controlling Lights, motors, and other actuators.

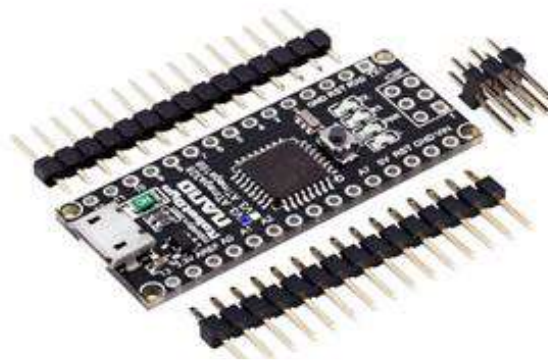

Figure 3.5: Arduino Nano

The micro controller on the board is programmed using the Arduino programming language (based on Wiring) and the Arduino development environment (based on Processing). Arduino projects can be stand-alone or they can communicate with software on running on a computer (e.g. Flash, Processing, Maxims').

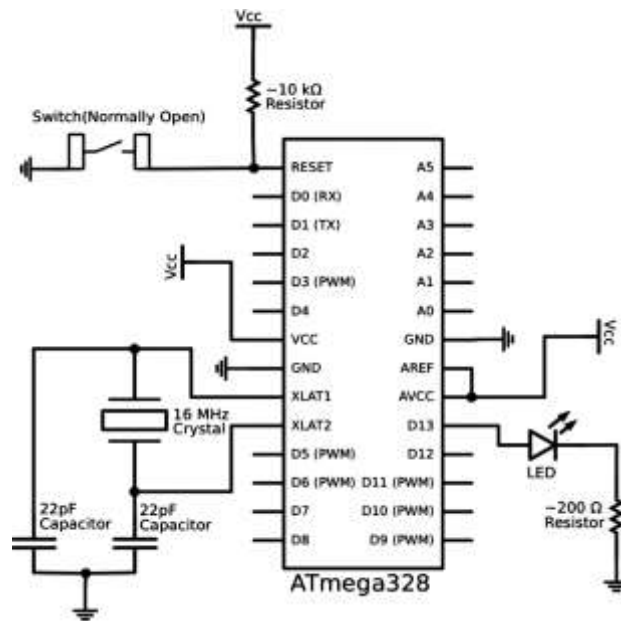

Figure 3.6: Arduino Nano Schematic Diagram

Arduino Nano is a surface mount breadboard embedded version with integrated USB. It is a small, complete, and breadboard friendly component. It has everything that Duemilanove has (electrically) with more analog input pins and onboard +5V AREF jumper. Physically, it is missing power jack. The Nano can automatically sense and switch to the higher potential source of power. Nano's got the breadboard-ability of the Boarding and the Minibus with smaller footprint than either, so users have more breadboard space. It's got a pin layout that works well with the Mini or the Basic Stamp (TX, RX, ATN, and GND on one top, power and ground on the other).

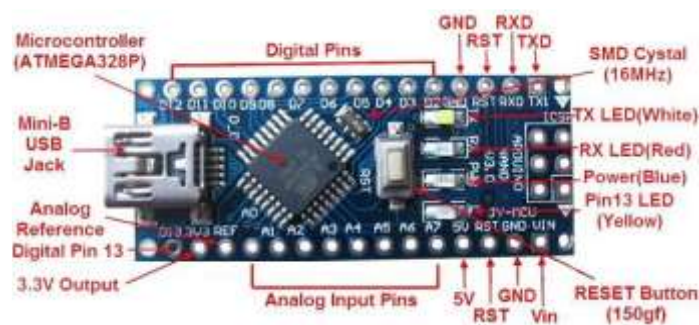

Figure 3.7: How Arduino Nano looks like

Specifications

- Micro controller: Atmel ATmega328
- Operating Voltage (logic level): 5 V
- Input Voltage (recommended): 7-12 V
- Input Voltage (limits): 6-20 V
- Digital I/O Pins: 14 (of which 6 provide PWM output)
- Analog Input Pins: 8
- DC Current per I/O Pin: 40 mA
- Flash Memory: 32 KB (of which 2KB used by boot loader)
- SRAM : 2 KB
- EEPROM: 1 KB
- Clock Speed: 16 MHz
- Dimensions: 0.70" x 1.70"

Micro controller IC ATmega328p



Figure 3.8: Micro controller IC AT mega 328p

Features:

- Automatic reset during program download
- Power OK blue LED
- Green (TX), red (RX) and orange (L) LED
- Auto sensing/switching power input
- Small mini-B USB for programming and serial monitor
- ICSP header for direct program download
- Standard 0.1 spacing DIP (breadboard friendly)
- Manual reset switch

The high-performance Microchip Pico Power 8-bit AVR RISC-based microcontroller combines 32KB ISP flash memory with read-while-write capabilities, 1024B EEPROM, 2KB SRAM, 23 general purpose I/O lines, 32 general purpose working registers, three flexible timer/counters with compare modes, internal and external interrupts, serial programmable USART, a byte-oriented 2-wire serial interface, SPI serial port, a 6-channel 10-bit A/D converter (8-channels in TQFP and QFN/MLF packages), programmable watchdog timer with internal oscillator, and five software selectable power saving modes. The device operates between 1.8-5.5 volts. By executing powerful instructions in a single clock cycle, the device achieves throughput approaching 1 MIPS per MHz, balancing power consumption and processing speed.

3.4 MQ 135 Air Quality Monitoring System

MQ-135 is a gas sensor that has lower conductivity in clean air. It is low cost and suitable for different applications. This module operates at 5V, has $33\Omega \pm 5\%$ resistance, and consumes around 150mA. This sensor has four pins from four pins, Digital and Analog output pins, which are used to approximate these gasses levels in the atmosphere. When these gasses go beyond a threshold limit in the air, the digital pin rises. This threshold value can be set by using the onboard potentiometer.



Figure 3.9: MQ 135 Sensor

Features of MQ-135 Sensor

1. Wide detecting scope, Fast response, and High sensitivity
2. Long lifespan
3. Heater Voltage: 5.0V

4. It contains analog output and high/low digital output
5. The TTL output signal is a low level
6. The operating Voltage is +5V
7. Detected/Measure NH₃, NO_x, alcohol, Benzene, smoke, CO₂, etc.
8. Detection Range: 10 – 300 ppm NH₃, 10 – 1000 ppm Benzene, 10 – 300 Alcohol.

Working Mechanism

The MQ-135 Gas sensor consists of Tin Dioxide (SnO₂). When target pollution gas exists, the sensor's conductivity increases along with the gas concentration. Users can convert the change of conductivity to correspond to the output signal of gas concentration through a simple circuit. The MQ-135 gas sensor has a high sensitivity to NH₃, S₂, C₆H₆ series steam and can monitor smoke and other toxic gasses. It can detect kinds of toxic gasses.

Pin out of MQ135

The MQ-135 sensor module has four pins, with the most important part being an adjustable potentiometer.

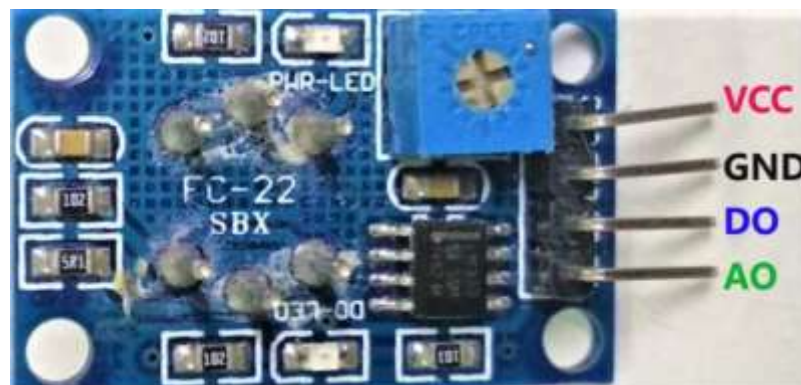

Figure 3.10: MQ 135 Pin Out

The MQ-135 Gas sensor can detect gases like Ammonia (NH₃), sulfur (S), Benzene (C₆H₆), CO₂, and other harmful gases and smoke. Similar to other MQ series gas sensor, this sensor also has a digital and analog output pin.

Pin Number	Pin name	Details
1	VCC Pin	The Pin requires 5V to power the module.
2	Ground Pin	To connect the module to the system's common Ground
3	Digital Output Pin	This pin sets the threshold value by using a potentiometer.
4	Analog Output Pin	The analog voltage pin is based on the concentration of the gas

APPLICATION

They are used in air quality control equipments for buildings/offices, are suitable for detecting of NH₃,NO_x, alcohol, Benzene, smoke,CO₂ ,etc.

SPECIFICATIONS

A. Standard work condition

Symbol	Parameter name	Technical condition	Remarks
V _c	Circuit voltage	5V±0.1	AC OR DC
V _H	Heating voltage	5V±0.1	ACOR DC
R _L	Load resistance	can adjust	
R _H	Heater resistance	33Ω±5%	Room Tem
P _H	Heating consumption	less than 800mw	

B. Environment condition

Symbol	Parameter name	Technical condition	Remarks
T _{ao}	Using Tem	-10 -45	
T _{as}	Storage Tem	-20 -70	
R _H	Related humidity	less than 95%Rh	
O ₂	Oxygen concentration	21%(standard condition)Oxygen concentration can affect sensitivity	minimum value is over 2%

C. Sensitivity characteristic

Symbol	Parameter name	Technical parameter	Remark 2
R_s	Sensing Resistance	30K Ω -200K Ω (100ppm NH ₃)	Detecting concentration scope
α (200/50) NH ₃	Concentration Slope rate	≤ 0.65	10ppm-300ppm NH ₃
Standard Detecting Condition	Temp: 20 \pm 2 Vc:5V \pm 0.1 Humidity: 65% \pm 5% Vh: 5V \pm 0.1		10ppm-1000ppm Benzene
Preheat time	Over 24 hour		10ppm-300ppm Alcohol

D. Structure and configuration, basic measuring circuit

	Parts	Materials
1	Gas sensing layer	SnO ₂
2	Electrode	Au
3	Electrode line	Pt
4	Heater coil	Ni-Cr alloy
5	Tubular ceramic	Al ₂ O ₃
6	Anti-explosion network	Stainless steel gauze (SUS316 100-mesh)
7	Clamp ring	Copper plating Ni
8	Resin base	Bakelite
9	Tube Pin	Copper plating Ni

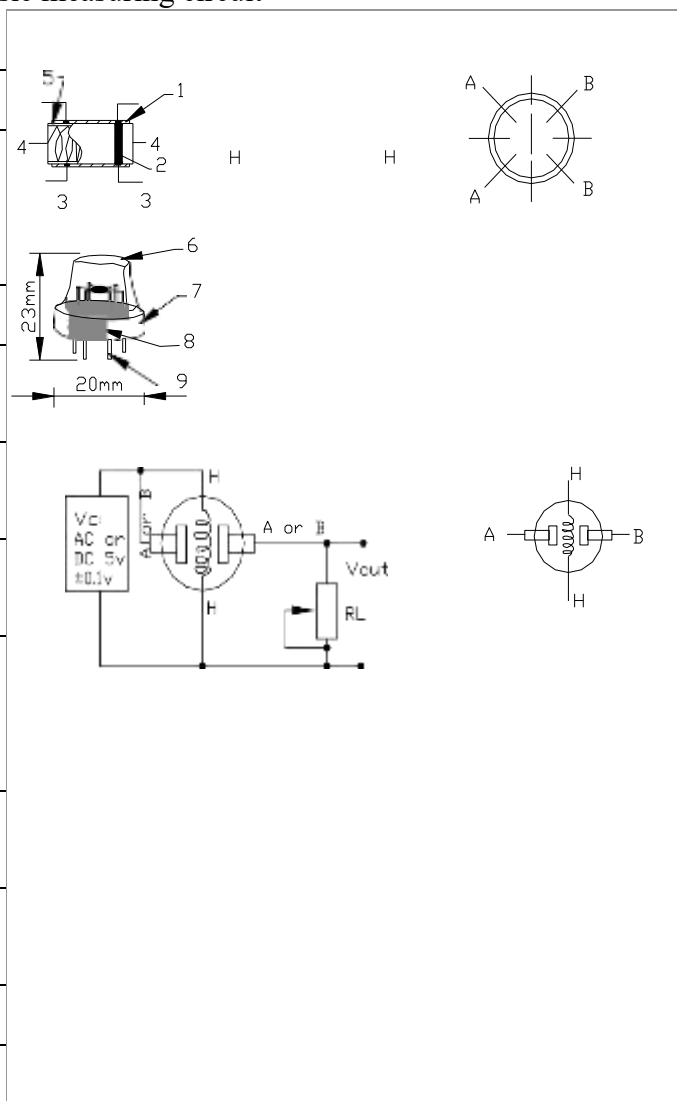

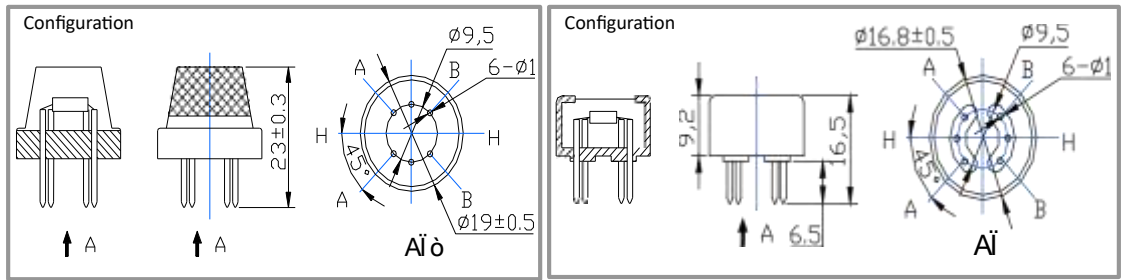

Structure and configuration of MQ-135 gas sensor is shown as Fig. 1 (Configuration A or B), sensor composed by micro AL₂O₃ ceramic tube, Tin Dioxide (SnO₂) sensitive layer, measuring electrode and heater are fixed into a crust made by plastic and stainless steel net. The heater provides necessary work conditions for work of sensitive

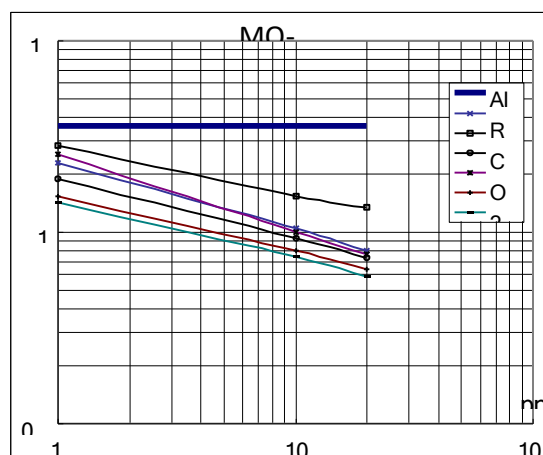
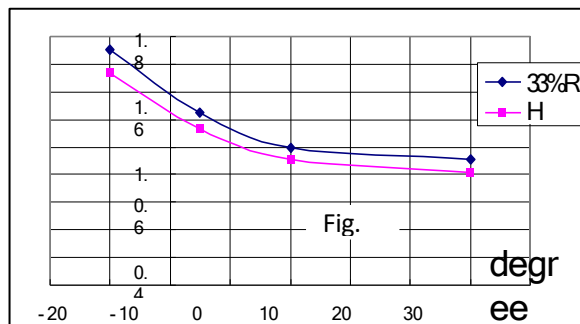

SENSITIVITY ADJUSTMENT

Resistance value of MQ-135 is difference to various kinds and various concentration gases. So, When using this components, sensitivity adjustment is very necessary. we

recommend that you calibrate the detector for 100ppm NH₃ or 50ppm Alcohol concentration in air and use value of Load resistance that(R_L) about 20 KΩ(10KΩ to 47 KΩ). When accurately measuring, the proper alarm point for the gas detector should be determined after considering the temperature and humidity influence.

3.5 LCD Display

The 16 × 2 LCD pin shown below:

- Pin1 (Low / Source PIN): This is a GND display pin, used to connect the GND end of a micro controller unit or power source.
- Pin2 (VCC / Source Pin): This is a display power supply pin, used to connect a power supply pin.
- Pin3 (V0 / VEE / Control Pin): This pin controls the difference of the display, which is used to connect a flexible POT that can deliver 0 to 5V.
- Pin4 (Register Select / Control Pin): This pin turns between a command or data register, which is used to connect a micro controller unit pin and gets 0 or 1 (0 = data mode, and 1 = command mode) .
- Pin5 (Read / Write / Control Pin): This pin shifts the display between the read or written function, and is connected to the micro controller unit pin to get 0 or 1 (0 = Write Task, and 1 = Read Task).
- Pin 6 (Enable / Manage Pin): This pin should be held at the top to perform the reading / writing process, and is connected to the micro controller unit and kept kept high.
- 7-14 Anchors (Data Anchors): These anchors are used to send data to the display. These pins are connected to two wiring modes such as 4-wire mode and 8-wire mode. In 4-wire mode, only four pins are connected to the micro controller unit such as 0 to 3, and in 8-wire mode, 8 pins are connected to the micro controller unit as 0 to 7.
- Pin15 (+ ve LED pin): This pin is connected to + 5V
- Pin 16 (-ve LED pin): This pin is connected to GND.



Figure 3.11: LCD Display

Features of LCD 16x2

The features of this LCD mainly include the following.

- The operating voltage of this LCD is 4.7V-5.3V
- It includes two rows where each row can produce 16-characters.
- The utilization of current is 1mA with no backlight
- Every character can be built with a 5×8-pixel box
- The alphanumeric LCDs alphabets & numbers
- Is display can work on two modes like 4-bit & 8-bit
- These are obtainable in Blue & Green Backlight
- It displays a few custom generated characters

3.6 Switch Mode Power Supply (SMPS)

A switched-mode power supply (switching-mode power supply, switch-mode power supply, switched power supply, SMPS, or switcher) is an electronic power supply that incorporates a switching regulator to convert electrical power efficiently. Like other power supplies, an SMPS transfers power from a DC or AC source (often mains power) to DC loads, such as a personal computer, while converting voltage and current characteristics. Unlike a linear power supply, the pass transistor of a switching-mode supply continually switches between low-dissipation, full-on and full-off states, and spends very little time in the high dissipation transitions, which minimizes wasted energy.

A hypothetical ideal switched-mode power supply dissipates no power. Voltage regulation is achieved by varying the ratio of on-to-off time (also known as duty cycles).

In contrast, a linear power supply regulates the output voltage by continually dissipating power in the pass transistor. This higher power conversion efficiency is an important advantage of a switched-mode power supply. Switched-mode power supplies may also be substantially smaller and lighter than a linear supply due to the smaller transformer size and weight.



Figure 3.12: SMPS

Switching regulators are used as replacements for linear regulators when higher efficiency, smaller size or lighter weight are required. They are, however, more complicated; their switching currents can cause electrical noise problems if not carefully suppressed, and simple designs may have a poor power factor.

Switched-mode power supplies are classified according to the type of input and output voltages. The four major categories are:

- AC to DC
- DC to DC
- DC to AC
- AC to AC

A basic isolated AC to DC switched-mode power supply consists of:

- Input rectifier and filter
- Inverter consisting of switching devices such as MOSFETs
- Transformer
- Output rectifier and filter
- Feedback and control circuit

The input DC supply from a rectifier or battery is fed to the inverter where it is turned on and off at high frequencies of between 20 KHz and 200 KHz by the switching MOSFET or power transistors. The high-frequency voltage pulses from the inverter are fed to the transformer primary winding, and the secondary AC output is rectified and smoothed to produce the required DC voltages. A feedback circuit monitors the output voltage and instructs the control circuit to adjust the duty cycle to maintain the output at the desired level.

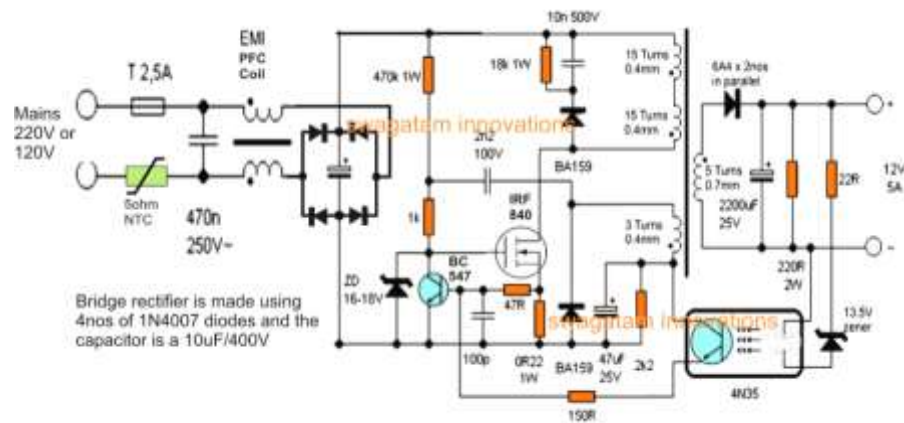

Figure 3.13: SMPS Circuit

Basic working concept of an SMPS

A switching regulator does the regulation in the SMPS. A series switching element turns the current supply to a smoothing capacitor on and off. The voltage on the capacitor controls the time the series element is turned. The continuous switching of the capacitor maintains the voltage at the required level.

Design basics

AC power first passes through fuses and a line filter. Then it is rectified by a full-wave bridge rectifier. The rectified voltage is next applied to the power factor correction (PFC) pre-regulator followed by the downstream DC-DC converter(s). Most computers and small appliances use the International Electrotechnical Commission (IEC) style input connector. As for output connectors and pin outs, except for some industries, such as PC and compact PCI, in general, they are not standardized and are left up to the manufacturer.

There are different circuit configurations known as topologies, each having unique characteristics, advantages and modes of operation, which determines how the input power is transferred to the output. Most of the commonly used topologies such as flyback, push-pull, half bridge and full bridge, consist of a transformer to provide isolation, voltage scaling, and multiple output voltages. The non-isolated configurations do not have a transformer and the power conversion is provided by the inductive energy transfer.

Advantages of switched-mode power supplies:

- Higher efficiency of 68% to 90%
- Regulated and reliable outputs regardless of variations in input supply voltage
- Small size and lighter
- Flexible technology
- High power density
- Disadvantages:
- Generates electromagnetic interference
- Complex circuit design
- Expensive compared to linear supplies

Switched-mode power supplies are used to power a wide variety of equipment such as computers, sensitive electronics, battery-operated devices and other equipment requiring high efficiency. Linear voltage IC regulators have been the basis of power supply designs for many years as they are very good at supplying a continuous fixed voltage output. Linear voltage regulators are generally much more efficient and easier to use than equivalent voltage regulator circuits made from discrete components such a zener diode and a resistor, or transistors and even op-amps.

The most popular linear and fixed output voltage regulator types are by far the 78... positive output voltage series, and the 79... negative output voltage series. These two types of complementary voltage regulators produce a precise and stable voltage output ranging from about 5 volts up to about 24 volts for use in many electronic circuits. There is a wide range of these three-terminal fixed voltage regulators available each with its

own built-in voltage regulation and current limiting circuits. This allows us to create a whole host of different power supply rails and outputs, either single or dual supply, suitable for most electronic circuits and applications. There are even variable voltage linear regulators available as well providing an output voltage which is continually variable from just above zero to a few volts below its maximum voltage output.

Switch Mode Power Supply

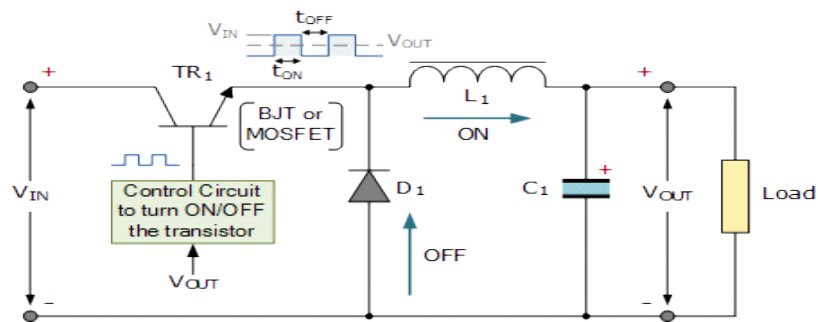

Figure 3.14: SMPS Circuit Connection

Most d.c. power supplies comprise of a large and heavy step-down mains transformer, diode rectification, either full-wave or half-wave, a filter circuit to remove any ripple content from the rectified d.c. producing a suitably smooth d.c. voltage, and some form of voltage regulator or stabiliser circuit, either linear or switching to ensure the correct regulation of the power supplies output voltage under varying load conditions. Then a typical d.c. power supply would look something like this:

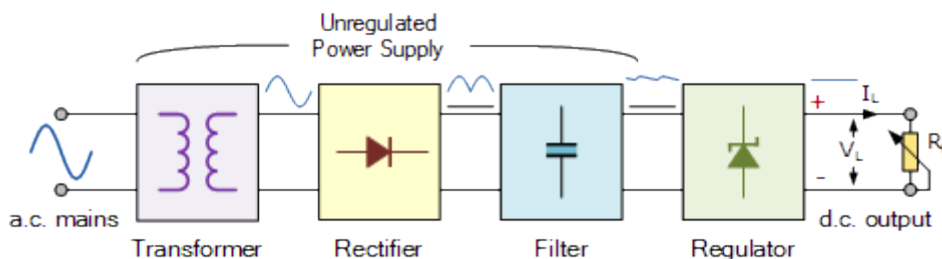

Figure 3.15: DC Power supply way

These typical power supply designs contain a large mains transformer (which also provides isolation between the input and output) and a dissipative series regulator circuit. The regulator circuit could consist of a single zener diode or a three-terminal linear series regulator to produce the required output voltage. The advantage of a linear regulator is

that the power supply circuit only needs an input capacitor, output capacitor and some feedback resistors to set the output voltage.

3.7 UV Light

Ultraviolet (UV) is a form of electromagnetic radiation with wavelength shorter than that of visible light, but longer than X-rays. UV radiation is present in sunlight, and constitutes about 10% of the total electromagnetic radiation output from the Sun. It is also produced by electric arcs; Cherenkov radiation; and specialized lights, such as mercury-vapor lamps, tanning lamps, and black lights.

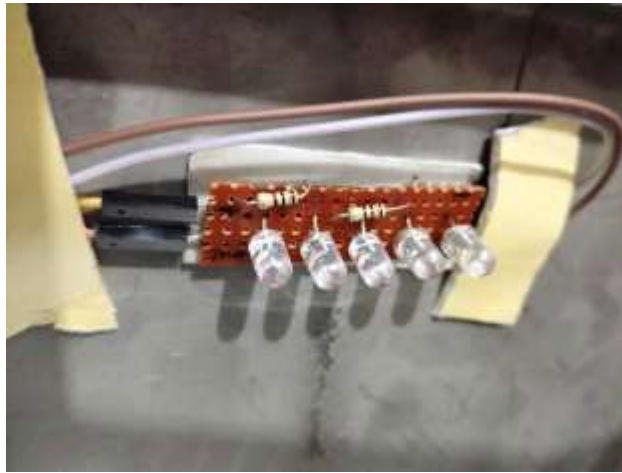

Figure 3.16: UV Light

Although long-wavelength ultraviolet is not considered an ionizing radiation because its photons lack the energy to ionize atoms, it can cause chemical reactions and causes many substances to glow or fluoresce. Many practical applications, including chemical and biological effects, derive from the way that UV radiation can interact with organic molecules. These interactions can involve absorption or adjusting energy states in molecules, but do not necessarily involve heating.[*citation needed*]

Short-wave ultraviolet light damages DNA and sterilizes surfaces with which it comes into contact. For humans, suntan and sunburn are familiar effects of exposure of the skin to UV light, along with an increased risk of skin cancer. The amount of UV light produced by the Sun means that the Earth would not be able to sustain life on dry land if most of that light were not filtered out by the atmosphere.[1] More energetic, shorter-

wavelength "extreme" UV below 121 nm ionizes air so strongly that it is absorbed before it reaches the ground.[2] However, ultraviolet light (specifically, UVB) is also responsible for the formation of vitamin D in most land vertebrates, including humans.[3] The UV spectrum, thus, has effects both beneficial and harmful to life.

The lower wavelength limit of the visible spectrum is conventionally taken as 400 nm, so ultraviolet rays are not visible to humans, although people can sometimes perceive light at shorter wavelengths than this.[4] Insects, birds, and some mammals can see near-UV (NUV), i.e., slightly shorter wavelengths than what humans can see.

3.8 Temperature Sensor

The DHT11 is a basic, ultra-low-cost digital temperature and humidity sensor. It uses a capacitive humidity sensor and a thermistor to measure the surrounding air, and spits out a digital signal on the data pin (no analog input pins needed). It's fairly simple to use, but requires careful timing to grab data.

DHT11 Specifications:

- Operating Voltage: 3.5V to 5.5V
- Operating current: 0.3mA (measuring) 60uA (standby)
- Output: Serial data
- Temperature Range: 0°C to 50°C
- Humidity Range: 20% to 90%
- Resolution: Temperature and Humidity both are 16-bit
- Accuracy: $\pm 1^\circ\text{C}$ and $\pm 1\%$

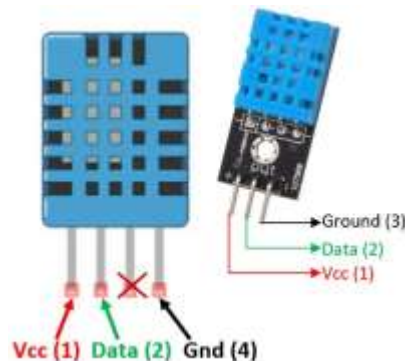

Figure 3.17: DHT11 Temperature Sensor

3.9 Arduino IDE

The digital micro-controller unit named as Arduino Nano can be programmed with the Arduino software IDE. There is no any requirement for installing other software rather than Arduino. Firstly, Select "Arduino Nano from the Tools, Board menu (according to the micro-controller on our board). The IC used named as ATmega328 on the Arduino Nano comes pre burned with a boot loader that allows us to upload new code to it without the use of an external hardware programmer.

Communication is using the original STK500 protocol (reference, C header files). We can also bypass the boot loader and programs the micro-controller through the ICSP (In Circuit Serial Programming) header. The ATmega16U2 (or 8U2 in the rev1 and rev2 boards) firmware source code is available. The ATmega16U2/8U2 is loaded with a DFU boot loader, which can be activated by:



Figure 3.18: Arduino Software Interface IDE

On Rev1 boards: connecting the solder jumper on the back of the board (near the map of Italy) and then resetting the 8U2. On Rev2 or later boards: there is a resistor that pulling the 8U2/16U2 HWB line to ground, making it easier to put into DFU mode. The Arduino Nano is one of the latest digital micro-controller units and has a number of facilities for communicating with a computer, another Arduino, or other micro-controllers. The ATmega328 provides UART TTL at (5V) with serial communication, which is available on digital pins 0 -(RX) for receive the data and pin no.1 (TX) for transmit the data. An ATmega16U2 on the board channels this serial communication over USB and appears as a virtual com port to software on the computer.

The '16U2 firmware uses the standard USB COM drivers, and no external driver is needed. However, on Windows, an .in file is required. The Arduino software includes a serial monitor which allows simple textual data to be sent to and from the Arduino board. The RX and TX LEDs on the board will flash when data is being transmitted via the USB-to-serial chip and USB connection to the computer (but not for serial Communication on pins 0 and 1). A Software Serial library allows for serial communication on any of the Nano's digital pins. The ATmega328 also supports I2C (TWI) and SPI communication.

The Arduino software includes a Wire library to simplify use of the I2C bus. Arduino programs are written in C or C++ and the program code written for Arduino is called sketch. The Arduino IDE uses the GNU tool chain and AVR Lab to compile programs, and for uploading the programs it uses avrdude. As the Arduino platform uses Atmel micro-controllers, Atmel's development environment, AVR Studio or the newer Atmel Studio, may also be used to develop software for the Arduino. The Arduino Integrated Development Environment - or Arduino Software (IDE) - contains a text editor for writing code, a message area, a text console, a toolbar with buttons for common functions and a series of menus. It connects to the Arduino and Genuino hardware to upload programs and communicate with them.

Writing Sketches

Programs written using Arduino Software (IDE) are called sketches. These sketches are written in the text editor and are saved with the file extension .ino. The editor has features for cutting/pasting and for searching/replacing text. The message area gives feedback while saving and exporting and also displays errors. The console displays text output by the Arduino Software (IDE), including complete error messages and other information. The bottom righthand corner of the window displays the configured board and serial port. The toolbar buttons allow you to verify and upload programs, create, open, and save sketches, and open the serial monitor.

Sketchbook

The Arduino Software (IDE) uses the concept of a sketchbook: a standard place to store your programs (or sketches). The sketches in your sketchbook can be opened from the

File > Sketchbook menu or from the Open button on the toolbar. The first time you run the Arduino software, it will automatically create a directory for your sketchbook. You can view or change the location of the sketchbook location from with the Preferences dialog. Beginning with version 1.0, files are saved with a .ino file extension. Previous versions use the .pde extension. You may still open .pde named files in version 1.0 and later, the software will automatically rename the extension to .ino.

Tabs, Multiple Files, and Compilation

Allows you to manage sketches with more than one file (each of which appears in its own tab). These can be normal Arduino code files (no visible extension), C files (.c extension), C++ files (.cpp), or header files (.h).

Uploading

Before uploading your sketch, you need to select the correct items from the Tools > Board and Tools > Port menus. The boards are described below. On the Mac, the serial port is probably something like /dev/tty.usbmodem241 (for an Uno or Mega2560 or Leonardo) or /dev/tty.usbserial-1B1 (for a Duemilanove or earlier USB board), or /dev/tty.USA19QW1b1P1.1 (for a serial board connected with a Keyspan USB-to-Serial adapter). On Windows, it's probably COM1 or COM2 (for a serial board) or COM4, COM5, COM7, or higher (for a USB board) - to find out, you look for USB serial device in the ports section of the Windows Device Manager.

On Linux, it should be /dev/ttyACMx , /dev/ttyUSBx or similar. Once you've selected the correct serial port and board, press the upload button in the toolbar or select the Upload item from the Sketch menu. Current Arduino boards will reset automatically and begin the upload. With older boards (pre-Diecimila) that lack auto-reset, you'll need to press the reset button on the board just before starting the upload. On most boards, you'll see the RX and TX LEDs blink as the sketch is uploaded. The Arduino Software (IDE) will display a message when the upload is complete, or show an error.

Libraries

Libraries provide extra functionality for use in sketches, e.g. working with hardware or manipulating data. To use a library in a sketch, select it from the Sketch > Import Library menu. This will insert one or more #include statements at the top of the sketch and compile the library with your sketch. Because libraries are uploaded to the board with

your sketch, they increase the amount of space it takes up. If a sketch no longer needs a library, simply delete its `#include` statements from the top of your code.

Third-Party Hardware

Support for third-party hardware can be added to the hardware directory of your sketchbook directory. Platforms installed there may include board definitions (which appear in the board menu), core libraries, bootloaders, and programmer definitions. To install, create the hardware directory, then unzip the third-party platform into its own sub-directory. (Don't use "arduino" as the sub-directory name or you'll override the built-in Arduino platform.) To uninstall, simply delete its directory. For details on creating packages for third-party hardware, see the [Arduino IDE 1.5 3rd party Hardware specification](#).

Serial Monitor

This displays serial sent from the Arduino or Genuino board over USB or serial connector. To send data to the board, enter text and click on the "send" button or press enter. Choose the baud rate from the drop-down menu that matches the rate passed to `Serial.begin` in your sketch. Note that on Windows, Mac or Linux the board will reset (it will rerun your sketch) when you connect with the serial monitor. Please note that the Serial Monitor does not process control characters; if your sketch needs a complete management of the serial communication with control characters, you can use an external terminal program and connect it to the COM port assigned to your Arduino board.

3.10 Easy EDA Software

Easy EDA is a web-based EDA tool suite that enables hardware engineers to design, simulate, share - publicly and privately - and discuss schematics, simulations and printed circuit boards. Other features include the creation of a bill of materials, Gerber files and pick and place files and documentary outputs in PDF, PNG and SVG formats. Easy EDA allows the creation and editing of schematic diagrams, SPICE simulation of mixed analogue and digital circuits and the creation and editing of printed circuit board layouts and, optionally, the manufacture of printed circuit boards.

Subscription-free membership is offered for public plus a limited number of private projects. The number of private projects can be increased by contributing high quality

public projects, schematic symbols, and PCB footprints and/or by paying a monthly subscription. Registered users can download Gerber files from the tool free of charge; but for a fee, Easy EDA offers a PCB fabrication service. This service is also able to accept Gerber file inputs from third party tools.

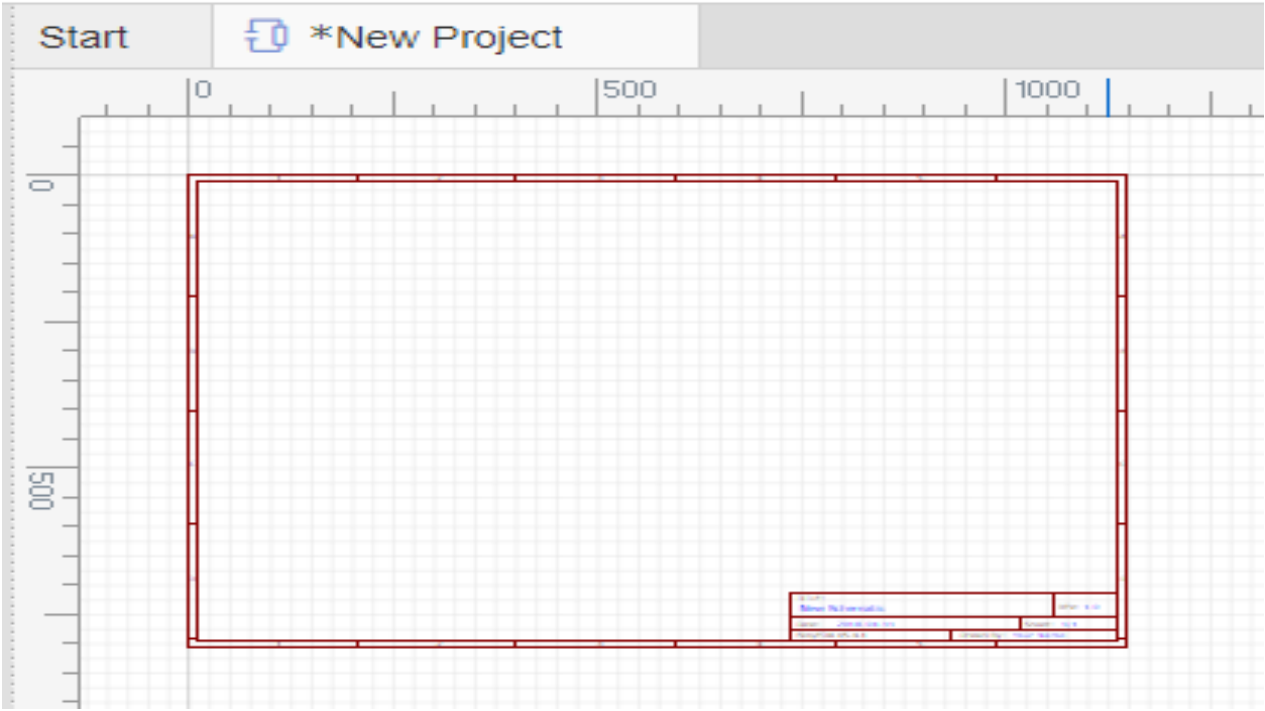

Figure 3.19: Easy EDA Software Interface

CHAPTER 4

METHODOLOGY

4.1 Our methodologies for the project:

- Creating an idea for the design and construction of **Air Purifier System**. And designing a block diagram to know which components we need to construct it.
- Collecting all the components for our desired system.
- Setting up all the components in a system. Then assembling all the blocks in a system and finally running the system to check if it actually works or not.

4.2 Hardware Parts



Figure 4.1: Steel Base Sheet



Figure 4.2: Air HEPA Filter



Figure 4.3: AC Exhaust Fan



Figure 4.4: Air Rectangle Structure

4.3 Our Final System Working Mechanism

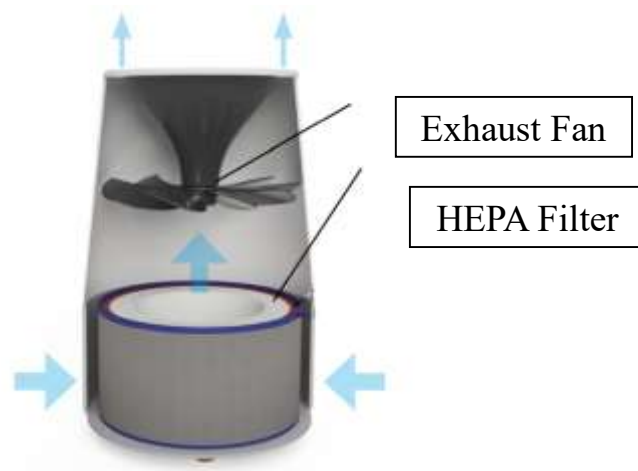

Figure 4.5: Our Final System Working Mechanism

4.4 Our Project Final Image



Figure 4.6: Our Final System Overview (Front View)



Figure 4.7: Our Final System Overview (Inside View)

4.5 Cost Analysis

The below table shows the estimated amount of money we have spent on the project.

Table 01: Component's Name and Purpose of Use

Sl.no	Particulars	Specification	Qty.	Unit Price (Taka)	Total Price (Taka)
1	Arduino Nano	ATmega328P	1	650	650
2	SMPS	12V	1	560	560
3	Hepa Filter		1	2050	2050
4	Air Quality Sensor	MQ135	1	240	240
5	Temperature Sensor	DHT11	1	230	230
6	UV Light		2	140	280
7	AC Exhaust Fan	220V	1	380	380
8	LCD Display	16*2	1	280	280
9	Others				1850
				Total	6520/=

4.6 Working Principle

In this system we want to build an air purifier system. Which is mainly purify the dust air. Here we use an air cylindrical chamber, exhaust fan, HEPA filter, DHT 11, MQ 135 air quality monitoring system, metal base etc. The exhaust fan suck the air from surrounding air from down to upper situation. When the dust air inside the cylinder then the HEPA Filter will purify that air and pure air will blow in other side . In this side we will measure the air purity through a sensor which is MQ 135 air quality monitoring sensor. and DHT 11 sensor measure the temperature. Here we can get the purify air from this system. This is the main procedure of our system.

CHAPTER 5

RESULTS AND DISCUSSION

5.1 Discussion

While working on our project, we did face some difficulties as it is a very complex system but the end results, we came up with were quite satisfactory. We have put the whole system through several tasks to validate our work and also have taken necessary notes for future improvements. Some future recommendations that we have involves improvement in system design and wiring, adding features for more efficient.

5.2 Results

Now, it's time to talk about the results.

- When this project is run then the exhaust fan will be rotate and suck the air into the rectangle box.
- Inside of the system the air will enter the down side of rectangle box.
- Then the HEPA filter will purify the air and pass the upper side of rectangle box.
- In upper side we measure the air purify with the MQ 135 air quality monitoring sensor.



Figure 5.1: Temperature and Humidity Measure output



Figure 5.2: Air Quality Measuring

5.3 Advantages

There are certainly many advantages of our project and some of the major ones have been given below:

- To air purify .
- Produce the fresh air.
- Less skill technicians is sufficient to operate.
- Simple construction
- Ease of operation

5.4 Disadvantages

- Filter must be change after a certain time.
- There is no extra power supply, it only depend on the AC source.
- It is use in small purpose.

5.5 Applications

This project has applications in many fields due its necessity. We have selected a few of them and they are given below:

- It can be use in industrially.
- It can be use large scale in outdoor.
- It can be use in Cabin
- It can be use in Hospitals
- It can be use in Schools

5.6 Experiment Results

- AQI= Air Quality Index

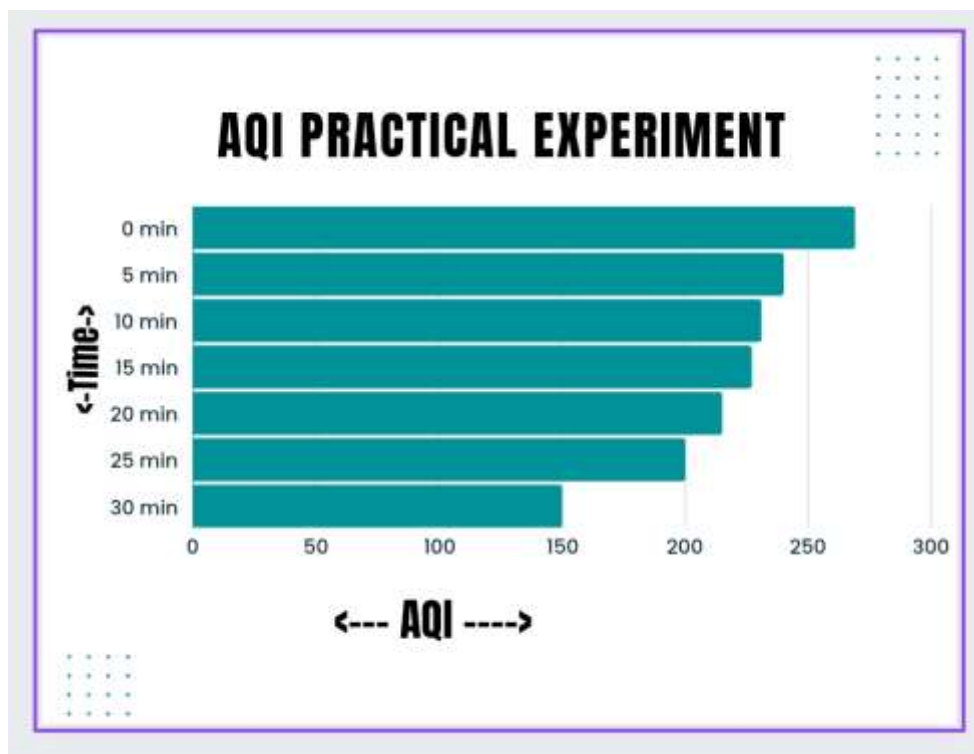

CHAPTER 6

CONCLUSION

6.1 Conclusion

Air cleaners (with HEPA filters) placed in the room chamber effectively reduced the PM concentration to a large extent whereas the concentrations of ions fluctuated. The purifying efficacy of both air purifiers was enhanced in the presence of candles and incense smoke and smaller particles were removed more efficiently as compared to larger ones. Still, PM concentrations were much higher than standards prescribed by national and international agencies that advocate the fact that source control is the best solution to deal with the problem of IAP rather than air purification. On a comparison basis, air purifier with greater CADR and coverage area was more effective on particulate pollution in general indoor air as well as candles and incense smoke support the fact of adoption of air purifier with higher coverage area (or CADR) for air filtration. Though it is a short-term study, it doesn't fully adhere specificity of ions in presence of an air purifier. So, long-term studies are needed to be conducted to clarify the specificity of ions release from air purifiers. For the sake of health safety, air purifiers with mechanical filters (as HEPA) must be used instead of that which releases ions for air purification.

6.2 Future Scope

There's room for improvement and thus, we have lots of future scope of work available to us for this project. Some of these are listed below:

- In future, we are thinking adding more feature on this system to more purify air.
- In future, we are thinking adding solar for power supply.
- In future, we are thinking about increase its working area.
- In future development this project can be develop by more measuring sensor.
- In the future we will add auto alarming system when need to change the filter.

Reference

- [1] Chan W., Lee S.C., Hon A., Liu L., Li D., Zhu N., 2015, Management learning from air purifier tests in hotels: Experiment and action research, *International journal of hospitality management*, 44.
- [2] Hao Z.G., Su X.M., 2018, Determination and Distribution of Indoor Off-odor Pollutants, *Chemical Engineering Transactions*, 68.
- [3] Klepeis N.E., Bellettiere J., Hughes S.C., Nguyen B., Berardi V., Liles S., Hovell M.F., 2017, Fine particles in homes of predominantly low-income families with children and smokers: Key physical and behavioral determinants to inform indoor-air-quality interventions, *PloS one*, 12(5), e0177718, DOI: 10.1371/journal.pone.0177718
- [4] Oh H.J., Nam I.S., Yun H., Kim J., Yang J., Sohn J.R., 2014, Characterization of indoor air quality and efficiency of air purifier in childcare centers, Korea, *Building and Environment*, 82, 203-214, DOI: 10.1016/j.buildenv.2014.08.019
- [5] Park H.K., Cheng K.C., Tetteh A.O., Hildemann L.M., Nadeau K.C., 2017, Effectiveness of air purifier on health outcomes and indoor particles in homes of children with allergic diseases in Fresno, California: A pilot study, *Journal of Asthma*, 54(4), 341-346, DOI: 10.1080/02770903.2016.1218011
- [6] Rice J.L., Brigham E., Dineen R., Muqueeth S., O'keefe G., Regenold S., Diette G.B., 2018, The feasibility of an air purifier and secondhand smoke education intervention in homes of inner city pregnant women and infants living with a smoker, *Environmental research*, 160, 524-530, DOI: 10.1016/j.envres.2017.10.020
- [7] Shao D., Du Y., Liu S., Brunekreef B., Meliefste K., Zhao Q., Xu H., 2017, Cardiorespiratory responses of air filtration: A randomized crossover

intervention trial in seniors living in Beijing: Beijing indoor air purifier study, *Science of the Total Environment*, 603, 541-549, DOI: 10.1016/j.scitotenv.2017.06.095

- [8] Wongaree M., Chiarakorn S., Chuangchote S., Sagawa T., 2016, Photocatalytic performance of electrospun CNT/TiO₂ nanofibers in a simulated air purifier under visible light irradiation, *Environmental Science and Pollution Research*, 23(21), 21395-21406, DOI: 10.1007/s11356-016-7348-z
- [9] Xiao R., Mo J., Zhang Y., Gao D., 2018, An in-situ thermally regenerated air purifier for indoor formaldehyde removal, *Indoor air*, 28(2), 266-275, DOI: 10.1111/ina.12441
- [10] Swati Dhingra, Rajasekhara Babu Madda, Amir H. Gandomi, Senior Member, IEEE, Rizwan Patan, Mahmoud Daneshmand, Life Member, IEEE *IEEE IOT Journal: Internet of Things Mobile - Air Pollution Monitoring System (IoT-Mobair)*.
- [11] Marin Berov Marinov, Dimitar Iliev Iliev, Todor Stoy_nov Djamiykov, Ivan Vladimirov Rachev, Katya Konstantinova Asparuhova *International Scientific Conference of Electronics: Portable Air Purifier with Air Quality Monitoring Sensor*
- [12] Guoliang Liua, Manxuan Xiaob, Xingxing Zhangc, Csilla Galc, Xiangjie Chenb, Lin Liud, Song Pane, Jinshun Wue, Llewellyn Tangb, Elsevier: A review of air filtration technologies for sustainable and healthy building ventilation
- [13] Pathan Sameer Shabbir¹, Shaikh Sururahmed Nijam², Shaikh Tazin Mushtaq³, Dr. Shinde J.N.⁴ *International Journal for Research in Applied Science & Engineering Technology IJRASET : A Survey on Performance Comparison of IOT based Smart Air Purifier*

- [14] Denis J. Dudrey ; Brad Kahlbaugh ; Erland D. United States Patent (US005797973A): AIR FILTRATION ARRANGEMENT AND METHOD.
- [15] Shop Air Filter: Designed by Rob Franklin & Plans by Richard McIntosh
- [16] Manisha Sharma¹, Ajay Kumar², Abhishek Bachhar³ International Conference on Communication and Electronics Systems (ICCES 2017): I2P Air Purifier with Air Quality Monitoring Device
- [17] Building Automation Products Inc. UK Ltd: Determining Air Flow in Cubic Ft./Min.