

Dual Axis Sun Position Solar Tracking with Weather Monitoring System

A report submitted to the Department of Mechanical, Sonargaon University of Bangladesh in partial fulfillment of the requirements for the Award of Degree of Bachelor of Science in Mechanical Engineering.

Submitted by

CHONDON DEVNATH	ID: ME2003022246
MD MAHMUDUR RAHMAN	ID: ME2003022253
MD.AINAL ABEDEN	ID: ME2003022263
TANVER AHAMAD	ID: ME2003022309
MD TARAK HASAN	ID: ME2003022240



Supervised by

**PROF. MD. MOSTOFA HOSSAIN (HEAD)
DEPARTMENT OF MECHANICAL ENGINEERING
SONARGAON UNIVERSITY (SU)
147/1 GREEN ROAD, PANTHAPATH. TEJGAON
DHAKA-1215, BANGLADESH**

MAY 15, 2024

ACKNOWLEDGEMENT

First we started in the name of almighty Allah. This thesis is accomplished under the supervision of **Prof. Md. Mostofa Hossain**, Head, Department of Mechanical Engineering, Sonargaon University. It is a great pleasure to acknowledge our profound gratitude and respect to our supervisor for this consistent guidance, encouragement, helpful suggestion, constructive criticism and endless patience through the progress of this work. The successful completion of this thesis would not have been possible without his persistent motivation and continuous guidance.

The author are also grateful to Md. Mostofa Hossain , Professor & Head of the Department of Mechanical Engineering and all respect teachers of the Mechanical Engineering Department for their co-operation and significant help for completing the thesis work successfully.

[Authors]

CHONDON DEVNATH
ME2003022246

MD MAHMUDUR RAHMAN
ME2003022253

MD.AINAL ABEDEN
ME2003022263

TANVER AHAMAD
ME2003022309

MD TARAK HASAN
ME2003022240

ABSTARCT

Of all the renewable energies, solar energy is the only energy gained its popularity and importance quickly. Through the solar tracking system, we can produce an abundant amount of energy which makes the solar panel's workability much more efficient. The main control circuit is based upon Arduino micro controller. Micro controller is controlled this system by programming. Here also use an Arduino Pro Mini, Buck Converter, LDR Sensor, Servo Motor. The main task of this project is that when the sun reflects on this solar panel, it will charge and save its battery. The LDR sensor then senses the direction of the sun and moves this solar panel automatically. We worked with dual-axis experimentally, stationary solar, and single-axis solar experiments to compare, and finally, we found dual-axis efficiency is more than others.

TABLE OF CONTENTS

DECLARATION	i
CERTIFICATE	ii
ACKNOWLEDGEMENTS	iii
ABSTARCT	iv
TABLE OF CONTENTS	v
List of Figures	vii

Chapter 1: Introduction

1.1	Background	01
1.2	Problem Identification	01
1.3	Motivation	02
1.4	Objectives	02
1.5	Thesis Outline	02

Chapter 2: Literature Review

2.1	Literature Survey	03
2.2	Summary	06

Chapter 3: Component Description

3.1	Required Components and software	07
3.2	Arduino Pro Mini	07
3.3	Solar Panel	10
3.4	Transistor	12
3.5	Resistor	15
3.6	Battery	15
3.7	5V Regulator IC	17
3.8	LDR	17
3.9	Arduino Software	18
3.10	Easy EDA Software	22
3.11	Temperature Sensor	23

Chapter 4: Methodology

4.1	Methodology	24
4.2	Block Diagram	25
4.3	Schematic Diagram	25
4.4	Working Principle	26
4.5	Project Prototype Image	26
4.6	Project Cost Analysis	27

Chapter 5: Results and Discussion

5.1	Data Table	28
5.2	Equation	31
5.3	Graph	32
5.4	Advantages	33
5.5	Application	33
5.6	Limitation of The Research	33
5.7	Discussion	34

Chapter 6: Conclusion

6.1	Conclusion	35
6.2	Future Scope	35

References	36
-------------------	-----------

Appendix	38
-----------------	-----------

LIST OF FIGURES

Figure No	Figure Contain	Page No
Figure 3.1	Arduino Pro Mini	08
Figure 3.2	Arduino Pro Mini Pin Out	9
Figure 3.3	Microcontroller IC AT Mega 328p	10
Figure 3.4	Solar Panel	11
Figure 3.5	BC 547	12
Figure 3.6	Transistor Symbols	12
Figure 3.7	NPN & PNP Transistor Symbol	13
Figure 3.8	Two common resistor schematic symbols	15
Figure 3.9	3.7V Battery	16
Figure 3.10	5V Regulator IC	17
Figure 3.11	LDR	18
Figure 3.12	Arduino Software Interface IDE	20
Figure 3.13	EasyEDA Software Interface	23
Figure 4.1	Block Diagram of our Project	25
Figure 4.2	Circuit Diagram of Our System	25
Figure 4.3	Our Final Project Prototype	26
Figure 5.1	Time vs Pout Graph In Different Solar Module	32
Figure 5.2	Efficiency Chart	32

CHAPTER 1

INTRODUCTION

1.1 Background

Industrial and domestic reliance on the use of fossil fuel is today facing challenges in demand environmental consideration. Dual Axis floating solar panel follow the sun continually and provide constant power output throughout the day with high efficiency by doing azimuth & altitude tracking. 40-50% more energy. 15% more yields due to the cooling effect of water. In Bangladesh, there are huge unused coastal area, pond, canal, and 57 major rivers that will be effective for dual axis floating solar PV Estimated 1,500 km^2 of ponds, Bangladesh has immense potential for dual axis floating PV.

1.2 Problem Identification

Solar power, which is available only in fixed installations, is the major problem. The ability of power that can be generated is restricted as part of this issue. The other factor is that the solar tracking system's purchase price is very high for a family that uses more electricity than normal, so more than one solar panel will need to be installed to generate enough power.[1] So, this concept is all about solving the problem that is going on at 180 degrees, this solar tracking system will detect rotation. So, compared to where the solar panel stays in just one direction, the solar panel mentioned here is extremely large. [2] Solar energy faces another problem.

Usually fixed solar energy panels would not be directly oriented towards sunlight as a result of the continuous motion of the Earth. If the consequence of this system is that it does not achieve the highest efficiency.[3] The solar tracking device is the larger solution for achieving full output power due to this method. This is the primary reason that why the project for the solar tracker is implements. The solar tracker must obey the sunlight in order to get additional power output. The cost of purchasing more solar panels is, indirectly, likely to be reduced. In order to manage sunlight, these devices also slowly take the time users need to change the position of solar energy.[4]

1.3 Motivation

The world's advanced nations are currently working on renewable energy. It is necessary to work with renewable energy to give a beautiful world to the next generation. Our government has also received small projects on renewable energy sources. So, we want to do something about renewable energy sources. As such, our country is a landless and densely populated country. One thing we have seen is that many countries are successfully producing solar power from floating solar power plants.

1.4 Aims and Objectives

We have some specific objectives for this project and they are pointed below:

- To design and build a **Dual Axis Solar Tracker System**.
- To taking notes from our real-time test.
- To follow the position of the sun for maximum energy efficiency.

1.5 Thesis Outline

- **Chapter 1: Introduction.** This chapter is all about background study, problem identification, motivation and aims and objectives.
- **Chapter 2: Literature Review-** Here briefly describe about floating solar panel project, its advantages, disadvantages, application and some live floating solar panel project.
- **Chapter 3: Evaluation of the Developed System -** This chapter is discussed about instrument and software. Hardware and Software details and its working procedure.
- **Chapter 4: The Design Method and Process –** Here briefly discuss about project methodology, Block Diagram, circuit diagram, required instrument cost analysis, working principle, work plan, output curve analysis etc.
- **Chapter 5: Conclusion –** This chapter is all about our project advantages, limitation, application and this project conclusion.

CHAPTER 2

LITERATURE REVIEW

2.1 Literature Survey

This literature review reveals the detailed work that has been carried out till date on the topic of Solar Tracking. N. Othman, M. I. A. Manan, Z. Othman, S. A. M. Al Junid have designed a two-axis sun tracking system with the use of five LDRs and an Arduino nano controller [1].

The objective of this research is to design and construct the automatic dual axis solar tracker for maximum sun energy utilization. The only point of worry is that this system should consume energy as minimum as possible so that the difference between power conversion and power consumption would increase and hence the net profit of the system. Arduino UNO controller has been used and it is programmed in C language. LDRs are used to detect the maximum sunlight position in the sky and the program written performs calculations and drives the servo motors to make PV panels perpendicular to the sun [2].

The sun not only travels from east to west but there is a change of angle in north to south direction also. So the north and south directions should also be taken care of. Dual axis trackers do that. These trackers track the sun on a horizontal as well as vertical axis. Because of this operating ability the dual axis trackers have more output power than the single axis trackers. Light Dependent Resistors are used to find the brightest spot of the sun in the sky. LDRs are connected to Arduino UNO controller which gets to know the position of the sun in the sky and hence rotates the motors towards the sun[3].

Two Servo motors are used for panel rotation which also fulfils the low cost and lightweight criteria [4]. Md. Tanvir Arafat Khan, S.M. Shahrear Tanzil (2010) have designed and constructed a micro-controller based solar tracking system using LDRs to sense the intensity of sunlight and stepper motors to move the Photo-Voltaic (PV) panels in accordance with the sun [5].

Fabian Pineda, and Carlos Andres Arredondo (2011) have designed and implemented a two-axis sun module positioning by sensing the maximum brightness point in the sky. A geodesic dome based sensor has been built for the bright point tracking [6]. Authors Salabila Ahmad et al. have designed and constructed an open loop two axes sun tracking system with an angle controller. The hardware is selected such as it will maximize the power collected and minimize the power consumed as the efficiency parameter lies in between these two power parameters [7].

Solar tracking also helps in transmitting sunlight to dark area like basement. Authors Jifeng Song et al. have implemented the high precision tracking system based on a hybrid strategy for concentrated sunlight transmission via fibers [8]. Author Cemil Sungur (2008) has presented the multi-axes sun tracking system with PLC control. The azimuth and altitude angles of the sun are calculated for a period of 1 year at 37.6° latitude where Turkey is located. According to these angles, an electromechanical system which tracks the sun according to azimuth and altitude angle is designed and implemented [9].

Authors A.chaib et al (2013) have presented the heliostat orientation system based on PLC robot manipulator. It is presented that by mounting certain no. of heliostats and facing them towards central power tower water can be heated and turbines can be driven for energy conversion purpose. By applying MATLAB program for determining the sun's position for heliostat orientation and by using PLC robot manipulator it is presented that maximum amount of energy gets converted from solar to electricity. Concentrated Solar Power (CSP) is used in this experiment [10].

Authors Tao Yu and Guo Wencheng (2010) have introduced automatic sun-tracking control system based on Concentrated Photo Voltaic (CPV) generation. CPV generation works effectively when light panels trace the sun accurately. Stepper tracking control technology is used. This control relies on control circuit with ARM and camera which can provide powerful computational capability [11].

Shreyasi Chakraborty. Nilanjana Mukherjee. Rashmi Biswas in 2017. Due to their many benefits, renewable energy sources are becoming one of the top priorities for today's world. In particular, to meet our ever-increasing energy needs, solar energy is emerging as

a potential source of inexhaustible and unpolluted energy. However, solar panels, which are fundamental components of the conversion of solar energy, are installed at a certain angle and with diurnal and seasonal shifts, are unable to track the direction of sunlight. Using a micro-controller combination, we built a solar tracking system[12].

To meet our ever-increasing energy needs, solar power is emerging as a potentially inexhaustible and non-polluting energy source. Arduino prototype driven automated solar tracking system is primarily designed using Arduino Micro-controller, LDRs, and stepper motors. Three phase motors are typically used to transfer solar power based on the accumulated incident light controlled by LDRS[13].

The software controls this solar panel's vertical tilt point, and it rotates horizontally. Then according to the sunlight incident, it could follow the direction of the sun, not just the vertical rotation as well as the horizontal rotation of the solar panels. This system is therefore capable of optimal lighting and can minimize the cost of electricity production by providing a minimum number of solar panels with proper alignment with all sunlight[14].

Rathika Kannan. Kavitha S in June 2017. Solar tracking system was made with stepper motor tracking system to increase the efficiency of output power of the PV plate. Solar energy is becoming ever more an alternative energy source. It is a device that tracks a solar array's rotation, so it is always associated with the direction of the sun. Developed and mounted in this article, the solar tracker offers a safe and inexpensive way to align a solar panel with the sun to optimize its energy output. In the proper orientation the solar monitoring system is configured to align the photovoltaic solar panel with the sun for direct radiation[15].

Ankit Anuraj Rahul in 2018. As an important tool for renewable energy, solar energy is increasingly rising. Solar tracking helps to collect more solar energy, since a profile that is perpendicular to the sun's rays can be maintained by the solar panel. Whilst initial costs are high for the implementation of a solar tracking device, this paper offers a cheaper solution. The control circuit of the solar tracker relies on an ATmega16 micro-controller. It is intended to sense sunlight through the LDR, and then switches with the stepper motor to

align the solar panel where maximum sunlight can be obtained. The stepper motor is more controllable, more energy-intensive, more powerful and has good precision tracking and little environmental impact compared to any other motor type[16].Shreyasi Chakraborty. Nilanjana Mukherjee. Rashmi Biswas in 2017. Due to their many benefits, renewable energy sources are becoming one of the top priorities for today's world[17].

In particular, to meet our ever-increasing energy needs, solar energy is emerging as a potential source of inexhaustible and unpolluted energy. However, solar panels, which are fundamental components of the conversion of solar energy, are installed at a certain angle and with diurnal and seasonal shifts, are unable to track the direction of sunlight. Using a micro-controller combination, we built a solar tracking system[18].

Thin Hiwe in August 2019. To meet our ever-increasing energy needs, solar power is emerging as a potentially inexhaustible and non-polluting energy source. Arduino prototype driven automated solar tracking system is primarily designed using Arduino Micro-controller, LDRs, and stepper motors Three phase motors are typically used to transfer solar power based on the accumulated incident light controlled by LDRS[19].

The software controls this solar panel's vertical tilt point, and it rotates horizontally. Then according to the sunlight incident, it could follow the direction of the sun, not just the vertical rotation as well as the horizontal rotation of the solar panels. This system is therefore capable of optimal lighting and can minimize the cost of electricity production by providing a minimum number of solar panels with proper alignment with all sunlight[20].

2.2Summary

From the literature discussed above, we gained a lot of knowledge and we inspired to do this project. We were able to do it with everyone tireless work.

CHAPTER 3

COMPONENT DESCRIPTION

3.1 Required Components and Software

Hardware

1. Arduino Pro Mini
2. Solar Panel
3. Buck Converter
4. Battery
5. Servo Motor
6. LDR
7. Capacitor
8. Resistor
9. DC Load
10. Temperature sensor

Software

1. Arduino IDE Software
2. Easy EDA Software

3.2 Arduino Pro Mini

The Arduino Pro Mini is a micro-controller board based on the ATmega328P. It has 14 digital input/output pins (of which 6 can be used as PWM outputs), 6 analog inputs, an on-board resonator, a reset button, and holes for mounting pin headers. A six pin header can be connected to an FTDI cable to provide USB power and communication to the board.

Specification

- Micro-controller ATmega328P

- Operating Voltage: 3.3V or 5V (depending on model)
- Input Voltage: 3.35 -12 V (3.3V model) or 5 - 12 V (5V model)
- Digital I/O Pins: 14 (of which 6 provide PWM output)
- Analog Input Pins: 6
- DC Current per I/O Pin: 40 mA
- Flash Memory: 16 KB (of which 2 KB used by bootloader)
- SRAM: 1 KB
- EEPROM: 512 bytes
- Clock Speed: 8 MHz (3.3V model) or 16 MHz (5V model)

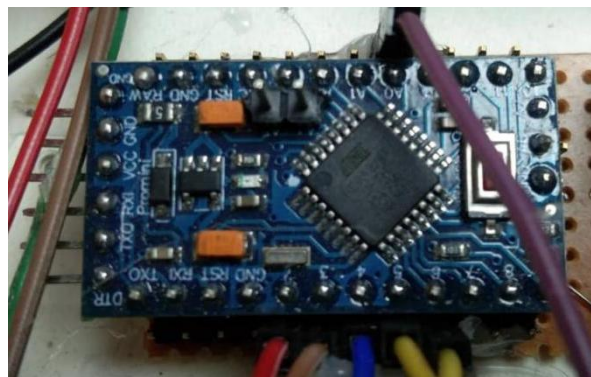

Figure 3.1: Arduino Pro Mini

Pin Out

Each of the 14 digital pins on the Pro Mini can be used as an input or output, using `pinMode()`, `digitalWrite()`, and `digitalRead()` functions. They operate at 3.3 or 5 volts (depending on the model). Each pin can provide or receive a maximum of 40 mA and has an internal pull-up resistor (disconnected by default) of 20-50 k Ohms. In addition, some pins have specialized functions:

- Serial: 0 (RX) and 1 (TX). Used to receive (RX) and transmit (TX) TTL serial data. These pins are connected to the TX-0 and RX-1 pins of the six pin header.
- External Interrupts: 2 and 3. These pins can be configured to trigger an interrupt on a low value, a rising or falling edge, or a change in value. See the `attachInterrupt()` function for details.

- PWM: 3, 5, 6, 9, 10, and 11. Provide 8-bit PWM output with the analogWrite() function.
- SPI: 10 (SS), 11 (MOSI), 12 (MISO), 13 (SCK). These pins support SPI communication, which, although provided by the underlying hardware, is not currently included in the Arduino language.
- LED: 13. There is a built-in LED connected to digital pin 13. When the pin is HIGH value, the LED is on, when the pin is LOW, it's off.

The Pro Mini has 6 analog inputs, each of which provide 10 bits of resolution (i.e. 1024 different values). Four of them are on the headers on the edge of the board; two (inputs 4 and 5) on holes in the interior of the board. The analog inputs measure from ground to VCC. Additionally, some pins have specialized functionality:

There is another pin on the board:

- Reset. Bring this line LOW to reset the microcontroller. Typically used to add a reset button to shields which block the one on the board.

See also the mapping between Arduino pins and ATmega168 ports.

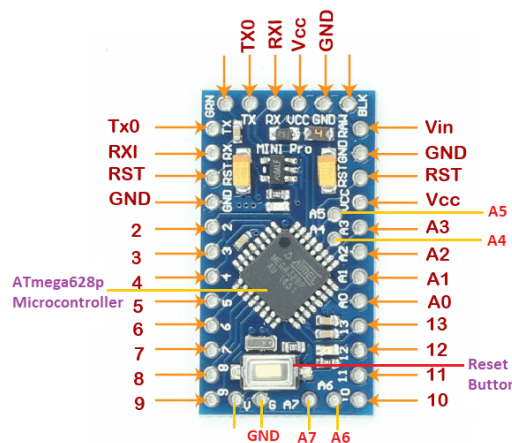

Figure 3.2: Arduino Pro Mini Pin Out

The high-performance Microchip PicoPower 8-bit AVR RISC-based microcontroller combines 32KB ISP flash memory with read-while-write capabilities, 1024B EEPROM,

2KB SRAM, 23 general purpose I/O lines, 32 general purpose working registers, three flexible timer/counters with compare modes, internal and external interrupts, serial programmable USART, a byte-oriented 2-wire serial interface, SPI serial port, a 6-channel 10-bit A/D converter (8-channels in TQFP and QFN/MLF packages), programmable watchdog timer with internal oscillator, and five software selectable power saving modes. The device operates between 1.8-5.5 volts. By executing powerful instructions in a single clock cycle, the device achieves throughput's approaching 1 MIPS per MHz, balancing power consumption and processing speed.

Microcontroller IC ATmega328p

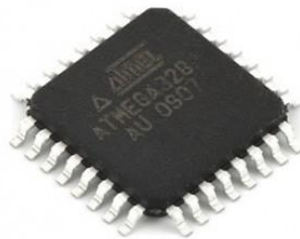

Figure 3.3: Microcontroller IC AT Mega 328p

3.3 Solar Panel

A solar panel is a set of solar photovoltaic modules electrically connected and mounted on a supporting structure. A photovoltaic module is a packaged, connected assembly of solar cells. The solar panel can be used as a component of a larger photovoltaic system to generate and supply electricity in commercial and residential applications. Each module is rated by its DC output power under standard test conditions (STC), and typically ranges from 100 to 320 watts. The efficiency of a module determines the area of a module given the same rated output - an 8% efficient 230-watt module will have twice the area of a 16% efficient 230-watt module. A single solar module can produce only a limited amount of power; most installations contain multiple modules. A photovoltaic system typically includes a panel or an array of solar modules, an inverter, and sometimes a battery and/or solar tracker and interconnection wiring.



Figure 3.4 : Solar Panel

Solar cell modules produce electricity only when the sun is shining. They do not store energy, therefore to ensure flow of electricity when the sun is not shining, it is necessary to store some of the energy produced. The most obvious solution is to use batteries, which chemically store electric energy. Batteries are groups of electro chemical cells (devices that convert chemical energy to electrical energy) connected in series. Battery cells are composed of two electrodes immersed in electrolyte solution which produce an electric current when a circuit is formed between them. The current is caused by reversible chemical reactions between the electrodes and the electrolyte within the cell. Batteries that are re-chargeable are called secondary or accumulator batteries. As the battery is being charged, electric energy is stored as chemical energy in the cells. When being discharged, the stored chemical energy is being removed from the battery and converted to electrical energy. In East-Africa, the most common type of secondary battery is the Lead-acid battery.

Specifications of Solar Panel

- Size: 4.4" x 5.4" / 110mm x 140mm
- Weight: 3 ounces / 90 grams
- Cell type: Monocrystalline
- Cell efficiency: 19%+
- 2.27 Watts Peak Power

- Technical drawing

3.4 Transistor

A transistor regulates current or voltage flow and acts as a switch or gate for electronic signals. A transistor consists of three layers of a semiconductor material, each capable of carrying a current. A semiconductor is a material such as germanium and silicon that conducts electricity in a "semi-enthusiastic" way.

Specifications:

- Bipolar Transistor, npn, 45v, to-92
- Transistor Polarity: NPN
- Collector Emitter Voltage $V_{(br)ceo}$: 45V
- Transition Frequency Typ ft: 300MHz
- Power Dissipation Pd: 625mW
- DC Collector Current: 100mA
- DC Current Gain hFE: 150
- Straight-lead housing

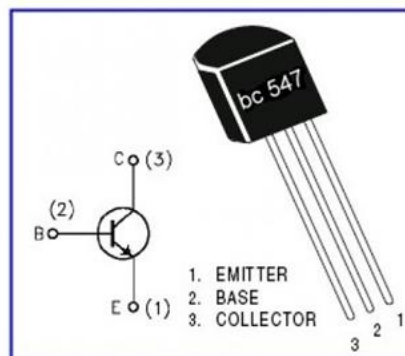

Figure 3.5: BC 547

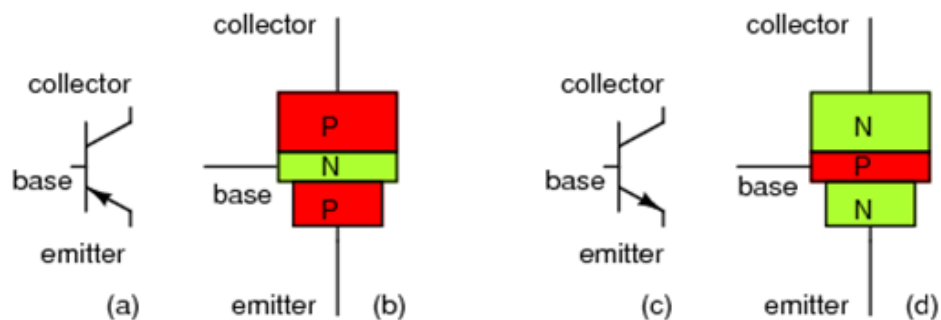

Figure 3.6: Transistor Symbols

My intent here is to focus as exclusively as possible on the practical function and application of bipolar transistors, rather than to explore the quantum world of semiconductor theory. Discussions of holes and electrons are better left to another chapter in my opinion. Here I want to explore how to use these components, not analyze their intimate internal details. I don't mean to downplay the importance of understanding semiconductor physics, but sometimes an intense focus on solid-state physics detracts from understanding these devices' functions on a component level. In taking this approach, however, I assume that the reader possesses a certain minimum knowledge of semiconductors: the difference between "P" and "N" doped semiconductors, the functional characteristics of a PN (diode) junction, and the meanings of the terms "reverse biased" and "forward biased." If these concepts are unclear to you, it is best to refer to earlier chapters in this book before proceeding with this one. A bipolar transistor consists of a three-layer "sandwich" of doped (extrinsic) semiconductor materials, either P-N-P in Fig below a(b) or N-P-N at (d). Each layer forming the transistor has a specific name, and each layer is provided with a wire contact for connection to a circuit. The schematic symbols are shown in Fig below (a) and (d).

BJT transistor: (a) PNP schematic symbol, (b) physical layout (c) NPN symbol, (d) layout.

The functional difference between a PNP transistor and an NPN transistor is the proper biasing (polarity) of the junctions when operating. For any given state of operation, the current directions and voltage polarities for each kind of transistor are exactly opposite each other. Bipolar transistors work as current-controlled current regulators. In other words, transistors restrict the amount of current passed according to a smaller, controlling current. The main current that is controlled goes from collector to emitter, or from emitter to collector, depending on the type of transistor it is (PNP or NPN, respectively). The small current that controls the main current goes from base to emitter, or from emitter to base, once again depending on the kind of transistor it is (PNP or NPN, respectively). According to the standards of semiconductor symbology, the arrow always points against the direction of electron flow. (Fig below)

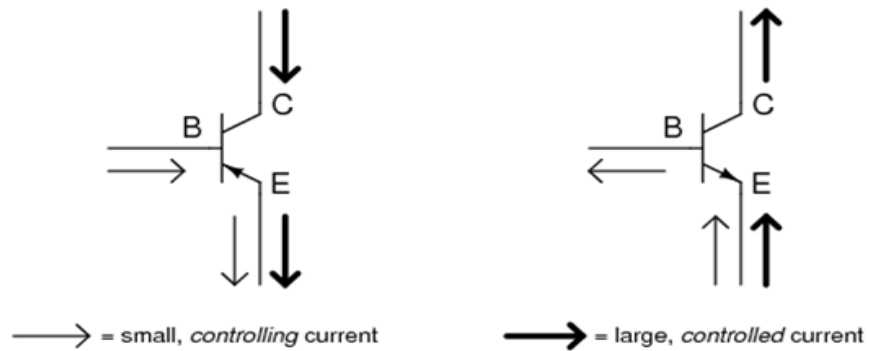

Figure 3.7: NPN & PNP Transistor Symbol

Small Base-Emitter current controls large Collector-Emitter current flowing against emitter arrow. Bipolar transistors are called bipolar because the main flow of electrons through them takes place in two types of semiconductor material: P and N, as the main current go from emitter to collector (or vice versa). In other words, two types of charge carriers—electrons and holes—comprise this main current through the transistor.

As you can see, the controlling current and the controlled current always mesh together through the emitter wire, and their electrons always flow against the direction of the transistor's arrow. This is the first and foremost rule in the use of transistors: all currents must be going in the proper directions for the device to work as a current regulator. The small, controlling current is usually referred to simply as the base current because it is the only current that goes through the base wire of the transistor. Conversely, the large, controlled current is referred to as the collector current because it is the only current that goes through the collector wire. The emitter current is the sum of the base and collector currents, in compliance with Kirchhoff's Current Law. No current through the base of the transistor, shuts it off like an open switch and prevents current through the collector. A base current, turns the transistor on like a closed switch and allows a proportional amount of current through the collector. Collector current is primarily limited by the base current, regardless of the amount of voltage available to push it.

3.5 Resistor

Resistors are electronic components which have a specific, never-changing electrical resistance. The resistor's resistance limits the flow of electrons through a circuit. They are passive components, meaning they only consume power (and can't generate it). Resistors are usually added to circuits where they complement active components like op-amps,

micro-controllers, and other integrated circuits. Commonly resistors are used to limit current, divide voltages, and pull-up I/O lines.

The electrical resistance of a resistor is measured in ohms. The symbol for an ohm is the greek capital-omega: Ω . The (somewhat roundabout) definition of 1Ω is the resistance between two points where 1 volt (1V) of applied potential energy will push 1 ampere (1A) of current. As SI units go, larger or smaller values of ohms can be matched with a prefix like kilo-, mega-, or giga-, to make large values easier to read. It's very common to see resistors in the kilohm ($k\Omega$) and megaohm ($M\Omega$) range (much less common to see miliohm ($m\Omega$) resistors). For example, a $4,700\Omega$ resistor is equivalent to a $4.7k\Omega$ resistor, and a $5,600,000\Omega$ resistor can be written as $5,600k\Omega$ or (more commonly as) $5.6M\Omega$. All resistors have two terminals, one connection on each end of the resistor. When modeled on a schematic, a resistor will show up as one of these two symbols:

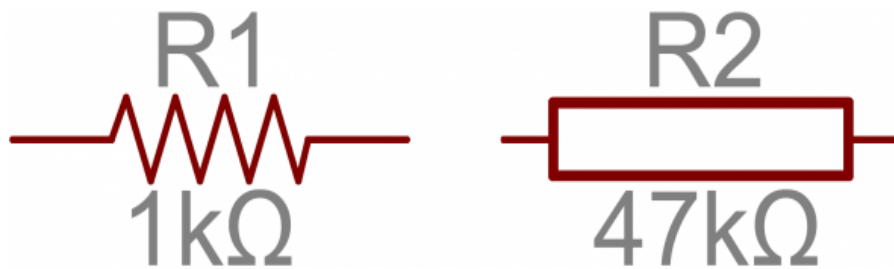

Figure 3.8: Two common resistor schematic symbols

3.6 Battery

Lithium batteries are primary batteries that have metallic lithium as an anode. These types of batteries are also referred to as lithium-metal batteries. They stand apart from other batteries in their high charge density and high cost per unit. Depending on the design and chemical compounds used, lithium cells can produce voltages from 1.5 V (comparable to a zinc-carbon or alkaline battery) to about 3.7 V.

Disposable primary lithium batteries must be distinguished from secondary lithium-ion or a lithium-polymer,^[1] which are rechargeable batteries. Lithium is especially useful, because its ions can be arranged to move between the anode and the cathode, using an intercalated lithium compound as the cathode material but without using lithium metal

as the anode material. Pure lithium will instantly react with water, or even moisture in the air; the lithium in lithium ion batteries is in a less reactive compound.



Figure 3.9: 3.7V Battery

Lithium batteries are widely used in portable consumer electronic devices. The term "lithium battery" refers to a family of different lithium-metal chemistry, comprising many types of cathodes and electrolytes but all with metallic lithium as the anode. The battery requires from 0.15 to 0.3 kg of lithium per kWh. As designed these primary systems use a charged cathode, that being an electro-active material with crystallographic vacancies that are filled gradually during discharge.

Product Specification

Voltage	3.7 V
Product Type	Lithium-Ion
Battery Capacity	2200mAh
Weight	45 g
Model Number	ICR 18650

3.7 5V Regulator IC

Voltage sources in a circuit may have fluctuations resulting in not providing fixed voltage outputs. A voltage regulator IC maintains the output voltage at a constant value. 7805 IC, a member of 78xx series of fixed linear voltage regulators used to maintain such fluctuations, is a popular voltage regulator integrated circuit (IC). The xx in 78xx indicates the output voltage it provides. 7805 IC provides +5 volts regulated power supply with provisions to add a heat sink.

7805 IC Rating

- Input voltage range 7V- 35V
- Current rating IC = 1A
- Output voltage range $V_{Max}=5.2V$, $V_{Min}=4.8V$

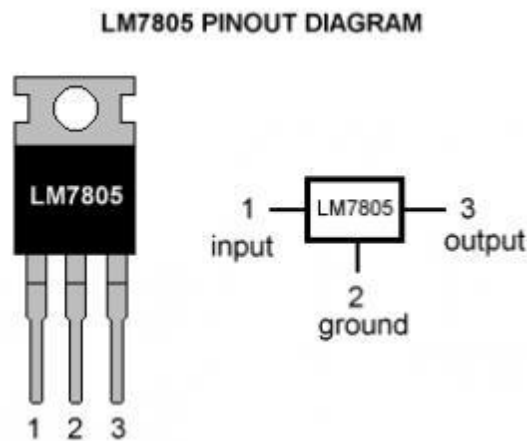

Figure 3.10: 5V Regulator IC

3.8 LDR

The LDR Sensor Module is used to detect the presence of light / measuring the intensity of light. The output of the module goes high in the presence of light and it becomes low in the absence of light. The sensitivity of the signal detection can be adjusted using potentiometer.

Features:

- Adjustable sensitivity (via blue digital potentiometer adjustment)
- Operating voltage 3.3V-5V
- Output Type: Analog voltage output -A0
- Digital switching outputs (0 and 1) -D0
- With fixed bolt hole for easy installation
- Small board PCB size: 3cm * 1.6cm
- Power indicator (red) and the digital switch output indicator (green)
- Using LM393 comparator chip, stable

Pin outs:

- External 3.3V-5V VCC
- External GND GND
- DO digital output interface, a small plate (0 and 1)
- AO small board analog output interface
- Can detect ambient brightness and light intensity

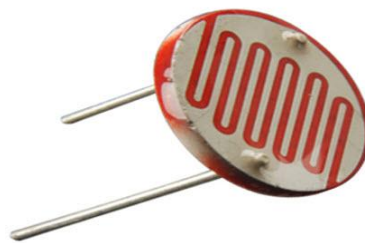

Figure 3.11: LDR

3.9 Arduino Software

The digital micro-controller unit named as Arduino Nano can be programmed with the Arduino software IDE. There is no any requirement for installing other software rather than Arduino. Firstly, Select "Arduino Nano from the Tools, Board menu (according to the micro-controller on our board). The IC used named as ATmega328 on the Arduino Nano

comes pre burned with a boot loader that allows us to upload new code to it without the use of an external hardware programmer.

Communication is using the original STK500 protocol (reference, C header files). We can also bypass the boot loader and programs the micro-controller through the ICSP (In Circuit Serial Programming) header. The ATmega16U2 (or 8U2 in the rev1 and rev2 boards) firmware source code is available. The ATmega16U2/8U2 is loaded with a DFU boot loader, which can be activated by:

On Rev1 boards: connecting the solder jumper on the back of the board (near the map of Italy) and then resetting the 8U2. On Rev2 or later boards: there is a resistor that pulling the 8U2/16U2 HWB line to ground, making it easier to put into DFU mode. The Arduino Nano is one of the latest digital micro-controller units and has a number of facilities for communicating with a computer, another Arduino, or other micro-controllers. The ATmega328 provides UART TTL at (5V) with serial communication, which is available on digital pins 0 -(RX) for receive the data and pin no.1 (TX) for transmit the data. An ATmega16U2 on the board channels this serial communication over USB and appears as a virtual com port to software on the computer. The '16U2 firmware uses the standard USB COM drivers, and no external driver is needed. However, on Windows, an .in file is required. The Arduino software includes a serial monitor which allows simple textual data to be sent to and from the Arduino board.

The RX and TX LEDs on the board will flash when data is being transmitted via the USB-to-serial chip and USB connection to the computer (but not for serial Communication on pins 0 and 1). A Software Serial library allows for serial communication on any of the Nano's digital pins. The ATmega328 also supports I2C (TWI) and SPI communication. The Arduino software includes a Wire library to simplify use of the I2C bus. Arduino programs are written in C or C++ and the program code written for Arduino is called sketch.

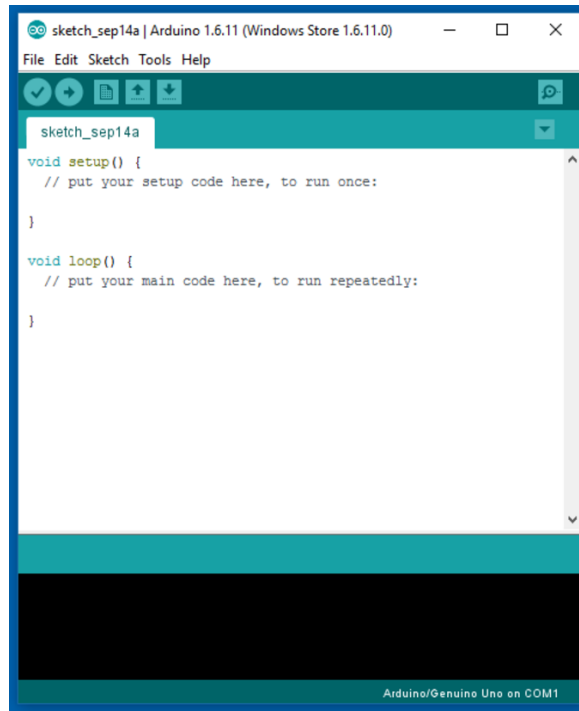

Figure 3.12: Arduino Software Interface IDE

The Arduino IDE uses the GNU tool chain and AVR Lab to compile programs, and for uploading the programs it uses avrdude. As the Arduino platform uses Atmel micro-controllers, Atmel's development environment, AVR Studio or the newer Atmel Studio, may also be used to develop software for the Arduino. The Arduino Integrated Development Environment - or Arduino Software (IDE) - contains a text editor for writing code, a message area, a text console, a toolbar with buttons for common functions and a series of menus. It connects to the Arduino and Genuino hardware to upload programs and communicate with them.

Writing Sketches

Programs written using Arduino Software (IDE) are called sketches. These sketches are written in the text editor and are saved with the file extension .ino. The editor has features for cutting/pasting and for searching/replacing text. The message area gives feedback while saving and exporting and also displays errors. The console displays text

Sketchbook

The Arduino Software (IDE) uses the concept of a sketchbook: a standard place to store your programs (or sketches). The sketches in your sketchbook can be opened from the File > Sketchbook menu or from the Open button on the toolbar. The first time you run the Arduino software, it will automatically create a directory for your sketchbook. You can view or change the location of the sketchbook location from with the Preferences dialog.

Beginning with version 1.0, files are saved with a .ino file extension. Previous versions use the .pde extension. You may still open .pde named files in version 1.0 and later, the software will automatically rename the extension to .ino.

Tabs, Multiple Files, and Compilation

Allows you to manage sketches with more than one file (each of which appears in its own tab). These can be normal Arduino code files (no visible extension), C files (.c extension), C++ files (.cpp), or header files (.h).

Uploading

Before uploading your sketch, you need to select the correct items from the Tools > Board and Tools > Port menus. The boards are described below. On the Mac, the serial port is probably something like /dev/tty.usbmodem241 (for an Uno or Mega2560 or Leonardo) or /dev/tty.usbserial-1B1 (for a Duemilanove or earlier USB board), or /dev/tty.USA19QW1b1P1.1 (for a serial board connected with a Keyspan USB-to-Serial adapter). On Windows, it's probably COM1 or COM2 (for a serial board) or COM4, COM5, COM7, or higher (for a USB board) - to find out, you look for USB serial device in the ports section of the Windows Device Manager. On Linux, it should be /dev/ttyACMx , /dev/ttyUSBx or similar. Once you've selected the correct serial port and board, press the upload button in the toolbar or select the Upload item from the Sketch menu. When you upload a sketch, you're using the Arduino boot loader, a small program that has been loaded on to the micro-controller on your board. It allows you to upload code without using any additional hardware. The boot-loader is active for a few seconds when the board resets; then it starts whichever sketch was most recently uploaded to the micro-controller. The boot loader will blink the on-board (pin 13) LED when it starts (i.e. when the board resets).

Libraries

Libraries provide extra functionality for use in sketches, e.g. working with hardware or manipulating data. To use a library in a sketch, select it from the Sketch > Import Library menu. This will insert one or more `#include` statements at the top of the sketch and compile the library with your sketch. Because libraries are uploaded to the board with your sketch, they increase the amount of space it takes up. If a sketch no longer needs a library, simply delete its `#include` statements from the top of your code.

There is a list of libraries in the reference. Some libraries are included with the Arduino software. Others can be downloaded from a variety of sources or through the Library Manager. Starting with version 1.0.5 of the IDE, you do can import a library from a zip file and use it in an open sketch. See these instructions for installing a third-party library.

Third-Party Hardware

Support for third-party hardware can be added to the hardware directory of your sketchbook directory. Platforms installed there may include board definitions (which appear in the board menu), core libraries, boot loaders, and programmer definitions. To install, create the hardware directory, then unzip the third-party platform into its own sub-directory. (Don't use "arduino" as the sub-directory name or you'll override the built-in Arduino platform.) To uninstall, simply delete its directory.

3.10 Easy EDA Software

EasyEDA is a web-based EDA tool suite that enables hardware engineers to design, simulate, share - publicly and privately - and discuss schematics, simulations and printed circuit boards. Other features include the creation of a bill of materials, Gerber files and pick and place files and documentary outputs in PDF, PNG and SVG formats. EasyEDA allows the creation and editing of schematic diagrams, SPICE simulation of mixed analogue and digital circuits and the creation and editing of printed circuit board layouts and, optionally, the manufacture of printed circuit boards.

Subscription-free membership is offered for public plus a limited number of private projects. The number of private projects can be increased by contributing high quality

public projects, schematic symbols, and PCB footprints and/or by paying a monthly subscription. Registered users can download Gerber files from the tool free of charge; but for a fee, EasyEDA offers a PCB fabrication service. This service is also able to accept Gerber file inputs from third party tools.

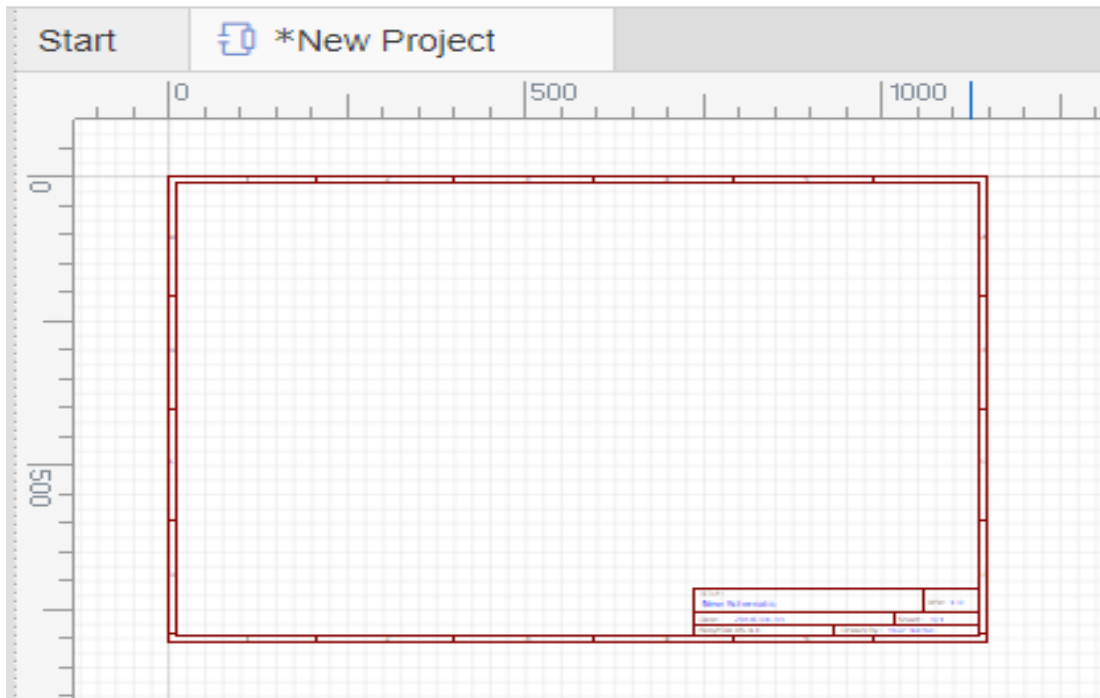

Figure 3.13: EasyEDA Software Interface

3.11 Temperature Sensor

The DHT11 is a basic, ultra-low-cost digital temperature and humidity sensor. It uses a capacitive humidity sensor and a thermistor to measure the surrounding air, and spits out a digital signal on the data pin (no analog input pins needed). It's fairly simple to use, but requires careful timing to grab data.

DHT11 Specifications:

- Operating Voltage: 3.5V to 5.5V
- Operating current: 0.3mA (measuring) 60uA (standby)
- Output: Serial data

- Temperature Range: 0°C to 50°C
- Humidity Range: 20% to 90%
- Resolution: Temperature and Humidity both are 16-bit
- Accuracy: $\pm 1^\circ\text{C}$ and $\pm 1\%$

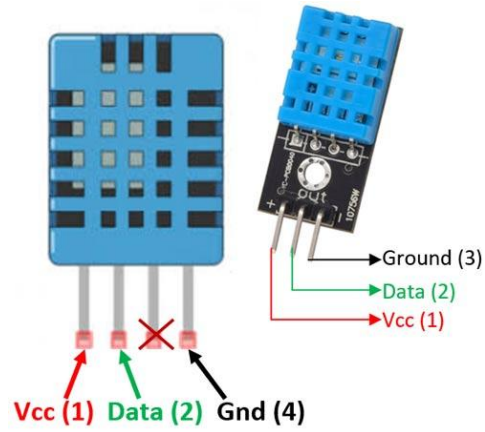

Figure 3.14: DHT11 Temperature Sensor

CHAPTER 4

THE DESIGN METHODS AND PROCEDURES

4.1 Methodology

- In this project we use a solar panel for primary power source. Here also use an Arduino Pro Mini, LDR Sensor, Servo Motor and 7.4V Battery.
- This solar panel detects sunlight automatically built-in LDR sensor, an LDR sensor operated by the micro-controller (Arduino Pro mini). This micro-controller also operates a servo motor to rotate solar panels horizontally and vertically. The main work of this project is when the sun is incident in the solar panel then it will charge and store in a 7.4v battery. Then we use a buck converter to convert 7.4v to 5v for operating the micro-controller. this micro-controller runs on a 5 DC volt.
- We have experimented with 3 types of solar panels to compare efficiency, namely normal axis, single axis, and dual axis solar panels.
- On the normal axis, we keep the dual and single axis closed and the solar panel fixed. We used 18 watts of intensity as input. We measured the output from our solar panel after certain minutes with a multimeter. We take data until our rechargeable battery is 0-100% charged. By recording that data from there we are able to get the average output of a normal solar axis. And finally, we get efficiency from the normal solar axis.
- On a single axis, we were able to get an average output using 18 watts of intensity with the solar system in one-axis mode. And finally, we got comparatively more efficiency than the normal axis.
- Similarly, in the dual axis, we used an 18-watt intensity and determined the data by a multi meter after a certain time. Compared to the normal axis and single axis, we got a higher average output on the dual axis. And finally, from the dual axis, we are able to get comparatively more efficiency.

4.2 Block Diagram

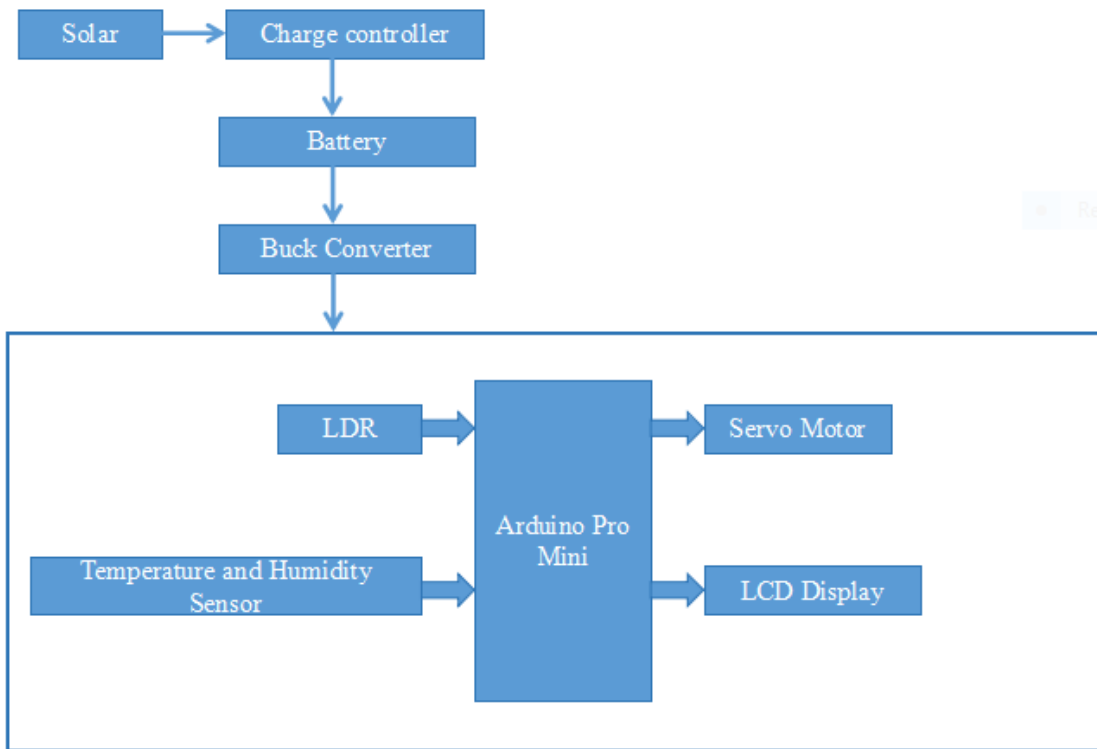

Figure 4.1: Block Diagram of our Project

4.3 Schematic Diagram

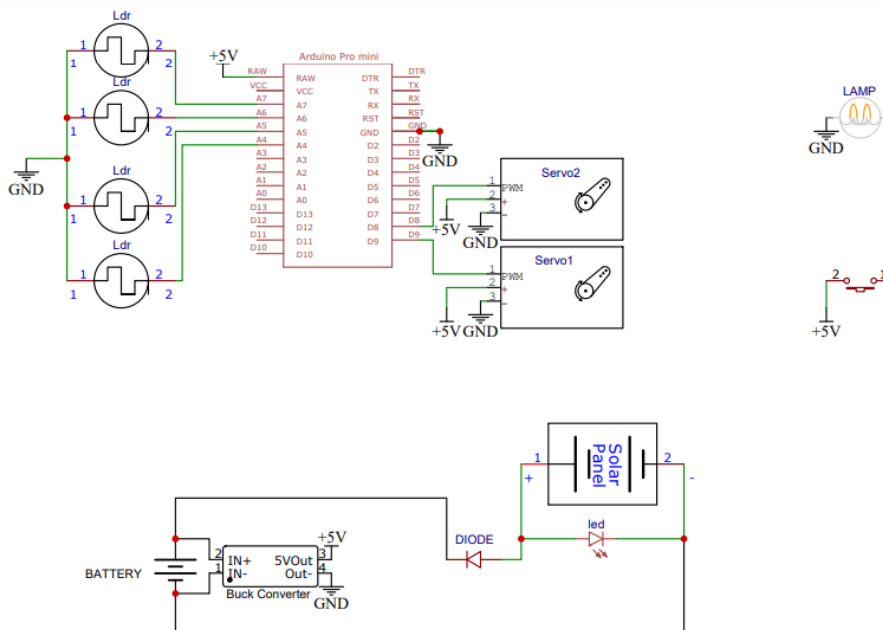

Figure 4.2: Circuit Diagram of Our System

4.4 Working Principle

In this project, we use a 6v solar panel as a primary power source. This solar panel detects sunlight automatically built-in LDR sensor, an LDR sensor operated by the micro-controller (Arduino Pro mini). This micro-controller also operates a servo motor to rotate solar panels horizontally and vertically. The main work of this project is when the sun is incident in the solar panel then it will charge and store in a 7.4v battery. Then we use a buck converter to convert 7.4v to 5v for operating the micro-controller. this micro-controller runs on a 5 DC volt. Finally, we added a single feature light that runs on DC current.

4.5 Project Prototype Image



Figure 4.3: Our Final Project Prototype

4.6 Project Cost Analysis

Table 02: Required Instrument Cost Analysis

Sl. No	Particulars	Specification	Qty.	Unit Price (Taka)	Total Price (Taka)
01	Arduino	Pro Mini	1	580	580
02	Solar Panel	5Watt	1	450	450
03	Buck Converter	LM2596	1	130	130
04	Battery	3.7V	2	100	200
05	Servo Motor	MG996R	2	400	800
06	LDR	5V	4	10	40
07	Others				1860
				Total	4060/=

CHAPTER 5

RESULTS AND DISCUSSION

5.1 Result

- Finally, we have completed our project successfully & check our project its run accurately according to our objective.
- At first, we start our system.
- After project on LDR sensor detect the sunlight direction and move accordingly.
- Solar Panel Store charge in battery. And DC load is on.

Data Table

STATIONARY/NORMAL SOLAR SYSTEM					
SL No.	Time	Battery Charge	Solar Volt(watt)	Ampere	Pout(volt*amp)
1	After 14 min	0.25v	0.855w	0.30A	0.256w
2	28 min	0.50v	0.957w	0.33A	0.315w
3	42min	0.75v	1.03w	0.35A	0.361w
4	56min	1.0v	0.90w	0.31A	0.278w
5	70min	1.25v	0.78w	0.27A	0.210w
6	84 min	1.5v	0.976w	0.33A	0.322w
7	112 min	2.0v	1.14w	0.38A	0.434w
8	140 min	2.5v	1.21w	0.42A	0.511w
9	168 min	3.0v	1.48w	0.49A	0.72w
10	196 min	3.5v	1.386w	0.45A	0.623w
11	224 min	4.0v	1.28w	0.41A	0.524w
12	252 min	4.5v	1.575w	0.50A	0.787w
13	280 min	5.0v	1.76w	0.55A	0.97w
14	308 min	5.5v	1.67w	0.52A	0.870w
15	336 min	6.0v	1.86w	0.57A	1.05w

16	364 min	6.5v	1.935w	0.59A	1.414w
17	378 min	6.75v	1.98w	0.60A	1.188w
18	392 min	7.0v	2.158w	0.65A	1.40w
19	406 min	7.25v	2.108w	0.62A	1.306w
20	415 min	7.4v	2.03w	0.58A	1.177w

□ **Average Pout = 14.437/20 = 0.721W**

SINGLE AXIS SOLAR TRACKER					
SL No.	Time	Battery Charge	Solar Volt(watt)	Ampere	Pout(volt*amp)
1	After 5 min	0.1v	1.152w	0.36A	0.414w
2	25 min	0.5v	1.306w	0.42A	0.548w
3	50 min	1.0v	1.212w	0.38A	0.46w
4	75 min	1.5v	1.14w	0.35A	0.399w
5	100 min	2.0v	1.32w	0.40A	0.528w
6	125 min	2.5v	1.512w	0.42A	0.635w
7	150 min	3.05v	1.62w	0.48A	0.78w
8	175 min	3.50v	1.47w	0.44A	0.64w
9	200 min	4.0v	1.82w	0.52A	0.9464w
10	225 min	4.45v	2.017w	0.57A	1.15w
11	250 min	4.95v	2.13w	0.59A	1.25w
12	275 min	5.50v	2.485w	0.67A	1.664w
13	300 min	6.0v	2.59w	0.70A	1.81w
14	325 min	6.5v	2.597w	0.68A	1.765w
15	350 min	7.0v	3.081w	0.79A	2.43w
16	370 min	7.4v	3.157w	0.82A	2.58w

□ **Pout Average = 17.99/16 = 1.124W**

DUAL AXIS SOLAR TRACKER					
SL No.	Time	Battery Charge	Solar Volt(watt)	Ampere	Pout(volt*amp)
1	After 10 min	0.4v	2.33w	0.58A	1.351w
2	20 min	0.8v	2.41w	0.60A	1.446w
3	30 min	1.2v	2.132w	0.52A	1.108w
4	40 min	1.6v	1.7w	0.40A	0.68w
5	50 min	2.0v	1.88w	0.44A	0.827w
6	60 min	2.4v	2.44w	0.56A	1.366w
7	70 min	2.8v	3.03w	0.70A	2.121w
8	80 min	3.2v	3.18w	0.72A	2.28w
9	90 min	3.6v	2.97w	0.66A	1.96w
10	100 min	4.0v	2.68w	0.58A	1.554w
11	110 min	4.6v	2.596w	0.55A	1.4278w
12	120 min	5.0v	2.35w	0.49A	1.1515w
13	130 min	5.4v	2.64w	0.54A	1.425w
14	140 min	5.8v	2.92w	0.60A	1.752w
15	150 min	6.2v	3.81w	0.79A	3.009w
16	160 min	6.8v	3.68w	0.77A	2.833w
17	170 min	7.0v	4.06w	0.82A	3.32w
18	180 min	7.4v	4.14w	0.89A	3.684w

□ **Average Pout = 33.2953/18 =1.85W**

5.2 Equation

Stationary/Normal Axis Efficiency

$$\begin{aligned}\eta &= P_{out} / P_{in} \times 100\% \\ &= 0.721/18 * 100\% \\ &= 4.0\%\end{aligned}$$

Here,

$$\begin{aligned}P_{in} &= 18W \\ P_{out} &= 0.721W\end{aligned}$$

Single Axis Efficiency

$$\begin{aligned}\eta &= P_{out} / P_{in} * 100\% \\ &= 1.124/18 * 100\% \\ &= 6.24\%\end{aligned}$$

Here,

$$\begin{aligned}P_{in} &= 18W \\ P_{out} &= 1.124W\end{aligned}$$

Dual Axis Efficiency

$$\begin{aligned}\eta &= P_{out} / P_{in} * 100\% \\ &= 1.85/18 * 100\% \\ &= 10.27\%\end{aligned}$$

Here,

$$\begin{aligned}P_{in} &= 18W \\ P_{out} &= 1.85W\end{aligned}$$

5.3 Graph:

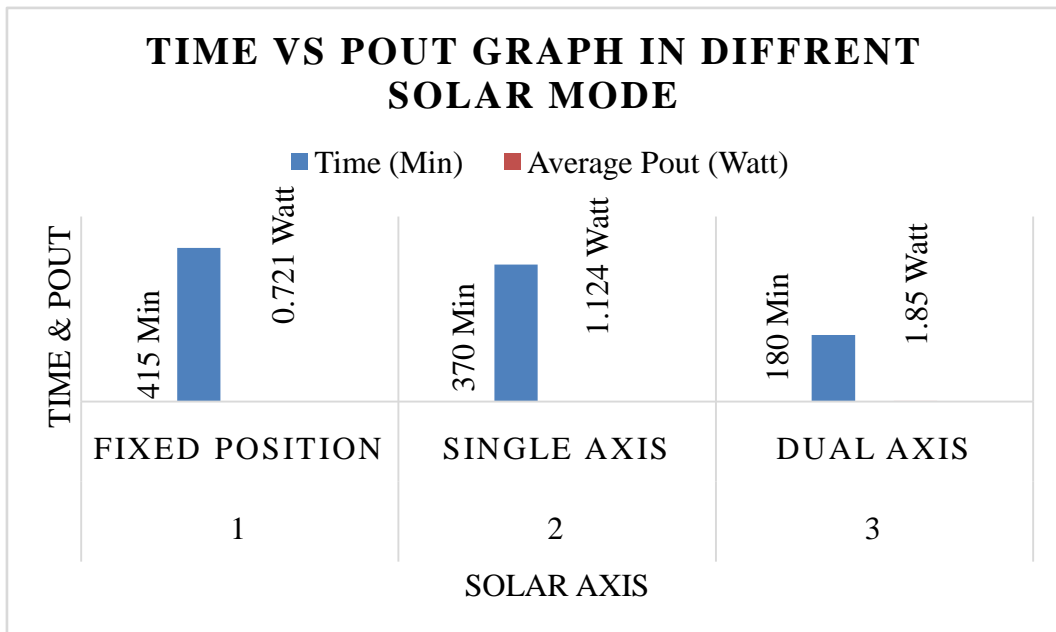

Figure 5.1: Time vs Pout Graph in Different Solar Mode

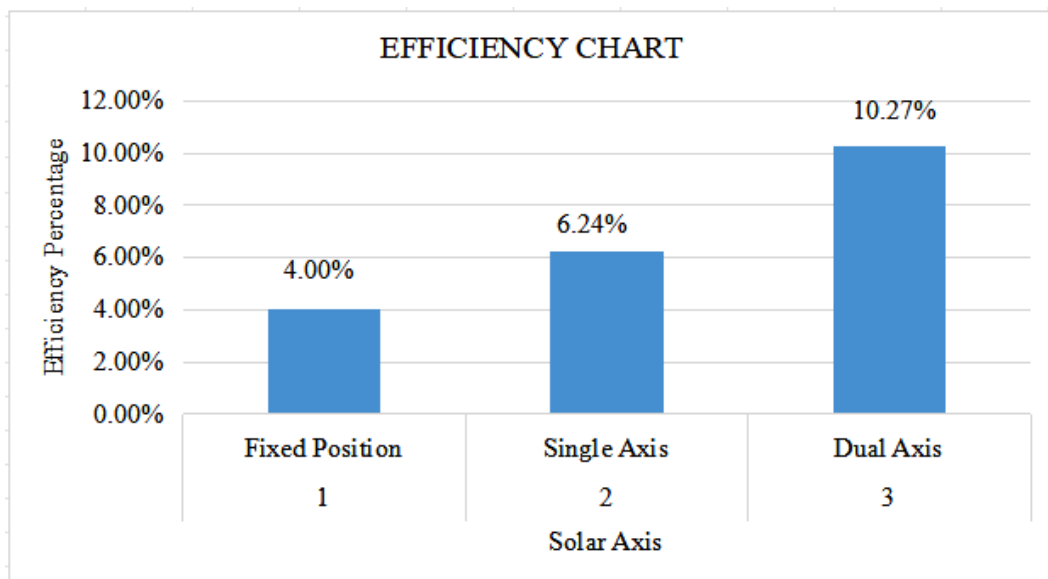

Figure 5.2: Efficiency Graph

5.4 Advantages

There are certainly many advantages of our project and some of the major ones have been given below:

- The power sources are natural and the battery is rechargeable.
- Less power consumption with best utilization.
- The whole system is automatic and saves energy by detecting the presence of light.
- The system is user friendly.
- The system is good for the environment as it utilizes renewable energy sources.

5.5 Application

Our project has many application areas and actually we need to use it in many places to verified the exact person which have the proper access. Some of the application areas of the project has been pointed out below:

- The system can be implemented to work on different projects.
- It can be implemented in area where power wastage takes place a lot.
- It can be implemented in areas where there's power shortage.
- This system can work to power almost anything that runs on electricity

5.6 Limitation

Although our project has many applications and advantages but there are some limitations of the project as well and the good thing is that these limitations are minor and doesn't affect the efficiency of the system. Limitations are given below:

- The system needs to be more efficient to produce more energy.
- Due to using renewable energy sources, electrical energy production is less and most of the energy is not converted rather wasted.
- On rainy days, foggy weather and some problems may occur which can hamper energy production.

- Since the input power (18W light) is relatively large from the solar panel, the maximum power is spread around, so the solar panel is not able to absorb its desired power, so we do not get proper efficiency

5.7 Discussion

While working on our project, we did face some difficulties as it is a very complex system but the end results, we came up with were quite satisfactory. We have put the whole system through several tasks to validate our work and also have taken necessary notes for future improvements. Some future recommendations that we have involves improvement in system design and wiring, adding features for more efficient.

CHAPTER 6

CONCLUSION

6.1 Conclusion

We presented a means of dual axis solar tracking system continually orient PV panels towards the sun with the help of Microcontroller, LDR sensor, and Servo Motor in the PV system. Average power gain of dual axis solar tracker. In the long run this project will be beneficial, and sustainable for water bodies area. Dual axis PV system provide the reasonable solution for limited land resource and creating clean and emission free power generation.

6.2 Future Scope

We are thinking about adding many features to our project in the future to get more desirable outcomes. Some of the steps that we are thinking about taking are given below:

- In the future we are looking forward to improved of our whole system design to make it more efficient.
- In the future this tilting mechanism with a collector can be implemented on large solar plants and also can be operated automatically.
- This mechanism can be implemented on solar cookers, ovens, carriers and on thermal solar heaters.

Reference

- [1] “A low-cost dual-axis solar tracking system based on digital logic design: Design and implementation” by ChaowanJamroen, Preecha Komkum, Sompol Kohsri, WuttinanHimananto, SiriwatPanupintu, Sorawit Unkat.
- [2] “Design and fabrication of microcontroller-based dual axis light-sensitive rotating solar panel” by Md. Rezwan Munshi, Faisal Hussain, Farzana Bristi, S. Kumer Karmoker, Z.M. Zefat& F. Begum Sumu.
- [3] “Design and development of dual axis sun tracking system for floating PV plant” Sendhil Kumar Natarajan, Aman Kumar, Raqeeb Mohamed, Rathna R, Swaraj Mondal and SubbaramaKousikSuraparaju.
- [4] “A Review on Floating Photovoltaic Technology (FPVT)” by Hasnain Yousuf, Muhammad Quddamah Khokhar, Muhammad Aleem Zahid, Jaeun Kim, Youngkuk Kim, Eun-Chel Cho, Young Hyun Cho.
- [5] Ying-Tung Hsiao, China-Hong Chen, “Maximum Power Tracking for Photovoltaic Power System,” Conference Record of the 2002 IEEE Industry Applications Conference. 37th IAS Annual Meeting, ISBN- 0-7803-7420-7, 13-18 Oct, 2002, pp 1035-1039.
- [6] Mayank Kumar Lokhande, “Automatic Solar Tracking System,” International Journal of Core Engineering & Management, October, 2014.
- [7] Scott J Hamilton, “Sun-Tracking Solar Cell Array System,” University of Queensland, Department of Electrical Engineering, 1999
- [8] Furkan Dincer, Mehmet Emin Meral, “Critical Factors that Affecting Efficiency of Solar Cell,” University ofYuzuncuYil, Department of Electrical and Electronics Engineering, Van, Turkey, 2010.

- [9] R.Z. Wang, T.S. Ge, “Advances in Solar Heating and Cooling,” Woodhead Publishing, 2016, Pages 81- 93, ISBN 9780081003015,
- [10] Levent Bas, “Thin Film vs. Crystalline Silicon PV Modules,” December, 2011.
- [11] M. A. Panait, T. Tudorache, “A Simple Neural Network Solar Tracker for Optimizing Conversion Efficiency in Off-Grid Solar Generators”, International Conference on Renewable energies and Power quality (ICREPQ), march 12-14, Santander, 2008.
- [12] Juan Reca-Cardena, Rafael López-Luque, Chapter 9- Design Principles of Photovoltaic Irrigation Systems, “Advances in Renewable Energies and Power Technologies”, Elsevier Science, 2018
- [13] C. Chang, Chapter 5 Tracking solar collection technologies for solar heating and cooling systems, “Advances in Solar Heating and Cooling”, Woodhead Publishing, 2016
- [14] Kamrul Islam Chowdhury, Md.Iftekhari-ul-Alam, Promit Shams Bakshi, “Performance Comparison Between Fixed Panel, Single-axis and Dual-axis Sun Tracking Solar Panel System,” BRAC University, Department of Electrical and Electronic Engineering, 2017.

Appendix

Micro-Controller Programming Code:

```
#include <Servo.h>
#include <Wire.h>

float input_voltage = 0.0;
float temp=0.0;

float input_voltage1 = 0.0;
float temp1=0.0;

// horizontal servo
Servo horizontal;
int servoh = 90;
int servohLimitHigh = 180;
int servohLimitLow = 0;

Servo vertical;
int servov = 90;
int servovLimitHigh = 180;
int servovLimitLow = 0;

// LDR pin connections
int ldrTR = A3; // LDR top right
int ldrTL = A2; // LDR top left
int ldrBR = A1; // LDR bottom right
int ldrBL = A0; // LDR bottom left

/*// LDR pin connections
int ldrTR = A2; // LDR top right
int ldrTL = A3; // LDR top left
```

```

int ldrBR = A0; // LDR bottom right
int ldrBL = A1; // LDR bottom left
*/

int dtime ; // change for debugging only
int tol ;

int avt ; // average value top
int avd ; // average value bottom
int avl ; // average value left
int avr ; // average value right

int dvert; // check the difference of up and down
int dhoriz; // check the difference of left and right
int tr ; // top right
int tl ; // top left
int br ; // bottom right
int bl ; // bottom left

int analog_value ;
int analog_value1 ;
float t1 ;

void setup() {
  // put your setup code here, to run once:
  Serial.begin(9600);

  pinMode(A6,INPUT);
  horizontal.attach(10);
  vertical.attach(9);
  // move servos
  horizontal.write(50);

```



```

vertical.write(50);
delay(500);
}

void loop() {
  // put your main code here, to run repeatedly:
  int tr = analogRead(ldrTR); // top right
  int tl = analogRead(ldrTL); // top left
  int br = analogRead(ldrBR); // bottom right
  int bl = analogRead(ldrBL); // bottom left
  //int analog_value = analogRead(A6);
  //int analog_value1 = analogRead(A7);    ///solar voltage print
  //input_voltage = (analog_value * 8.0) / 1024.0;
  //input_voltage1 = (analog_value1 * 5.0) / 1024.0;
  //float batteryvoltage = input_voltage1*8;
  //lcd.setCursor(0, 0);
  //lcd.print("Solar: ");
  //lcd.setCursor(6, 0);
  //lcd.print(input_voltage   );

  tr = analogRead(ldrTR); // top right
  tl = analogRead(ldrTL); // top left
  br = analogRead(ldrBR); // bottom right
  bl = analogRead(ldrBL); // bottom left

  dtime = 0; // change for debugging only
  tol = 50;

  avt = (tl + tr) / 2; // average value top
  avd= (bl + br) / 2; // average value bottom
  avl = (tl + bl) / 2; // average value left
  avr = (tr + br) / 2; // average value right

```

```

dvert = avt - avd; // check the difference of up and down
dhoriz = avl - avr; // check the difference of left and right
Serial.print(tl);
Serial.print(" ");
Serial.print(tr);
Serial.print(" ");
Serial.print(bl);
Serial.print(" ");
Serial.print(br);
Serial.print(" ");
Serial.print(avt);
Serial.print(" ");
Serial.print(avd);
Serial.print(" ");
Serial.print(avl);
Serial.print(" ");
Serial.print(avr);
Serial.print(" ");
Serial.print(dtime);
Serial.print(" ");
Serial.print(tol);
Serial.print(" ");
Serial.print(servov);
Serial.print(" ");
Serial.print(servoh);
Serial.println(" ");

    if (-1 * tol > dvert || dvert > tol) {
if (avt > avd) {
servov = ++servov;
    if (servov > servovLimitHigh) {
servov = servovLimitHigh;
    }

```

```

    }
    else if (avt<avd) {
servov = --servov;
        if (servov<servovLimitLow) {
servov = servovLimitLow;
        }
    }
vertical.write(servov);
}

if (-1 * tol>dhoriz || dhoriz>tol) {
if (avl>avr) {
servoh = --servoh;
    if (servoh<servohLimitLow) {
servoh = servohLimitLow;
    }
}
    else if (avl<avr) {
servoh = ++servoh;
    if (servoh>servohLimitHigh) {
servoh = servohLimitHigh;
    }
}
    else if (avl = avr) {
// nothing
    }
horizontal.write(servoh);
}
delay(dtime);
}

```